

# IE-iMcV-E1-Mux/4(Enhanced)

Modular, Managed Four E1 Plus Data Extension Over Fiber

**The IE-iMcV-E1-Mux/4 Transports Four E1 Extensions and One RS-232 Serial Link Over a Fiber Optic Line With Optional 1+1 Protection and Full-Bandwidth 10/100 Ethernet Support.**

## Features and Benefits

- Four independent E1 ports on RJ-48 connectors with surge protection
- AIS generation on signal loss on all E1 and fiber interfaces
- AIS Detection
- Supports local and remote loopback functions
- Dual SFP fiber ports with 1+1 protection switching
- One optional full bandwidth, Ethernet 10/100BaseT port
- User defined bandwidth limiting on Ethernet port
- Auto Negotiation or forced modes on the Ethernet port
- E1 ports can be remotely disabled by user
- Supports Jumbo Ethernet frames to 1916
- Supports "Pause" Frames
- AutoCross MDI/MDI-X on Ethernet port
- Supports the Link Fault Pass-Through Function (LFPT)
- DDMI register retrieval supported on SFP port
- One end-to-end serial RS-232 port to 120 Kbps on an RJ-45 connector
- Both Host/Remote are managed from the Host unit
- Command Line Interface (CLI) management provided via one MiniJack RS-232 console port
- Remote Graphical User Interface (GUI) management through a managed iMediaChassis
- SNMP Alarm TRAP reporting in managed chassis, including Last Gasp
- Full LED diagnostics on front panel
- IE model supports extended temperature

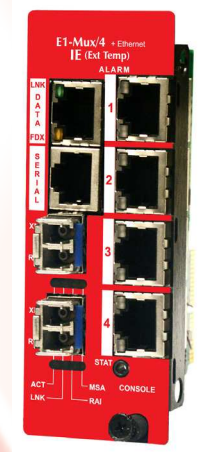

The IE-iMcV-E1-Mux/4 is a managed modular media converter, installed as a Host/Remote pair, that transports four independent E1 lines over a single or dual fiber optic line. The module is ideal for applications requiring TDM extension, such as remote office PABX connectivity, with support for a full bandwidth 10/100BaseT Ethernet connection over the same optical link.

The IE-iMcV-E1-Mux/4 allows for Bandwidth Limiting control in 32 Kbps increments up to 100 Mbps. It also detects Ethernet, AIS, E1 and fiber LOS events as well as degraded lines with full LED indications including a Remote Alarm Indicator (RAI) over the fiber link. E1 ports can also be enabled or disabled via the CLI, Telnet or SNMP management software, allowing the user to perform maintenance on a particular line without affecting others.

Fiber redundancy (1+1) on removable SFP modules offers the enhanced reliability of a protected fiber link while supporting the complete range of optical types and distances. The 1+1 protection system automatically switches to the best fiber line within 50 milliseconds, should one line become impaired or fail.

The module also features an independent serial link (RS-232) which is carried over the same fiber link(s), and can be used for transporting serial traffic from other equipment located at the remote point of presence (POP) back to the central office. This unit also supports an independent RS-232 console port for local monitoring and configuration of the unit by technical support personnel.

MEDIA CONVERSION

# Technical Specifications

- 2 x MSA compliant optical SFP slots
- 4 x E1 (RJ-48) copper ports
- Local RS-232 Console port
- RS-232 transparent to 120 Kbps
- IEEE 802.3x Flow Control
- IEEE 802.3i 10Base-T twisted pair
- IEEE 802.3u 100Base-TX twisted pair
- IEEE 802.3u 100Base-FX or SX fiber
- ITU G.775
- GR-820-CORE
- Supports over-sized packets up to 1916 bytes per packet
- Configurable as Host/ Remote pairs (DIP Switch selection)
- SNMP management via GUI-based iView<sup>2</sup> application software
- 10/100BaseT Full Bandwidth (144,800 fps/FDX)
- RoHS compliant
- Last Gasp Trap

## Connectors:

- Four E1 (RJ-48) copper ports
- Two SFP slots
- One RS-232 on MiniJack
- One 10/100BaseT on RJ-45
- One RS-232 on RJ-45

## Regulatory Approvals:

- IEEE-802.3u
- ITU G.775 (AIS, LOS)
- GR-820-CORE

## Dimensions:

Double-wide chassis module

## Shipping Weight:

1.1 lbs. (0.50 kg)

## Operating Temp:

-40°F to 158°F (-40°C to +70°C)  
5% to 95% (non-condensing),  
0 - 10,000 ft. altitude

## Storage Temp:

-40°F to 158°F (-40°C to +70°C)  
5 to 95% (non-condensing)

## Power Consumption (Typical):

0.96A @ +5 VDC

# Fiber Optics Specifications

The unit supports any MSA compliant SFP with a 155 Mbps bandwidth rating. DDMI capabilities are supported through the iView<sup>2</sup> management software when the unit is installed in a managed chassis. IMC Networks provides a complete range of SFP units in both Single and Dual fiber versions with a full range of wavelengths and distance ratings. For complete power budgets and information on calculating specific distances, visit [www.imcnetworks.com/go/fcs](http://www.imcnetworks.com/go/fcs) or contact IMC Networks Fiber Consulting Services at 949-465-3000 for a free consultation.

# Ordering Information

PART NUMBER	DESCRIPTION	DISTANCE
<b>IE-iMcV-E1-Mux/4</b>		
857-18111	IE-iMcV-E1-Mux/4+Ethernet, 2 x SFP (requires one or two SFP/155 Modules) <sup>§</sup>	2 km to 80 km
<b>IE-iMcV-E1-Mux/4 Accessories</b>		
825-39951	Serial Cable, MiniJack to DB9 (female)	

<sup>§</sup> SFP modules are sold separately. For more information on IMC Networks' SFPs, go to: [www.imcnetworks.com/Products/product.cfm?family=32](http://www.imcnetworks.com/Products/product.cfm?family=32)

# Application Example

In a typical application, a Customer PABX is provided with up to four E1 lines from the Public Switch Telephone Network (PSTN) over a protected optical link. In addition, the customer location can receive a full bandwidth, 100BaseT Ethernet connection to the Internet from the local Internet Service Provider (ISP) over the same, protected, optical link. Operation Administration and Management (OAM) functions for the link are provided from the Host location through either a "Console" RS-232 connection on the Host unit or a SNMP connection through the management interface at the Host chassis. In this example, the RS-232 "Console" port of the remote PABX is also carried back to the Host location for remote management of the customer located PABX, using the end-to-end serial RS-232 port on the iMcV-E1-Mux/4.

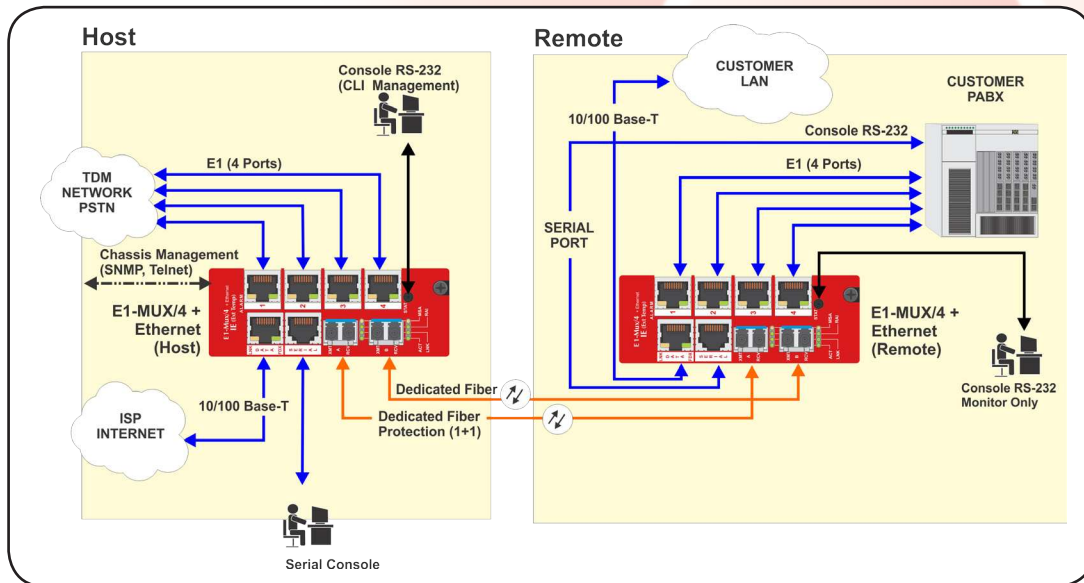

**IMC Networks**  
Headquarters  
19772 Pauling  
Foothill Ranch, CA 92610  
TEL: 949-465-3000  
FAX: 949-465-3020

**IMC Networks**  
Europe  
Herseltsesteenweg 268  
B-3200 Aarschot, Belgium  
TEL: +32-16-550880  
FAX: +32-16-550888  
eurosales@imcnetworks.com

**IMC Networks**  
Eastern US/Latin America  
28050 U.S. Hwy. 19 North, Suite 306  
Clearwater, FL 33761  
TEL: 727-797-0300  
FAX: 727-797-0331  
latinsales@imcnetworks.com

**IMC Networks**  
Fiber Consulting Services  
For information call:  
TEL: 949-465-3000  
1-800-624-1070 (US/CAN)  
+32-16-550880 (Europe)  
fcs@imcnetworks.com

Copyright © 2011 IMC Networks. All rights reserved. The information in this document is subject to change without notice. IMC Networks assumes no responsibility for any errors that may appear in this document. Specific product names may be trademarks or registered trademarks and are the property of their respective companies.