



Model 422PP9R Port-Powered RS-232 to RS-422 Converter CE

The 422PP9R is a port-powered, two-channel RS-232 to RS-422 converter. It converts TD and RD RS-232 lines to balanced RS-422 signals. The unit is powered from the RS-232 handshake lines DTR and RTS. Only one of these lines must be present, and the unit will work regardless of whether the lines are high or low. Both the RS-422 driver and receiver are enabled at all times.

To satisfy the requirements of some software, the RS-232 handshake lines are looped back (tied together). RTS is connected to CTS, and DTR is connected to DCD and DSR.

Connections

The 422PP9R is configured to transmit both directions between an RS-232 and RS-422 system. The RS-232 side is pinned out to connect directly into the COM port on your computer or any other DTE device (Table 1). The RS-422 side of the converter is pinned out as described in Table 2. When connecting to a RS-422 system, the 422PP9R **must** be connected with the proper polarity as shown in Figure 1. When no data is being sent the RS-232 line is negative and the RS-422 line TD(A) is negative with respect to TD(B).

Table 1 - RS-232 Pin Out

Signal	DB9 Female Pin #
TD	3
RD	2
RTS	7
CTS	8
DTR	4
DSR	6
DCD	1
GND	5

Table 2 - RS-422 Pin Out

Signal	DB9 Female Pin #
TD A (-)	8
TD B (+)	3
RD A (-)	2
RD B (+)	7
GND	4, 6

Figure 1 - Connection to an RS-422 System

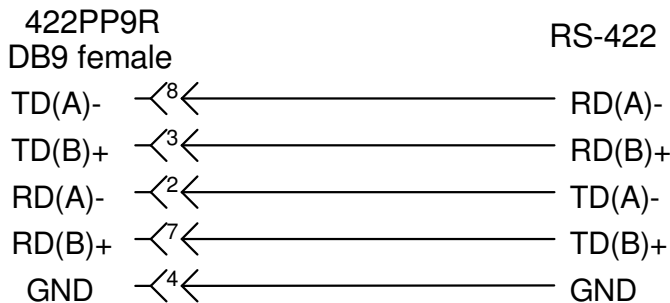

Biassing Resistors

The biasing resistors for the RS-422/RS-485 receiver are 4.7k Ohm resistors. These resistors are labeled R1 and R2 (See Figure 2). Refer to B&B Electronics RS-422/485 Application Note for further information on biasing.

Figure 2

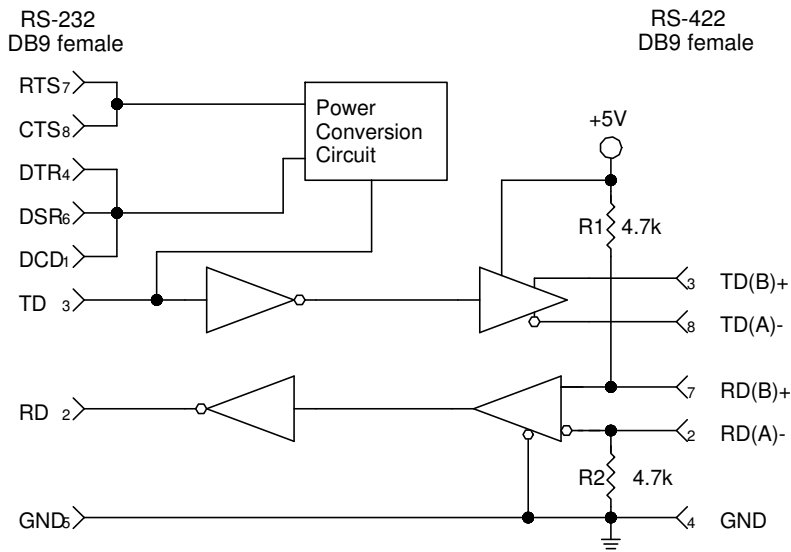

Specifications

- Communication: RS-422
- Data Rate: 115.2 kbps max.
- Power: Port-Powered from handshake lines on the RS-232 side.
- Dimensions: 6.1 x 3.3 x 1.7 cm (2.4 x 1.3 x 0.66 in)
- Temperature Rating: 0 to 70 °C

NOTE: When using an external supply, the supply should be connected only to specifically labeled power inputs (power jack, terminal block, etc.). Connecting an external power supply to the handshake lines may damage the unit. Contact technical support for more information on connecting an external power supply to the handshake lines.

DECLARATION OF CONFORMITY	
Manufacturer's Name:	B&B Electronics Manufacturing Company
Manufacturer's Address:	P.O. Box 1040 707 Dayton Road Ottawa, IL 61350 USA
Model Numbers:	422PP9R
Description:	9-Pin Port-Powered RS-422 Converter
Type:	Light industrial ITE equipment
Application of Council Directive:	89/336/EEC
Standards:	EN 55022 EN 61000-6-1 EN 61000 (-4-2, -4-3, -4-4, -4-5, -4-6, -4-8, -4-11)
 Robert M. Paratore, Director of Engineering	
