



Model 422CEC RS-232 to RS-422 Converter

This RS-232 to RS-422 converter converts unbalanced RS-232 signals to balanced RS-422 signals. The RS-422 Standard uses a balanced voltage digital interface to allow communications of 90K bits per second on cable lengths of 4000 feet. If this baud rate is exceeded the line length will decrease accordingly. Ten receivers can be connected to any one driver for use in multidrop systems.

Interconnection of the converter with another RS-422 device:

1. The polarity of the two RS-422 lines must be correct. With no data being sent, the RS-232 line should be negative and the RS-422 "A" terminal should be negative with respect to the "B" terminal.
2. The wire recommended in the RS-422 Standard is number 24 AWG copper conductor, twisted-pair telephone cable with a shunt capacitance of 16pF per foot.
3. For long runs and/or high data rates it is recommended that the wires be terminated with a resistor at the receive end. The twisted pair usually used has an impedance of about 100 ohms, therefore a 100 ohm resistor is normally used for the termination. The RS-422 side of the converter requires more power as the transmission line is increased and as the termination resistor value is reduced, therefore it may be necessary to use a termination resistor that is larger than 100 Ohms.
4. The RS-422 driver has the ability to drive 10 RS-422 receivers connected in parallel. A system of multiple receivers may require some experimentation with resistors, line lengths, grounding, etc.
5. The RS-422 Standard recommends that Protective Ground (pin 1) be connected to a good "green wire" ground. This may be already connected in your RS-232 equipment. Protective Ground and Signal Ground should be connected through to each end of the system and be connected to each other using a 100 ohm 1/2 watt resistor at one end only. If a shielded twisted pair is used the shield should be connected to Protective Ground.
6. Figure 1 shows the interconnection of two (2) 422CEC converters. This allows you to extend your RS-232 line up to 4000 feet. If you do not require all the handshake lines you may leave these disconnected.

Specifications

Data Rate: Up to 115.2K baud
 Connectors: RS-232: DB-25 female (DCE device)
 RS-422: DB-25 male (EIA-530 pin outs)
 Signals: Converts 8 channels of RS-232 to RS-422
 Power Requirement: 10 - 26 VDC @ 110 mA unloaded (422PS3)
 Additional current for external loading.

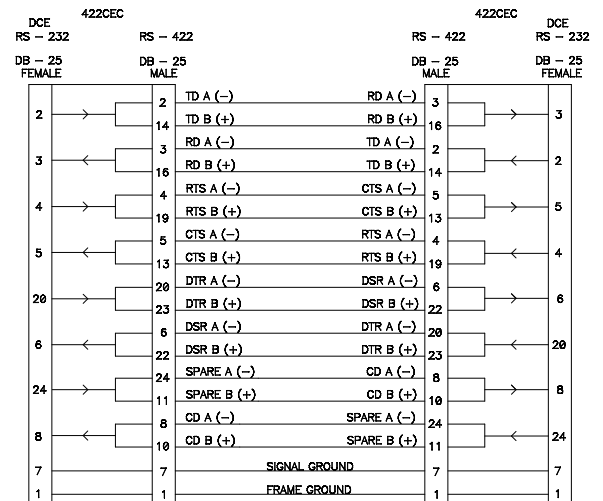

CABLE CAN BE UP TO 4000 FEET
SHELDIED TWISTED PAIR

DECLARATION OF CONFORMITY

Manufacturer's Name: B&B Electronics Manufacturing Company
 Manufacturer's Address: P.O. Box 1040
 707 Dayton Road
 Ottawa, IL 61350 USA
 Model Numbers: 422CEC
 Description: RS-232 to RS-422 Converter
 Type: Light industrial ITE equipment
 Application of Council Directive: 89/336/EEC
 Standards: EN 55022
 EN 61000-6-1
 EN 61000 (-4-2, -4-3, -4-4, -4-5, -4-6, -4-8, -4-11)

Robert M. Paratore, Director of Engineering





RS - 232

DB25S FEMALE CONNECTOR

1 FRAME GND

RS - 422

DB25P MALE CONNECTOR

1 FRAME GND

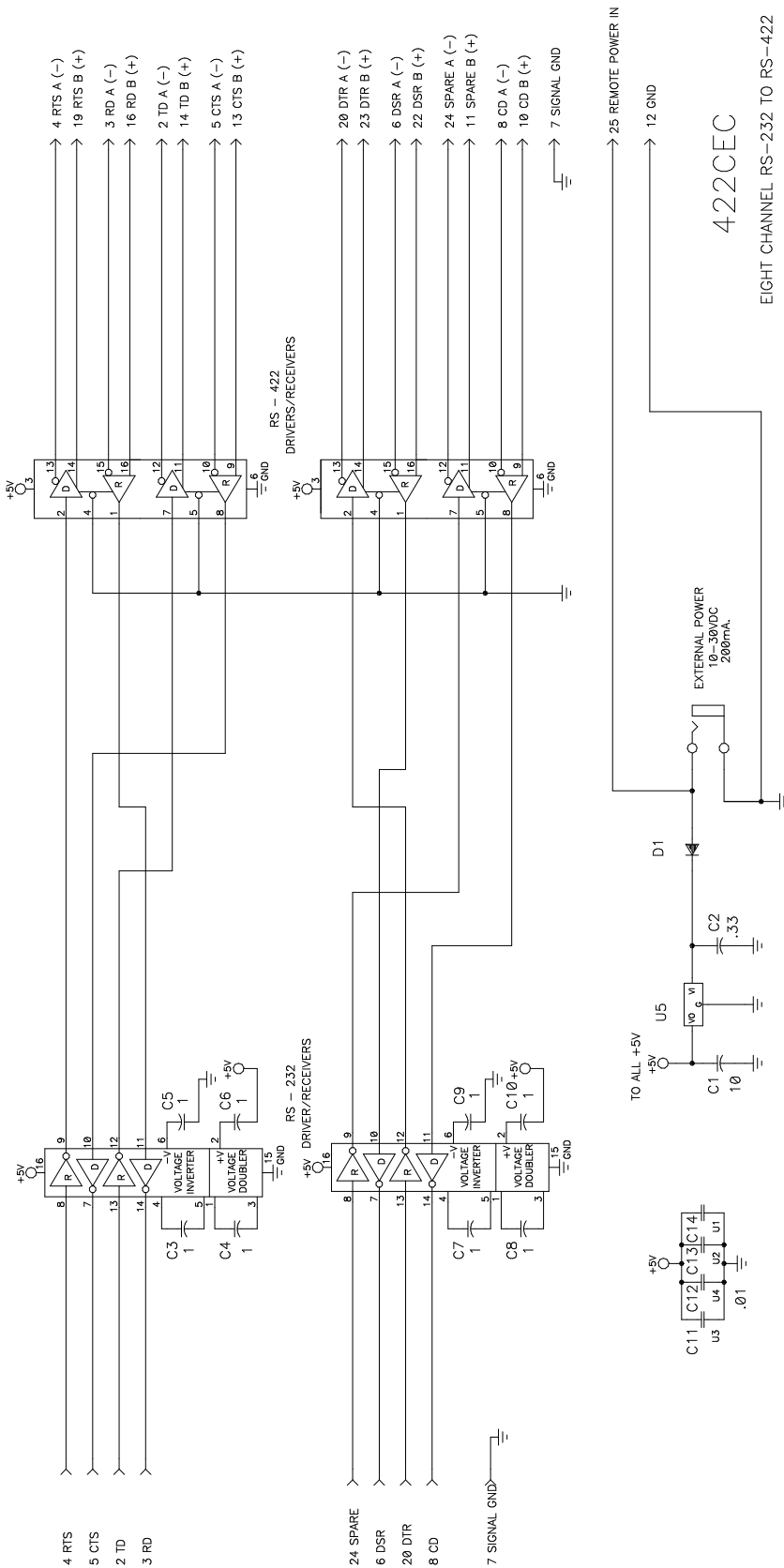

422CEC

EIGHT CHANNEL RS-232 TO RS-422 CONVERTER (SMT VERSION)