

TOLERANCE UNLESS OTHERWISE SPECIFIED IN MM:
 0 ±0.50
 0.0 ±0.38
 0.00 ±0.25
 0.000 ±0.10

THIS IS A C.A.D. GENERATED DRAWING
 DO NOT MAKE MANUAL REVISIONS TO MASTER.

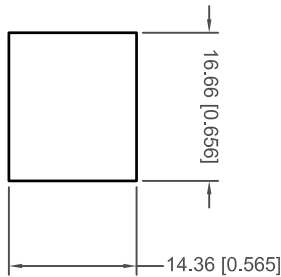

RECOMMENDED
 PANEL CUTOUT DIMENSION

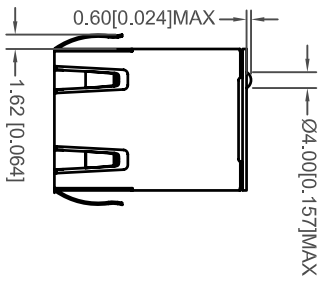
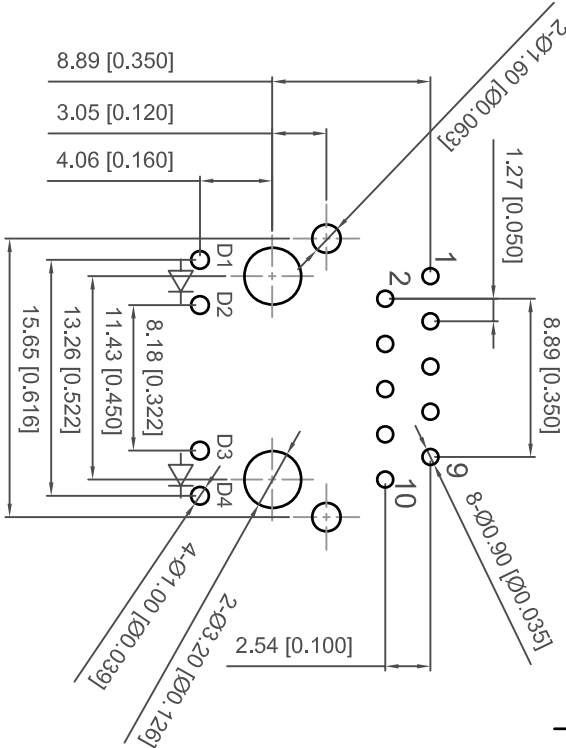
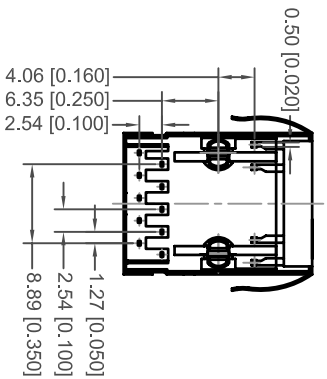
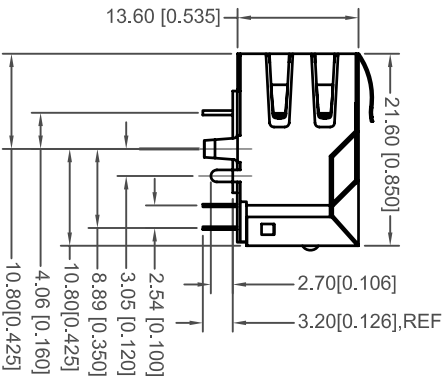
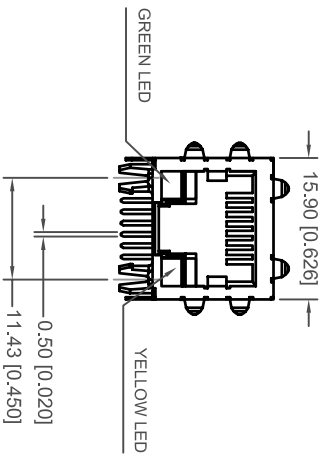

RECOMMENDED P.C.B. LAYOUT
 TOLERANCE: ±0.05 [±0.002]

- NOTES:
 1. MATERIALS:
 HOUSING: PBT WITH GLASS FIBER, UL94 V-0. COLOR: BLACK
 CONTACTS: 0.35MM PHOSPHOR BRONZE PLATED WITH
 GOLD PLATING AND TIN IN SOLDER AREA

PART NO	GOLD PLATING THICKNESS
A60-112-331P411	GOLD FLASH PLATING
A60-113-331P411	15 MICRO INCHES OF GOLD
A60-114-331P411	30 MICRO INCHES OF GOLD

- SHIELD: 0.20MM COPPER ALLOY WITH NICKEL PLATING
 2. OPERATING TEMPERATURE: 0°C TO +70°C
 3. MATE WITH MODULAR PLUG CONFORMING TO
 FCC PART 68, SUBPART F.
 4. DIMENSION: MM [INCHES]

RJ45 MAGNETIC JACK WITH LED, 10P, 8C
 SHIELDED/10/100/1000 Mbps FILTER

ACAD REFERENCE NO.: A60-112-331P411

DRAWN: R.STA.MONICA DATE: NOV.19/2010

CHECKED: DATE:

PART NUMBER

SEE NOTE

SHEET 1 OF 2

DRAWING NUMBER

A60-112-331P411

ISSUE

1



THIS SERIES FULLY CONFORMS TO THE
 EUROPEAN UNION DIRECTIVES 2002/95/EC
 AND 2002/96/EC FOR RoHS COMPLIANCY.



EDAC INC
 TORONTO, ONTARIO
 CANADA

YOUR CONNECTION TO QUALITY & SERVICE

ELECTRICAL CIRCUIT:

TOLERANCE UNLESS OTHERWISE SPECIFIED IN MM:

0	± 0.50	ANGLE	3°
0.0	± 0.38		
0.00	± 0.25		
0.000	± 0.10		

THIS IS A C.A.D. GENERATED DRAWING
DO NOT MAKE MANUAL REVISIONS TO MASTER.

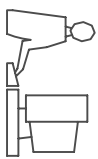

ISSUE NUMBER
ORIGINAL

CONNECTOR SOLDER SIDE

RJ45 CONTACT SIDE

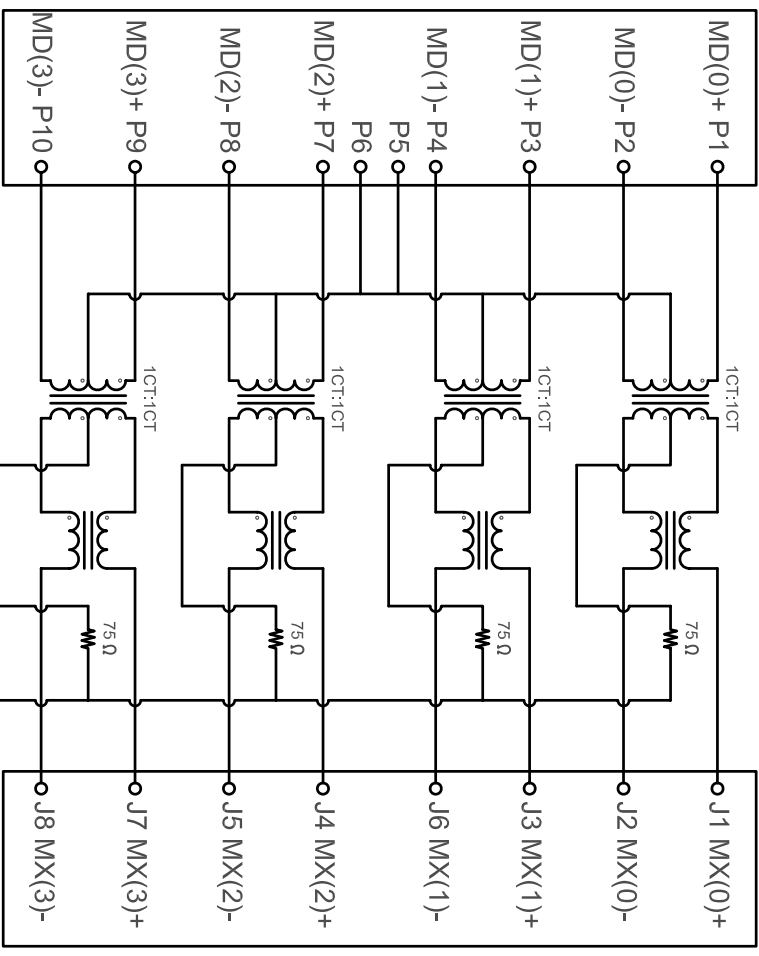

LED CIRCUIT:

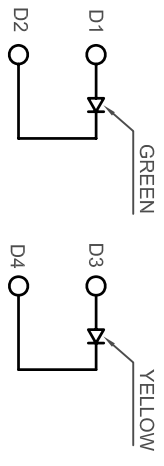

TEST NOTES:(25°±5°C)

- TR:(100KHz,0.1V): 100%
PINS:(P1,P2):(J1,J2)=1:1±3%;(P3,P4):(J3,J6)=1:1±3%
PINS:(P7,P8):(J4,J5)=1:1±3%;(P9,P10):(J7,J8)=1:1±3%
- LX:(100KHz,100mV,8mA,DC Bias) 100%
PINS:(P1,P2),(P3,P4),(P7,P8),(P9,P10)=350uH MINIMUM
- DCR: 100%
PINS:(J1,J2),(J3,J6),(J4,J5),(J7,J8)=1.2 MAXIMUM
- HIPOT: 100%
PINS:(P1,P2)TO(J1,J2),(P3,P4)TO(J3,J6)=1500VAC FOR 2 SECONDS
PINS:(P7,P8)TO(J4,J5),(P9,P10)TO(J7,J8)=1500VAC FOR 2 SECONDS
- INSERTION LOSS:
-1.0dB MAXIMUM AT 1MHZ TO 100MHZ;
- RETURN LOSS:
-20dB MINIMUM AT 1MHZ TO 30MHZ;
-15dB MINIMUM AT 30MHZ TO 60MHZ
-10dB MINIMUM AT 60MHZ TO 80MHZ
- CROSS TALK:
-30dB MINIMUM AT 1MHZ TO 100MHZ
-30dB MINIMUM AT COMMON MODE REJECTION:
- COMMON TO COMMON MODE REJECTION:
-30dB MINIMUM AT 1MHZ TO 100MHZ

Color	Lens Color	Vf(V) @20mA	Iv(mcd) @10mA	Viewing angle
		Min	Min	Typ
Yellow	Yellow Diffused	1.7	2.8	3.0
Green	Green Diffused	1.7	2.8	3.5
				6.0
				116

**RJ45 MAGNETIC JACK WITH LED, 10P, 8C
SHIELDED/10/100/1000 Mbps FILTER**

ACAD REFERENCE NO.: A60-112-331P411

DRAWN: R.STA.MONICA DATE: NOV.19/2010

CHECKED: DATE:

PART NUMBER

SEE NOTE

DRAWING NUMBER SHEET 2 OF 2

A60-112-331P411

ISSUE
1



THIS SERIES FULLY CONFORMS TO THE EUROPEAN UNION DIRECTIVES 2002/95/EC AND 2002/96/EC FOR RoHS COMPLIANCY.

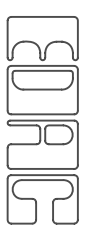

EDAC INC
TORONTO, ONTARIO
CANADA

YOUR CONNECTION TO QUALITY & SERVICE

THESE DRAWINGS AND SPECIFICATIONS ARE THE PROPERTY OF EDAC INC. AND SHALL NOT BE REPRODUCED OR COPIED OR USED AS THE BASIS FOR THE MANUFACTURE OR SALE OF APPARATUS WITHOUT WRITTEN PERMISSION.