

# YOUR CONNECTION TO QUALITY AND SERVICE

## EDAC - A WORLD-CLASS CONNECTOR COMPANY

Since its formation over 30-years ago, EDAC Inc. has grown to become one of the world's leading manufacturers of card-edge, rack-and-panel, D-Subminiature and specialty telecom connectors. Its strong and loyal customer base know EDAC's motto - **Your Connection to Quality and Service** - guarantees a comprehensive variety of custom connectors backed by superior customer service.

EDAC is not content to rest on its three-decade reputation for quality and service. It continually strives to improve its competitiveness, while performing to the best standards of the connector industry. The realization of the global economy and its industry-wide impact have changed the direction at EDAC. Its goals and objectives start with you: *the customer*. Its stated aim is to be the best connector company, offering superior world-class service.

EDAC is positioned to win on a global scale. Its three Customer Logistics Centres - in Toronto, London and Hong Kong - manage just-in-time inventories to respective markets. New design-to-volume programs include surface mount and pin-and-paste 'reflow' soldering connectors. There are 18 sales offices in the U.S., 12 in Europe, 11 in Canada and the rest of the world. Distribution requirements are served through over 100 stocking locations in the U.S., and in locations throughout Europe, including Germany, England, Italy, Switzerland, France and Spain.

While striving for new customers worldwide, EDAC remembers its established customers; to them, EDAC extends its sincerest thanks for the privilege of serving their past needs, and for being a part of their new and exciting plans for the future. EDAC's newer customers soon discover what its older customers rely upon: EDAC is their **Connection to Quality and Service**.

**CHECK OUT EDAC'S WEB SITE:  
A World-Class Connector Company  
On The Worldwide Web**



[www.edac.net](http://www.edac.net)

# YOUR CONNECTION TO QUALITY AND SERVICE

<b>621/622 SERIES</b> .....	<b>4</b>
<b>Plug and Receptacle, Right Angle, .318" (8.08mm) Footprint</b> .....	4, 5
<b>623/624 SERIES</b> .....	<b>6</b>
<b>Plug and Receptacle, Right Angle, .200" (5.08mm) Footprint</b> .....	6, 7
<b>625/626 SERIES</b> .....	<b>8</b>
<b>Plug and Receptacle, Right Angle, .590" (14.99mm) Footprint</b> .....	8, 9
<b>627/628 SERIES</b> .....	<b>10</b>
<b>Plug and Receptacle, Vertical, PCB Mount, METAL Body Configurations</b> .....	10, 11
<b>Plug and Receptacle, Vertical, PCB Mount, PLASTIC Body Configurations</b> .....	12, 13
<b>629/630 SERIES</b> .....	<b>14</b>
<b>Plug and Receptacle, Right Angle, .370" (9.44mm) Footprint</b> .....	14, 15
<b>632 SERIES</b> .....	<b>16</b>
<b>Receptacle, Right Angle, High-Density, .125" (3.175mm) Footprint</b> .....	16, 17
<b>633/634 SERIES</b> .....	<b>18</b>
<b>Plug and Receptacle, Right Angle, High-Density, .350" (8.89mm) Footprint</b> .....	18, 19
<b>637/638 SERIES</b> .....	<b>20</b>
<b>Plug and Receptacle, Vertical High-Density, PCB Mount, Metal Body</b> .....	20, 21
<b>661/662/663/664 SERIES</b> .....	<b>22</b>
<b>Plug and Receptacle Combination, Dual Port, Right Angle Connectors</b> .....	22, 23
<b>GROUNDING AND MOUNTING OPTIONS</b> .....	<b>24</b>
<b>Dual Port Connectors</b> .....	24
<b>Right Angle Connectors, All Series</b> .....	25
<b>Straight Connectors</b> .....	26
<b>HOLE PATTERN RECOMMENDED</b> .....	<b>27</b>
<b>Series 619, 620, 622, 627, 628, 629, 630</b> .....	27
<b>Series 625, 626</b> .....	28
<b>Series 633, 634</b> .....	29
<b>Series 632, 637, 638</b> .....	30
<b>ENGINEERING NOTES</b> .....	<b>31</b>
<b>Insulation/Contact/Metal Hardware Material, Contact Finish, ULA</b> .....	31
<b>Special Variation Connectors, Environmental Responsibility, General Notes</b> .....	32
<b>Plating Codes, Thermal Properties of Insulator Molding Materials</b> .....	33

# 621/622 SERIES

Plug and Receptacle, Right Angle, .318" (8.08mm) Footprint



## FEATURES

- Two contact rows with .318" (8.08mm) footprint right-angle bend.
- .109" (2.77mm) contact spacing x .112" (2.82mm) row spacing.
- Plug and receptacle in 9-, 15-, 25- or 37-pin contact sizes.
- Pin and socket contact mating design with PC tail termination.
- Metal shell provides EMI/RFI shielding. Plug shell indents provide grounding and additional mating retention.
- Grounding features include top or bottom ground plates and four-prong boardlock for superior retention to PC board.
- Mounting options for panel mount or connector mating include through-hole, threaded inserts and threaded standoffs.
- D-shaped connector mating outline provides polarization.
- Design based on requirements of MIL-C-24308, EIA RS-232 and RS-449.

## SPECIFICATIONS

- Insulator Material: Thermoplastic polyester, UL 94V-0; chemical resistant; colour - black.
- Ferrite Specifications: Attenuation - 20dB MIN @ 30Mhz, 30dB MIN @ 50MHz, and 50dB MIN @ 100Mhz.
- Contact Material: Plug contacts - brass; receptacle contacts - phosphor bronze.
- Contact Plating: Gold (see *Ordering Code*) over nickel for the mating area; tin/lead plating on contact tails.
- Shell Material: Nickel-plated steel.
- Current Rating: 5 amperes.
- Contact Resistance: 10 milliohms maximum.
- Dielectric Withstanding Voltage: 1000 V AC rms @ sea level.
- Insulation Resistance: 5000 megohms minimum.
- Operating Temperature: -55° to +105° C
- Engagement & Separation Force: 1 to 10 oz. (0.28 to 2.78 N) per contact position.

## 621/622 SERIES ORDERING CODE

Example:

**621-025-560-013**

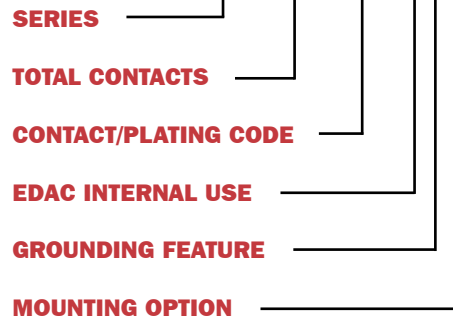

### SERIES

**621** .....Plug  
**622** .....Receptacle

### TOTAL CONTACTS

**009, 015, 025, 037** .....50 (machined pin only)

### CONTACT/PLATING CODE

**260** .....Gold Flash (Class 3)  
**560** .....10µ" (0.25µm) (Class 2)  
**660** .....30µ" (0.76µm) (Class 1)  
**668** .....Ferrite Filter

### EDAC INTERNAL USE

**0** .....Indicates generic internal use code

### GROUNDING FEATURE

**1** ..... .120" (3.05mm) dia. through hole top ground  
**3** ..Two-prong boardlocks for .120" (3.05mm) dia. PCB hole  
**4** ..Four-prong boardlocks for .120" (3.05mm) dia. PCB hole

### MOUNTING OPTION

**0** .....#4-40 UNC fixed standoff  
**1** ..... .125" (3.18mm) dia. through-hole  
**2** .....#4-40 UNC threaded insert  
**3** .....#4-40 UNC threaded standoff  
**5** .....#4-40 UNC threaded standoff & lock washer

# 621/622 SERIES

## Plug and Receptacle, Right Angle, .318" (8.08mm) Footprint

### PLUG 621 SERIES

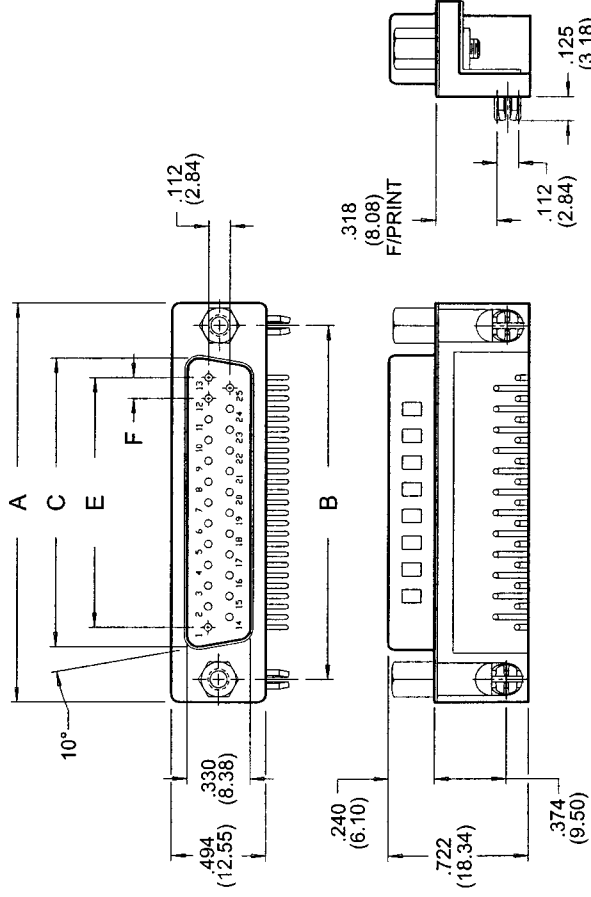

### RECEPTACLE 622 SERIES

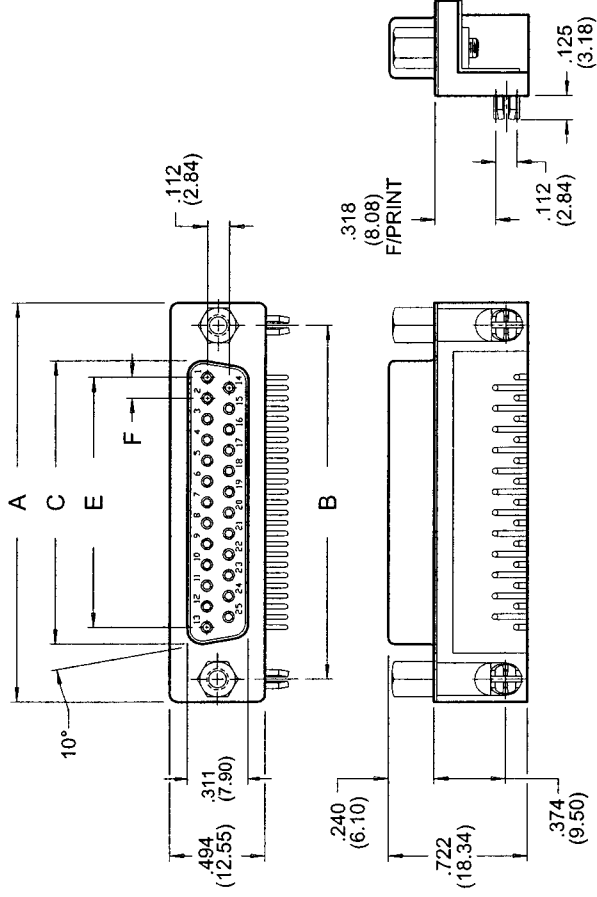

NUMBER OF CONTACTS	A		B		C		PLUG		RECEPTACLE		E		F	
	Inch	(mm)	Inch	(mm)	Inch	(mm)	Inch	(mm)	Inch	(mm)	Inch	(mm)	Inch	(mm)
9	1.214	(30.84)	.984	(24.99)	.667	(16.92)	.640	(16.26)	.432	(10.97)	.108	(2.74)	.108	(2.74)
15	1.545	(39.24)	1.312	(33.32)	.994	(25.25)	.967	(24.56)	.756	(19.20)	.108	(2.74)	.108	(2.74)
25	2.088	(53.04)	1.852	(47.04)	1.534	(38.96)	1.508	(38.30)	1.304	(33.12)	.109	(2.76)	.109	(2.76)
37	2.730	(69.34)	2.500	(63.50)	2.182	(53.08)	2.156	(54.76)	1.956	(49.68)	.109	(2.76)	.109	(2.76)

# 623/624 SERIES

Plug and Receptacle, Right Angle, .200" (5.08mm) Footprint



## 623/624 SERIES ORDERING CODE

Example:

**624-025-261-033**

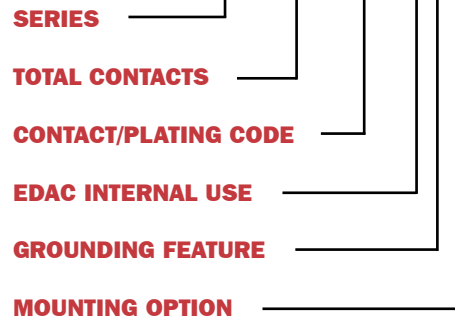

## FEATURES

- Two contact rows with .200" (5.08mm) footprint right angle bend.
- .109" (2.77mm) contact spacing x .112" (2.82mm) row spacing.
- Pin and socket contact mating design with PC tail termination.
- Metal shell provides EMI/RFI shielding. Plug shell indents provide grounding and additional mating retention.
- Grounding features include two-prong boardlock for exceptional retention to PC board.
- Mounting options for panel mount or connector mating include through-hole, threaded inserts and threaded standoffs.
- D-shaped connector mating outline provides polarization.
- Design based on requirements of MIL-C-24308, EIA RS-232 and RS-449.

## SPECIFICATIONS

- Insulator Material: Thermoplastic polyester, UL 94V-0; chemical resistant; colour - black.
- Contact Material: Plug contacts - brass; receptacle contacts - phosphor bronze.
- Contact Plating: Gold (see *Ordering Code*) over nickel for the mating area, tin-lead plating on contact tails.
- Shell Material: Nickel-plated steel. (tin/lead optional)
- Current Rating: 5 amperes.
- Contact Resistance: 10 milliohms maximum.
- Dielectric Withstanding Voltage: 1000V AC rms at sea level.
- Insulation Resistance: 5000 megohms minimum.
- Operating Temperature: -55° to +105° C.
- Engagement and Separation Force: 1 to 10 oz. (0.28 to 2.78 N) per contact position.

### SERIES

**623** ..... ( 9-pin only) Plug  
**624** ..... Receptacle

### TOTAL CONTACTS

**009, 015, 025**

### CONTACT/PLATING CODE

**261** ..... Gold Flash (Class 3)  
**361** ..... 15µ" (0.38µm) (Class 2)  
**661** ..... 30µ" (0.76µm) (Class 1)

### EDAC INTERNAL USE

**0** ..... Indicates generic internal use code

### GROUNDING FEATURE

**3** ..... Two-prong boardlocks for .120" (3.05mm) dia. hole

### MOUNTING OPTION

**1** ..... 125" (3.18mm) dia. through-hole  
**2** ..... #4-40 UNC threaded insert  
**3** ..... #4-40 UNC hex standoff

# 623/624 SERIES

## Plug and Receptacle, Right Angle, .200" (5.08mm) Footprint

### PLUG 623 SERIES

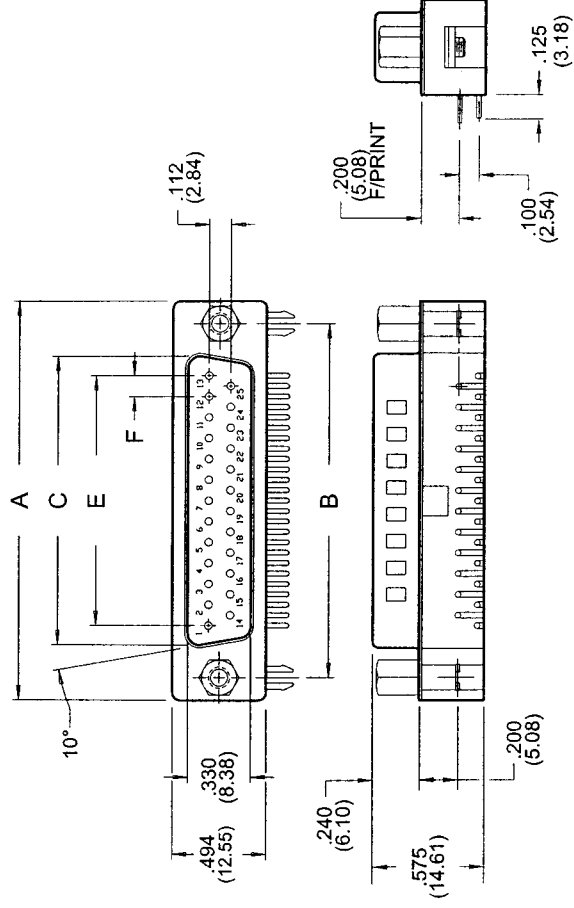

### RECEPTACLE 624 SERIES

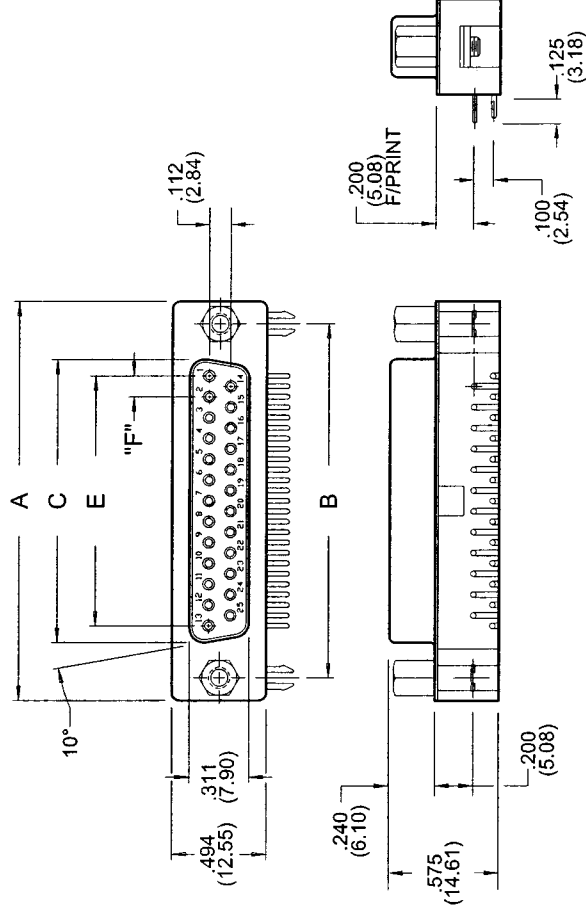

NUMBER OF CONTACTS	A		B		C PLUG		C RECEPTACLE		E		F	
	Inch	(mm)	Inch	(mm)	Inch	(mm)	Inch	(mm)	Inch	(mm)	Inch	(mm)
9	1.214	(30.84)	.984	(24.99)	.667	(16.92)	.640	(16.26)	.432	(10.97)	.108	(2.74)
15	1.545	(39.24)	1.312	(33.32)	.994	(25.25)	.967	(24.56)	.756	(19.20)	.108	(2.74)
25	2.088	(53.04)	1.852	(47.04)	1.534	(38.96)	1.508	(38.30)	1.304	(33.12)	.109	(2.76)

# 625/626 SERIES



## FEATURES

- Two contact rows with .590" (14.99mm) footprint right angle bend.
- .109" (2.77mm) contact spacing x .112" (2.82mm) row spacing.
- Plug and receptacle in 9-, 15-, 25- or 37-pin contact sizes.
- Pin and socket contact mating design with PC tail termination.
- Metal shell provides EMI/RFI shielding. Plug shell indents provide grounding and additional mating retention.
- Grounding features include top and bottom ground plates and four-prong boardlock for superior retention to PC board.
- Mounting options for panel mount or connector mating include through-hole, threaded inserts and threaded standoffs.
- D-shaped connector mating outline provides polarization design based on requirements of MIL-C-24308, EIA RS-232 and RS-449.

## SPECIFICATIONS

- Insulator Material: Thermoplastic polyester, UL 94V-0; chemical resistant; colour - black.
- Contact Material: Plug contacts - brass; receptacle contacts - phosphor bronze.
- Contact Plating: Gold (see *Ordering Code*) over nickel for the mating area, tin/lead plating on contact tails.
- Shell Material: Nickel-plated steel.
- Current Rating: 5 amperes.
- Contact Resistance: 10 milliohms maximum.
- Dielectric Withstanding Voltage: 1000V AC rms at sea level.
- Insulation Resistance: 5000 megohms minimum.
- Operating Temperature: -55° to +105° C.
- Engagement and Separation Force: 1 to 10 oz. (0.28 to 2.78 N) per contact position.

## 625/626 SERIES ORDERING CODE

Example:

**626-037-562-043**

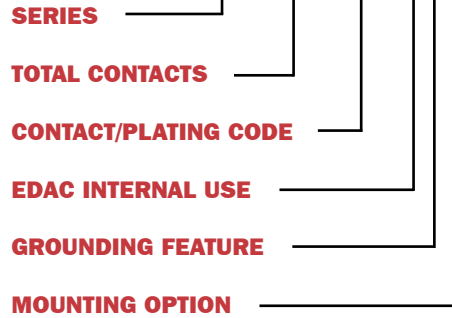

<b>SERIES</b>	
<b>625</b> .....	Plug
<b>626</b> .....	Receptacle

<b>TOTAL CONTACTS</b>	
<b>009, 015, 025, 037</b>	

<b>CONTACT/PLATING CODE</b>	
Right angle .590" (14.99mm) footprint	
<b>262</b> .....	Gold Flash (Class 3)
<b>562</b> .....	10µ" (0.25µm) (Class 2)
<b>662</b> .....	30µ" (0.76µm) (Class 1)

<b>EDAC INTERNAL USE</b>	
<b>0</b> .....	Indicates generic internal use code

<b>GROUNDING FEATURE</b>	
<b>1</b> .....	.120" (3.05mm) dia. through-hole top ground
<b>2</b> .....	.120" (3.05mm) dia. through-hole bottom ground
<b>3</b> .....	Two-prong boardlock for .120" (3.05mm) dia. PCB hole
<b>4</b> .....	Four-prong boardlock for .120" (3.05mm) dia. PCB hole

<b>MOUNTING OPTION</b>	
<b>0</b> .....	Fixed hex standoff
<b>1</b> .....	.125" (3.18mm) dia. through-hole
<b>2</b> .....	#4-40 UNC threaded insert
<b>3</b> .....	#4-40 UNC threaded standoff

# 625/626 SERIES

## Plug and Receptacle, Right Angle, .590" (14.99mm) Footprint

### PLUG 625 SERIES

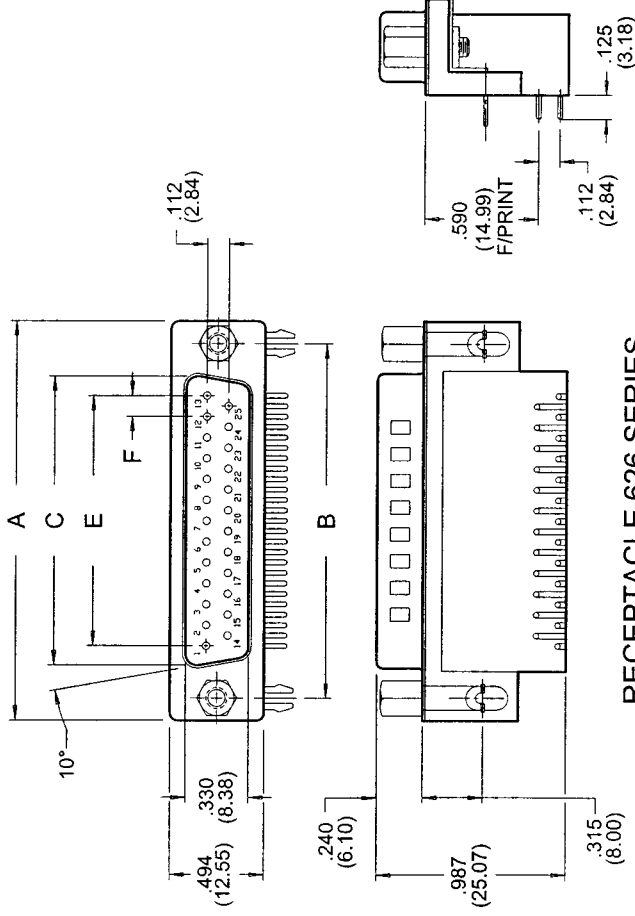

### RECEPTACLE 626 SERIES

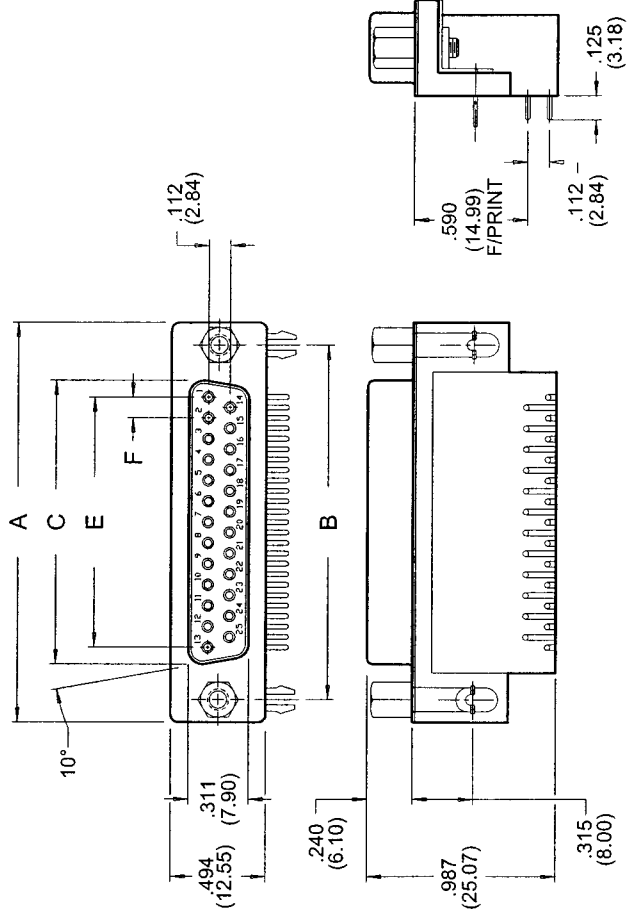

NUMBER OF CONTACTS	A		B		C		PLUG		RECEPTACLE		E		F	
	Inch	(mm)	Inch	(mm)	Inch	(mm)	Inch	(mm)	Inch	(mm)	Inch	(mm)	Inch	(mm)
9	1.214	(30.84)	.984	(24.99)	.667	(16.92)	.640	(16.26)	.432	(10.97)	.108	(2.74)	.108	(2.74)
15	1.545	(39.24)	1.312	(33.32)	.994	(25.25)	.967	(24.56)	.756	(19.20)	.108	(2.74)	.108	(2.74)
25	2.088	(53.04)	1.852	(47.04)	1.534	(38.96)	1.508	(38.30)	1.304	(33.12)	.109	(2.76)	.109	(2.76)
37	2.730	(69.34)	2.500	(63.50)	2.182	(53.08)	2.156	(54.76)	1.956	(49.68)	.109	(2.76)	.109	(2.76)



# 627/628 SERIES



## 627/628 SERIES ORDERING CODE

**Example:**

627-025-220-047

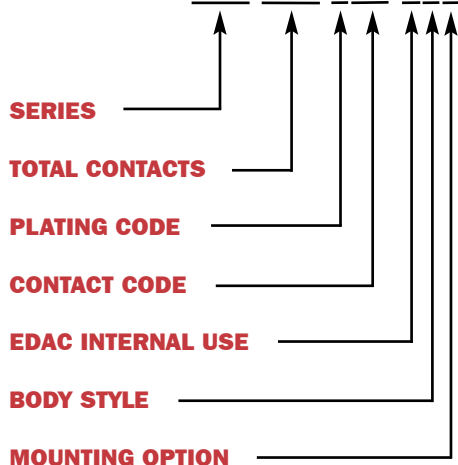

### FEATURES

- Both low and high profiles available.
- .109" (2.77mm) contact spacing x .112" (2.82mm) row spacing.
- Plug and receptacle in 9-, 15-, 25-, 37- and 50-pin contact sizes.
- Pin and socket contact mating design with PC tail termination.
- Metal shell provides EMI/RFI shielding. Plug shell indents provide grounding and additional mating retention.
- Grounding features include two-prong boardlock for exceptional retention to PC board.
- Mounting options for panel mount or connector mating include through-hole, threaded inserts and threaded standoffs.
- D-shaped connector mating outline provides polarization design based on requirements of MIL-C-24308, EIA RS-232 and RS-449.

### SPECIFICATIONS

- Insulator Material: Thermoplastic polyester, UL 94V-0; chemical resistant; colour - black.
- Ferrite Specifications: Attenuation - 20dB MIN @ 30Mhz, 30dB MIN @ 50Mhz and 50db MIN @ 100Mhz.
- Contact Material: Plug contacts - brass; receptacle contacts - phosphor bronze.
- Contact Plating: Gold (see *Ordering Code*) over nickel for the mating area, tin/lead plating on contact tails.
- Shell Material: Nickel-plated steel (tin/lead optional)
- Current Rating: 5 amperes.
- Contact Resistance: 10 milliohms maximum.
- Dielectric Withstanding Voltage: 1000V AC rms at sea level.
- Insulation Resistance: 5000 megohms minimum.
- Operating Temperature: -55° to +105° C.
- Engagement and Separation Force: 1 to 10 oz. (0.28 to 2.78 N) per contact position.

#### SERIES

**627** .....Plug  
**628**.....Receptacle

#### TOTAL CONTACTS

**009, 015, 025, 037, 050**

#### PLATING CODE

**2** .....Gold Flash (Class 3)  
**3** .....15µ" (0.38µm) (Class 2)  
**6** .....30µ" (0.76µm) (Class 1)

#### CONTACT CODE

**20** .....PC tail .125" (3.18mm)  
**21** .....PC tail .165" (4.18mm)  
**22** .....Solder cup termination  
**28** .....Ferrite filter

#### EDAC INTERNAL USE

**0** .....Indicates generic internal use code

#### BODY STYLE

**4** .....Metal covered .276" (7.00mm) low profile  
**5** .....Metal covered .472" (12.00mm) high profile  
**6** .....Metal covered machined contacts low profile

#### MOUNTING OPTION

**1** ..... .125" (3.18mm) dia. through-hole  
**2** .....#4-40 UNC threaded inserts  
**3** .....#4-40 UNC threaded standoffs  
**6** .....#4-40 UNC threaded insert with boardlocks  
**7** .....#4-40 UNC threaded standoff with boardlocks  
**8** .....#4-40 UNC threaded fixed standoffs

# 627/628 SERIES

## Plug and Receptacle, Vertical, PCB Mount, METAL Body Configurations

### PLUG 627 SERIES

#### LOW PROFILE

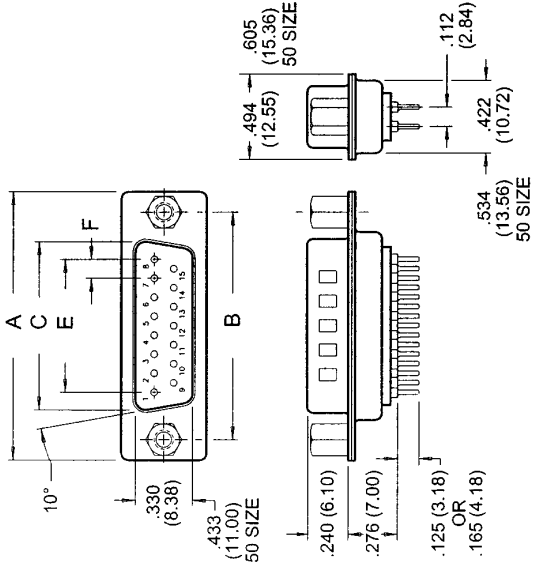

#### HIGH PROFILE

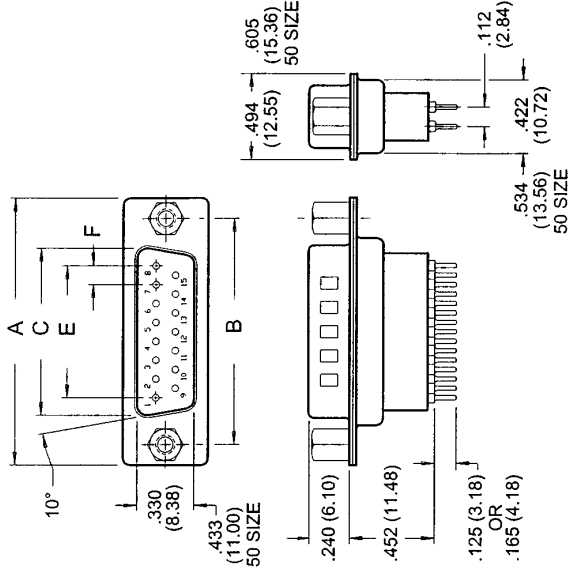

### RECEPTACLE 628 SERIES

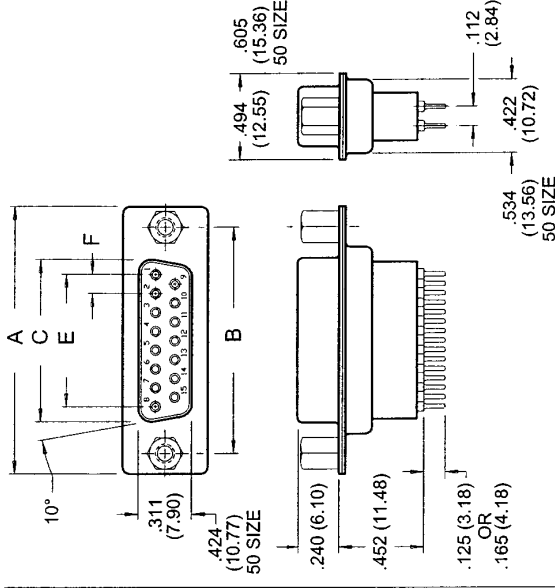
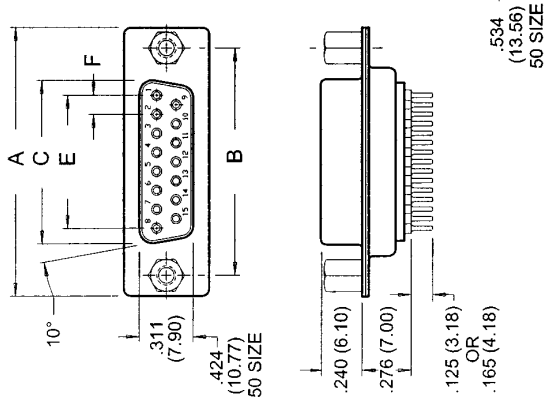

NUMBER OF CONTACTS	A		B		C		RECEPTACLE		F			
	Inch	(mm)	Inch	(mm)	Inch	(mm)	Inch	(mm)	Inch	(mm)		
9	1.214	(30.84)	.984	(24.99)	.667	(16.92)	.640	(16.26)	.432	(10.97)	.108	(2.74)
15	1.545	(39.24)	1.312	(33.32)	.994	(25.25)	.967	(24.56)	.756	(19.20)	.108	(2.74)
25	2.088	(53.04)	1.852	(47.04)	1.534	(38.96)	1.508	(38.30)	1.304	(33.12)	.109	(2.76)
37	2.730	(69.34)	2.500	(63.50)	2.182	(53.08)	2.156	(54.76)	1.956	(49.68)	.109	(2.76)
50	2.640	(67.05)	2.406	(61.11)	2.080	(52.83)	2.054	(52.17)	1.740	(44.20)	.109	(2.76)



# 627/628 SERIES

## 627/628 SERIES ORDERING CODE

**Example:**

627-025-220-017

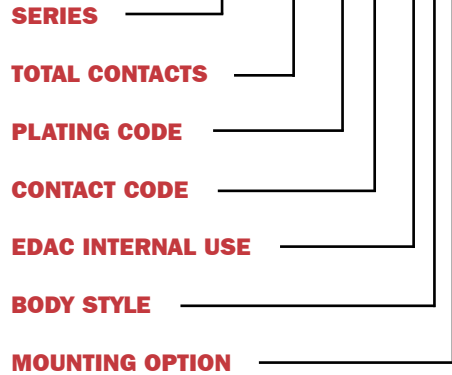

## FEATURES

- Low profile available.
- .109" (2.77mm) contact spacing x .112" (2.82mm) row spacing.
- Plug and receptacle in 9-, 15-, 25-, 37-pin contact sizes.
- Pin and socket contact mating design with PC tail termination.
- Metal shell provides EMI/RFI shielding. Plug shell indents provide grounding and additional mating retention.
- Grounding features include two-prong boardlock for exceptional retention to PC board.
- Mounting options for panel mount or connector mating include through-hole, threaded inserts and threaded standoffs.
- D-shaped connector mating outline provides polarization design based on requirements of MIL-C-24308, EIA RS-232 and RS-449.

## SPECIFICATIONS

- Insulator Material: Thermoplastic polyester, UL 94V-0; chemical resistant; colour - black.
- Contact Material: Plug contacts - brass; receptacle contacts - phosphor bronze.
- Contact Plating: Gold (see *Ordering Code*) over nickel for the mating area, tin/lead plating on contact tails.
- Shell Material: Nickel-plated steel (tin/lead optional)
- Current Rating: 5 amperes.
- Contact Resistance: 10 milliohms maximum.
- Dielectric Withstanding Voltage: 1000V AC rms at sea level.
- Insulation Resistance: 5000 megohms minimum.
- Operating Temperature: -55° to +105° C.
- Engagement and Separation Force: 1 to 10 oz. (0.28 to 2.78 N) per contact position.

### SERIES

**627** .....Plug  
**628**.....Receptacle

### TOTAL CONTACTS

**009, 015, 025, 037**

### PLATING CODE

**2** .....Gold Flash (Class 3)  
**3** .....15µ" (0.38µm) (Class 2)  
**6** .....30µ" (0.76µm) (Class 1)

### CONTACT CODE

**20** .....PC tail .140" (3.18mm)  
**21** .....PC tail .165" (4.18mm)

### EDAC INTERNAL USE

**0** .....Indicates generic internal use code

### BODY STYLE

**1** .....Plastic .237" (6.02mm) low profile, polyester

### MOUNTING OPTION

**1** ..... .125" (3.18mm) dia. through-hole  
**2** .....#4-40 UNC threaded inserts  
**3** .....#4-40 UNC threaded standoffs  
**4** .....#4-40 UNC threaded insert with dip solder prongs  
**5** .....#4-40 UNC threaded standoff with dip solder prongs  
**6** .....#4-40 UNC threaded insert with boardlocks  
**7** .....#4-40 UNC threaded standoff with boardlocks

# 627/628 SERIES

## Plug and Receptacle, Vertical, PCB Mount, PLASTIC Body Configurations

### PLUG 627 SERIES

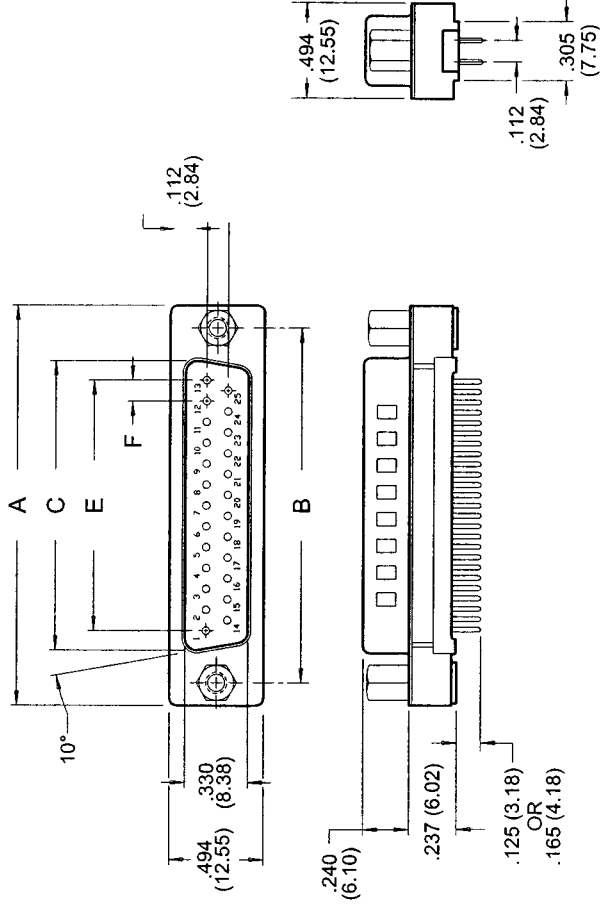

### RECEPTACLE 628 SERIES

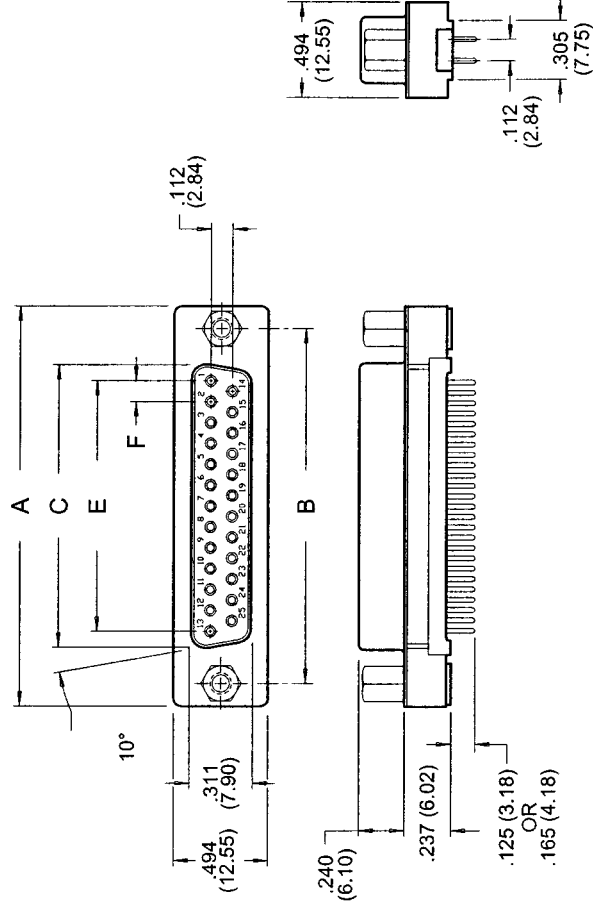

NUMBER OF CONTACTS	A		B		C PLUG		C RECEPTACLE		E		F	
	Inch	(mm)	Inch	(mm)	Inch	(mm)	Inch	(mm)	Inch	(mm)	Inch	(mm)
9	1.214	(30.84)	.984	(24.99)	.667	(16.92)	.640	(16.26)	.432	(10.97)	.108	(2.74)
15	1.545	(39.24)	1.312	(33.32)	.994	(25.25)	.967	(24.56)	.756	(19.20)	.108	(2.74)
25	2.088	(53.04)	1.852	(47.04)	1.534	(38.96)	1.508	(38.30)	1.304	(33.12)	.109	(2.76)
37	2.730	(69.34)	2.500	(63.50)	2.182	(53.08)	2.156	(54.76)	1.956	(49.68)	.109	(2.76)

# 629/630 SERIES

Plug and Receptacle, Right Angle, .370" (9.44mm) Footprint



## FEATURES

- Two contact rows with .370" (9.44mm) footprint right angle bend.
- .109" (2.77mm) contact spacing x .112" (2.82mm) row spacing.
- Plug and receptacle in 9-, 15-, 25-, 37-pin contact sizes.
- Pin and socket contact mating design with PC tail termination.
- Metal shell provides EMI/RFI shielding. Plug shell indents provide grounding and additional mating retention.
- Grounding features include two-prong boardlock for exceptional retention to PC board.
- Mounting options for panel mount or connector mating include through-hole, threaded inserts and threaded standoffs.
- D-shaped connector mating outline provides polarization design based on requirements of MIL-C-24308, EIA RS-232 and RS-449.

## SPECIFICATIONS

- Insulator Material: Thermoplastic polyester, UL 94V-0; chemical resistant; colour - black.
- Contact Material: Plug contacts - brass; receptacle contacts - phosphor bronze.
- Contact Plating: Gold (see *Ordering Code*) over nickel for the mating area, tin/lead plating on contact tails.
- Shell Material: Tin/lead plated steel. (nickel optional)
- Current Rating: 5 amperes.
- Contact Resistance: 10 milliohms maximum.
- Dielectric Withstanding Voltage: 1000V AC rms at sea level.
- Insulation Resistance: 5000 megohms minimum.
- Operating Temperature: -55° to +105° C.
- Engagement and Separation Force: 1 to 10 oz. (0.28 to 2.78 N) per contact position.

## 629/630 SERIES ORDERING CODE

Example:

**629-025-240-033**

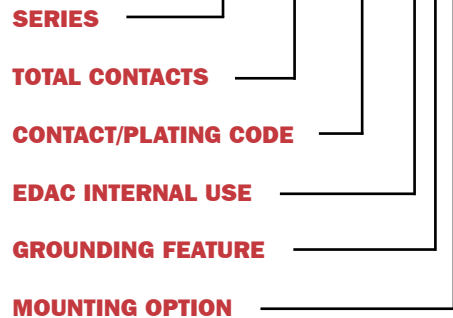

### SERIES

**629** .....Plug  
**630** .....Receptacle

### TOTAL CONTACTS

**009, 015, 025, 37**

### CONTACT/PLATING CODE

**240** .....Gold Flash (Class 3)  
**340** .....15µ" (0.38µm) (Class 2)  
**640** .....30µ" (0.76µm) (Class 1)

### EDAC INTERNAL USE

**0** .....Indicates generic internal use code

### GROUNDING FEATURE

**1** ..... .120" (3.05mm) dia. through hole top ground  
**2** ..... .120" (3.05mm) dia. through hole bottom ground  
**3**... Two-prong boardlock for .120" (3.05mm) dia. PCB hole

### MOUNTING OPTION

**0** .....#4-40 UNC standoff w/ threaded insert  
**1** ..... .125" (3.18mm) dia. through-hole  
**2** .....#4-40 UNC threaded insert  
**3**..... #4-40 UNC hex standoff w/ threaded insert

# 629/630 SERIES

## Plug and Receptacle, Right Angle, .370" (9.44mm) Footprint

### PLUG 629 SERIES

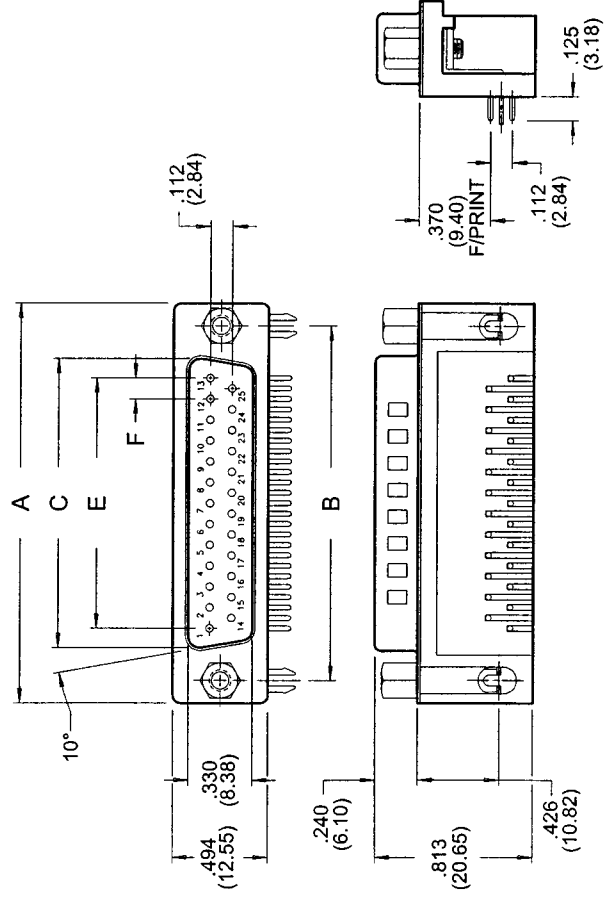

### RECEPTACLE 630 SERIES

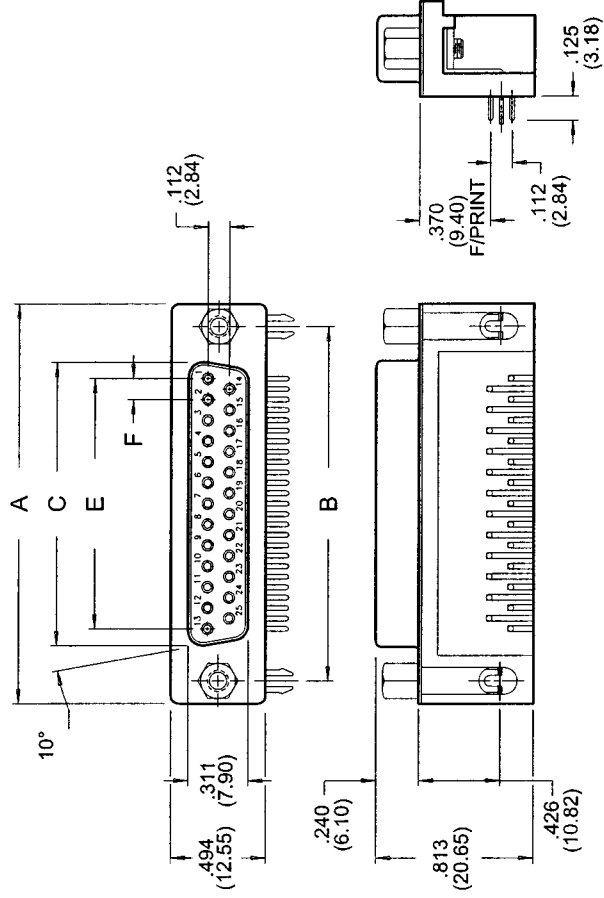

NUMBER OF CONTACTS	A		B		C		RECEPTACLE		E		F	
	Inch	(mm)	Inch	(mm)	Inch	(mm)	Inch	(mm)	Inch	(mm)	Inch	(mm)
9	1.214	(30.84)	.984	(24.99)	.667	(16.92)	.640	(16.26)	.432	(10.97)	.108	(2.74)
15	1.545	(39.24)	1.312	(33.32)	.994	(25.25)	.967	(24.56)	.756	(19.20)	.108	(2.74)
25	2.088	(53.04)	1.852	(47.04)	1.534	(38.96)	1.508	(38.30)	1.304	(33.12)	.109	(2.76)
37	2.730	(69.34)	2.500	(63.50)	2.182	(53.08)	2.156	(54.76)	1.956	(49.68)	.109	(2.76)

# 632 SERIES

Receptacle, Right Angle, High-Density, .125" (3.175mm) Footprint



## 632 SERIES ORDERING CODE

Example:

**632-015-266-033**

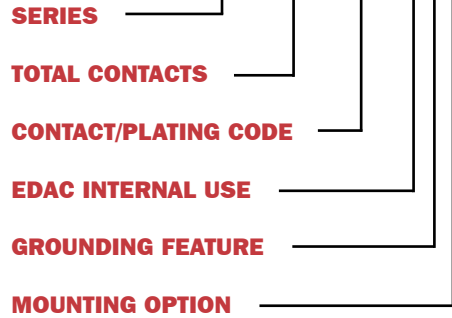

## FEATURES

- High-density three contact rows with .125" (3.175mm) footprint right angle bend.
- .090" (2.29mm) contact spacing x .079" (1.905mm) row spacing.
- Receptacle in 15-pin contact size.
- Socket contact mating design with PC tail termination.
- Metal shell provides EMI/RFI shielding. Plug shell indents provide grounding and additional mating retention.
- Grounding features include two-prong boardlock for exceptional retention to PC board.
- Mounting options for panel mount or connector mating include threaded inserts and threaded standoffs.
- D-shaped connector mating outline provides polarization design based on requirements of MIL-C-24308, EIA RS-232 and RS-449.

## SPECIFICATIONS

- Insulator Material: Thermoplastic polyester, UL 94V-0; chemical resistant; colour - black.
- Contact Material: receptacle contacts - phosphor bronze.
- Contact Plating: Gold (see *Ordering Code*) over nickel for the mating area, tin/lead plating on contact tails.
- Shell Material: Nickel plated steel.
- Current Rating: 5 amperes.
- Contact Resistance: 10 milliohms maximum.
- Dielectric Withstanding Voltage: 1000V AC rms at sea level.
- Insulation Resistance: 5000 megohms minimum.
- Operating Temperature: -55° to +105° C.
- Engagement and Separation Force: 1 to 10 oz. (0.28 to 2.78 N) per contact position.

### SERIES

**632** ..... Receptacle

### TOTAL CONTACTS

**015**

### CONTACT/PLATING CODE

**266** ..... Gold Flash (Class 3)  
**366** ..... 15µ" (0.38µm) (Class 2)  
**566** ..... 10µ" (0.25µm) (Class 2)  
**666** ..... 30µ" (0.76µm) (Class 1)

### EDAC INTERNAL USE

**0** ..... Indicates generic internal use code

### GROUNDING FEATURE

**3** .... Two-prong boardlocks for .120" (3.05) dia. hole

### MOUNTING OPTION

**2** ..... #4-40 UNC threaded insert  
**3** .... #4-40 UNC threaded standoff w/ threaded insert

632 SERIES

RECEPTACLE 632 SERIES

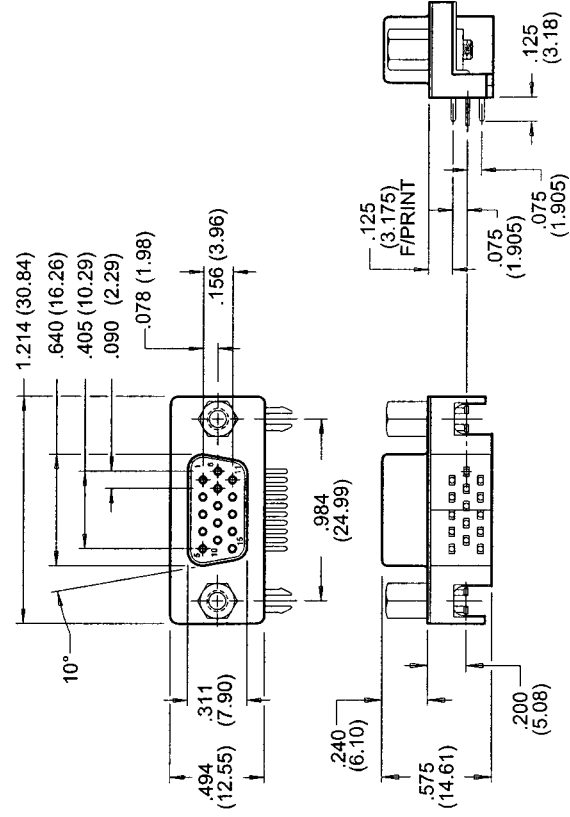



# 633/634 SERIES



## 633/634 SERIES ORDERING CODE

**Example:**

634-015-632-042

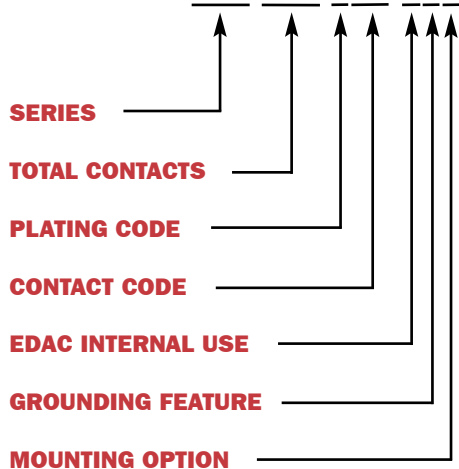

### FEATURES

- High-density three contact rows with .350" (8.89mm) footprint right angle bend.
- .090" (2.29mm) contact spacing x .078" (1.98mm) row spacing.
- Optional 9th contact recessed by .050" (1.27mm) on 15-pin part, in accordance with VESA Display Data Channel Standard.
- Receptacles and plugs 15-, 26-, 44-, 62- and 78-pin contact sizes.
- Socket contact mating design with PC tail termination.
- Metal shell provides EMI/RFI shielding. Plug shell indents provide grounding and additional mating retention.
- Grounding features include top or bottom ground plates and two- or four-prong boardlock for exceptional retention to PC board.
- Mounting options for panel mount or connector mating include through-hole, threaded inserts and threaded standoffs.
- D-shaped connector mating outline provides polarization design based on requirements of MIL-C-24308, EIA RS-232 and RS-449.

### SPECIFICATIONS

- Insulator Material: Thermoplastic polyester, UL 94V-0; chemical resistant; colour - black or blue.
- Ferrite Specifications: Attenuation - 17dB MIN @ 30Mhz, 25dB MIN @ 50Mhz and 40dB @ 100Mhz.
- Contact Material: receptacle contacts - phosphor bronze.
- Contact Plating: Gold (see *Ordering Code*) over nickel for the mating area, tin/lead plating on contact tails.
- Shell Material: Tin/lead plated steel.
- Current Rating: 5 amperes.
- Contact Resistance: 10 milliohms maximum.
- Dielectric Withstanding Voltage: 1000V AC rms at sea level.
- Insulation Resistance: 5000 megohms minimum.
- Operating Temperature: -55° to +105° C.
- Engagement and Separation Force: 1 to 10 oz. (0.28 to 2.78 N) per contact position.

#### SERIES

- 633** .....Plug
- 634**.....Receptacle

#### TOTAL OF CONTACTS

**015, 026, 044, 062 (078 - Female Only)**

#### PLATING CODE

- 2** .....Gold Flash (Class 3)
- 5** .....10µ" (0.25µm) (Class 2)
- 6** .....30µ" (0.76µm) (Class 1)

#### CONTACT CODE

- 63** .....Standard contacts, black plastic
- 68** .....Ferrite filter
- 73** ...9th contact recessed .050" (1.27mm), black insulator
- 74** ...9th contact recessed .050" (1.27mm), blue insulator

#### EDAC INTERNAL USE

- 0** .....Indicates generic internal use code

#### GROUNDING FEATURE

- 1** ..... .120" (3.05mm) dia. through-hole top ground
- 2** .. .120" (3.05mm) dia. through-hole bottom ground (633)
- 3** ....Two-prong boardlocks for .120" (3.05mm) dia. hole
- 4** ...Four-prong boardlocks for .120" (3.05mm) dia. hole
- 9** .....High-temperature four-prong boardlocks

#### MOUNTING OPTION

- 0** .....#4-40 UNC standoff w/ threaded insert
- 1**......125" (3.18mm) dia. through-hole
- 2**.....#4-40 UNC threaded insert
- 3**.....#4-40 UNC hex standoff w/ threaded insert

# Plug and Receptacle, Right Angle, High-Density, .350" (8.89mm) Footprint

## 633/634 SERIES

### PLUG 633 SERIES

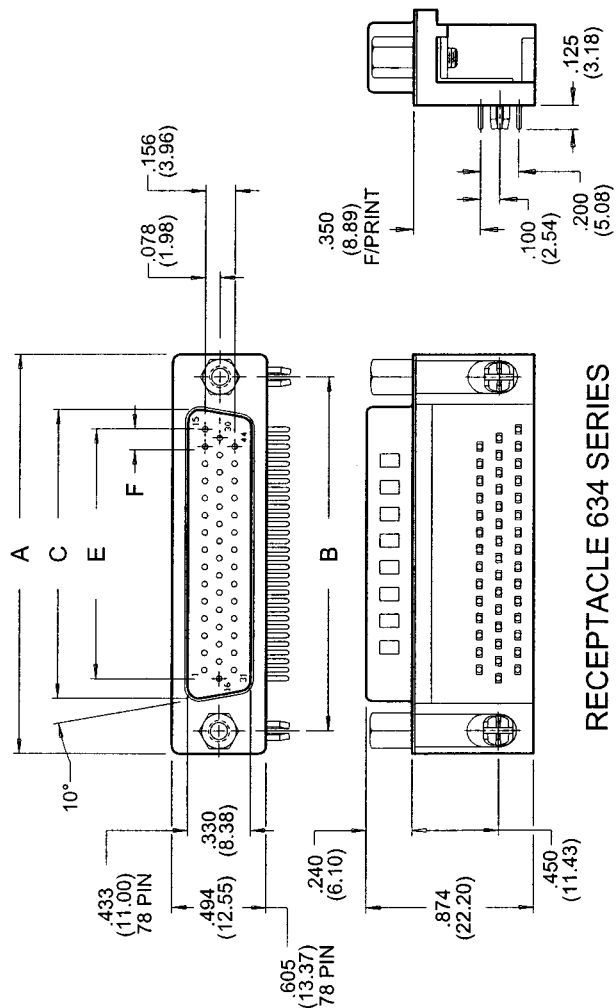

### RECEPTACLE 634 SERIES

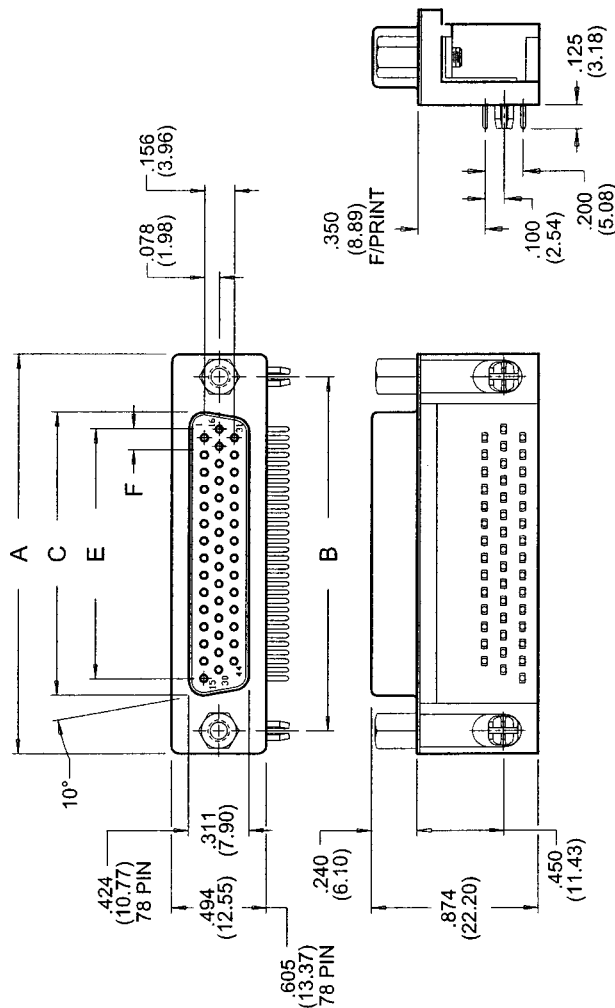

NUMBER OF CONTACTS	A		B		C PLUG		C RECEPTACLE		E		F	
	Inch	(mm)	Inch	(mm)	Inch	(mm)	Inch	(mm)	Inch	(mm)	Inch	(mm)
15	1.214	(30.84)	.984	(24.99)	.667	(16.92)	.640	(16.26)	.405	(10.29)	.090	(2.29)
26	1.545	(39.24)	1.312	(33.32)	.994	(25.25)	.967	(24.56)	.765	(19.43)	.090	(2.29)
44	2.088	(53.04)	1.852	(47.04)	1.534	(38.96)	1.508	(38.30)	1.305	(33.15)	.090	(2.29)
62	2.730	(69.34)	2.500	(63.50)	2.182	(55.42)	2.156	(54.76)	1.947	(49.45)	.095	(2.41)
78	2.635	(66.93)	2.406	(61.11)	2.090	(53.08)	2.064	(52.43)	1.805	(45.85)	.095	(2.41)

# 637/638 SERIES



## 637/638 SERIES ORDERING CODE

**Example:**

637-015-230-047

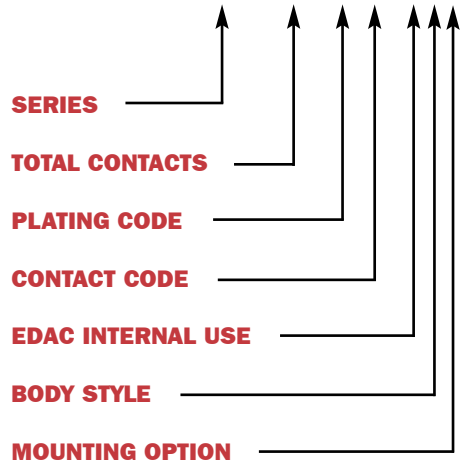

### FEATURES

- High profile available in machine contacts. (15- and 26-pin contacts only)
- .090" (2.29mm) contact spacing x .078" (1.98mm) row spacing.
- Plug and receptacle in 15-, 26-, 44-, 62- and 78-pin contact sizes.
- Pin and socket contact mating design with PC tail termination.
- Metal shell provides EMI/RFI shielding. Plug shell indents provide grounding and additional mating retention.
- Grounding features include two-prong boardlock for exceptional retention to PC board.
- Mounting options for panel mount or connector mating include through-hole, threaded inserts boardlocks and removable or fixed threaded standoffs.
- D-shaped connector mating outline provides polarization design based on requirements of MIL-C-24308, EIA RS-232 and RS-449.

### SPECIFICATIONS

- Insulator Material: Thermoplastic polyester, UL 94V-0; chemical resistant; colour - black.
- Ferrite Specifications: Attenuation - 20dB MIN @ 30Mhz, 30dB MIN @ 50Mhz and 50dB MIN @ 100Mhz.
- Contact Material: Plug - brass; receptacle contacts - phosphor bronze.
- Contact Plating: Gold (see *Ordering Code*) over nickel for the mating area, tin/lead plating on contact tails.
- Shell Material: Nickel-plated steel. (Tin/lead optional)
- Current Rating: 5 amperes.
- Contact Resistance: 10 milliohms maximum.
- Dielectric Withstanding Voltage: 1000V AC rms at sea level.
- Insulation Resistance: 5000 megohms minimum.
- Operating Temperature: -55° to +105° C.
- Engagement and Separation Force: 1 to 10 oz. (0.28 to 2.78 N) per contact position.

#### SERIES

**637** .....Plug  
**638** .....Receptacle

#### TOTAL CONTACTS

**015, 026, 044, 062, 078**

#### PLATING CODE

**2** .....Gold Flash (Class 3)  
**3** .....15µ" (0.38µm) (Class 2)  
**6** .....30µ" (0.76µm) (Class 1)

#### CONTACT CODE

**30** .....Low profile PC tails, .157" (4.00mm)  
**31** .....High profiles PC tails, .169" (4.30mm)  
**22/32** .....Solder cup

#### EDAC INTERNAL USE

**0** .....Indicates generic internal use code

#### BODY STYLE

**4** .....Metal covered .276" (7.00mm) low profile  
**5** .....Metal covered .472" (12.00mm) high profile (15-/26-pin)

#### MOUNTING OPTION

**1** ..... .125" (3.18mm) dia. through-hole  
**2** .....#4-40 UNC threaded inserts  
**3** .....#4-40 UNC threaded standoffs  
**6** .....#4-40 UNC threaded insert w/ boardlocks  
**7** .....#4-40 UNC threaded standoff w/ boardlocks  
**8** .....#4-40 UNC threaded fixed standoffs

# 637/638 SERIES

## Plug and Receptacle, Vertical High-Density, PCB Mount, Metal Body

### LOW PROFILE      PLUG 637 SERIES      HIGH PROFILE

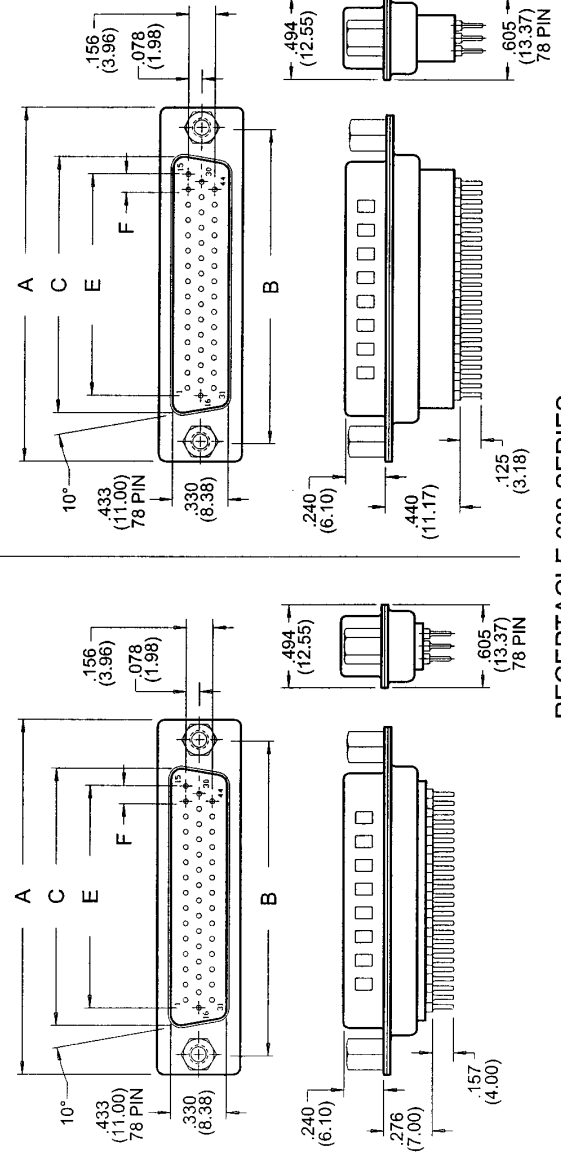

### RECEPTACLE 638 SERIES

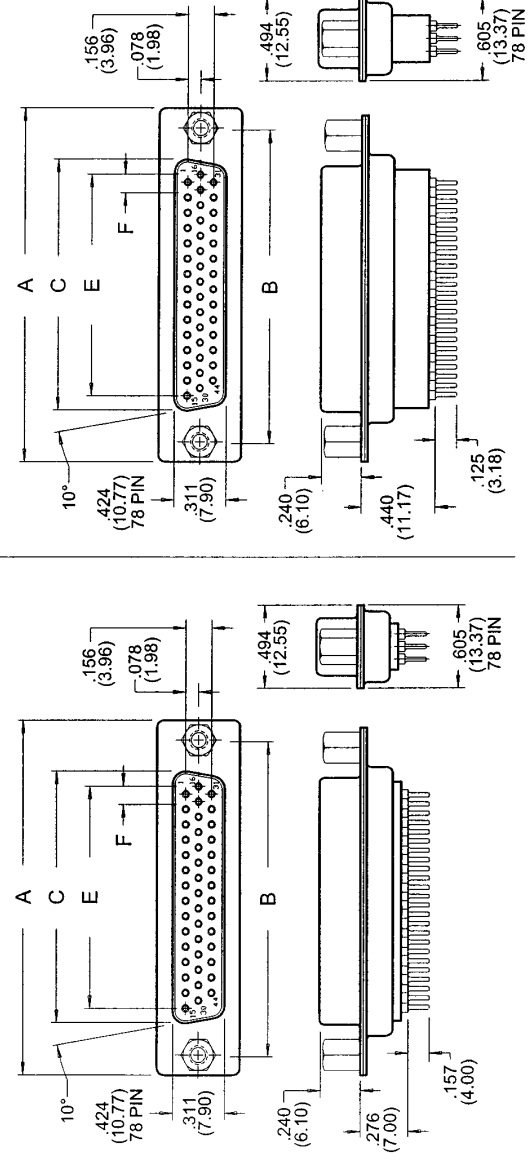

NUMBER OF CONTACTS	A		B		C PLUG		C RECEPTACLE		E		F	
	Inch	(mm)	Inch	(mm)	Inch	(mm)	Inch	(mm)	Inch	(mm)	Inch	(mm)
15	1.214	(30.84)	.984	(24.99)	.667	(16.92)	.640	(16.26)	.405	(10.29)	.090	(2.29)
26	1.545	(39.24)	1.312	(33.32)	.994	(25.25)	.967	(24.56)	.765	(19.43)	.090	(2.29)
44	2.088	(53.04)	1.852	(47.04)	1.534	(38.96)	1.508	(38.30)	1.305	(33.15)	.090	(2.29)
62	2.730	(69.34)	2.500	(63.50)	2.182	(55.42)	2.156	(54.76)	1.947	(49.45)	.095	(2.41)
78	2.635	(66.93)	2.406	(61.11)	2.090	(53.08)	2.064	(52.43)	1.805	(45.85)	.095	(2.41)

# 661/662/663/664 SERIES



## FEATURES

- Two contact rows per connector with right angle bend.
- Plug and receptacle in 9-, 15-, 25- or 37-pin contact sizes.
- Pin and socket contact mating design with PC tail termination.
- Metal shell provides EMI/RFI shielding. Plug shell indents provide grounding and additional mating retention.
- Grounding features include grounding bracket and two-prong boardlock for exceptional retention to PC board.
- Mounting options for panel mount or connector mating include through-hole, threaded inserts and threaded standoffs.
- D-shaped connector mating outline provides polarization design based on requirements of MIL-C-24308, EIA RS-232 and RS-449.

## SPECIFICATIONS

- Insulator Material: Thermoplastic polyester, UL 94V-0; chemical resistant; colour - black.
- Ferrite Specifications: Attenuation - 20dB MIN @ 30Mhz, 30dB MIN @ 50Mhz and 50dB MIN @ 100Mhz.
- Contact Material: Plug contacts - brass; receptacle contacts - phosphor bronze.
- Contact Plating: Gold (see *Ordering Code*) over nickel for the mating area, tin/lead plating on contact tails.
- Shell Material: Tin/lead plated steel.
- Current Rating: 5 amperes.
- Contact Resistance: 10 milliohms maximum.
- Dielectric Withstanding Voltage: 1000V AC rms at sea level.
- Insulation Resistance: 5000 megohms minimum.
- Operating Temperature: -55° to +105° C.
- Engagement and Separation Force: 1 to 10 oz. (0.28 to 2.78 N) per contact position.

## 661 - 664 SERIES ORDERING CODE

Example:

661-025-264-013

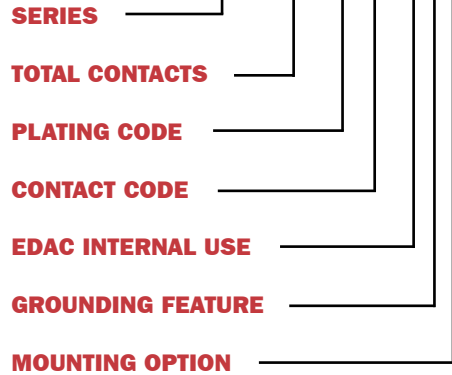

<b>SERIES</b>	
<b>661</b> .....	Plug over plug
<b>662</b> .....	Receptacle over receptacle
<b>663</b> .....	Plug over receptacle
<b>664</b> .....	Receptacle over plug

<b>TOTAL CONTACTS</b>	
<b>009, 015, 025, 037, 050</b>	

<b>PLATING CODE</b>	
<b>2</b> .....	Gold Flash (Class 3)
<b>3</b> .....	.15µ" (0.38µm) (Class 2)
<b>6</b> .....	.30µ" (0.76µm) (Class 1)

<b>CONTACT CODE</b>	
<b>64</b> .....	Regular density connectors
<b>67</b> .....	25-pin female/SCSI II 50 female
<b>68</b> .....	Ferrite filter (9- and 25-pin only)
<b>69</b> .....	Any high-density connector combination

<b>EDAC INTERNAL USE</b>	
<b>0</b> ...	.150" (3.81mm) between upper/lower contact rows
<b>0</b> .....	.160" (4.06mm) between upper/lower contact rows

<b>GROUNDING FEATURE</b>	
<b>1</b> .....	.125" (3.18mm) dia. through-hole
<b>3</b> .....	Two-prong boardlocks for PCB hole
<b>5</b> .....	#4-40 UNC threaded mounting hole
<b>7</b> .....	Rear only two-prong boardlocks

# 661/662/663/664 SERIES

## MOUNTING OPTION

- 2 ..... .625" (15.88mm) #4-40 unified threaded insert
- 3 .. .625" (15.88mm) #4-40 unified threaded hex standoff
- 4..... .625" (15.88mm) .125" clear hole insert
- 5 ..... .750" (19.05mm) #4-40 unified threaded insert

- 6 .. .750" (19.05mm) #4-40 unified threaded hex standoff
- 7 ..... .750" (19.05mm) .125" clear hole insert
- 8 ..... .900" (22.86mm) #4-40 unified threaded insert
- 9 .. .900" (22.86mm) #4-40 unified threaded hex standoff
- 0..... .900" (22.86) .125" clear hole insert

### PLUG/PLUG 661 SERIES

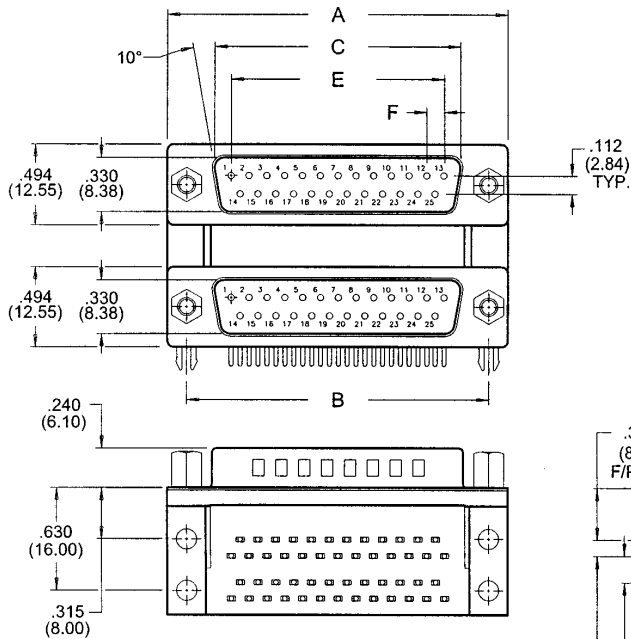

### RECEPTACLE/RECEPTACLE 662 SERIES

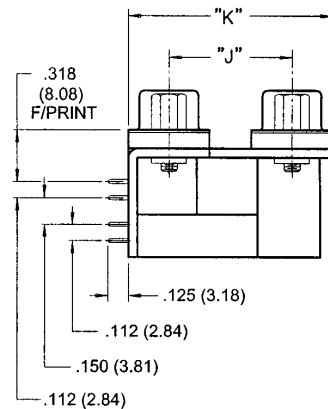
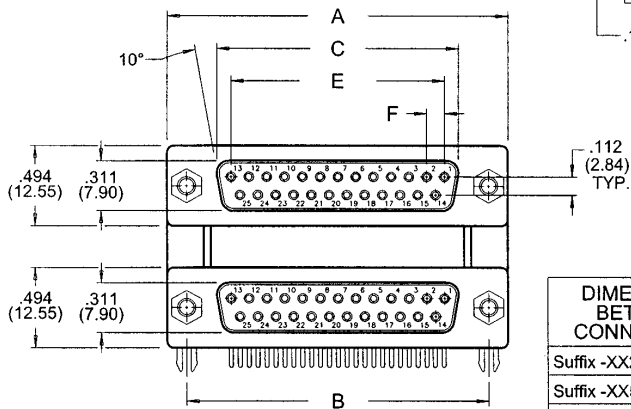

DIMENSIONS BETWEEN CONNECTORS	J		K	
	Inch	(mm)	Inch	(mm)
Suffix -XX2, -XX3, -XX4	.625	(15.88)	1.119	(28.42)
Suffix -XX5, -XX6, -XX7	.750	(19.05)	1.244	(31.60)
Suffix -XX8, -XX9, -XX0	.900	(22.86)	1.394	(35.41)

NUMBER OF CONTACTS	A		B		C PLUG		C RECEPTACLE		E		F	
	Inch	(mm)	Inch	(mm)	Inch	(mm)	Inch	(mm)	Inch	(mm)	Inch	(mm)
9	1.214	(30.84)	.984	(24.99)	.667	(16.92)	.640	(16.26)	.432	(10.97)	.108	(2.74)
15	1.545	(39.24)	1.312	(33.32)	.994	(25.25)	.967	(24.56)	.756	(19.20)	.108	(2.74)
25	2.088	(53.04)	1.852	(47.04)	1.534	(38.96)	1.508	(38.30)	1.304	(33.12)	.109	(2.76)
37	2.730	(69.34)	2.500	(63.50)	2.182	(55.42)	2.156	(54.76)	1.956	(49.68)	.109	(2.76)

Plug and Receptacle Combination, Dual Port, Right Angle Connectors

# GROUNDING AND MOUNTING OPTIONS

## GROUNDING FEATURES FOR DUAL PORT P.C.B.

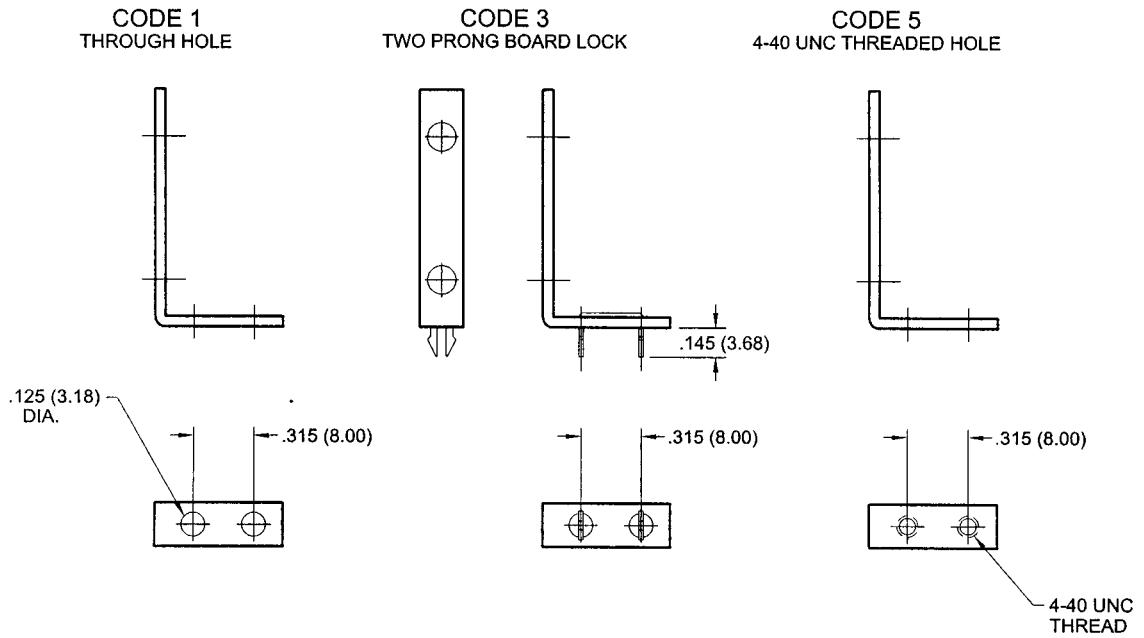

## MOUNTING OPTIONS FOR DUAL PORT P.C.B.

- |  |  |
|--|--|
| <p><b>CODE 2</b><br/>THREADED INSERT, J= .625 (15.88)</p> <p><b>CODE 5</b><br/>THREADED INSERT, J= .750 (19.05)</p> <p><b>CODE 8</b><br/>THREADED INSERT, J= .900 (2.86)</p> | <p><b>CODE 3</b><br/>THREADED STANDOFF, J= .625 (15.88)</p> <p><b>CODE 6</b><br/>THREADED STANDOFF, J= .750 (19.05)</p> <p><b>CODE 9</b><br/>THREADED STANDOFF, J= .900 (2.86)</p> |
|--|--|

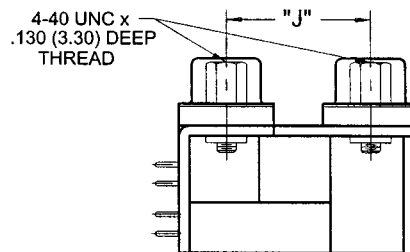
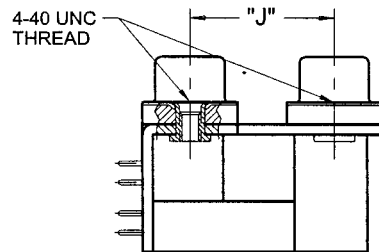

### OPTIONS HARDWARE FOR RIGHT ANGLE P.C.B.

#### GROUNDING

CODE 1

TOP GROUND PLATE

.120 (3.05)  
DIA

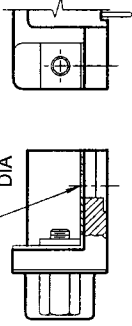

#### MOUNTING

CODE 0

FIXED ROUND STANDOFF  
WITH THREADED INSERT

.220  
(5.59)

#4-40 UNC x  
.160 (4.06) DEEP  
THREAD

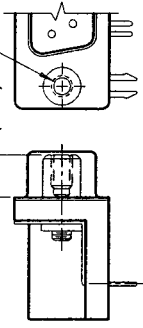

CODE 3

TWO PRONG BOARD LOCK

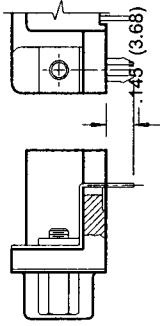

CODE 1

THROUGH HOLE

.125 (3.18)  
THROUGH HOLE

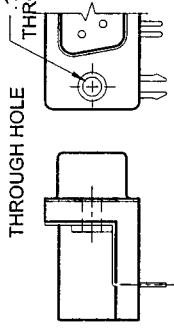

CODE 4

FOUR PRONG BOARD LOCK

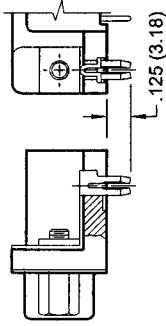

CODE 2

THREADED HOLE

#4-40 UNC  
THREADED HOLE

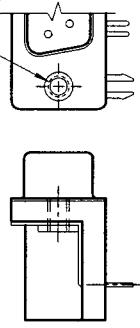

CODE 3

THREADED HEX STANDOFF  
WITH THREADED INSERT

.220  
(5.59)

#4-40 UNC x  
.160 (4.06) DEEP  
THREAD

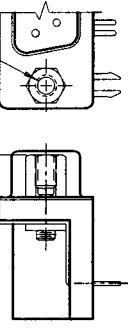



# GROUNDING AND MOUNTING OPTIONS

## MOUNTING OPTIONS FOR STRAIGHT P.C.B.

**CODE 1**  
THROUGH HOLE

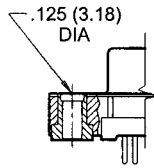

**CODE 6 (PLASTIC BODY)**  
THREADED INSERT/ BOARD LOCK

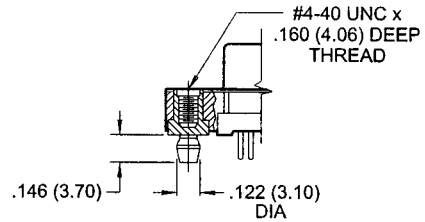

**CODE 2**  
THREADED INSERT

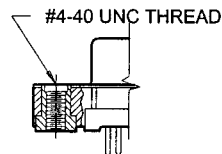

**CODE 6 (METAL BODY)**  
THREADED INSERT/BOARD LOCK

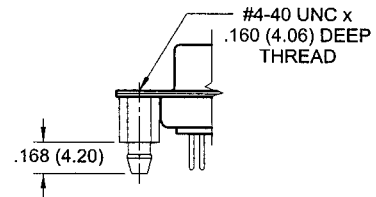

**CODE 3**  
THREADED STANDOFF

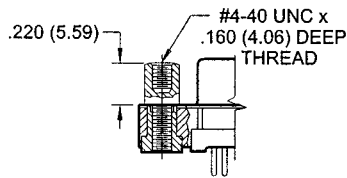

**CODE 7 (PLASTIC BODY)**  
THREADED STANDOFF/BOARD LOCK

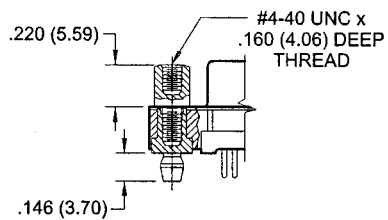

**CODE 4**  
THREADED INSERT/DIP SOLDER PRONG

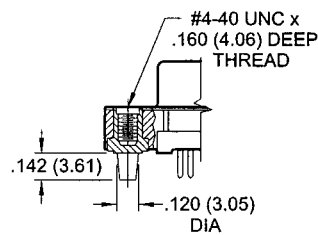

**CODE 7 (METAL BODY)**  
THREADED STANDOFF/BOARD LOCK

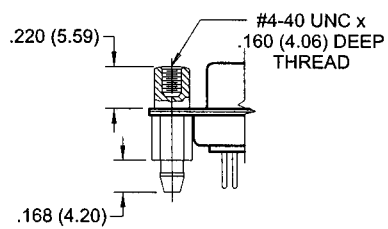

**CODE 5**  
THREADED STANDOFF/DIP SOLDER PRONG

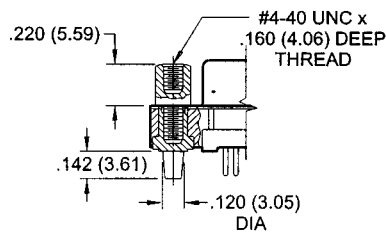

**CODE 8**  
THREADED FIXED STANDOFF

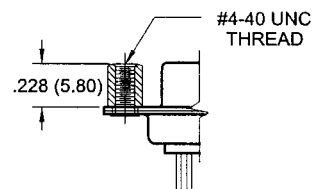

# HOLE PATTERN RECOMMENDED

Series 619, 620, 621, 622, 627, 628, 629, 630

FOR SERIES 619, 620, 621, 622, 627, 628, 629 AND 630

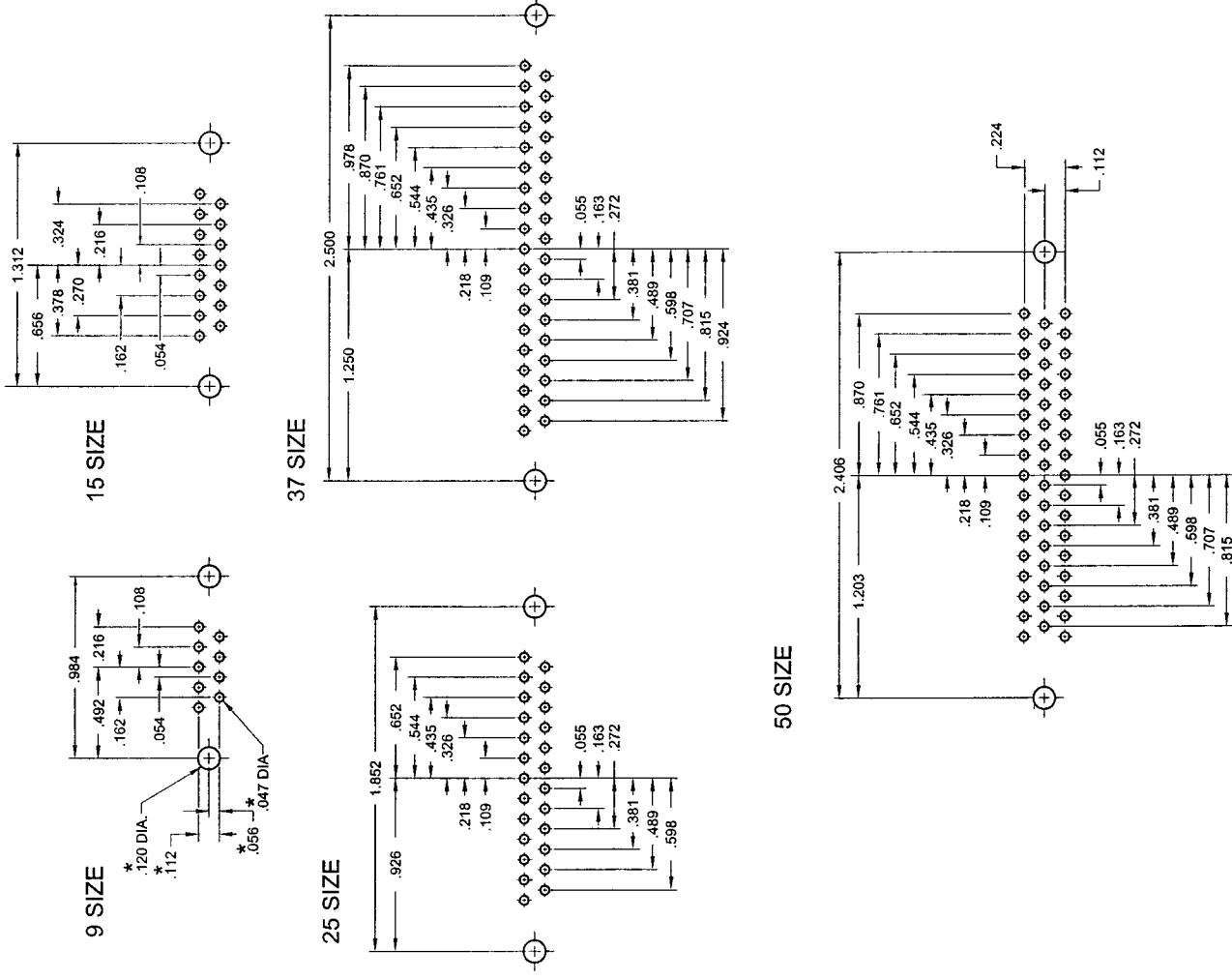

\* TYP. ON ALL PATTERNS

# HOLE PATTERN RECOMMENDED

FOR SERIES 625 AND 626

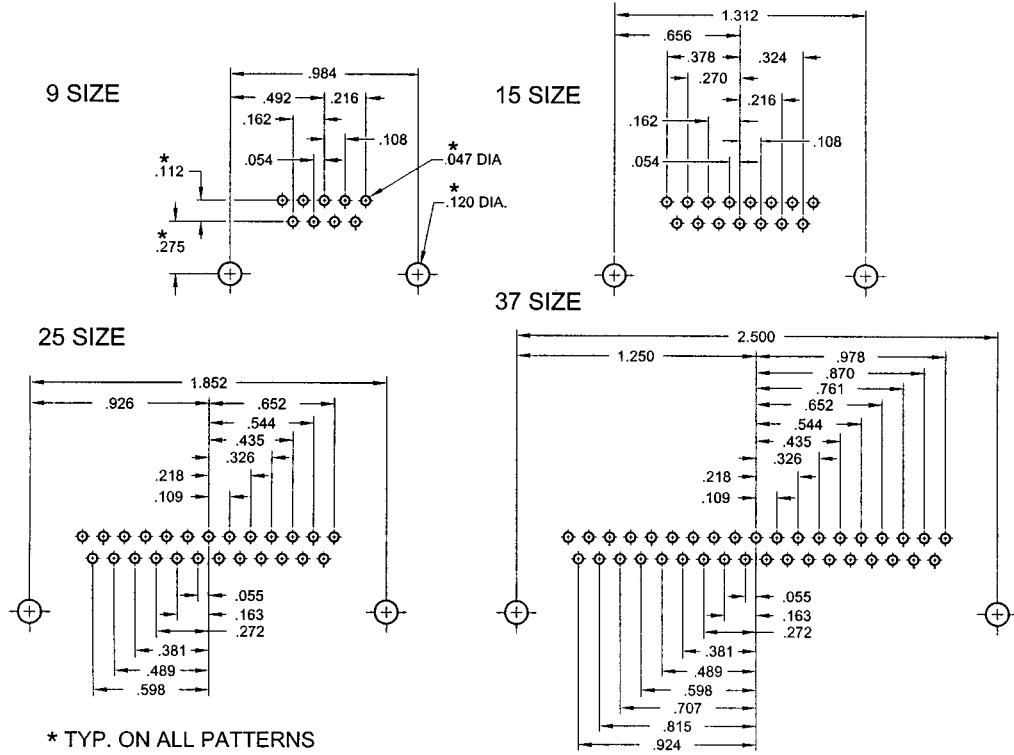

FOR SERIES 623 AND 624

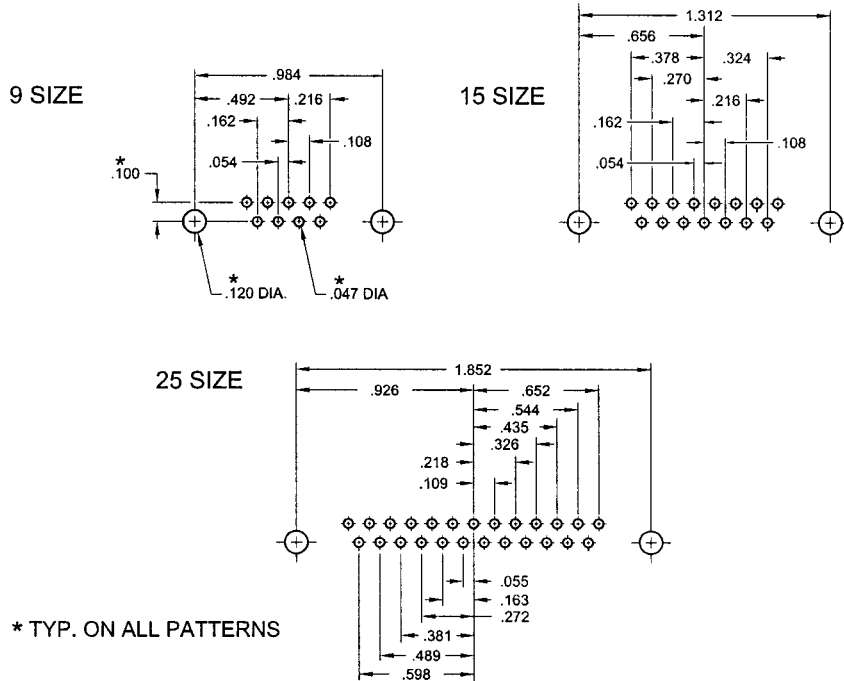

Series 625, 626

# HOLE PATTERN RECOMMENDED

FOR SERIES 633 AND 634  
 HOLE PATTERN SHOWN ARE FOR 634  
 HOLE PATTERN FOR 633 ARE MIRROR IMAGE

15 SIZE

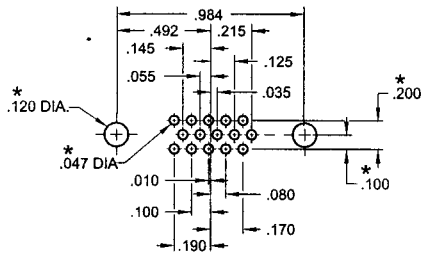

26 SIZE

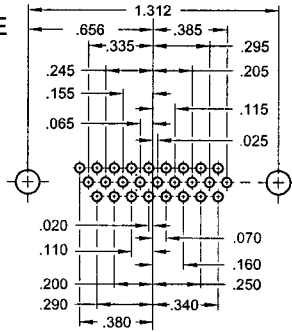

44 SIZE

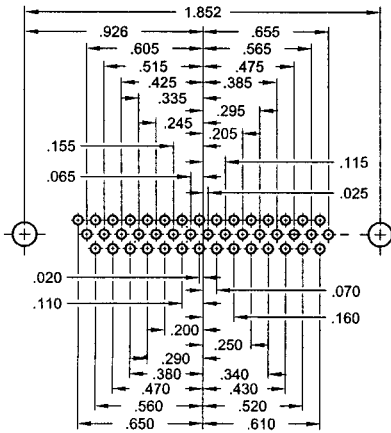

62 SIZE

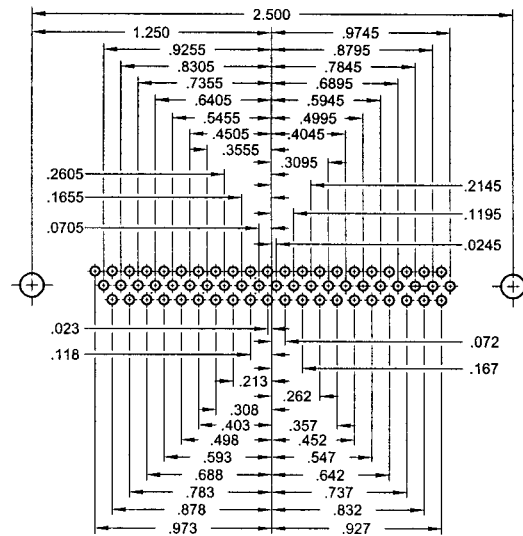

78 SIZE

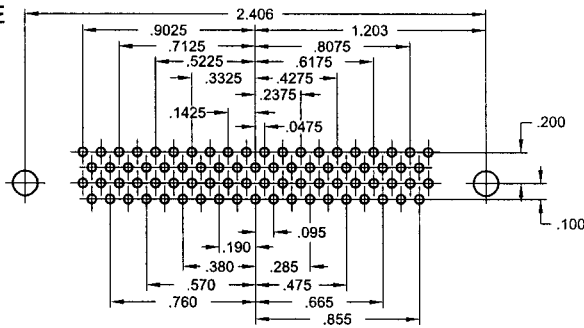

\* TYP. ON ALL PATTERNS

Series 633, 634

# HOLE PATTERN RECOMMENDED

FOR SERIES 632, 637 AND 638  
 HOLE PATTERN SHOWN ARE FOR 632 AND 638  
 HOLE PATTERN FOR 637 ARE MIRROR IMAGE

15 SIZE

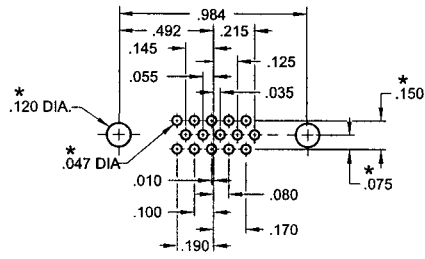

26 SIZE

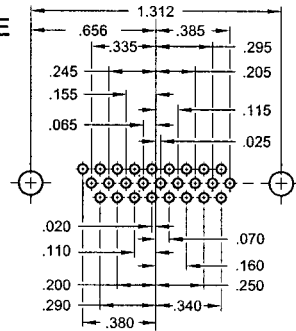

44 SIZE

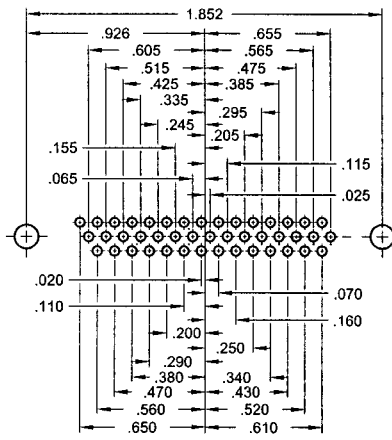

62 SIZE

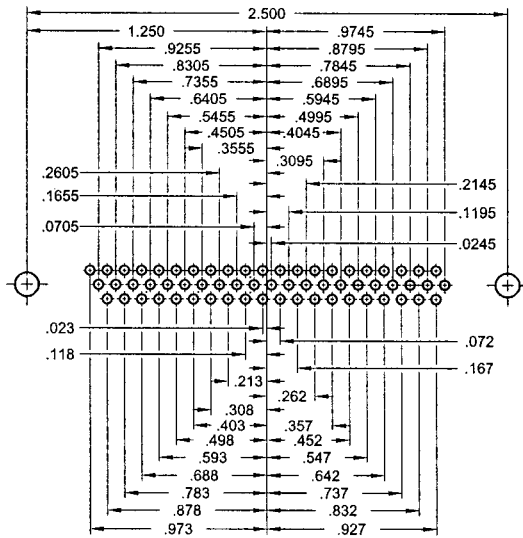

78 SIZE

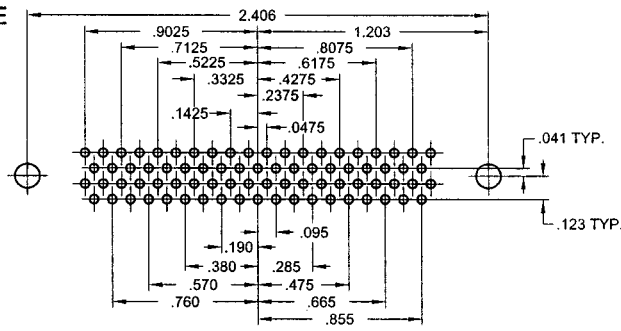

\* TYP. ON ALL PATTERNS

Series 632, 637, 638

## INSULATOR MOLDING MATERIALS

EDAC offers a wide range of insulator materials including polyester, polyphenylene sulfide, polycarbonate, liquid crystal polymer and nylon. If a specific material is required to suit your application, please consult with EDAC.

All of the molding materials used by EDAC have excellent mechanical, electrical and thermal properties. Some of the notable differences between the material characteristics are as follows:

- 1 Polyphenylene sulfide and high temperature nylon (6T) are capable of being used in vapour phase or infra-red soldering applications. Frequently these materials are also used in burn-in applications up to 150° C.
- 2 Liquid Crystal Polymer (LCP) is often used to mold extremely fine detailed parts.
- 3 In general, chemical resistance is excellent for all the materials, except polycarbonate. With polycarbonate, chemicals such as amines, aromatic or halogenated hydrocarbons, esters and ketones should be avoided.
- 4 The flammability rating is UL94V-0 for all materials, except for polycarbonate which is rated at UL94V-2.

## CONTACT MATERIALS

Contact base materials are either brass phosphor bronze alloy CA-510 or copper, nickel, tin alloy CA-725. These materials have been widely used and accepted in the electronics industry for many years. They offer an excellent blend of electrical, mechanical and corrosion resistance characteristics at a reasonable cost.

Phosphor bronze alloy CA-510, (Federal Specification QQ-B-750, Grade A) consists of 94.8% copper, 5% tin and 0.2% phosphorus.

Copper, nickel, tin alloy CA-725, (ASTM B-122, Copper alloy UNS No. C72500) consists of 88.2% copper, 9.5% nickel and 2.3% tin. This material has the added benefit of remaining solderable in the unplated condition for an extended period of time.

## CONTACT FINISH (PLATING & GOLD INLAY)

The standard contact finishes offered include:

- 1 Selective plating - nickel overall followed by gold on the contact mating area and tin/lead alloy on the contact tails.
- 2 Overall plating - gold over nickel or tin/lead alloy.

With this manufacturing flexibility, EDAC can also provide contact finishes to meet specific requirements. Examples of special platings regularly performed include various plating thicknesses and selectively plated gold on both the mating area and the contact tail.

## METAL HARDWARE MATERIALS

The majority of metal hardware such as threaded inserts, bushings and actuating screws are nickel-plated brass or steel. Some hardware is available in stainless steel. Consult with EDAC if specific details are required.

## UNDERWRITERS' LABORATORY (UL)

Connectors recognized by UL are listed under UL File No. E62838. Consult with EDAC if additional product listings are required.

## WIRE DATA

Diameters of wire sizes commonly used with EDAC connectors are summarized below. The actual stranded wire diameter is dependant upon the number of strands and individual strand guide.

## SPECIAL VARIATION CONNECTORS

For over 30 years EDAC has manufactured a wide selection of special connectors. In the part numbering system, they are identified as special by the last group of digits in the part number.

**Example:**

**345-015-274-901**

**SPECIAL VARIATION ID CODE**

No.3 - for Series 100 to 438  
No.9 - for Series 516 to 746

**UNIQUE LISTING CODE**

This number is assigned by EDAC. Note that connector part number 345-015-274-900 may have completely different features than the part number in the above example.

Some examples of special connector features previously used in manufacturing include:

- Special contact assembly patterns.
- Polarizing key installed or molded into position.
- Cost saving options such as no part marking.
- Material and plating options.
- Special insulator dimensions (length, width, height, mounting).
- Insulator features such as open card slot ends.
- Special contact bends, boardlock forms, tail lengths.
- Customer part number marking.
- Specific quality requirements or testing.
- Specific control on insertion and withdrawal forces.
- Mounting features such as side holes through card guides.
- Special rack and panel polarization or cover designs.

If you have any unique or unusual connector requirements, discuss them with the specialists at EDAC, where your connector needs can become reality.

## ENVIRONMENTAL RESPONSIBILITY

EDAC's products and manufacturing processes are free of ozone depleting substances (CFCs and HCFCs) as listed by the Environmental Protection Agency. In addition, waste water quality management and 3R (reduce, reuse and recycle) programs form part of the EDAC commitment to environmental responsibility.

## GENERAL NOTES

- 1 Dimensional drawings are presented using orthographic third angle projection.
- 2 Abbreviations used in this catalog include:

AWG.....	American Wire Gauge
C.....	Celsius
CSA.....	Canadian Standards Association
Dia. ....	Diameter
EISA .....	Extended Industry Standard Architecture
ID.....	Inside Diameter
ISA.....	Industry Standard Architecture
kN.....	Kilonewton
kPa .....	Kilopascal
lbs. ....	Pounds
MCA.....	Microchannel Architecture
mm .....	Millimetres
N .....	Newton
oz. ....	Ounce
PC.....	Printed Circuit
P/N.....	Part Number
psi.....	Pounds per square inch
rms .....	Root mean squared
V AC.....	Volts, Alternating Current
UL.....	Underwriters Laboratories
UNC .....	Unified Coarse
μ" .....	Microinches
μm .....	Microns

- 5 EDAC is a licensed user of the connector design technology that permits the use of flat rock tooling for the installation of the compliant pin card edge connectors.
- 6 Every effort has been made to ensure the accuracy of information within this catalog. When changes or corrections are necessary, trade announcements are made to customers, distributors or representatives of EDAC. Readers of this catalog are invited to offer suggestions for improvements to future publications.

# ENGINEERING NOTES

## PLATING CODE SPECIFICATIONS

	Class I	Class II	Class III
<b>Temperature Rating</b>	-65°C to +150°C	-65°C to +125°C	-55°C to +105°C
<b>Durability Ref. TP09 (IPC 3.4)</b>	500 Cycles	250 Cycles	100 Cycles
<b>Contact Wear Evaluation</b>	5% Salt. Solution for 48 hours	5% Salt Solution for 48 hours	N/A
<b>Contact Resistance Ref. TP06 (IPC 3.1)</b>	10 Milliohms	10 Milliohms	25 Milliohms

## THERMAL PROPERTIES OF INSULATOR MOLDING MATERIALS

	Heat Deflection Temperature		Max. Service Temperature	
	At 66 psi	At 264 psi	Inter. use	Cont. use
<b>Nylon</b>	142°F to 510°F	104°F to 500°F	150°F to 375°F	149°F to 326°F
<b>Polycarbonate</b>	275°F to 310°F	260°F to 300°F	250°F to 270°F	220°F to 270°F
<b>Polyester, PET</b>	---	435°F to 450°F	---	---
<b>Polyester, PBT</b>	158°F to 450°F	145°F to 450°F	---	280°F
<b>Polyphenylene Sulfide</b>	500°F to 540°F	285°F to 510°F	450°F to 480°F	360°F to 450°F