



PROTECTION MODULE

- One Input and Four Current Monitored and Limited Outputs
- Ensures Sufficient Supply Voltage for Critical Loads even in the Event of an Fault
- Protects Small Cable Sizes against Overload
- Hassle-free Turn-on of Loads with Large Input Capacitors
- Avoids False Triggering
- Wide Temperature Range between -25°C and +60°C
- Turn-on and Shut-down Function of Outputs
- Compact Design, Width only 45mm
- Integrated Control for Remote Monitoring and Operation
- 3 Year Warranty

GENERAL DESCRIPTION

For the first time, the PISA protection module also protects the 24V supply voltage besides the output current of the connected loads. This feature is unique to PULS and unlike other commonly available protection modules on the market.

A safeguard circuit in the input stage of the PISA module works like a valve. It permits only so much current that the input voltage (corresponding to the power supply output voltage) does not drop below 21V.

This ensures a safe and an uninterrupted supply voltage for sensitive loads even when they are connected to the same power supply as the PISA module. Less critical loads that are not affected to short voltage interruptions or that could even be the cause of a fault on the 24V power supply are connected to one of the four current monitored and limited output channels of the PISA module.

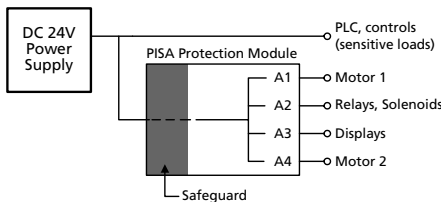

SHORT-FORM DATA

Input voltage	DC 24V	
Input voltage range	18 - 30V	
Input current	typ. 46mA	At no load
Number of outputs	4	
Output currents	fixed between 1A and 10A	See order information
Input voltage protection levels	typ. 21.4V min. 20.7V	
Temperature range	-25°C to +60°C	Operational
	-40°C to +85°C	Non-operational
Type of current limitation	Active current limitation followed by a switch-off	
Dimensions	45x75x91mm *) WxHxD	

*) Add 13mm in depth for signal connector.

ORDER NUMBERS

Protection module	Output Ratings
PISA10.401	1A, 1A, 1A, 1A
PISA10.402	2A, 2A, 2A, 2A
PISA10.403	3A, 3A, 3A, 3A
PISA10.404	4A, 4A, 4A, 4A
PISA10.406	6A, 6A, 6A, 6A
PISA10.410	10A, 10A, 10A, 10A
PISA10.203206	3A, 3A, 6A, 6A
PISA10.206210	6A, 6A, 10A, 10A

MARKINGS



INDEX

	Page		Page
1. Intended Use	3	15. Front Side and User Elements	13
2. Product Description.....	3	16. Terminals and Wiring.....	14
3. Installation Requirements.....	4	17. Output Wire Sizes.....	14
4. Input	5	18. EMC	15
5. Outputs	5	19. Environment	16
6. Current Limitation and Tripping Behavior.....	6	20. Protection Features	17
7. Turning-on of Capacitive Loads.....	7	21. Dielectric Strength.....	17
8. Output-OK Relay Contact	10	22. Approvals.....	18
9. ON/OFF and Reset Signal Input	10	23. Fulfilled Standards.....	18
10. Synchronization of Multiple PISA Modules	10	24. Used Substances	18
11. Functional Diagram.....	11	25. Physical Dimensions and Weight.....	19
12. Back-feeding Loads	11	26. Accessory.....	19
13. Power Losses.....	12	27. Various Measurement Results.....	20
14. Reliability.....	12		

The information presented in this document is believed to be accurate and reliable and may change without notice.

The housing is patent by PULS (US patent No US D442,923S).

No part of this document may be reproduced or utilized in any form without permission in writing from the publisher (PULS GmbH). This also applies to all kinds of electronic publishing.

TERMINOLOGY AND ABBREVIATIONS

DC 24V

A figure displayed with the AC or DC before the value represents a nominal voltage with standard tolerances (usually $\pm 15\%$) included.

E.g.: DC 12V describes a 12V battery disregarding whether it is full (13.7V) or flat (10V)

24Vdc

A figure with the unit (Vac) at the end is a momentary figure without any additional tolerances included.

1. INTENDED USE

This device is designed for installation in an enclosure and is intended for the general use such as in industrial control, office, communication, and instrumentation equipment.

Do not use this power supply in aircraft, trains, nuclear equipment or similar systems where malfunction may cause severe personal injury or threaten human life.

This device is designed for use in non-hazardous, ordinary or unclassified locations.

2. PRODUCT DESCRIPTION

This protection module fulfills two basic functions. First it distributes the current of a large power source to four lower current output channels and therefore allows for smaller wires to be used. The second function is to permit only so much current on the outputs that the input voltage of this unit (which corresponds to the output voltage of the power supply) does not fall below 21V typically. This ensures a reliable supply voltage for sensitive equipments, such as PLCs, controls or sensors, when they are connected directly to the same power supply as the PISA protection module.

The protection module has one 24V input and four output channels to which the current is distributed. Each output channel is equipped with a protection circuit. The current of each individual channel is measured in order to achieve an electronic switch-off of the output before the supply voltage drops.

All four output channels will be current limited or switch-off simultaneously if the current of one individual channel or the maximum allowed current for the protection module is exceeded.

In case the input voltage would fall below 21V typically (e.g. due to overloads, too small of a power supply or high inrush currents such as from starting a motor), all four output channels will be actively current limited in order to avoid a drop of the power supply voltage below 21V. After a certain period of time in current limiting mode, all four outputs will be switched-off.

A typical wiring configuration is shown below. All sensitive loads are connected directly to the power supply. If needed, these load circuits can be protected with standard circuit breakers or fuses. Loads which are less sensitive to voltage dips or interruptions or which are the source of the voltage drop themselves are connected to the output of the PISA protection module.

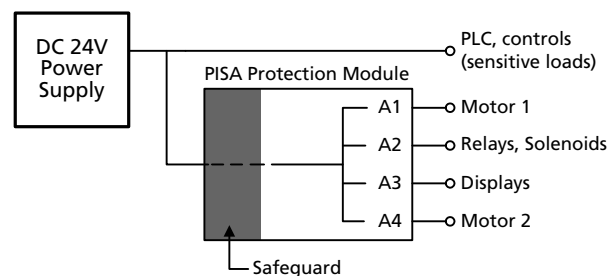

3. INSTALLATION REQUIREMENTS

This protection module is suitable for DIN-rail mounting. Use DIN-Rails according to EN 60715 or EN 50022 with a height of 7.5 or 15mm and can be used with any regulated 24Vdc power supply. If the power source can deliver more than 40A continuous, the PISA module shall be equipped with an external input fuse (e.g. 30/32A). The power capability and performance of the power supply can limit the output characteristics of the PISA module.

Make sure that the input voltage polarity is correct before applying the input voltage.

Do not connect batteries to the outputs of the PISA10 module.

This device may only be installed and put into operation by qualified personnel.

The unit does not contain serviceable parts. The tripping of an internal fuse is caused by an internal defect.

If damage or malfunction should occur during operation, immediately turn power off and send unit to the factory for inspection.

This device is designed for convection cooling and does not require an external fan. Do not obstruct airflow and do not cover ventilation grid.

The standard mounting orientation is input terminals on the bottom and output terminals on the top. Do not use the unit in other mounting orientations.

Keep the following installation clearances:

40mm on top, 20mm on the bottom

Left / right: 0mm (or 15mm in case the adjacent device is a heat source; in example another power supply....).

A high voltage drop between the power supply and the protection module might cause a malfunction. It is not recommended to use wires longer than 2x2m (for 2.5mm² or AWG14 wires) or 2x4m (for 4mm² or AWG12 wires) to avoid undesired undervoltage conditions on the input of the protection module.

Fig. 3-1 **Wiring scheme**

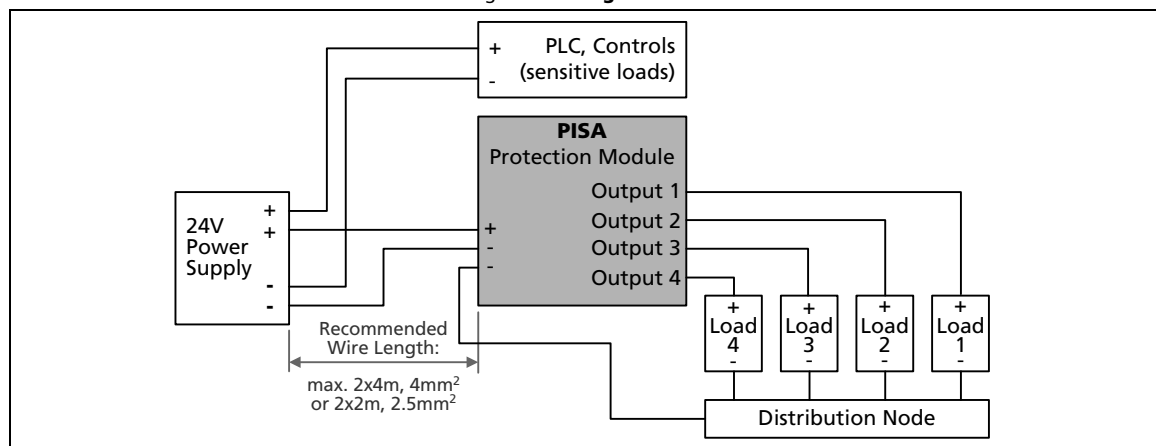

⚠ WARNING

Risk of electrical shock, fire, personal injury or death.

- Turn power off before working on the device. Protect against inadvertent re-powering.
- Make sure that the wiring is correct by following all local and national codes.
- Do not modify or repair the unit.
- Do not open the unit.
- Use caution to prevent any foreign objects from entering the housing.
- Do not use in wet locations or in areas where moisture or condensation can be expected.

4. INPUT

Input voltage	nom.	DC 24V	±25%
Input voltage range	-	18Vdc – 30Vdc	Absolute maximum continuous input voltage with no damage to the PISA module
	max.	35Vdc	
Required input voltage for turning-on of outputs	typ.	21.4Vdc	
Turn-on delay of outputs	typ.	270ms	Period between applying the input voltage and turning on the outputs. All outputs will be turned-on at the same time.
Input voltage protection level	min.	20.7Vdc	Below this voltage level, outputs will be switched-off
	max.	22.1Vdc	
Stand-by input current	typ.	46mA	Stand-by current when all outputs are turned-on

5. OUTPUTS

			PISA10.401	PISA10.402	PISA10.403	PISA10.404
Output current	output 1	nom.	1A	2A	3A	4A
	output 2	nom.	1A	2A	3A	4A
	output 3	nom.	1A	2A	3A	4A
	output 4	nom.	1A	2A	3A	4A
All 4 outputs together		nom.	4A	8A	12A	16A
Output current limitation *)		min.	13A	13A	21A	21A
		typ.	15A	15A	25A	25A
		max.	18A	18A	30A	30A
Voltage drop **)	per output	typ.	80mV	110mV	100mV	110mV
Integrated fuse	per output		2A	3A	4A	5A

			PISA10.406	PISA10.410	PISA10.203206	PISA10.206210
Output current	output 1	nom.	6A	10A ^{***)}	3A	6A
	output 2	nom.	6A	10A ^{***)}	3A	6A
	output 3	nom.	6A	10A ^{***)}	6A	10A ^{***)}
	output 4	nom.	6A	10A ^{***)}	6A	10A ^{***)}
All 4 outputs together		nom.	20A	20A	18A	20A
Output current limitation *)		min.	21A	21A	21A	21A
		typ.	25A	25A	25A	25A
		max.	30A	30A	30A	30A
Voltage drop **)	output 1, 2	typ.	150mV	210mV	120mV	170mV
	output 3, 4	typ.	150mV	210mV	130mV	185mV
Integrated fuse	output 1, 2		7.5A	15A	4A	7.5A
	output 3, 4		7.5A	15A	7.5A	15A

*) The current limitation value for the sum of all four output currents. This current can be drawn from each individual output regardless whether it is a 1A, 2A, 3A, 4A, 6A or 10A output. According to the specified ampacity of the outputs, the current can flow for a shorter or longer period before the protection module switch off all four outputs at the same time. Tripping times can be found in chapter 6.

***) Voltage loss between input and output, when all output channels are loaded with 50% of its nominal current.

***) A current de-ratig can be required for temperatures above +45°C. See also chapter 19.

6. CURRENT LIMITATION AND TRIPPING BEHAVIOR

The PISA10 protection module comprises one common limitation and switching element for all four outputs. In a protection case, all four outputs limit the current or switch off at the same time.

The following reasons can cause a limitation of the output currents or a shut-off of the output channels:

- 1) The output current of one or more individual output channels was too high.
- 2) The sum of the output current of all four output channels was exceeded.
- 3) The outputs needed to be switched-off in order to maintain sufficient input voltage.

Tripping behavior*) for a too high output current of one individual output channel:

			PISA10.401 (4x1A)	PISA10.402 (4x2A)	PISA10.403 (4x3A)	PISA10.404 (4x4A)
0.5A Overload	per output	typ.	0.1s at 1.5A	0.4s at 2.5A	--	--
1.0A Overload	per output	typ.	--	--	0.17s at 4A	0.3s at 5A
2x Rated current	per output	typ.	0.05s at 2A	0.1s at 4A	0.06s at 6A	0.07s at 8A
Short circuit	per output	max.	18A for typ. 3ms	18A for typ. 12ms	30A for typ. 8ms	30A for typ. 10ms

			PISA10.406 (4x6A)	PISA10.410 (4x10A)	PISA10.203206 (2x3A, 2x6A)	PISA10.206210 (2x6A, 2x10A)
1.0A Overload	output 1, 2	typ.	0.7s at 7A	1.7s at 11A	0.17s at 4A	0.7s at 7A
	output 3, 4	typ.	0.7s at 7A	1.7s at 11A	0.7s at 7A	1.7s at 11A
2x Rated current	output 1, 2	typ.	0.1s at 12A	0.17s at 20A	0.06s at 6A	0.1s at 12A
	output 3, 4	typ.	0.1s at 12A	0.17s at 20A	0.1s at 12A	0.17s at 20A
Short circuit	output 1, 2	max.	30A for typ. 30ms	30A for typ. 90ms	30A for typ. 8ms	30A for typ. 30ms
	output 3, 4	max.	30A for typ. 30ms	30A for typ. 90ms	30A for typ. 30ms	30A for typ. 90ms

*) The timer for the tripping time starts immediately once the nominal current levels are exceeded. All output channels will switch-off, if one channel is overloaded. See Fig. 6-1 for more values.
A switch-off of the outputs can also happen earlier, e.g. when the PISA module has to protect the supply voltage in case the power supply can not deliver enough current to support all loads without going into overload.

Fig. 6-1 Tripping characteristic for 1A, 2A, 3A, 4A, 6A and 10A output channels

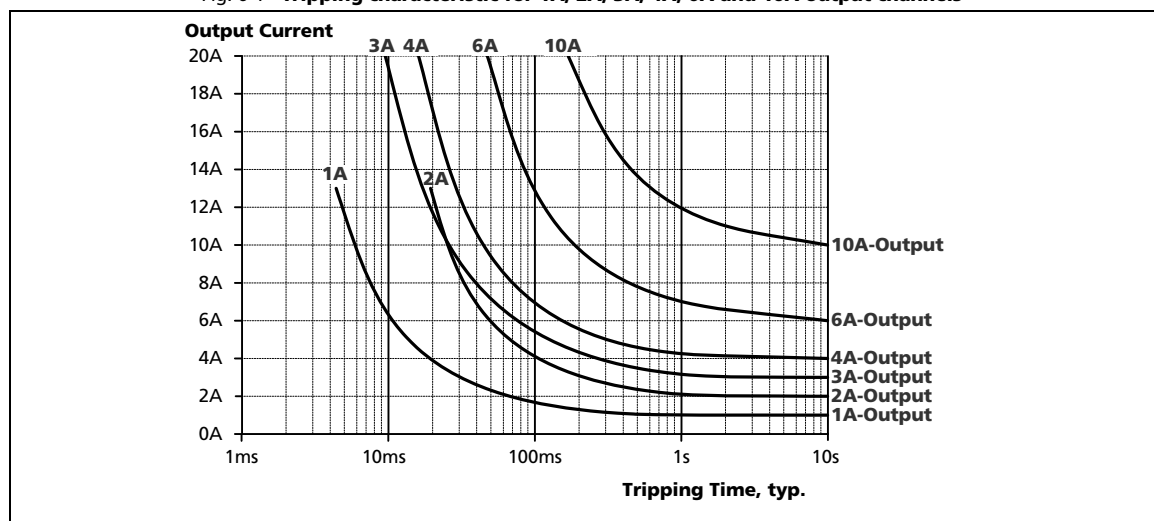

Tripping behavior to avoid under-voltage situations on the supply voltage

A further limitation of the output current activates when the supplying power source can not deliver enough current to support all loads without bringing the power source into overload followed by a voltage drop. In such a case, the voltage dependent current limitation of the input stage of the protection module is activated (safeguard circuit). This safeguard circuit acts like a valve only permitting so much current so that the supply voltage does not fall below 21V. The period of time for how long the protection circuit is able to actively limit the current depends on the difference between input and output voltage and the current which flows through the PISA protection module. After this period, all outputs will be switched off. Tripping times for a short circuit condition across the outputs can be found in Fig. 6-2.

Fig. 6-2 Active current limitation- Period of time in current limiting mode until the outputs will be switched off, typ.

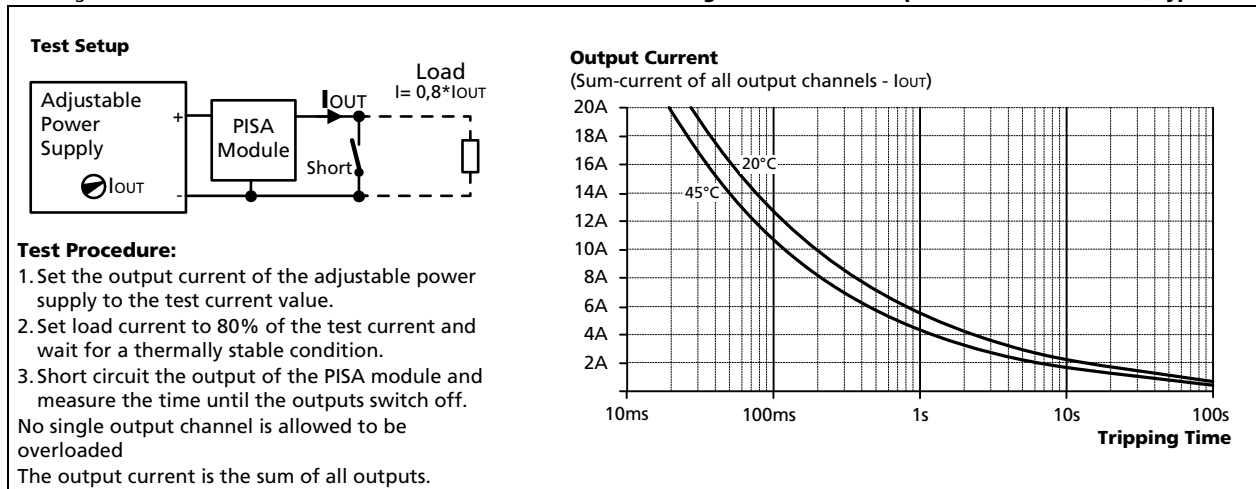

7. TURNING-ON OF CAPACITIVE LOADS

Large input capacitors of drives, monitors or other similar loads can result in an unintended switching-off of the module when trying to turn-on such loads. This especially can occur after a reset or by turning on a load via the push button or the external signal input. The PISA protection module is designed to be exceptionally compatible with such types of loads. The module turn-on as much capacitance as possible and comprises several different protection mechanisms to protect against an unintended switching-off or damage of the unit.

The permissible capacitor sizes which can be turned-on depend on the load current itself as well as on the characteristic of the load. If the load characteristic is not known, it is recommended to choose the curves for constant current loads.

a) Permissible load capacitance per module (four outputs)

The tables below show the permissible capacitors, which can be switched-on on the outputs without switching-off of the protection module. The listed values are valid for the entire temperature range.

The minimal values are worst-case figures and are defined with an additional constant current load with the maximum permissible total current of the PISA protection module. See also Fig. 7-1.

The typical values are defined with an additional resistive load. See also Fig. 7-1.

Total capacitance per module		PISA10.401 (4x1A)	PISA10.402 (4x2A)	PISA10.403 (4x3A)	PISA10.404 (4x4A)
All four outputs together	typ.	16mF	56mF	48mF	76mF
	min.	12mF	20mF	30mF	20mF

Total capacitance per module		PISA10.406 (4x6A)	PISA10.410 (4x10A)	PISA10.203206 (2x3A, 2x6A)	PISA10.206210 (2x6A, 2x10A)
All four outputs together	typ.	90mF	26mF	90mF	85mF
	min.	16mF	16mF	16mF	16mF

	Parameters for typical values
PISA10.401	0.5A resistive load per output
PISA10.402	1A resistive load per output
PISA10.403	1.5A resistive load per output
PISA10.404	2A resistive load per output
PISA10.406	3A resistive load per output
PISA10.410	5A resistive load per output
PISA10.203206	1.5A resistive load for outputs 1 & 2 3A resistive load for outputs 3 & 4
PISA10.206210	3A resistive load for outputs 1 & 2 5A resistive load for outputs 3 & 4

	Parameters for minimum values
PISA10.401	1A constant current load per output
PISA10.402	2A constant current load per output
PISA10.403	3A constant current load per output
PISA10.404	4A constant current load per output
PISA10.406	5A constant current load per output
PISA10.410	5A constant current load per output
PISA10.203206	3A constant current load for outputs 1 & 2 6A constant current load for outputs 3 & 4
PISA10.206210	5A constant current load for outputs 1 & 2 5A constant current load for outputs 3 & 4

Fig. 7-1 Permissible load capacitance per module (four outputs) at 24V

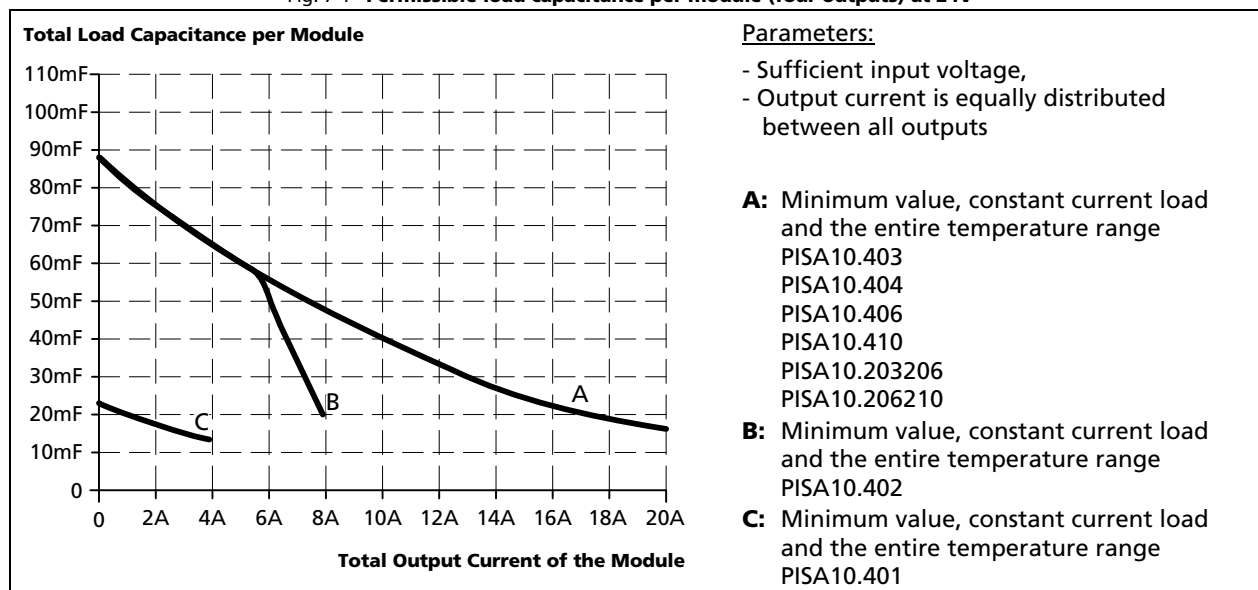

b) Permissible load capacitance of the individual output channels

The tables below show the permissible capacitors, which can be switched-on for one particular output when only this output is loaded and all others are not. The listed values are valid for the entire temperature range.

The minimum values are defined with an additional constant current load according to the parameter list below. During the tests, only one output is loaded and all others are not. See also Fig. 7-2.

The typical values are defined with an additional resistive load according to the parameter list below. During the tests, only one output is loaded and all others are not. See also Fig. 7-2.

		PISA10.401 (4x1A)	PISA10.402 (4x2A)	PISA10.403 (4x3A)	PISA10.404 (4x4A)
Capacitance per output channel	typ.	4mF	14mF	12mF	19mF
	min.	3mF	10mF	8mF	13mF

		PISA10.406 (4x6A)	PISA10.410 (4x10A)	PISA10.203206 (2x3A, 2x6A)	PISA10.206210 (2x6A, 2x10A)
Capacitance for channel 1 & 2	typ.	42mF	90mF	12mF	42mF
	min.	30mF	50mF	8mF	30mF
Capacitance for channel 3 & 4	typ.	42mF	90mF	42mF	90mF
	min.	30mF	50mF	30mF	50mF

Parameters for typical values

- PISA10.401 with additional 0.5A resistive load
- PISA10.402 with additional 1A resistive load
- PISA10.403 with additional 1.5A resistive load
- PISA10.404 with additional 2A resistive load
- PISA10.406 with additional 3A resistive load
- PISA10.410 with additional 5A resistive load
- PISA10.203206 3A: with additional 1.5A resistive load
6A: with additional 3A resistive load
- PISA10.206210 6A: with additional 3A resistive load
10A: with additional 5A resistive load

Parameters for minimum values

- with additional 1A constant current load
- with additional 2A constant current load
- with additional 3A constant current load
- with additional 4A constant current load
- with additional 6A constant current load
- with additional 10A constant current load
- with additional 3A constant current load
- with additional 6A constant current load
- with additional 10A constant current load

Fig. 7-2 Permissible load capacitance per output channel at 24V, typ.

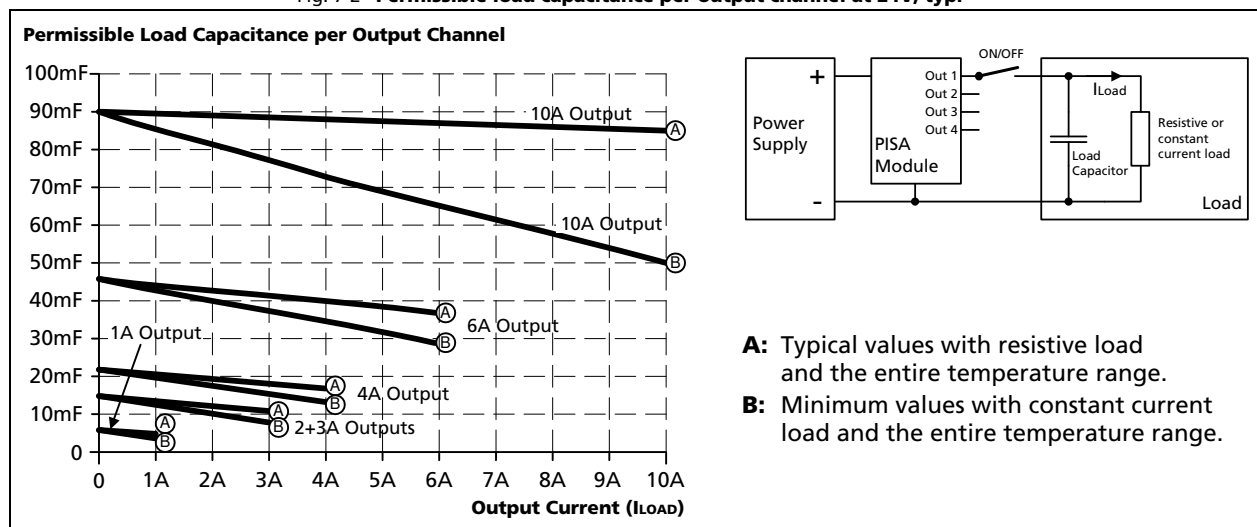

- A:** Typical values with resistive load and the entire temperature range.
- B:** Minimum values with constant current load and the entire temperature range.

8. OUTPUT-OK RELAY CONTACT

This relay contact is closed when the input voltage is sufficient and the outputs are not switched off.

Threshold voltage	typ.	21.4Vdc	Required voltage to power the relay and to close the relay contact. Additionally, the outputs must not be switched off.
Contact ratings	max.	30Vdc, 1.0A	Resistive load
	max.	30Vac, 0.5A	Resistive load
	min.	1mA at 5Vdc	
Galvanic isolation	nom.	500Vac	Test voltage: Signal path to power path

9. ON/OFF AND RESET SIGNAL INPUT

This signal input is galvanically isolated with an integrated optocoupler and works in the same manner as the reset and ON/OFF button.

In a failure mode (outputs have switched-off), the outputs can be turned on again by applying a voltage for more than 1 second.

In normal mode (outputs have not switched-off), a short (> 50ms) voltage pulse will turn all outputs ON or OFF.

The unit will be shipped (factory setting) with the outputs turned-on.

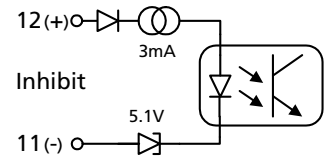

Signal voltage	max.	30Vdc	
Signal current	typ.	3mA	Active current limited
	max.	6mA	active current limited
Threshold voltage levels	min	6Vdc	Voltages above this level will trigger the inhibit or reset.
	max.	10Vdc	
Galvanic isolation	nom.	500Vac	Test voltage: signal path to power path

10. SYNCHRONIZATION OF MULTIPLE PISA MODULES

If multiple PISA modules are used on the same power supply, it is recommended to connect the sync. bus of all modules together. If one unit switches-off due to the protection function of the input voltage protection circuit (safeguard), all other modules will be switched off too. This avoids a false interpretation of which output channel caused the problem. If the sync. buses are not linked, the module with the highest safeguard protection voltage would switch off first regardless whether the failure was caused by this module or not.

Please note:
If the cause for the switch-off was an over-current of one individual channel only this module will switch off and the other modules will stay on. In this case the sync. line has no impact on the other modules.

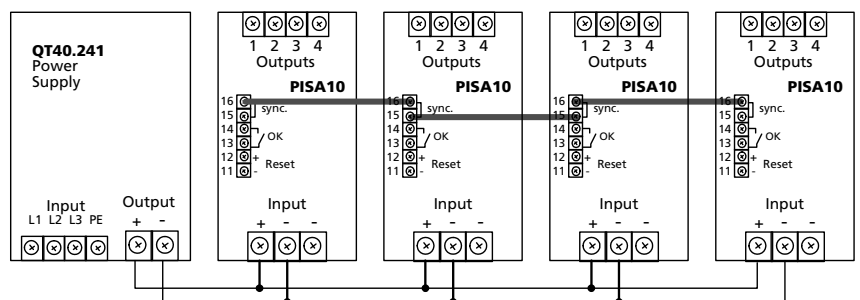

11. FUNCTIONAL DIAGRAM

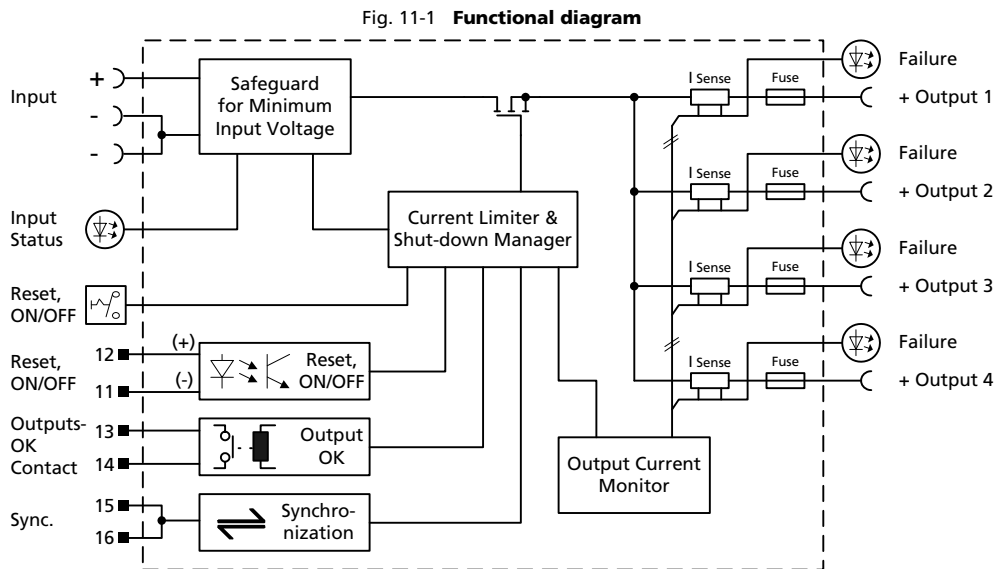

12. BACK-FEEDING LOADS

Loads such as decelerating motors and inductors can feed voltage back to the PISA10 protection module. This feature is also called return voltage immunity or resistance against Back- E.M.F. (Electro Magnetic Force). The protection module is resistant and does not show malfunctioning when a load feeds back voltage up to 35Vdc to the protection module. It does not matter whether the protection module is on or off. The protection module has no capability to absorb energy. Internal diodes direct the voltage and energy to the power supply, which is connected on the input side of the protection module. The power supply defines the amount of energy which can be absorbed.

13. POWER LOSSES

		PISA10.401	PISA10.402	PISA10.403	PISA10.404
No-load losses	typ.	1.1W	1.1W	1.1W	1.1W
Losses at typical output loads ^{*)}	typ.	1.2W	1.6W	1.9W	2.4W

		PISA10.406	PISA10.410	PISA10.203206	PISA10.206210
No-load losses	typ.	1.1W	1.1W	1.1W	1.1W
Losses at typical output loads ^{*)}	typ.	3.0W	5.5W	2.3W	4.2W

*) Typical value when all output channels are loaded with 50% of its nominal current.

14. RELIABILITY

The PISA protection modules are extremely reliable and use only the highest quality materials. The number of critical components such as electrolytic capacitors have been reduced.

	PISA10.401	PISA10.402	PISA10.403	PISA10.404	
Applied load	4x0.5A	4x1A	4x1.5A	4x2A	
Lifetime expectancy *)	T.B.D.	T.B.D.	T.B.D.	T.B.D.	at 40°C
	T.B.D.	T.B.D.	T.B.D.	T.B.D.	at 25°C
MTBF **) SN 29500, IEC 61709	T.B.D.	T.B.D.	T.B.D.	T.B.D.	at 40°C
	T.B.D.	T.B.D.	T.B.D.	T.B.D.	at 25°C
MTBF **) MIL HDBK 217F, GB	T.B.D.	T.B.D.	T.B.D.	T.B.D.	at 40°C
	T.B.D.	T.B.D.	T.B.D.	T.B.D.	at 25°C

	PISA10.406	PISA10.410	PISA10.203206	PISA10.206210	
Applied load	4x3A	4x5A	2x1.5A + 2x3A	2x3A + 2x5A	
Lifetime expectancy *)	T.B.D.	T.B.D.	T.B.D.	T.B.D.	at 40°C
	T.B.D.	T.B.D.	T.B.D.	T.B.D.	at 25°C
MTBF **) SN 29500, IEC 61709	T.B.D.	T.B.D.	T.B.D.	T.B.D.	at 40°C
	T.B.D.	T.B.D.	T.B.D.	T.B.D.	at 25°C
MTBF **) MIL HDBK 217F, GB	T.B.D.	T.B.D.	T.B.D.	T.B.D.	at 40°C
	T.B.D.	T.B.D.	T.B.D.	T.B.D.	at 25°C

*) The Lifetime expectancy shown in the table indicates the minimum operating hours (service life) and is determined by the lifetime expectancy of the built-in electrolytic capacitors. Lifetime expectancy is specified in operational hours and is calculated according to the capacitor's manufacturer specification. The manufacturer of the electrolytic capacitors only guarantees a maximum life of up to 15 years (131 400h). Any number exceeding this value is a calculated theoretical lifetime which can be used to compare devices.

) **MTBF stands for **Mean Time Between Failure**, which is calculated according to statistical device failures, and indicates reliability of a device. It is the statistical representation of the likelihood of a unit to fail and does not necessarily represent the life of a product.

The MTBF figure is a statistical representation of the likelihood of a device to fail. A MTBF figure of e.g. 1 000 000h means that statistically one unit will fail every 100 hours if 10 000 units are installed in the field. However, it can not be determined if the failed unit has been running for 50 000h or only for 100h.

15. FRONT SIDE AND USER ELEMENTS

A Output Terminals (plus (+) pole connection points)

B Red Failure LEDs

The red LEDs are failure indicators. Any time a red LED is on or blinking, the outputs have been switched OFF.

Three reasons why the outputs have been switched OFF:

- 1) The output current of one or more individual output channels was too high. In this case, the affected output channel LED is blinking and all others are illuminated.
- 2) The sum of the output current of all four output channels was exceeded. In this case, all red LEDs are blinking.
- 3) The outputs needed to be switched off in order to maintain sufficient input voltage. In this case, all red LEDs are on and the green LED is blinking.

The outputs can also be turned off by pushing the ON/OFF button on the front of the unit or by applying an external signal to the ON/OFF signal input. In this case, all red LEDs are on.

When LED 1 and 4 as well as the LEDs 2 and 3 are alternately blinking, an internal error occurred and the unit needs to be shipped to the factory for inspection.

C ON/OFF and Reset Button

This is a pushbutton which can be used for two purposes:

- 1) In a failure mode (outputs have switched-off), the outputs can be turned on again by pushing and holding the reset button for more than 1 second.
 - 2) In normal mode (outputs have not switched-off), a short (> 50ms) push will turn all outputs ON or OFF.
- The unit will be shipped (factory setting) with the outputs turned-on.

D Synchronization Bus (connection by plug-connector on the front), See also chapter 10.

If multiple PISA modules are used on the same power supply, it is recommended to connect the sync. bus of all modules together. If one unit switches off due to the protection function of the input voltage protection circuit, all other modules will be switched off too. This avoids a false interpretation of which output channel caused the problem.

E Output-OK Relay Contact (connection by plug-connector on the front), See also chapter 8.

This relay contact is closed when the input voltage is sufficient and all outputs are not switched off.

F Inhibit / Reset Signal Input (connection by plug-connector on the front), See also chapter 9.

This signal input is galvanically isolated with an integrated optocoupler and works in the same manner as the reset and ON/OFF button.

- In a failure mode (outputs have switched off), the outputs can be turned on again by applying a voltage for more than 1 second.
- In normal mode (outputs have not switched off), a short (> 50ms) voltage pulse will turn all outputs ON or OFF.

G Green Input Status LED

This LED monitors the input voltage. The green LED is illuminated if the input voltage is higher than 21Vdc typically. The green LED will blink when the input protection circuit (Safeguard) is activated in order to protect the supply voltage from dropping below 21V or when the outputs have already been switched off due to a low input voltage.

H Input Terminals

Two minus (-) connection points for simpler load distribution or grounding (earthing) of the minus (-) pole.

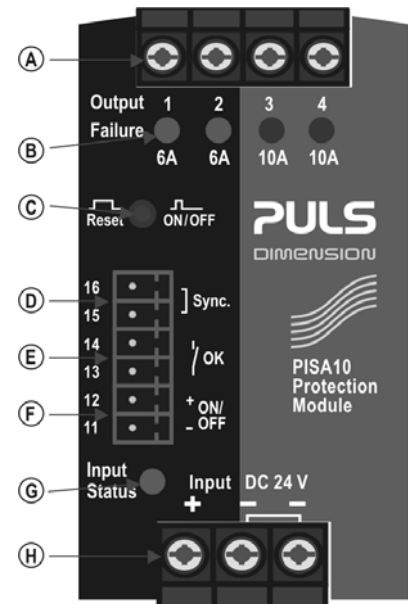

Please note:

Outputs which have switched off must be turned on manually by pushing the reset button or by an external reset signal (ON/OFF signal input). A cycling of the input power does not reset the unit. The failure signals are stored until a reset is intentionally initiated.

16. TERMINALS AND WIRING

All terminals are easy to access when mounted on the panel.

Input, outputs- and signal terminals are separated from each other to help in error-free wiring.

	Input and Output	Signals
Type	screw terminals	plug connector
Solid wire	0.5-6mm ²	0.2-1.5mm ²
Stranded wire	0.5-4mm ²	0.2-1.5mm ²
AWG (American Wire Gauge)	20-10 AWG	24-16 AWG
Wire stripping length	7mm / 0.28inch	6mm / 0.24inch
Screwdriver	3.5mm slotted or Pozidrive No 2	2.5mm slotted
Recommended tightening torque	0.8Nm, 7lbs.in	0.35Nm, 3lbs.in

Instructions:

- a) Use appropriate copper cables that are designed for an operating temperature of: 60°C for ambient up to 45°C and 75°C for ambient up to 60°C minimum.
- b) Follow national installation codes and installation regulations!
- c) Ensure that all strands of a stranded wire enter the terminal connection!
- d) Up to two stranded wires with the same cross section are permitted in one connection point.
- e) Screws of unused terminal compartments should be securely tightened.
- f) Ferrules are allowed.

17. OUTPUT WIRE SIZES

One task of the PISA module is the distribution of the current from a large amparage power supply to four current monitored output channels. This permits wires with smaller cross-sections than would be needed for the ampacity of the power supply.

Every output channel on the PISA module is equipped with an internal soldered-in lead fuse. This fuse conforms to UL248. Therefore, the requirements for Branch Circuit Protection in accordance with UL508A section 31.1.2 are fulfilled. The current of each individual channel is measured in order to achieve an electronic switch off of the output before the lead fuse opens.

For the coordination between wire sizes and load currents, the relevant regulations must be observed. In most cases, these are VDE 0891, VDE 0100-523 and the IEC/EN 60204-1. This means that the following wire sizes shall be used in typical applications:

1A output:	≥0,14mm ²	(approximately equals AWG26)
2A output:	≥0,25mm ²	(approximately equals AWG24)
3A output:	≥0,34mm ²	(approximately equals AWG22)
4A output:	≥0,50mm ²	(approximately equals AWG20)
6A output:	≥0,75mm ²	(approximately equals AWG18)
10A output:	≥1,0mm ²	(approximately equals AWG16)

18. EMC

The PISA protection module is suitable for applications in industrial environment as well as in residential, commercial and light industrial environments without any restrictions (e-g- cable length). The CE mark indicates conformance with EMC guideline 2004/108/EC and the low-voltage directive (LVD) 2006/95/EC. A detailed EMC report is available on request.

EMC Immunity

Generic standards: EN 61000-6-1 and EN 61000-6-2

			Outputs ON	Outputs OFF	
Electrostatic discharge	EN 61000-4-2	Contact discharge Air discharge	8kV	8kV	Criterion A
Electromagnetic RF field	EN 61000-4-3	80MHz-2,7GHz	10V/m	10V/m	Criterion A
Fast transients (Burst)	EN 61000-4-4	Input lines	2kV	2kV	Criterion A
		output lines	2kV	2kV	Criterion A
		DC-OK, Inhibit	1kV	1kV	Criterion A
Surge voltage on input lines	EN 61000-4-5	+ → -	500V	500V	Criterion A
		+/- → DIN-Rail	1kV	1kV	Criterion A
Surge voltage on output lines	EN 61000-4-5	+ → -	500V	500V	Criterion A
		+/- → DIN-Rail	1kV	1kV	Criterion A
Surge voltage on signal lines	EN 61000-4-5	DC-OK, Inhibit → DIN-Rail	1kV	1kV	Criterion A
Conducted disturbance	EN 61000-4-6	0.15-80MHz	10V	10V	Criterion A

Criterion A: The PISA protection module shows normal operation behavior within the defined limits.

EMC Emissions

Generic standards: EN 61000-6-3 und EN 61000-6-4

Conducted emission	IEC/CISPR 16-1-2, IEC/CISPR 16-2-1			Class B, DC input and DC-output
Radiated emission	EN 55011, EN 55022			Class B
FCC	This device complies with FCC Part 15 rules. Operation is subjected to the following two conditions: (1) this device may not cause harmful interference and (2) this device must accept any interference received, including interference that may cause undesired operation.			

19. ENVIRONMENT

Operational temperature *) -25°C to +60°C (-13°F to 140°F)

Note: De-rating requirements for PISA10.410 and PISA10.206210 in regards to the max. current of the 10A output channels at ambient temperatures above +45°C. See also Fig. 19-2 and Fig. 19-3.

Storage temperature -40 to +85°C (-40°F to 185°F)

Humidity **) 5 to 95% r.H. IEC 60068-2-30

Vibration sinusoidal 2-17.8Hz: ±1.6mm; 17.8-500Hz: 2g IEC 60068-2-6
2 hours / axis

Shock 30g 6ms, 20g 11ms IEC 60068-2-27
3 bumps / direction, 18 bumps in total

Altitude 0 to 6000m (0 to 20 000ft)

Over-voltage category III IEC 62103, EN 50178, altitudes up to 2000m
II for altitudes from 2000m to 6000m

Degree of pollution 2 IEC 62103, EN 50178, not conductive

*) Operational temperature is the same as the ambient temperature and is defined as the air temperature 2cm below the unit.

**) Do not energize while condensation is present.

Fig. 19-1 **Total module output current vs. ambient temperature**

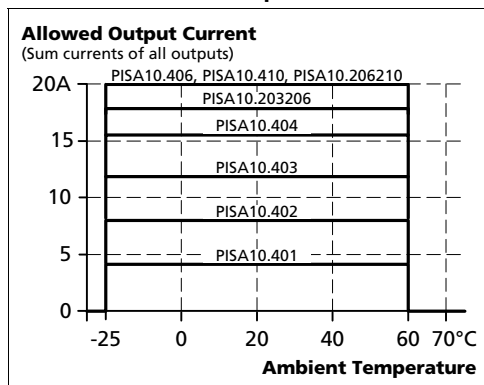

Fig. 19-2 **De-rating PISA10.206210**

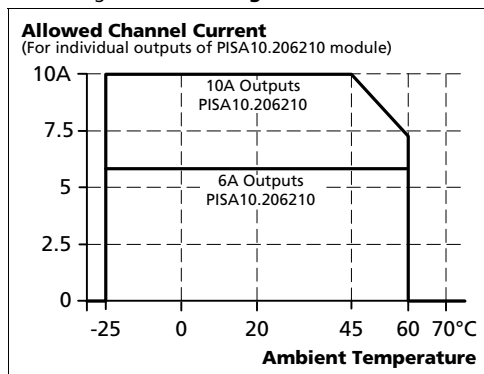
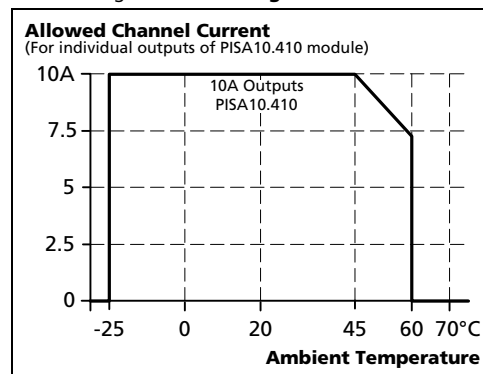

Fig. 19-3 **De-rating PISA10.410**



20. PROTECTION FEATURES

Output over-current protection	Electronically limited	
Class of protection	III	IEC 61140
Degree of protection	IP 20	EN/IEC 60529
Penetration protection	> 2.5mm in diameter	E.g. screws, small parts
Over-temperature protection	Not included	
Reverse polarity protection; input voltage	Not included	Make sure that the input voltage polarity is correct before applying the input voltage.
Internal input fuse	Not included	

21. DIELECTRIC STRENGTH

The relay contact and the ON/OFF signal input are floating and have no ohmic connection to the input or output voltage. Type and factory tests are conducted by the manufacturer.

The creepage and clearance distances between relay contacts, the ON/OFF signal input and input/output voltage are 1.3mm.

The following dielectric strength tests were conducted:

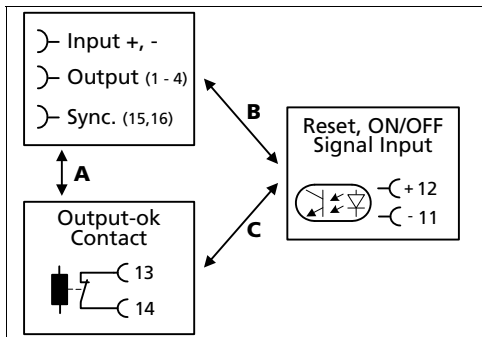

Fig. 21-1 Dielectric strength



		A	B	C
Type test	60s	500Vac	500Vac	50Vac
Factory test	5s	500Vac	500Vac	-
Field test	5s	500Vac	500Vac	50Vac
Cut-off current setting		> 1mA	> 1mA	> 1mA

Type and factory tests are conducted by the manufacturer. Field tests may be conducted in the field using the appropriate test equipment which applies the voltage with a slow ramp (2s up and 2s down). Connect all input and output terminals together as well as all signal poles before conducting the tests. When testing, set the cut-off current settings to the value in the table above.

22. APPROVALS

EC Declaration of Conformity		The CE mark indicates conformance with EMC directive 2004/108/EC and the low-voltage directive (LVD) 2006/95/EC.
IEC 60950-1 pending		CB Scheme, Safety of Information Technology Equipment
UL 508 pending		Listed for the use as Industrial Control Equipment; U.S.A. (UL 508) and Canada (C22.2 No. 107-1-01); E-File: E198865
UL 60950-1 pending		Recognized for the use as Information Technology Equipment", Level 5; U.S.A. (UL 60950-1) and Canada (C22.2 No. 60950); E-File: E137006
Marine planed		GL (Germanischer Lloyd) classified Environmental category: C, EMC2 Marine and Offshore applications
GOST P planed		Certificate of Conformity for Russia and other GUS countries

23. FULFILLED STANDARDS

EN/IEC 60204-1	Safety of Electrical Equipment of Machines
EN/IEC 61131-2	Programmable Controllers
EN 50178, IEC 62103	Electronic Equipment in Power Installations

24. USED SUBSTANCES

The unit does not release any silicone and is suitable for the use in paint shops.

The unit conforms to the RoHS directive 2002/96/EC.

Electrolytic capacitors included in this unit do not use electrolytes such as Quaternary Ammonium Salt Systems.

Plastic housings and other molded plastic materials are free of halogens, wires and cables are not PVC insulated.

Wires and cables are not PVC isolated

The production material within our production does not include following toxic chemicals:
 Polychlorized Biphenyl (PCB), Polychlorized Terphenyl (PCT), Pentachlorophenol (PCP), Polychlorinated naphthalene (PCN), Polybrom Biphenyl (PBB), Polybrom Biphenyl-oxyd (PBO), Polybrominated Diphenylether (PBDE), Polychlorinated Diphenylether (PCDE), Polydibromphenyl Oxyd (PBDO), Cadmium, Asbestos, Mercury, Silicia.

25. PHYSICAL DIMENSIONS AND WEIGHT

Weight	140g / 0.31lb
DIN-Rail	Use 35mm DIN-rail according to EN 60715 or EN 50022 with a height of 7.5 or 15mm. The DIN-rail height must be added to the unit depth to calculate the total required installation depth.
Installation clearances	See chapter 3

Fig. 25-1 **Front view**

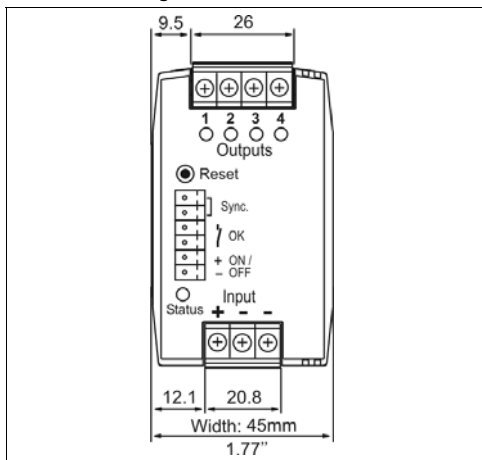
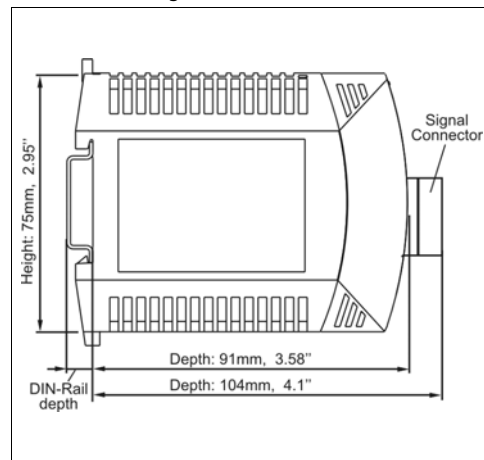

Fig. 25-2 **Side view**



26. ACCESSORY

DIN-Rail bracket for wall or panel mount:

A suitable DIN-rail bracket is available on request.

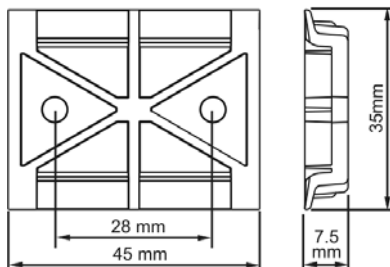

Note: The picture is for representation only.

27. VARIOUS MEASUREMENT RESULTS

Test setup for the following measurements:

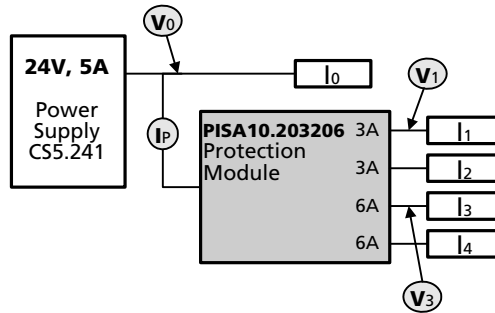

a) Short-circuit across a 6A output of a PISA10.203206 protection module

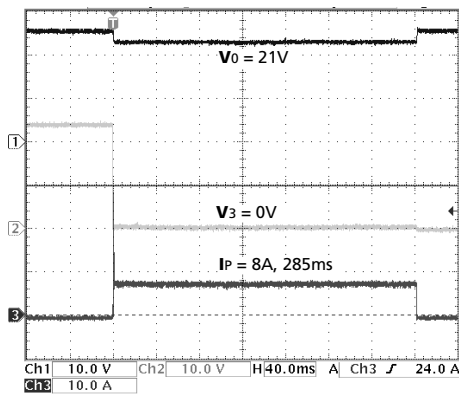

Parameters:
 Power supply: 5A (CS5.241)
 $I_0 = 0A$
 $I_3 = \text{Short-circuit}$
 $I_1, I_2, I_4 = 0A$

8A is flowing and is the current level that can be drawn from the CS5.241 power supply without the supply voltage falling below 21V. The electronic circuit in the PISA protection module can actively limit this current for 285ms. After this time period, the outputs will be switched-off in order to protect the internal lead fuse in the 6A output channel.

b) Short-circuit across a 3A output of a PISA10.203206 protection module

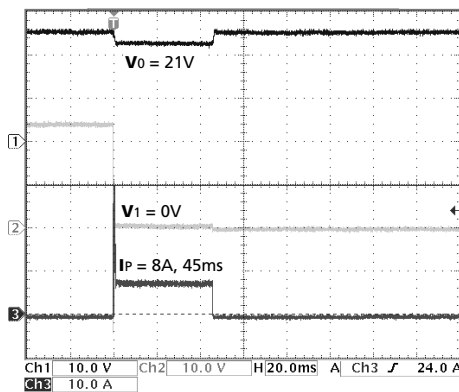

Parameters:
 Power supply: 5A (CS5.241)
 $I_0 = 0A$
 $I_1 = \text{Short circuit}$
 $I_2, I_3, I_4 = 0A$

Similar situation as in figure 8 but the tripping time is faster to protect the internal lead fuse in the 3A output.

The same 8A is flowing and this is the current level that can be drawn from the CS5.241 power supply without the supply voltage falling below 21V. The electronic circuit in the PISA protection module limits this current actively for 45ms. After this time period, the outputs will be switched-off in order to protect the internal lead fuse in the 3A output channel.

c) Both 6A outputs of a PISA10.203206 module loaded with 6A (4 Ohm resistive load)

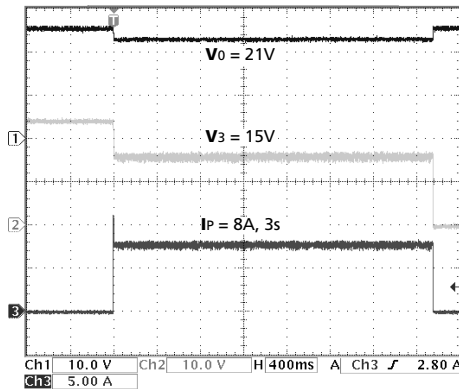

Parameters:
 Power supply: 5A (CS5.241)
 $I_0, I_1, I_2 = 0A$
 $I_3, I_4 = 6A (4\Omega)$

The power supply can not deliver the required current and switches into current limiting mode. The PISA module only permits so much current on the outputs so that the input voltage does not drop below 21V. With these conditions, there is only 15V on the outputs of the protection module.

The electronic circuit in the PISA protection module actively limits this current for 3s. After this period, the outputs will be switched-off in order to protect the MOSFET in the PISA module.

d) The power supply is directly loaded with 4A (6 Ohm resistive load) and one 6A output of a PISA10.203206 module is loaded with 6A (4 Ohm resistive load)

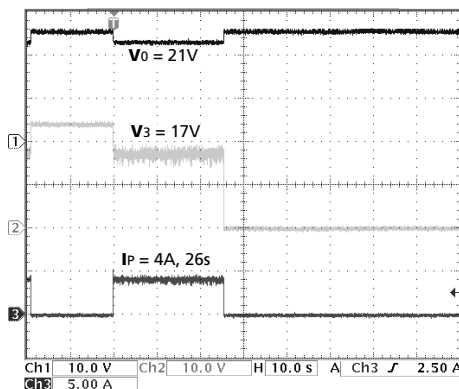

Parameters:
 Power supply: 5A (CS5.241)
 $I_0 = 4A (6\Omega)$
 $I_3 = 6A (4\Omega)$
 $I_1, I_2, I_4 = 0A$

The power supply can not deliver the required current and switches into current limiting mode. The PISA module only permits so much current on the outputs so that the input voltage does not drop below 21V. With these conditions, there is only 17V on the outputs of the protection module.

The electronic circuit in the PISA protection module limits this current actively for 26s. After this period, the outputs will be switched-off in order to protect the MOSFET in the PISA module.