



### PROTECTION MODULE

- One Input and Four Current Controlled Outputs
- Ensures Sufficient Supply Voltage for Critical Loads even in the Event of an Fault
- Protects Small Cable Sizes against Overload
- Hassle-free Turn-on of Loads with Large Input Capacitors
- NEC Class 2 Compliant (1A and 2A Model)
- Wide Temperature Range between -25°C and +70°C
- On/Off Function of Outputs
- Compact Design, Width only 45mm
- Remote Monitoring and Control Functions
- 3 Year Warranty

### GENERAL DESCRIPTION

This protection module fulfills two basic functions. First it distributes the current of a large power source to four lower current output channels and therefore allows for smaller wires to be used. The second function is to permit only so much current on the outputs that the input voltage of this unit (which corresponds to the output voltage of the power supply) does not fall below 21V.

This ensures a safe and an uninterrupted supply voltage for sensitive equipments, such as PLCs, controls or sensors, when they are connected directly to the same power supply as the PISA module. Less critical loads that are not affected to short voltage interruptions or that could even be the cause of a fault on the 24V power supply are connected to one of the four current controlled output channels of the PISA module.

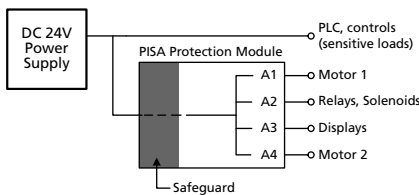

### SHORT-FORM DATA

Input voltage	DC 24V	
Input voltage range	18 - 30V	
Input current	typ. 43mA	At no load
Number of outputs	4	
Output currents	fixed between 1A and 12A	See order information
Input voltage protection levels	typ. 21.4V	
Temperature range	-25°C to +70°C	Operational
	-40°C to +85°C	Storage
Type of current limitation	Active current limitation followed by a shutdown	
Dimensions	45x75x91mm *) WxHxD	

\*) Add 13mm in depth for signal connector.

### ORDER NUMBERS

Protection module	Output Ratings
<b>PISA11.401</b>	1A, 1A, 1A, 1A
<b>PISA11.402</b>	2A, 2A, 2A, 2A
<b>PISA11.403</b>	3A, 3A, 3A, 3A
<b>PISA11.404</b>	4A, 4A, 4A, 4A
<b>PISA11.406</b>	6A, 6A, 6A, 6A
<b>PISA11.410</b>	10A, 10A, 10A, 10A
<b>PISA11.203206</b>	3A, 3A, 6A, 6A
<b>PISA11.206212</b>	6A, 6A, 12A, 12A

**Please note:** An additional, NEC Class 2 optimized module (PISA11.CLASS2), can be found in a separate datasheet.

### MARKINGS



Class I Div 2

## INDEX

	Page		Page
1. Intended Use .....	3	16. Terminals and Wiring.....	15
2. Product Description.....	3	17. Input Wire Sizes.....	15
3. Installation Requirements.....	3	18. Output Wire Sizes.....	15
4. Input .....	5	19. EMC .....	16
5. Outputs.....	6	20. Environment .....	17
6. Current Limitation and Shutdown Behavior.....	7	21. Protection Features .....	18
7. Connecting Capacitive Loads to the Outputs.....	9	22. Dielectric Strength.....	18
8. Output-OK Relay Contact .....	11	23. Approvals.....	19
9. ON/OFF and Reset Signal Input .....	11	24. Fulfilled Standards.....	19
10. Synchronization of Multiple PISA Modules .....	11	25. Read-out of the Software Revision Level .....	20
11. Functional Diagram.....	12	26. Physical Dimensions and Weight.....	21
12. Back-feeding Loads .....	12	27. Accessory.....	21
13. Power Losses.....	13	27.1. ZM3.WALL Wall Mounting Bracket.....	21
14. Reliability.....	13	28. Various Measurement Results.....	22
15. Front Side and User Elements.....	14		

The information presented in this document is believed to be accurate and reliable and may change without notice.

The housing is patent by PULS (US patent No US D442,923S).

No part of this document may be reproduced or utilized in any form without permission in writing from the publisher (PULS GmbH). This also applies to all kinds of electronic publishing.

## TERMINOLOGY AND ABBREVIATIONS

<b>DC 24V</b>	A figure displayed with the AC or DC before the value represents a nominal voltage with standard tolerances (usually $\pm 15\%$ ) included.
	E.g.: DC 12V describes a 12V battery disregarding whether it is full (13.7V) or flat (10V)
<b>24Vdc</b>	A figure with the unit (Vdc) at the end is a momentary figure without any additional tolerances included.

## 1. INTENDED USE

This device is designed for installation in an enclosure and is intended for the general use such as in industrial control, office, communication, and instrumentation equipment.

Do not use this device in aircraft, trains, nuclear equipment or similar systems where malfunction may cause severe personal injury or threaten human life.

This device is designed for use in hazardous, non-hazardous, ordinary or unclassified locations.

## 2. PRODUCT DESCRIPTION

This protection module fulfills two basic functions. First it distributes the current of a large power source to four lower current output channels and therefore allows for smaller wires to be used. The second function is to permit only so much current on the outputs that the input voltage of this unit (which corresponds to the output voltage of the power supply) does not fall below 21V. This ensures a reliable supply voltage for sensitive equipments, such as PLCs, controls or sensors, when they are connected directly to the same power supply as the PISA protection module.

The protection module has one 24V input and four output channels to which the current is distributed. Each output channel is equipped with a redundant over-current protection, which avoids that wires will be overloaded. All four output channels will shutdown simultaneously, if the current of one individual channel or the maximum allowed current for the protection module is exceeded.

A safeguard circuit in the input stage of the PISA module works like a valve. It permits only so much current that the input voltage does not drop below 21V. In case the input voltage would fall below this value (e.g. due to overloads, too small of a power supply or high inrush currents such as from starting a motor), all four output channels will be actively current limited and will shutdown after a certain period of time.

A typical wiring configuration is shown below. All sensitive loads are connected directly to the power supply. If needed, these load circuits can be protected with standard circuit breakers or fuses. Loads which are less sensitive to voltage dips or interruptions or which are the source of the voltage drop themselves are connected to the output of the PISA protection module.

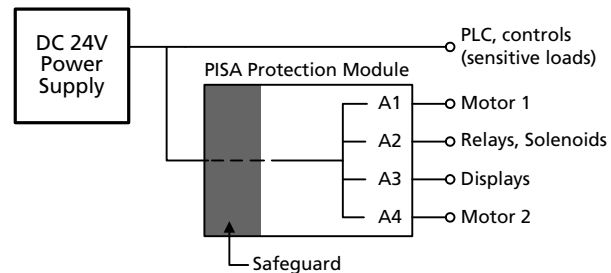

## 3. INSTALLATION REQUIREMENTS

This protection module is suitable for DIN-rail mounting. Use DIN-Rails according to EN 60715 or EN 50022 with a height of 7.5 or 15mm.

The protection module can be used with any regulated 24Vdc power supply. If the power source can deliver more than 40A continuous, the PISA module shall be equipped with an external input fuse (e.g. 30/32A). The power capability and performance of the power supply can limit the output characteristics of the PISA module.

Make sure that the input voltage polarity is correct before applying the input voltage.

Do not connect batteries to the outputs of the PISA11 module.

This device may only be installed and put into operation by qualified personnel.

The unit does not contain serviceable parts.

If damage or malfunction should occur during operation, immediately turn power off and send unit to the factory for inspection.

This device is designed for convection cooling and does not require an external fan. Do not obstruct airflow and do not cover ventilation grid.

The standard mounting orientation is input terminals on the bottom and output terminals on the top. Do not use the unit in other mounting orientations.

Keep the following installation clearances:

- Top and bottom: min. 40mm on top, 20mm on the bottom
- Left and right: min. 0mm if the total output current of the PISA module is less than 15A  
min. 6.4mm if the total output current is equal or higher than 15A and the ambient temperature is between 45°C and 60°C.  
min. 6.4mm if the ambient temperature is above 60°C (except for PISA11.401, PISA11.402 and PISA11.403).

A high voltage drop between the power supply and the protection module might cause a malfunction. It is not recommended to use wires longer than 2x2m (for 2.5mm<sup>2</sup> or AWG14 wires) or 2x4m (for 4mm<sup>2</sup> or AWG12 wires) to avoid undesired undervoltage conditions on the input of the protection module.

At ambient temperatures above 50°C and output currents higher than 15A (sum of all four channels), do not use a wire size smaller than 2.5mm<sup>2</sup> (or AWG14) and use wiring scheme Fig. 3-2.

Fig. 3-1 Standard wiring scheme

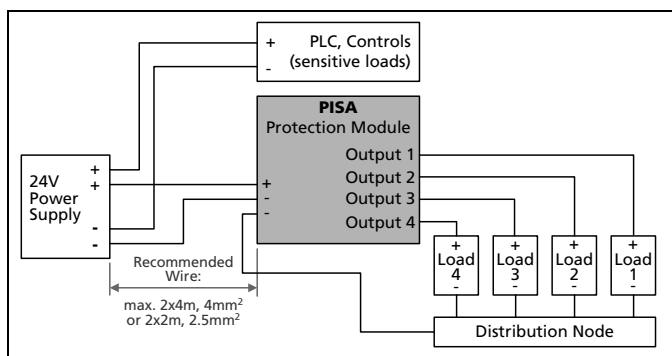
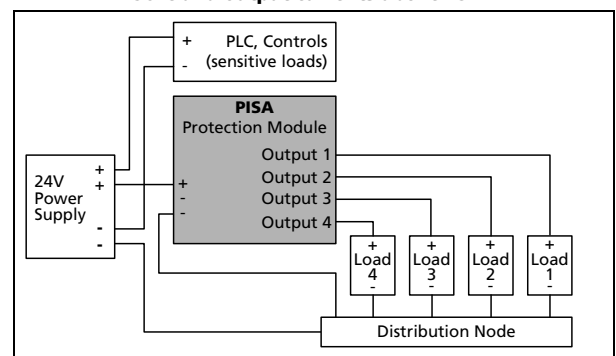

Fig. 3-2 Wiring scheme for ambient temperatures above 50°C and output currents above 15A



**⚠ WARNING** Risk of electrical shock, fire, personal injury or death.

- Turn power off before working on the device. Protect against inadvertent re-powering.
- Make sure that the wiring is correct by following all local and national codes.
- Do not modify or repair the unit.
- Do not open the unit.
- Use caution to prevent any foreign objects from entering the housing.
- Do not use in wet locations or in areas where moisture or condensation can be expected.

### Notes for use in hazardous location areas:

The units are suitable for use in Class I Division 2 Groups A, B, C, D locations.

The units are suitable for use in Group II Category 3 (Zone 2) environments and are evaluated according to EN 60079-0:2009 and EN 60079-15:2010.

### WARNING EXPLOSION HAZARDS!

Substitution of components may impair suitability for this environment. Do not disconnect the unit or operate the reset button unless power has been switched off or the area is known to be non-hazardous. The signal-connector may not be used in hazardous location areas unless additional measures are met to avoid an unintended disconnection (e.g. an additional mechanical fixation). The connection must meet the requirements of the EN 60079-15:2010. A suitable enclosure must be provided for the end product which has a minimum protection of IP54 and fulfils the requirements of the EN 60079-15:2010.

## 4. INPUT

Input voltage	nom.	DC 24V	±25%
Input voltage range	-	18Vdc – 30Vdc	Absolute maximum continuous input voltage with no damage to the PISA module
	max.	30Vdc	
Turn-on voltage	typ.	21.4Vdc	Required input voltage for turning-on the outputs
Turn-on delay of outputs	typ.	270ms	Period between applying the input voltage and turning on the outputs. All outputs will be turned-on at the same time.
Input voltage protection level *)	min.	21.0Vdc	Below this voltage level, outputs will shutdown.
	max.	21.8Vdc	
Stand-by input current	typ.	43mA	Stand-by current with no load current on the outputs

\*) Voltage dips below this value can occur for maximal 200µs.

## 5. OUTPUTS

			<b>PISA11.401</b>	<b>PISA11.402</b>	<b>PISA11.403</b>	<b>PISA11.404</b>
Output current	output 1	nom.	1A	2A	3A	4A
	output 2	nom.	1A	2A	3A	4A
	output 3	nom.	1A	2A	3A	4A
	output 4	nom.	1A	2A	3A	4A
All 4 outputs together		nom.	4A	8A	12A	16A
NEC CLASS 2 compliance			yes	yes	no	no
Output current limitation *)		min.	9A	9A	16.6A	16.6A
		typ.	10.7A	10.7A	19.9A	19.9A
		max.	12.7A	12.7A	23.6A	23.6A
Voltage drop **)	per output	typ.	41mV	83mV	75mV	101mV
Output leakage current ***)		typ.	0.4mA	0.4mA	0.4mA	0.4mA

			<b>PISA11.406</b>	<b>PISA11.410</b>	<b>PISA11.203206</b>	<b>PISA11.206212</b>
Output current	output 1	nom.	6A	10A	3A	6A
	output 2	nom.	6A	10A	3A	6A
	output 3	nom.	6A	10A	6A	12A
	output 4	nom.	6A	10A	6A	12A
All 4 outputs together		nom.	20A	20A	18A	20A
NEC CLASS 2 compliance			no	no	no	no
Output current limitation*)		min.	20.5A	20.5A	20.5A	20.5A
		typ.	25A	25A	25A	25A
		max.	30A	30A	30A	30A
Voltage drop **)	output 1, 2	typ.	124mV	197mV	92mV	178mV
	output 3, 4	typ.	124mV	197mV	107mV	182mV
Output leakage current ***)		typ.	0.4mA	0.4mA	0.4mA	0.4mA

\*) The current limitation value for the sum of all four output currents. This current can be drawn from each individual output regardless whether it is a 1A, 2A, 3A, 4A, 6A, 10A or 12A output. According to the specified ampacity of the outputs, the current can flow for a shorter or longer period before the protection module shutdown all four outputs at the same time. Shutdown times can be found in chapter 6.

\*\*) Voltage loss between input and output, when all output channels are loaded with 50% of its nominal current.

\*\*\*) Output current when outputs have shut down.

## 6. CURRENT LIMITATION AND SHUTDOWN BEHAVIOR

The PISA11 protection module comprises one common limitation and switching element for all four outputs. In a protection event, all four outputs limit the current or shutdown at the same time.

The following reasons can cause a limitation of the output currents or a shutdown of the output channels:

- 1) The output current of one or more output channels was too high.
- 2) The sum of the output current of all four output channels was exceeded.
- 3) The outputs needed to be shutdown in order to maintain sufficient input voltage.

**Shutdown times<sup>\*)</sup> when exceeding the rated output current:**

		<b>PISA11.401</b> (4x1A)	<b>PISA11.402</b> (4x2A)	<b>PISA11.403</b> (4x3A)	<b>PISA11.404</b> (4x4A)
<b>At 2x the rated current</b>	typ.	1s at 2A	1s at 4A	1s at 6A	1s at 8A
<b>At short circuit</b>	typ.	110ms	110ms	10ms	10ms

		<b>PISA11.406</b> (4x6A)	<b>PISA11.410</b> (4x10A)	<b>PISA11.203206</b> (2x3A, 2x6A)	<b>PISA11.206212</b> (2x6A, 2x12A)
<b>At 2x rated current</b>	output 1, 2 typ.	1s at 12A	1s at 20A	1s at 6A	1s at 12A
	output 3, 4 typ.	1s at 12A	1s at 20A	1s at 12A	1s at 24A
<b>At short circuit</b>	output 1, 2 typ.	8ms	8ms	8ms	8ms
	output 3, 4 typ.	8ms	8ms	8ms	8ms

<sup>\*)</sup> The timer for shutdown starts immediately once the rated current levels are exceeded. All output channels will shutdown, if one channel is overloaded. See Fig. 6-1 for more values.  
A shutdown of the outputs can also happen earlier, e.g. when the PISA module has to protect the supply voltage in case the power supply can not deliver enough current to support all loads without going into overload.

Fig. 6-1 Shutdown characteristic for 1A, 2A, 3A, 4A, 6A and 10A output channels

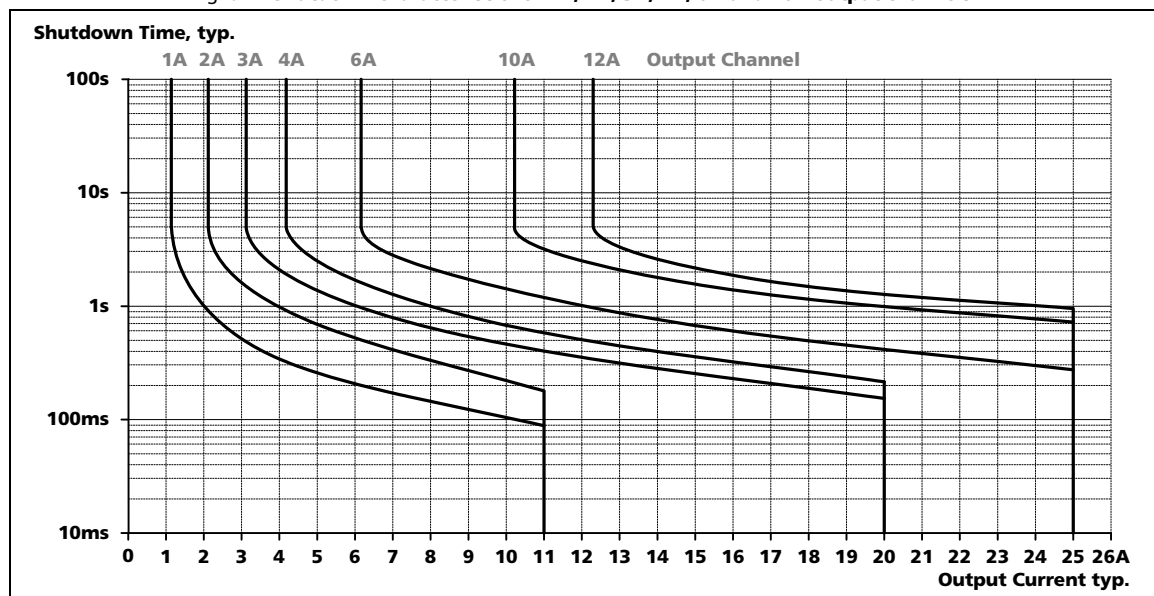

### Shutdown behavior to avoid under-voltage situations on the supply voltage

A further limitation of the output current activates when the supplying power source can not deliver enough current to support all loads without bringing the power source into overload followed by a voltage drop. In such an event, the voltage dependent current limitation of the input stage of the protection module is activated (safeguard circuit). This safeguard circuit acts like a valve only permitting so much current so that the supply voltage does not fall below 21V. The period of time for how long the protection circuit is able to actively limit the current depends on the difference between input and output voltage and the current which flows through the PISA protection module and is limited to a maximum of 5s. All four outputs will shutdown simultaneously.

Shutdown times for a short circuit condition across the outputs can be found in Fig. 6-2.

Fig. 6-2 Active current limitation – Period of time in current limiting mode until the outputs will shutdown

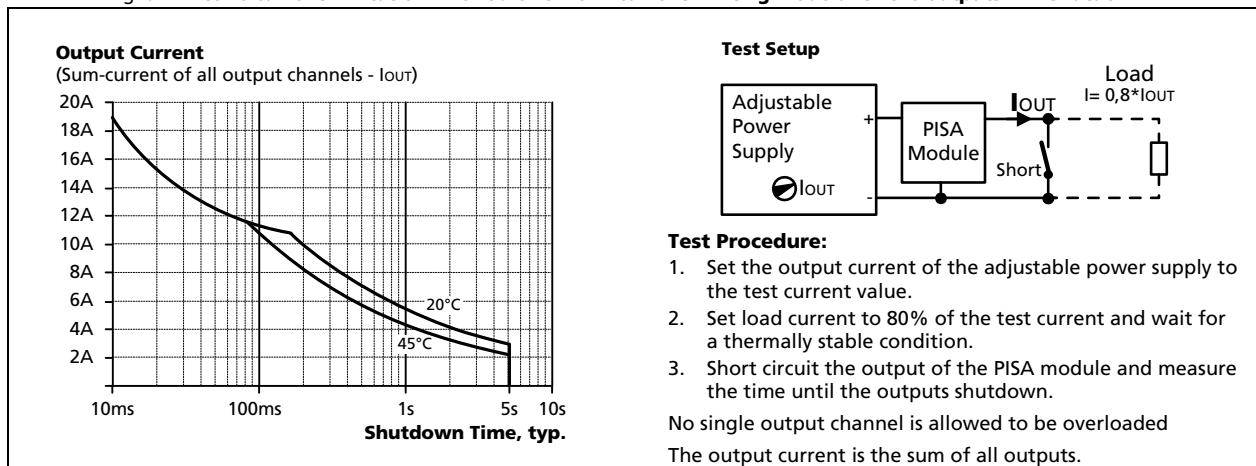



## 7. CONNECTING CAPACITIVE LOADS TO THE OUTPUTS

Large input capacitors of drives, monitors or other similar loads can result in an unintended shutdown of the module when trying to turn-on such loads. This especially can occur after a reset or by turning on a load via the push button or the external signal input. The PISA protection module is designed to be exceptionally compatible with such types of loads. The module can turn-on as much capacitance as possible and comprises several different protection mechanisms to protect against an unintended shutdown or damage of the unit.

The permissible capacitor sizes which can be connected to the output of the PISA module depends on the load current itself as well as on the characteristic of the load.

The following tables show two typical cases (case A and case B) for the permissible capacitors, which can be connected on the outputs without shutdown of the protection module. The listed values are valid for the entire temperature range.

### Case A: All outputs are loaded.

The minimum values are worst-case figures for the permissible capacitors which are defined with an additional constant current load and with the maximum permissible total current of the PISA protection module. See also the parameter list below the table.

The typical values are defined with an additional resistive load. See also the parameter list below the table.

Permissible Capacitors		PISA11.401 (4x1A)	PISA11.402 (4x2A)	PISA11.403 (4x3A)	PISA11.404 (4x4A)
Per channel	typ.	48mF	94mF	69mF	57mF
	min.	41mF	43mF	22mF	11mF
All four outputs together	typ.	135mF	124mF	69mF	57mF
	min.	94mF	43mF	22mF	11mF

Permissible Capacitors		PISA11.406 (4x6A)	PISA11.410 (4x10A)	PISA11.203206 (2x3A, 2x6A)	PISA11.206212 (2x6A, 2x12A)
For channel 1 & 2	typ.	42mF	33mF	43mF	34mF
	min.	9mF	8mF	11mF	8mF
For channel 3 & 4	typ.	42mF	33mF	48mF	33mF
	min.	9mF	8mF	12mF	8mF
All four outputs together	typ.	42mF	33mF	48mF	33mF
	min.	9mF	8mF	12mF	8mF

	Parameters for typical values	Parameters for minimum values
PISA11.401	0.5A resistive load per output	1A constant current load per output
PISA11.402	1A resistive load per output	2A constant current load per output
PISA11.403	1.5A resistive load per output	3A constant current load per output
PISA11.404	2A resistive load per output	4A constant current load per output
PISA11.406	3A resistive load per output	5A constant current load per output
PISA11.410	5A resistive load per output	5A constant current load per output
PISA11.203206	1.5A resistive load for outputs 1 & 2 3A resistive load for outputs 3 & 4	3A constant current load for outputs 1 & 2 6A constant current load for outputs 3 & 4
PISA11.206212	3A resistive load for outputs 1 & 2 6A resistive load for outputs 3 & 4	5A constant current load for outputs 1 & 2 5A constant current load for outputs 3 & 4

**Case B: Only one output is loaded**

The minimum values for the permissible capacitors are defined with an additional constant current load according to the parameter list below. During the tests, only one output is loaded and all others are not.

The typical values for the permissible capacitors are defined with an additional resistive load according to the parameter list below. During the tests, only one output is loaded and all others are not.

Permissible Capacitors		PISA11.401 (4x1A)	PISA11.402 (4x2A)	PISA11.403 (4x3A)	PISA11.404 (4x4A)
Per channel	typ.	49mF	92mF	80mF	71mF
	min.	41mF	73mF	49mF	45mF

Permissible Capacitors		PISA11.406 (4x6A)	PISA11.410 (4x10A)	PISA11.203206 (2x3A, 2x6A)	PISA11.206212 (2x6A, 2x12A)
For channel 1 & 2	typ.	58mF	44mF	56mF	59mF
	min.	38mF	24mF	38mF	36mF
For channel 3 & 4	typ.	58mF	44mF	50mF	42mF
	min.	38mF	24mF	31mF	20mF

- |                                                                                                                                                                                                                |                                                                                                                                                                                                                                                                                                                                                                                                                                                                                                                                                                                                                                          |                                                                                                                                                                                                                                                                                                                                                                                                                                                                                                                                                                                                                                                                                           |
|----------------------------------------------------------------------------------------------------------------------------------------------------------------------------------------------------------------|------------------------------------------------------------------------------------------------------------------------------------------------------------------------------------------------------------------------------------------------------------------------------------------------------------------------------------------------------------------------------------------------------------------------------------------------------------------------------------------------------------------------------------------------------------------------------------------------------------------------------------------|-------------------------------------------------------------------------------------------------------------------------------------------------------------------------------------------------------------------------------------------------------------------------------------------------------------------------------------------------------------------------------------------------------------------------------------------------------------------------------------------------------------------------------------------------------------------------------------------------------------------------------------------------------------------------------------------|
| <ul style="list-style-type: none"> <li>PISA11.401</li> <li>PISA11.402</li> <li>PISA11.403</li> <li>PISA11.404</li> <li>PISA11.406</li> <li>PISA11.410</li> <li>PISA11.203206</li> <li>PISA11.206212</li> </ul> | <p><b>Parameters for typical values</b><br/>                 with additional 0.5A resistive load<br/>                 with additional 1A resistive load<br/>                 with additional 1.5A resistive load<br/>                 with additional 2A resistive load<br/>                 with additional 3A resistive load<br/>                 with additional 5A resistive load<br/>                 3A: with additional 1.5A resistive load<br/>                 6A: with additional 3A resistive load<br/>                 6A: with additional 3A resistive load<br/>                 12A: with additional 6A resistive load</p> | <p><b>Parameters for minimum values</b><br/>                 with additional 1A constant current load<br/>                 with additional 2A constant current load<br/>                 with additional 3A constant current load<br/>                 with additional 4A constant current load<br/>                 with additional 6A constant current load<br/>                 with additional 10A constant current load<br/>                 with additional 3A constant current load<br/>                 with additional 6A constant current load<br/>                 with additional 6A constant current load<br/>                 with additional 12A constant current load</p> |
|----------------------------------------------------------------------------------------------------------------------------------------------------------------------------------------------------------------|------------------------------------------------------------------------------------------------------------------------------------------------------------------------------------------------------------------------------------------------------------------------------------------------------------------------------------------------------------------------------------------------------------------------------------------------------------------------------------------------------------------------------------------------------------------------------------------------------------------------------------------|-------------------------------------------------------------------------------------------------------------------------------------------------------------------------------------------------------------------------------------------------------------------------------------------------------------------------------------------------------------------------------------------------------------------------------------------------------------------------------------------------------------------------------------------------------------------------------------------------------------------------------------------------------------------------------------------|

Fig. 7-1 Test setup for capacitive load measurements

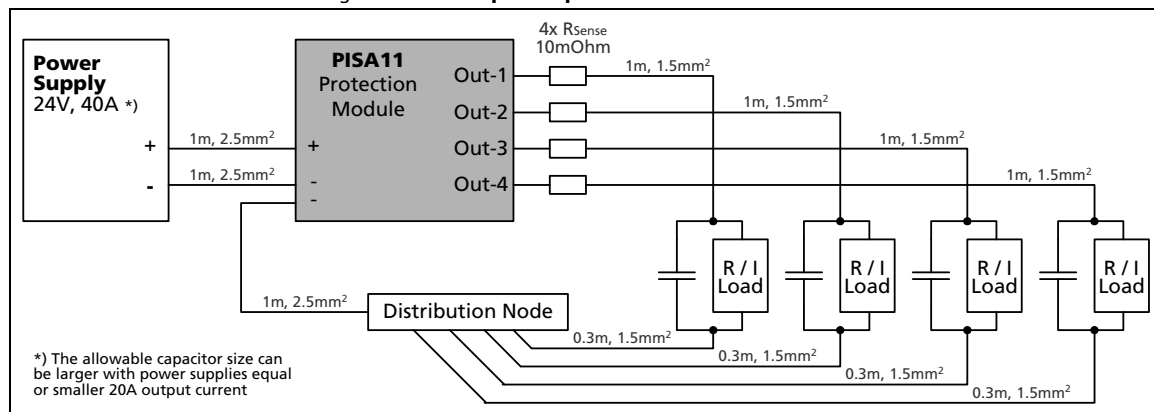

## 8. OUTPUT-OK RELAY CONTACT

This relay contact is closed when the input voltage is sufficient and the outputs are not shutdown.

Threshold voltage	typ.	21.4Vdc	Required voltage to power the relay and to close the relay contact. The outputs must also not be shutdown.
Contact ratings	max.	30Vdc, 1.0A	Resistive load
	max.	30Vac, 0.5A	Resistive load
	min.	1mA at 5Vdc	
Galvanic isolation	nom.	500Vac	Test voltage: Signal path to power path

## 9. ON/OFF AND RESET SIGNAL INPUT

This signal input is galvanically isolated with an integrated optocoupler and works in the same manner as the reset and ON/OFF button. The ON/OFF function has no safety feature included.

In a failure mode (outputs have shutdown), the outputs can be turned on again by applying a voltage for more than 1 second.

In normal mode (outputs have not shutdown), a short (> 50ms) voltage pulse will turn all outputs ON or OFF.

The unit will be shipped (factory setting) with the outputs turned-on.

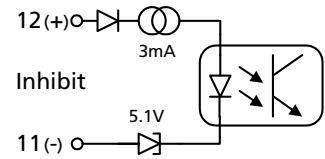

Signal voltage	max.	30Vdc	
Signal current	typ.	3mA	Active current limited
	max.	6mA	active current limited
Threshold voltage levels	min	6Vdc	Voltages above this level will trigger the inhibit or reset.
	max.	10Vdc	
Galvanic isolation	nom.	500Vac	Test voltage: signal path to power path

## 10. SYNCHRONIZATION OF MULTIPLE PISA MODULES

If multiple PISA modules are used on the same power supply, it is recommended to connect the sync. bus of all modules together. If one unit shuts down due to the protection function of the input voltage protection circuit (safeguard), all other modules will shutdown too. This avoids a false interpretation of which output channel caused the problem. If the sync. terminals are not linked, the module with the highest safeguard protection voltage level (caused by tolerances) would shutdown first regardless whether the failure was caused by this module or not.

Please note:

If the cause for the shutdown was an over-current of one individual channel only this module will shutdown and the other modules will stay on. In this case the sync. line has no impact on the other modules.

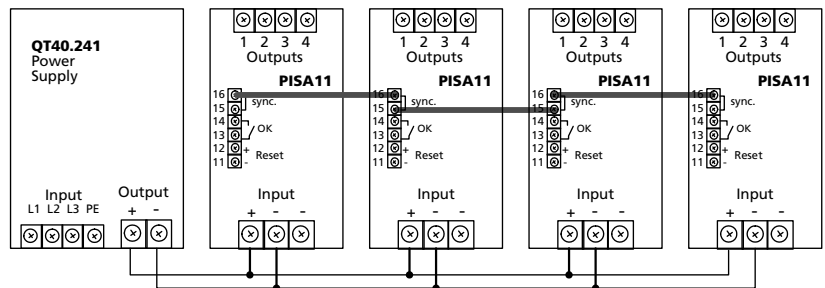

## 11. FUNCTIONAL DIAGRAM

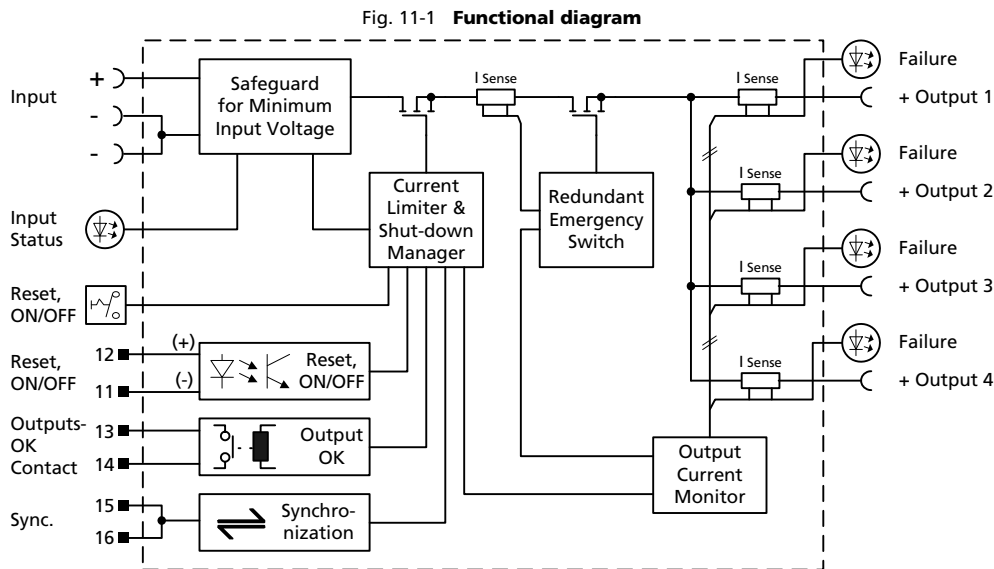

## 12. BACK-FEEDING LOADS

Loads such as decelerating motors and inductors can feed voltage back to the PISA11 protection module. This feature is also called return voltage immunity or resistance against Back- E.M.F. (Electro Magnetic Force).

The protection module is resistant and does not show malfunctioning when a load feeds back voltage up to 30Vdc to the protection module. It does not matter whether the protection module is on or off.

The protection module has no capability to absorb energy. Internal diodes (integrated body diodes of the Mosfets) directs the voltage and energy to the power supply, which is connected on the input side of the protection module. The power supply defines the amount of energy which can be absorbed.

## 13. POWER LOSSES

		<b>PISA11.401</b>	<b>PISA11.402</b>	<b>PISA11.403</b>	<b>PISA11.404</b>
No-load losses	typ.	1.0W	1.0W	1.0W	1.0W
Losses at typical output loads <sup>*)</sup>	typ.	1.0W	1.3W	1.4W	1.8W
		<b>PISA11.406</b>	<b>PISA11.410</b>	<b>PISA11.203206</b>	<b>PISA11.206212</b>
No-load losses	typ.	1.0W	1.0W	1.0W	1.0W
Losses at typical output loads <sup>*)</sup>	typ.	2.4W	4.9W	1.9W	4.2W

<sup>\*)</sup> Typical value when all output channels are loaded with 50% of its nominal current.

## 14. RELIABILITY

The PISA protection modules are extremely reliable and use only the highest quality materials. The number of critical components such as electrolytic capacitors have been reduced.

		<b>PISA11.401</b>	<b>PISA11.402</b>	<b>PISA11.403</b>	<b>PISA11.404</b>
Applied load		4x0.5A	4x1A	4x1.5A	4x2A
Lifetime expectancy <sup>*)</sup>		243 000h <sup>*)</sup> 686 000h <sup>*)</sup>	233 000h <sup>*)</sup> 658 000h <sup>*)</sup>	229 000h <sup>*)</sup> 649 000h <sup>*)</sup>	216 000h <sup>*)</sup> 610 000h <sup>*)</sup>
MTBF <sup>**)</sup> SN 29500, IEC 61709		2 347 000h 4 039 000h	2 323 000h 3 998 000h	2 283 000h 3 930 000h	2 114 000h 3 638 000h
MTBF <sup>**)</sup> MIL HDBK 217F, GB		790 000h 1 090 000h	775 000h 1 066 000h	762 000h 1 048 000h	705 000h 970 000h
		<b>PISA11.406</b>	<b>PISA11.410</b>	<b>PISA11.203206</b>	<b>PISA11.206212</b>
Applied load		4x3A	4x5A	2x1.5A + 2x3A	2x3A + 2x5A
Lifetime expectancy <sup>*)</sup>		203 000h <sup>*)</sup> 573 000h <sup>*)</sup>	155 000h <sup>*)</sup> 437 000h <sup>*)</sup>	213 000h <sup>*)</sup> 604 000h <sup>*)</sup>	171 000h <sup>*)</sup> 485 000h <sup>*)</sup>
MTBF <sup>**)</sup> SN 29500, IEC 61709		1 942 000h 3 377 000h	1 296 000h 2 305 000h	2 095 000h 3 605 000h	1 373 000h 2 443 000h
MTBF <sup>**)</sup> MIL HDBK 217F, GB		583 000h 766 000h	448 000h 589 000h	699 000h 961 000h	475 000h 624 000h

<sup>\*)</sup> The Lifetime expectancy shown in the table indicates the minimum operating hours (service life) and is determined by the lifetime expectancy of the built-in electrolytic capacitors. Lifetime expectancy is specified in operational hours and is calculated according to the capacitor's manufacturer specification. The manufacturer of the electrolytic capacitors only guarantees a maximum life of up to 15 years (131 400h). Any number exceeding this value is a calculated theoretical lifetime which can be used to compare devices.

<sup>\*\*)</sup> **MTBF** stands for **Mean Time Between Failure**, which is calculated according to statistical device failures, and indicates reliability of a device. It is the statistical representation of the likelihood of a unit to fail and does not necessarily represent the life of a product. The MTBF figure is a statistical representation of the likelihood of a device to fail. A MTBF figure of e.g. 1 000 000h means that statistically one unit will fail every 100 000 units are installed in the field. However, it can not be determined if the failed unit has been running for 50 000h or only for 100h.

### 15. FRONT SIDE AND USER ELEMENTS

**A Output Terminals** (plus (+) pole connection points)

**B Red Failure LEDs**

The red LEDs are failure indicators. Any time a red LED is on or blinking, the outputs have been shutdown.

Three reasons why the outputs have been shutdown:

- 1) The output current of one or more individual output channels was too high. In this case, the affected output channel LED is blinking and all others are illuminated.
- 2) The sum of the output current of all four output channels was exceeded. In this case, all red LEDs are blinking.
- 3) The outputs needed to be shutdown in order to maintain sufficient input voltage. In this case, all red LEDs are on and the green LED (Input Status) is blinking.

The outputs can also be turned off by pushing the ON/OFF button on the front of the unit or by applying an external signal to the ON/OFF signal input. In this case, all red LEDs are on.

When LED 1 and 4 as well as the LEDs 2 and 3 are alternately blinking, an internal error has occurred. Try to reset the unit by pushing the reset button. If this does not help, ship the unit to the factory for inspection.

**C ON/OFF and Reset Button**

This is a pushbutton which can be used for two purposes:

- 1) In a failure mode (outputs have shutdown), the outputs can be turned on again by pushing and holding the reset button for more than 1 second.
- 2) In normal mode (outputs have not shutdown), a short (> 50ms) push will turn all outputs ON or OFF.

The unit will be shipped (factory setting) with the outputs turned-on. The ON/OFF function has no safety feature included.

**D Synchronization Bus** (connection by plug-connector on the front), See also chapter 10.

If multiple PISA modules are used on the same power supply, it is recommended to connect the sync. bus of all modules together. If one unit shuts down due to the protection function of the input voltage protection circuit, all other modules will shutdown too. This avoids a false interpretation of which output channel caused the problem. If the cause for the shutdown was an over-current of one individual channel only this module will shutdown and the other modules will stay on. In this case the sync. line has no impact on the other modules.

**E Output-OK Relay Contact** (connection by plug-connector on the front), See also chapter 8.

This relay contact is closed when the input voltage is sufficient and all outputs are not shutdown.

**F Inhibit / Reset Signal Input** (connection by plug-connector on the front), See also chapter 9.

This signal input is galvanically isolated with an integrated optocoupler and works in the same manner as the reset and ON/OFF button. The ON/OFF function has no safety feature included.

- 1) In a failure mode (outputs have shutdown), the outputs can be turned on again by applying a voltage for more than 1 second.
- 2) In normal mode (outputs have not shutdown), a short (> 50ms) voltage pulse will turn all outputs ON or OFF.

**G Green Input Status LED**

This LED indicates the status of the input. The green LED is illuminated if the input voltage is higher than 21Vdc. The green LED will blink when the input protection circuit (Safeguard) is activated in order to protect the supply voltage from dropping below 21V or when the outputs have already been shutdown due to a low input voltage.

**H Input Terminals**

Two minus (-) connection points for simpler load distribution or grounding (earthing) of the minus (-) pole.

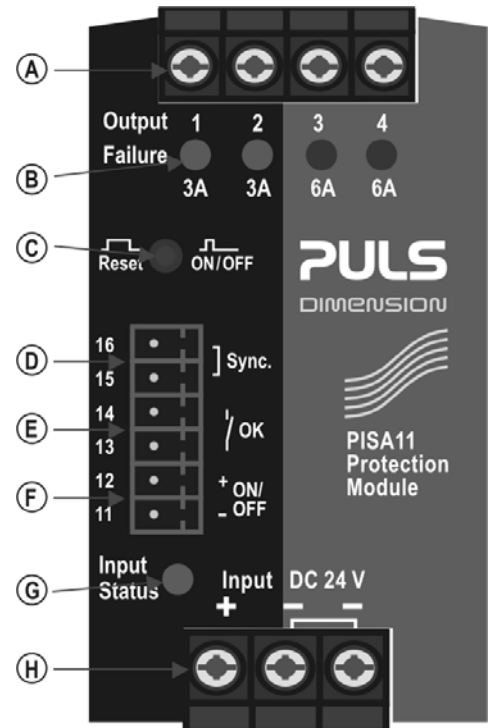

**Please note:**

Outputs which have shutdown must be turned on manually by pushing the reset button or by an external reset signal (ON/OFF signal input). A cycling of the input power does not reset the unit. The failure signals are stored until a reset is intentionally initiated.

## 16. TERMINALS AND WIRING

All terminals are easy to access when mounted on the panel.

Input, outputs and signal terminals are separated from each other to help in error-free wiring.

	<b>Input and Output</b>	<b>Signals</b>
<b>Type</b>	screw terminals	plug connector
Solid wire	0.2-6mm <sup>2</sup>	0.2-1.5mm <sup>2</sup>
Stranded wire	0.2-4mm <sup>2</sup>	0.2-1.5mm <sup>2</sup>
AWG (American Wire Gauge)	24-10 AWG	24-16 AWG
Wire stripping length	7mm / 0.28inch	6mm / 0.24inch
Screwdriver	3.5mm slotted or Pozidrive No 2	2.5mm slotted
Recommended tightening torque	0.8Nm, 7lbs.in	0.35Nm, 3lbs.in

### Instructions:

- Use appropriate copper cables that are designed for minimum operating temperatures of:  
60°C for ambient up to 45°C and minimum  
75°C for ambient up to 60°C and minimum  
90°C for ambient up to 70°C.
- Follow national installation codes and installation regulations!
- Ensure that all strands of a stranded wire enter the terminal connection!
- Up to two stranded wires with the same cross section are permitted in one connection point.
- Screws of unused terminal compartments should be securely tightened.
- Ferrules are allowed.

## 17. INPUT WIRE SIZES

A high voltage drop between the power supply and the protection module might cause a malfunction. It is not recommended to use wires longer than 2x2m (for 2.5mm<sup>2</sup> or AWG14 wires) or 2x4m (for 4mm<sup>2</sup> or AWG12 wires) to avoid undesired undervoltage conditions on the input of the protection module.

Use an appropriate wire size which matches to the ampacity of the power supply.

Do not use a wire size smaller than 2.5mm<sup>2</sup> (or AWG14), when the total output current is higher than 15A.

## 18. OUTPUT WIRE SIZES

One task of the PISA module is the distribution of the current from a large amperage power supply to four current monitored output channels. This permits wires with smaller cross-sections than would be needed for the ampacity of the power supply. Therefore, the PISA11 module is equipped with a redundant electronic current measurement and an additional emergency Mosfet to protect the wires. In case of an overload, all outputs will shutdown.

For the coordination between wire sizes and load currents, the relevant regulations must be observed. In most cases, these are VDE 0891, VDE 0100-523 and the IEC/EN 60204-1. This means that the following wire sizes shall be used in typical applications:

- 1A output: ≥0,14mm<sup>2</sup> (approximately equals AWG26)  
– Please note that the minimum wire size for the terminal is 0.2mm<sup>2</sup> / AWG24.
- 2A output: ≥0,25mm<sup>2</sup> (approximately equals AWG24)
- 3A output: ≥0,34mm<sup>2</sup> (approximately equals AWG22)
- 4A output: ≥0,50mm<sup>2</sup> (approximately equals AWG20)
- 6A output: ≥0,75mm<sup>2</sup> (approximately equals AWG18)
- 10A output: ≥1,0mm<sup>2</sup> (approximately equals AWG16)
- 12A output: ≥1,5mm<sup>2</sup> (approximately equals AWG14)

## 19. EMC

This protection module is suitable for applications in industrial environment as well as in residential, commercial and light industry environment without any restrictions. A detailed EMC report is available on request.

### EMC Immunity

Generic standards: EN 61000-6-1 and EN 61000-6-2

			Outputs ON	Outputs OFF	
Electrostatic discharge	EN 61000-4-2	Contact discharge *)	8kV	8kV	Criterion A
		Air discharge	8kV	8kV	Criterion A
Electromagnetic RF field	EN 61000-4-3	80MHz-2,7GHz	10V/m	10V/m	Criterion A
Fast transients (Burst)	EN 61000-4-4	Input lines	2kV	2kV	Criterion A
		output lines	2kV	2kV	Criterion A
		DC-OK, Inhibit	1kV	1kV	Criterion A
Surge voltage on input lines	EN 61000-4-5	+ → -	500V	500V	Criterion A
		+/- → DIN-Rail	1kV	1kV	Criterion A
Surge voltage on output lines	EN 61000-4-5	+ → -	500V	500V	Criterion A
		+/- → DIN-Rail	1kV	1kV	Criterion A
Surge voltage on signal lines	EN 61000-4-5	DC-OK, Inhibit → DIN-Rail	1kV	1kV	Criterion A
Conducted disturbance	EN 61000-4-6	0.15-80MHz	10V	10V	Criterion A

**Criterion A:** The PISA protection module shows normal operation behavior within the defined limits.  
\*)... on coupling plane

### EMC Emissions

Generic standards: EN 61000-6-3, EN 61000-6-4

Conducted emission	CISPR 16-1-2, CISPR 16-2-1			Class B **, DC input and DC-output
Radiated emission	EN 55011, EN 55022			Class B

\*\* ) provided that the supplying power source fulfills Class B too



## 20. ENVIRONMENT

Operational temperature *)	-25°C to +70°C (-13°F to 158°F)	for PISA11.401, PISA11.402, PISA11.403 without de-rating
	-25°C to +60°C (-13°F to 140°F)	for PISA11.404, PISA11.406, PISA11.410, PISA11.203206, PISA11.206210 without de-rating
Output de-rating	+60°C to +70°C (140°F to 158°F)	De-rate linearly to 15A between 60°C and 70°C for PISA11.404, PISA11.406, PISA11.410, PISA11.203206, PISA11.206210, see also Fig. 20-1 De-rate the output current equally between the individual outputs.
Storage temperature	-40 to +85°C (-40°F to 185°F)	
Humidity **)	5 to 95% r.H.	IEC 60068-2-30
Vibration sinusoidal	2-17.8Hz: ±1.6mm; 17.8-500Hz: 2g 2 hours / axis	IEC 60068-2-6
Shock	30g 6ms, 20g 11ms 3 bumps / direction, 18 bumps in total	IEC 60068-2-27
Altitude	0 to 6000m (0 to 20 000ft)	
Over-voltage category	III II	IEC 62103, EN 50178, altitudes up to 2000m for altitudes from 2000m to 6000m
Degree of pollution	2	IEC 62103, EN 50178, not conductive
LABS compatibility	The unit does not release any silicone or other LABS-critical substances and is suitable for use in paint shops.	

\*) Operational temperature is the same as the ambient temperature and is defined as the air temperature 2cm below the unit.

\*\*\*) Do not energize while condensation is present.

Fig. 20-1 **Total module output current vs. ambient temperature**

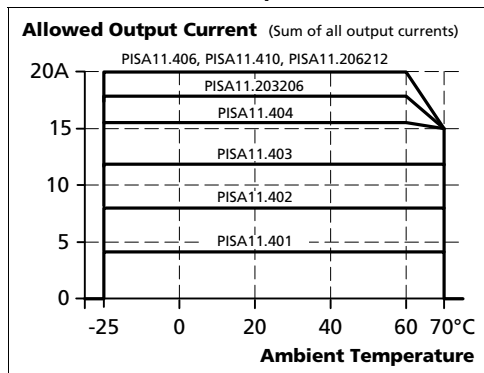

## 21. PROTECTION FEATURES

Output over-current protection	Electronically limited	
Class of protection	III	IEC 61140
Degree of protection	IP 20	EN/IEC 60529
Penetration protection	> 2.5mm in diameter	E.g. screws, small parts
Over-temperature protection	Not included	
Reverse polarity protection; input voltage	Not included	Make sure that the input voltage polarity is correct before applying the input voltage.
Internal input fuse	Not included	

## 22. DIELECTRIC STRENGTH

The relay contact and the ON/OFF signal input are floating and have no ohmic connection to the input or output voltage. Type and factory tests are conducted by the manufacturer.

The creepage and clearance distances between relay contacts, the ON/OFF signal input and input/output voltage are 1.3mm.

The following dielectric strength tests were conducted:



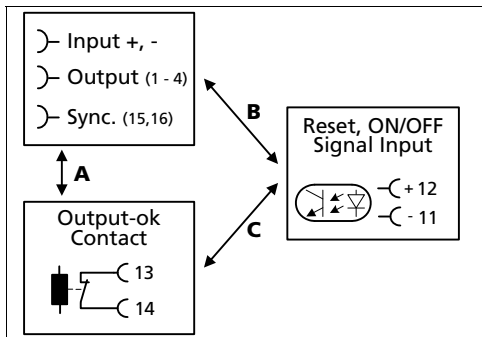





Fig. 22-1 Dielectric strength



		<b>A</b>	<b>B</b>	<b>C</b>
Type test	60s	500Vac	500Vac	50Vac
Factory test	5s	500Vac	500Vac	-
Field test	5s	500Vac	500Vac	50Vac
Cut-off current setting		> 1mA	> 1mA	> 1mA

Type and factory tests are conducted by the manufacturer. Field tests may be conducted in the field using the appropriate test equipment which applies the voltage with a slow ramp (2s up and 2s down). Connect all input and output terminals together as well as all signal poles before conducting the tests. When testing, set the cut-off current settings to the value in the table above.

## 23. APPROVALS

EC Declaration of Conformity		The CE mark indicates conformance with the: - EMC directive 2004/108/EC, - Low-voltage directive (LVD) 2006/95/EC, - RoHS directive 2011/65/EU and the - ATEX directive 94/9/EC
IEC 60950-1 2 <sup>nd</sup> Edition		CB Scheme, Safety of Information Technology Equipment
UL 508		Listed for the use as Industrial Control Equipment; U.S.A. (UL 508) and Canada (C22.2 No. 107-1-01); E-File: E198865
UL 60950-1 2 <sup>nd</sup> Edition		Recognized for the use as Information Technology Equipment, Level 5; U.S.A. (UL 60950-1) and Canada (C22.2 No. 60950); E-File: E137006
NEC Class 2, only PISA11.401, PISA11.402	<b>NEC CLASS 2</b>	Listed as Limited Power Source (LPS) in the UL 60950-1 UL report. According to NEC (National Electrical Code) Article 725-121 (A) (4).
UL 2367		Special-purpose Solid-State Overcurrent Protector Component Recognition; UL Category QVRQ2 E-File: E342020
ANSI / ISA 12.12.01- 2007 (Class I Div 2)		LISTED for use in Hazardous Location Class I Div 2 T4 Groups A,B,C,D systems; NRTL/C (Canada and U.S.)
EN 60079-15 ATEX	 II 3G EX nA nC IIC T4 Gc	Approval for use in hazardous locations Zone 2 Category 3G. Number of ATEX certificate: EPS 11 ATEX 1 327 X Evaluated according to EN 60079-0:2009 and EN 60079-15:2010
Marine planed		GL (Germanischer Lloyd) classified Environmental category: C, EMC2 Marine and Offshore applications
GOST P planed		Certificate of Conformity for Russia and other GUS countries

## 24. FULFILLED STANDARDS

EN/IEC 60204-1	Safety of Electrical Equipment of Machines
EN/IEC 61131-2	Programmable Controllers
EN 50178, IEC 62103	Electronic Equipment in Power Installations

## 25. READ-OUT OF THE SOFTWARE REVISION LEVEL

PISA utilizes a microcontroller with a dedicated firmware to control the whole unit. The revision level of the used firmware can be determined as follows:

Press and hold the reset button before applying the input voltage. The pattern of the four red LEDs shows the firmware revision level.

Revision level	LED 1	LED 2	LED 3	LED 4
<b>A</b>	OFF	OFF	OFF	ON
<b>B</b>	OFF	OFF	ON	OFF
<b>C</b>	OFF	OFF	ON	ON
<b>D</b>	OFF	ON	OFF	OFF
<b>E</b>	OFF	ON	OFF	ON
<b>F</b>	OFF	ON	ON	OFF
<b>G</b>	OFF	ON	ON	ON
<b>H</b>	ON	OFF	OFF	OFF
<b>I</b>	ON	OFF	OFF	ON
<b>J</b>	ON	OFF	ON	OFF
<b>K</b>	ON	OFF	ON	ON
<b>L</b>	ON	ON	OFF	OFF
<b>M</b>	ON	ON	OFF	ON
<b>N</b>	ON	ON	ON	OFF
<b>O</b>	ON	ON	ON	ON

## 26. PHYSICAL DIMENSIONS AND WEIGHT

Weight	120g / 0.26lb
DIN-Rail	Use 35mm DIN-rail according to EN 60715 or EN 50022 with a height of 7.5 or 15mm. The DIN-rail height must be added to the unit depth to calculate the total required installation depth.
Installation clearances	See chapter 3

Fig. 26-1 **Front view**

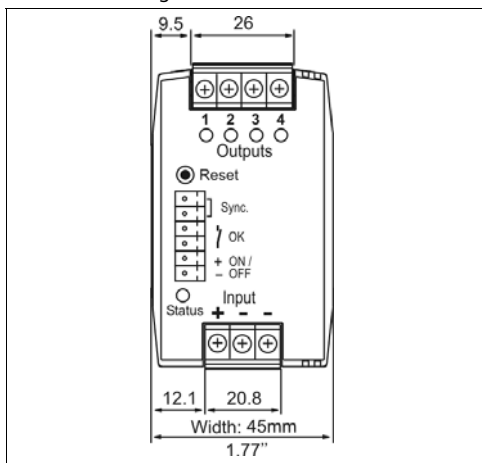
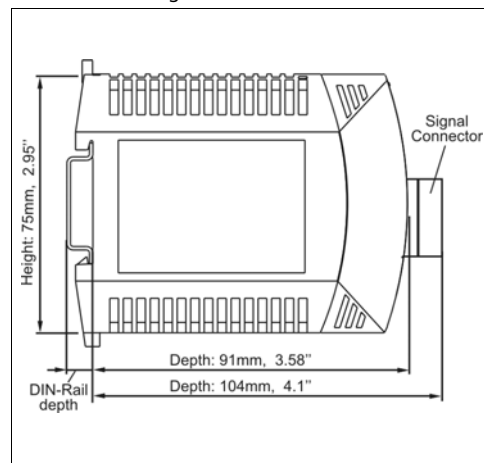

Fig. 26-2 **Side view**



## 27. ACCESSORY

### 27.1. ZM3.WALL WALL MOUNTING BRACKET

(bulk-package with 25 pcs.)

DIN-Rail bracket for wall or panel mount:

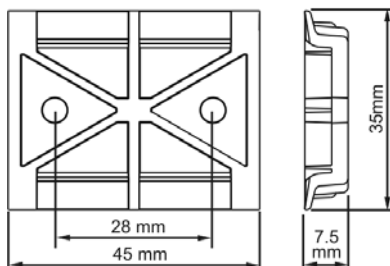

Hole diameter: 4.2mm

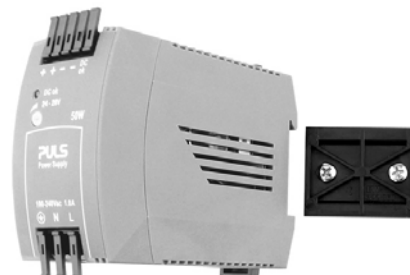

Note: The picture is for representation only.

### 28. VARIOUS MEASUREMENT RESULTS

Test setup for the following measurements:

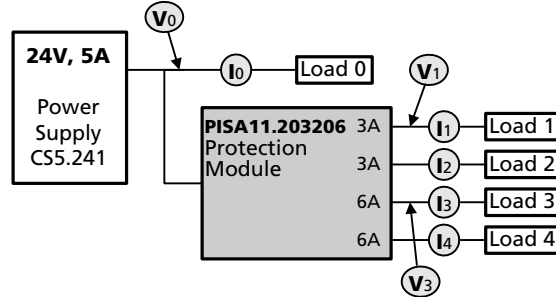

#### a) Short-circuit across a 6A output of a PISA11.203206 protection module

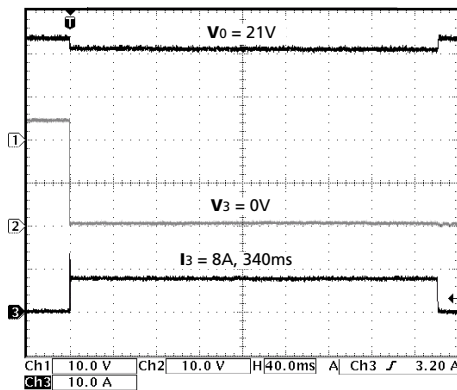

Parameters:  
 Power supply: 5A (CS5.241)  
 $I_0 = 0A$   
 $I_3 = \text{Short-circuit}$   
 $I_1, I_2, I_4 = 0A$

8A is flowing, which is the current level that can be drawn from the CS5.241 power supply without the supply voltage falling below 21V. The electronic circuit in the PISA protection module can actively limit this current for 340ms. After this time period, the outputs shutdown in order to protect the MOSFET in the PISA module.

Refer also to Fig. 6-2 of this datasheet.

#### b) Short-circuit across a 3A output of a PISA11.203206 protection module

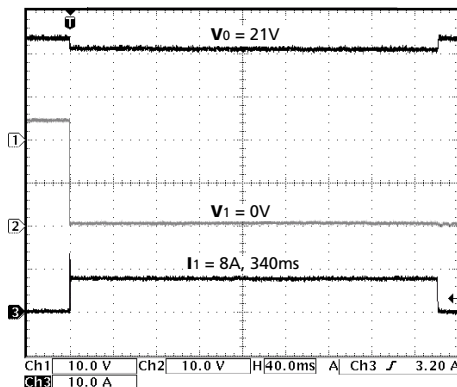

Parameters:  
 Power supply: 5A (CS5.241)  
 $I_0 = 0A$   
 $I_1 = \text{Short circuit}$   
 $I_2, I_3, I_4 = 0A$

Similar situation as above (short circuit across the 6A output). The same 8A is flowing, which is the current level that can be drawn from the CS5.241 power supply without the supply voltage falling below 21V. The electronic circuit in the PISA protection module can actively limit this current for 340ms. After this time period, the outputs shutdown in order to protect the MOSFET in the PISA module.

Refer also to Fig. 6-2 of this datasheet.

**c) 6A Overload (4 Ohm resistive load) of the 3A output of a PISA11.203206 protection module**

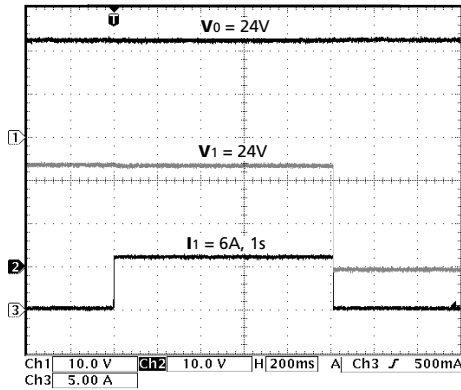

**Parameters:**  
 Power supply: 5A (CS5.241)  
 $I_0 = 0A$   
 $I_1 = 6A$  (4Ohm)  
 $I_2, I_3, I_4 = 0A$

6A is flowing on output 1, which can be drawn from the CS5.241 power supply with full output voltage. The electronic circuit in the PISA protection module allows this current for 1s. After this time period, the outputs shutdown in order to protect wires and loads.

Refer also to Fig. 6-1 of this datasheet.

**d) Both 6A outputs of a PISA11.203206 module loaded with 6A (4 Ohm resistive load)**

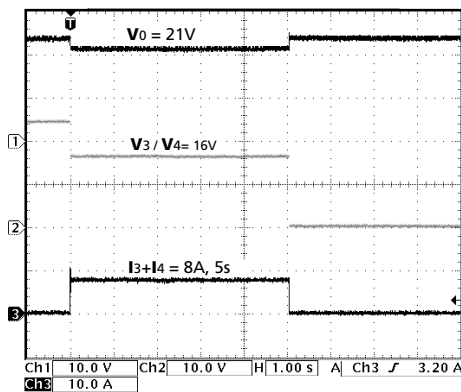

**Parameters:**  
 Power supply: 5A (CS5.241)  
 $I_0, I_1, I_2 = 0A$   
 $I_3, I_4 = 6A$  (4Ohm)

The power supply can not deliver the required current and switches into current limiting mode. The PISA module only permits so much current on the outputs so that the input voltage does not drop below 21V. With these conditions, there is only 16V ( $8A * 2Ohms$ ) on the outputs of the protection module.

The electronic circuit in the PISA protection module actively limits this current for 5s (fixed time setting) before the outputs shutdown. Please note that the time can be shorter if the internal MOSFET needs to be protected.

**e) The power supply is directly loaded with 4A (6 Ohm resistive load) and one 6A output of a PISA11.203206 module is loaded with 6A (4 Ohm resistive load)**

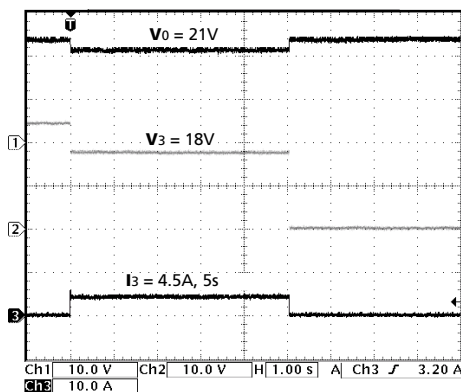

**Parameters:**  
 Power supply: 5A (CS5.241)  
 $I_0 = 4A$  (6 Ohm)  
 $I_3 = 6A$  (4 Ohm)  
 $I_1, I_2, I_4 = 0A$

The power supply can not deliver the required current and switches into current limiting mode. The PISA module only permits so much current on the outputs so that the input voltage does not drop below 21V. With these conditions, there is only 18V on the outputs of the protection module.

The electronic circuit in the PISA protection module limits this current actively and shutdown after 5s.

Refer also to Fig. 6-2 of this datasheet.