

5 A with PFC

# SL5.105

- Input: AC 115V / 230V, DC 210-375 V
- Output: 24...28V / 120 W
- Power Boost up to 144 W
- High overload current, no switch-off
- Quasi-Wide-Range Input
- Robust mechanics and EMV



**PULS**

CB  
scheme  
IEC60950

UL US

UL508 LISTED  
IND. CONT. EQ.  
18 WM, 60°C

UL US  
UL60950 E137005  
CUL/CSA-C22.2  
No 950-M90

CE

EMC and  
Low Volt.  
Directive

Data sheet

## Input

Input voltage AC100-120/220-240 V (switchable), 47-63 Hz (85-132 VAC / 176-264 VAC, 210-375 VDC, also see „Output: Continuous Loading“)

Quasi-Wide-Range Input: With the switch in the 230V position the power supply unit operates at low and moderate loads (until 3 A) at any input voltage between 95 and 264 V AC (see 'Output' at the right side). Note: At DC input, always leave the switch in the 230V position.

Input current < 2.6 A (switch in 115V position)  
< 1.2 A (switch in 230V position)

- DCin at open output typ. 5 mA (preserves battery sources)

Inrush current typ. < 15 A at 264 V AC and cold start

To be fused with a 10A, B-type 'circuit-breaker' switch based on the usual thermomagn. overload sensing principle (used anyway to fuse the input lines). In addition, the unit contains an internal fuse (not accessible).

Harmonic current acc. EN 61000-3-2  
emissions (PFC) Power factor: 0.71 at nominal load

Transient handling Transient resistance acc. to VDE 0160 / W2 (750 V / 1.3 ms), for all load conditions.

Hold-up time > 27 ms at 196 VAC, 24 V / 5 A

## Efficiency, Reliability etc.\*

Efficiency typ. 88 % (230 VAC, 24 V / 5 A)

Losses typ. 16.3 W (230 VAC, 24 V / 5 A)

MTBF 400.000 h acc. to Siemensnorm SN 29500 (24 V/5 A, 230 VAC, T<sub>amb</sub> = +40 °C)

Life cycle (electrolytics) The unit exclusively uses longlife electrolytics, specified for +105°C (cf. 'The SilverLine', p.2).

## Construction / Mechanics\*

Housing dimensions and Weight

- W x H x D 64 mm x 124 mm x 102 mm (+ DIN rail)
- Free space for above/below 25 mm recommended ventilation left/right 15 mm recommended
- Weight 752g

Design advantages:

- All connection blocks are easy to reach as mounted at the front panel.
- Input and output are strictly apart from each other and so cannot be mixed up (input below, output above).

## Output

Output voltage 24...28 V DC, adjustable by (covered) front panel potentiometer; preset: 24.5 V ± 0.5% Adjustment range guaranteed

Output noise suppression Radiated EMI values below EN50081-1, even when using long, unscreened output cables.

Ambient temperature range T<sub>amb</sub> Operation: -10°C...+70°C (>50°C Derating)  
Storage: -25°C...+85°C

Continuous loading (T <sub>amb</sub> = -10°C...+50°C, convection cooling), also see diagram overleaf. For start at T <sub>amb</sub> <0°C and low input voltage, please contact PULS.	Switch	AC/DCin	I <sub>out</sub> @ 24V		I <sub>out</sub> @ 28V	
			230V	176-264 V ≈	5 A (6 A*)	4.3 A (5.1 A*)
				210-375 V ≈	5 A (6 A*)	4.3 A (5.1 A*)
				150-210 V =	3 A	2.6 A
				100-150 V =	2 A	1.7 A
	115V	85-132 V ≈			5 A (6 A*)	4.3 A (5.1 A*)

Output is protected against short circuit, open circuit and overload \* short-term (< 1 min), at forced cooling even continuous

Derating typ. 3 W/K (at T<sub>amb</sub>=+50°C...+70°C)

Voltage regulation better than 2% V<sub>out</sub> over all

Ripple / Noise < 25 mV<sub>pp</sub> (20 MHz bandw., 50 Ω measurem.)

Overvolt. protection typ. 33 V

Parallel operation yes; current sharing available on request

Power back immunity 34 V

Front panel indicator Green LED, goes out at V<sub>out</sub> < 14 V

\* For further information see data sheets „The SilverLine“, „SilverLine Family Branches“ and mechanics data sheet

## Order information

Order number	Description
SL5.105	
SLZ01	Screw mounting set, two needed per unit

**Start / Overload Behaviour**

Start-up delay	typ. 0.1 s
Rise time	appr. 5-20 ms, depending on load

**Overload Behaviour**

- Special PULS Overload Design – no switch-off, no hiccup if overloaded
- high overload current (up to 1.9 I<sub>Nom</sub>), V<sub>out</sub> is gradually reduced with increasing current (s. diagram on the right)
- 20% power boost – 6 A short-term, at forced cooling even continuous

**Advantages:**

- High short-circuit current, giving large 'start-up window': unit starts reliably even with awkward loads (DC-DC converters, motors).
- No 'sticking' such as can occur with fold-back characteristics
- Secondary fuses operate reliably

**Further information**

Further information, especially about

- EMC
- Connections
- Safety, Approvals
- Mechanics and Mounting

see page 2 of „The SilverLine“ data sheet.

**For detailed dimensions**

see SilverLine mechanics data sheet SL2.5/ SL5/ SL10

**Output characteristic (typ.)**

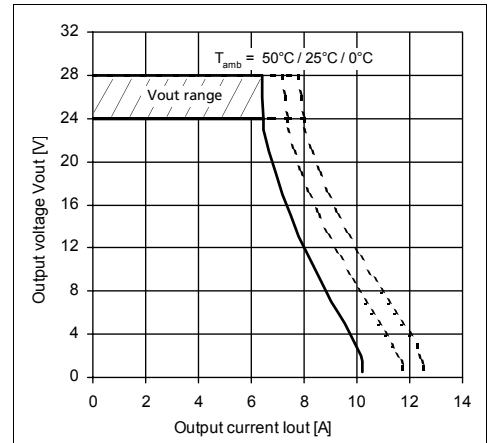

**Output current over input voltage (min., at V<sub>out</sub>=24V)**

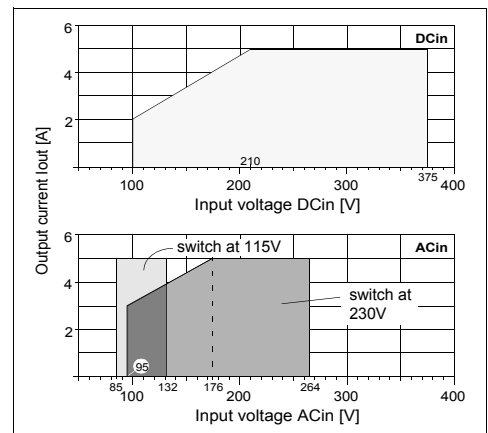

**Efficiency (typ., at V<sub>out</sub>=24V)**

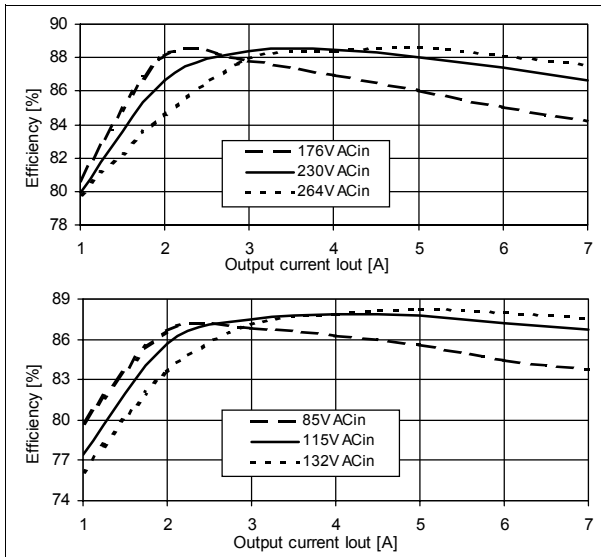

**Hold-up time (min., at V<sub>out</sub>=24V)**

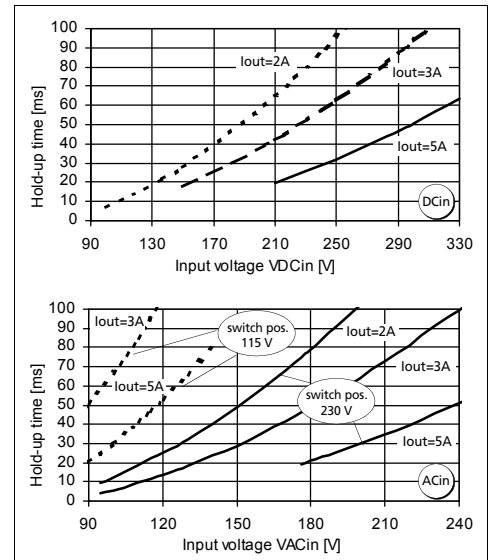

Unless otherwise stated, specifications are valid for AC 230V input voltage, +25°C ambient temperature, and 5 min. run-in time. They are subject to change without prior notice.

**Your partner in power supply:**



Bayerns Best 50  
Czech 100 Best  
EuropeOs 500

**PULS GmbH**  
 Arabellastraße 15  
 D-81925 München  
 Tel.: +49 89 9278-0  
 Fax: +49 89 9278-199  
 www.puls-power.com