

AS-Interface DC/DC converter with 4A

SLAD4.100

PULS

CE
EMC and
Low Volt.
Directive



Data sheet

- Input: DC 24V
- Output: 30.55V / 4A
- AS Interface data decoupling
- For highly demanding industrial applications

Short description

The primary switched mode DIN rail DC/DC converter SLAD4.100 specifically supplies AS Interface® systems with energy. The AS-Interface bus technology allows to connect up to 62 participants to a control and to supply them with energy with a single two-conductor cable. When connecting slaves, the yellow AS-Interface cable offers the high

degree of protection IP67 in conjunction with the insulation displacement. The communication signals of the individual network participants are modulated onto the supply voltage. For this purpose, specific DC/DC converter units with integrated data decoupling are required for AS-Interface systems.

Input

Rated voltage	DC 24V
Input voltage range	18.0-32.4Vdc Continuous operation See Fig.2 14.0-18.0Vdc max. 60 seconds or with derating max. 36.0 Vdc Absolute maximum continuous input voltage with no damage to the DC/DC converter.
Allowed voltage between input and earth (ground)	max. 60Vdc or 42.4Vac
Allowed input ripple voltage	max. 5Vpp, 47Hz-40kHz, the momentary input voltage must always be within the specified limits.
Turn-on voltage	typ. 17.5Vdc Steady-state value
Reverse input polarity protection	Included, unit does not start when input voltage is reversed
Shut down voltage	typ. 14.0Vdc Steady-state value typ. 35Vdc Steady-state value
Input current	typ. 5.6A at 24Vdc input and output 30.55V, 4A
Inrush current	Max. 1.8A peak at -25°C up to +70°C
Inrush energy	Typ. < 1A ² s at -25°C up to +70°C
Start-up delay	typ. 650ms
Rise time	typ. 100ms constant current load 4A typ. 200ms constant current load 4A with external 5mF capacitor
Integrated internal fuse	T10A HBC (not accessible)
External capacitors on the input voltage bus are allowed without any limitations.	

Output

Rated voltage	DC 30.55V +/- 3% (not adjustable)
Rated current	4A
Input / output separation	SELV IEC / EN 60950-1 PELV IEC 60364-4-41, EN 60204-1, IEC 62103 Double or reinforced insulation, Max. allowed voltage between any input pin and ground: 60Vdc or 42.4Vac
Current limitation	> 4.4A
Overload behaviour	Continuous current, see Fig. 3
Short-circuit current	min. 5A , max. 9A
Load regulation	< 250mV Static value, 0A → 4A → 0A
Line regulation	< 5mV Input variations between 18 to 32.4Vdc
Ripple	< 50mVpp (500kHz bandwidth, 50 Ohm meas- urement, ohmic load)
Noise (spikes)	< 100mVpp (20Hz to 20MHz bandwidth, 50 Ohm measurement, ohmic load)
Over-voltage protection	Max. 36V
Operating indicator	Green LED (extinguishes at overload)
Output is protected against short-circuit, open circuit and overload. Use AS-Interface DC/DC converters only together with AS-Interface lines.	

Order information

Order number	Description
SLAD4.100	AS-Interface DC/DC converter
SLZ10	DIN-Rail bracket for S7-300 Simatic-Rail
ZM1.Wall	Wall mounting bracket
ZM11.SIDE	Side mounting bracket

Efficiency, Reliability

Efficiency typ. 90.5% (input 24Vdc, output 4A) , see Fig. 4
 Power dissipation typ. 12.7W (input 24Vdc, output 4A), see Fig. 5

Operating and environmental data

Non-operating temperature range	-40°C up to +85°C
Operating temperature range	-25°C up to +70°C (measured at 25mm below the unit)
Derating	from 60°C 3W/K onwards, power reduction necessary, see Fig. 6
Cooling	natural convection, no forced air-cooling necessary
Over-temperature protection	Yes, output shutdown with automatic restart
Humidity	protect from moisture and condensation
Vibration sinusoidal	2-17.8Hz: ±1.6mm; 17.8-500Hz: 2g; 2 hours / axis; IEC 60068-2-6
Shock	30g 6ms, 20g 11ms 3 bumps / direction, 18 bumps in total; IEC 60068-2-27
Degree of pollution	2 (EN 60950-1)
Overvoltage category	II (IEC 60950-1) III (IEC 62103)

Electromagnetic Compatibility (EMC)

Emissions	EN 61000-6-3 (also includes EN 61000-6-4) Class B (EN 55011, EN 55022)			
Immunity	EN 61000-6-2 (also includes EN 61000-6-1)			
Electrostatic Discharge	EN 61000-4-2	Contact discharge Air discharge	8kV 15kV	Criterion A Criterion A
Electromagnetic RF fields	EN 61000-4-3	80MHz-2.7GHz	10V/m	Criterion A
Fast transients (Burst)	EN 61000-4-4	Input lines Output lines	4kV 2kV	Criterion A Criterion A
Surge voltage on input	EN 61000-4-5	+ → - + / - → chassis ground	1kV 2kV	Criterion A Criterion A
Surge voltage on output	EN 61000-4-5	+ → - + / - → chassis ground	500V 500V	Criterion A Criterion A
Conducted disturbance	EN 61000-4-6	0,15-80MHz	10V	Criterion A

Criteria:

A: DC/DC converter shows normal operation behavior within the defined limits.
 C: Temporary loss of function is possible. DC/DC converter might shut-down and restarts by itself. No damage or hazards will occur to the DC/DC converter.

Schematic

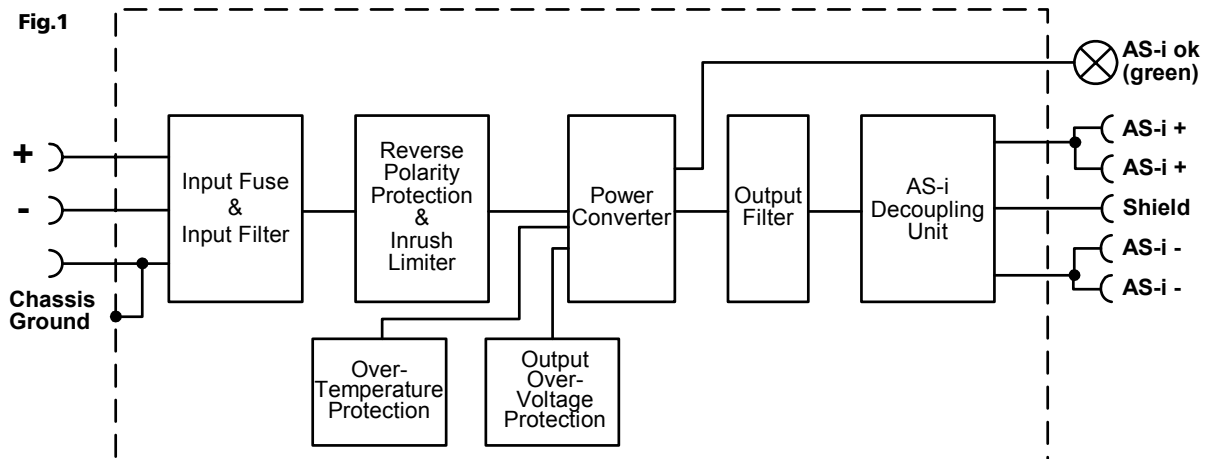

Operating indicators and elements

Plastic slider:

- Mounting: Place the unit onto the DIN-rail and push it downwards and against the lower front edge until it snaps into place.
- Detachment: Push downwards and detach the unit from its DIN-rail mounting bracket.

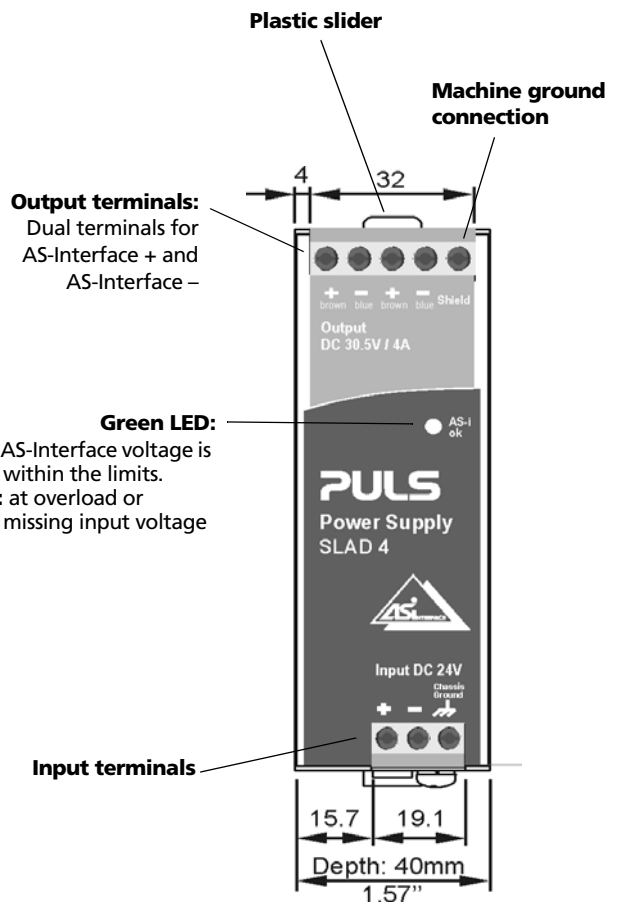
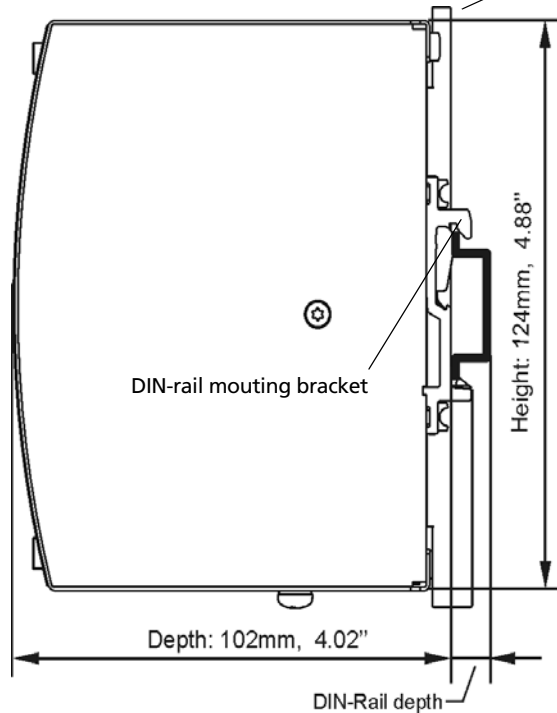

Connectors and terminals

Terminals	Fingertouch-proof terminals with captive screws for 5.5 mm slotted screwdriver or Philips cross-recessed screwdriver No. 2
Position	Easy to reach terminals on the front panel; Input and output clearly separate from each other
Tightening torque	0.8 Nm
Wire gauge	
• flexible cable	0.5-4mm ² (20-10AWG)
• solid cable	0.5-6mm ² (20-10AWG)
Ferrules	Admissible
Stripping length	7mm

Front elements

Input DC 24V	
⊕	+ Input
⊖	- Input
Chassis Ground	Ground this terminal to minimize high-frequency emissions.
Output DC 30.5V /4A	
⊕ brown	Positive AS-Interface output voltage (twice)
⊖ blue	Negative AS-Interface output voltage (twice)
Shield	Connection of machine ground. Functional earth for balancing the AS-Interface output. Connection is recommended for EMC purpose

Construction / Mechanics

Housing	Robust metal housing for built-in installation
Degree of protection	IP20 (EN 60529)
Class of protection	1 (IEC 60536)
Width w	40mm
Height h	124mm
Depth d	102mm (without DIN rail)
Weight	Appr. 500g

Installation notes

External fusing	Not necessary (internal fuse)
Mounting position	Vertical; input below, output above
Free space for cooling	Above / below 25mm recommended Left / right 15mm recommended

Operation without AS-Interface:

This AS-Interface DC/DC converter has an inductive output. When operating without AS-Interface structure (e.g. in a laboratory test) you should connect a 470µF / 35V capacitor between AS-Interface + and AS-Interface - as commercial electronic loads in combination with the data decoupling often tend to oscillate, and the oscillation may exceed the permitted modulation voltage. Otherwise, equipment may be destroyed.

Functional diagrams

Fig. 2 Start behaviour

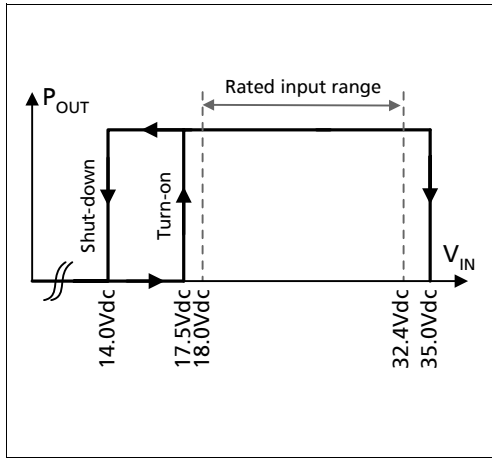

Fig. 3 Output characteristic

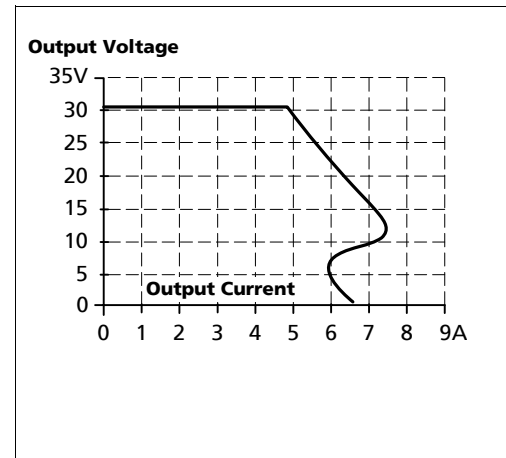

Fig. 4 Efficiency

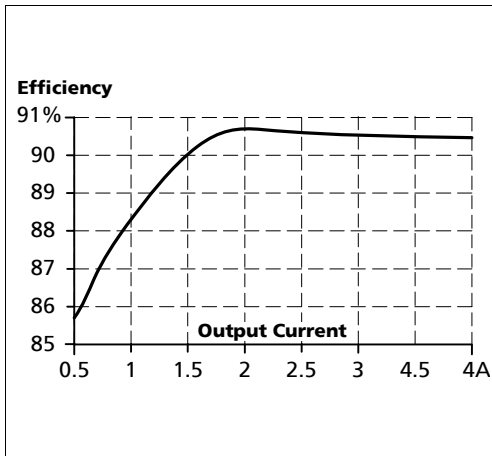

Fig. 5 Losses

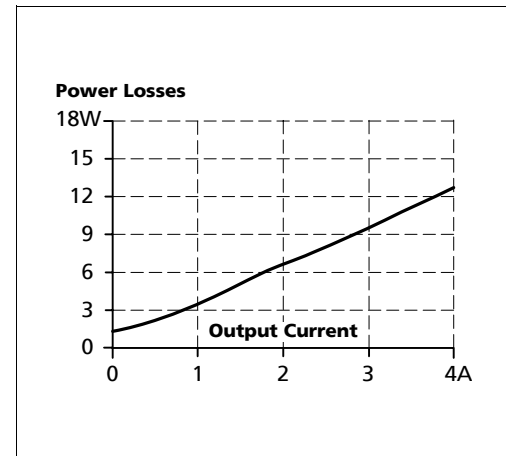
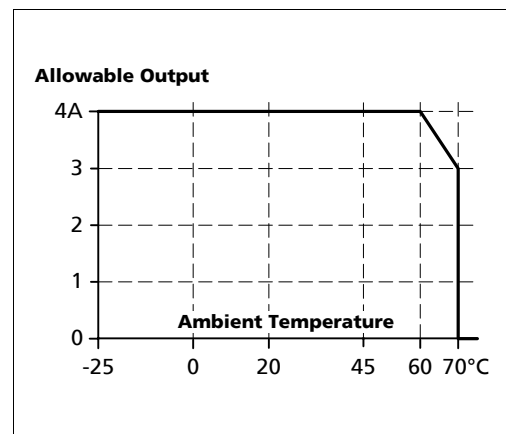

Fig. 6 Derating



Unless otherwise stated, specifications are valid for DC 24V input voltage, +25°C ambient temperature, and 5 min. run-in time. They are subject to change without prior notice.

Your partner in power supply:



Bayerns Best 50
Czech 100 Best
Europe's 500

PULS GmbH
 Arabellastraße 15
 D-81925 München
 Tel.: +49 89 9278-0
 Fax: +49 89 9278-199
 www.puls-power.com