



## SERIES 78B Right Angle Option

### FEATURES

- Easy Access
- SPST Circuitry
- 2-10 and 12 positions available
- Sealed versions available

### APPLICATIONS

Telecommunications, computers and peripherals, instruments and controls.

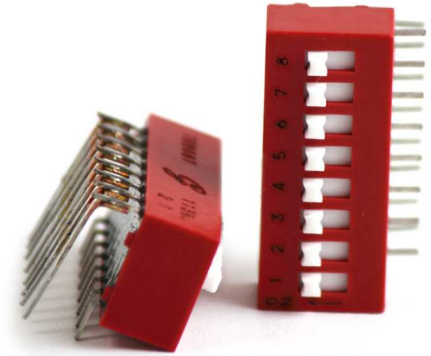

### Series 78B DIMENSIONS in inches (and millimeters)

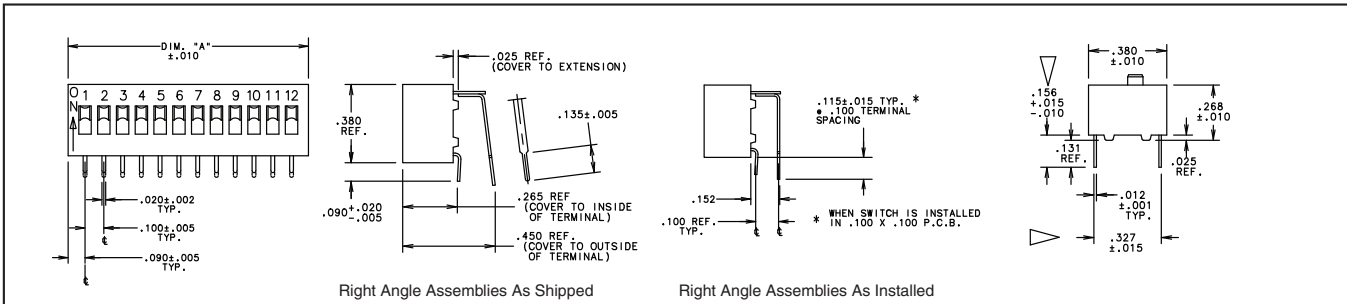

### SPECIFICATIONS

#### Mechanical

**Mechanical Life:** 2,000 operations per switch.

**Operation Temp:** -40°C to + 85°C

**Storage Temp:** -55°C to + 85°C

**Vibration Test:** Per Method 204, Test Condition B, 1 mS opening (10 mS allowed)

**Shock Test:** MIL-STD-202F METHOD 213 Test Condition A, 1ms (10 allowed)

#### Electrical

**Electrical Life:** 10,000 operations per switch 24VDC, 25mA.

**Non-Switching Rating:** 100mA, 50VDC.

**Switching rating:** 150mA, 30VDC;

10mA, 50mVDC

**Contact Resistance:** 30mΩ max. at initial.

**Insulation Resistance:** (at 100VDC) 5,000MΩ min.

**Dielectric Strength:** 750VAC/1 minute.

**Capacitance:** 2pF max.

#### Soldering and Cleaning Process

##### Cleaning tape sealed products:

Passes immersion test using water/detergent. Acceptable solutions include 1-1-1 trichlorethane, freon, (TF, TE, or TMS), isopropyl alcohol, detergent (140°F maximum). Terpene acceptable for Series 90 only. Solutions which are not recommended include acetone, methylene chloride, freon TMC. Pressure wash cleaning processes are not recommended for tape seal switches.

**Wave Soldering:** Recommended solder temperature: 500°F (260°C) max 5 seconds.

**Hand Soldering:** Use a soldering iron of 30 Watts or less, controlled at 608°F (320°C) approximately 2 seconds while applying solder.

**Cleaning:** Tape sealed versions withstand cleaning processes.

#### Materials

**Contact Ball:** Brass with gold plating over nickel

**Terminals:** Brass with gold plating over nickel

**Nonconductive Parts:** Plastic UL94V-0

**Potting Material:** Epoxy

**Shorting Member (Ball):** Brass, gold-plated over nickel barrier.

**Protective Cover:** Polycarbonate.

**Tape Seal:** Polyester film

**Tape Seal Integrity:** Passes gross leak test using 125°C flourinert for 20 seconds minimum. Reference MIL-STD-202, Method 112.

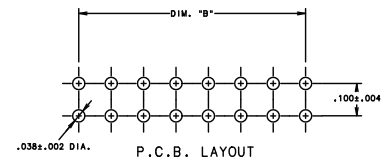
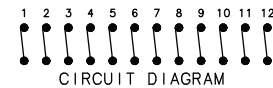

### ORDERING INFORMATION

Series 78B, 78F, 78G, 78H, 78J, 78K, 78RB Styles available as right angle

Number of Positions 2 through 12

RoHS compliant

**78B08SRAT**

Right Angle

S= Top Tape Sealed, Blank=Unsealed

