



CFB400W SERIES

400W WATTS 4:1 INPUT DC-DC CONVERTERS SINGLE OUTPUT

FEATURE

- * 400W Isolated Output
- * Efficiency to 90%
- * Fixed Switching Frequency
- * Input under-voltage Protection
- * Over Temperature Protection
- * Over Voltage/Current Protection
- * Remote ON/OFF
- * Industry Standard Full-Brick Package
- * Fully Isolated 1500VDC
- * Without Tantalum Capacitor Inside



MODEL NUMBER	INPUT VOLTAGE	OUTPUT VOLTAGE	OUTPUT CURRENT		INPUT CURRENT		EFF. (%)	CAPACITIVE LOAD MAX
			MIN.	MAX.	NO LOAD	FULL LOAD		
CFB400W-24S05	9-36VDC	5VDC	0mA	80 A	600mA	19.05A	87.5	10000uF
CFB400W-24S12	9-36VDC	12VDC	0mA	33.3A	120mA	19.36A	86	10000uF
CFB400W-24S24	9-36VDC	24VDC	0mA	16.7A	120mA	19.19A	87	4700uF
CFB400W-24S28	9-36VDC	28VDC	0mA	14.3A	120mA	19.18A	87	4700uF
CFB400W-24S48	9-36VDC	48VDC	0mA	8.3A	120mA	19.19A	86.5	2200uF
CFB400W-48S05	18-75VDC	5VDC	0mA	80 A	300mA	9.36A	89	10000uF
CFB400W-48S12	18-75VDC	12VDC	0mA	33.3A	60mA	9.41A	88.5	10000uF
CFB400W-48S24	18-75VDC	24VDC	0mA	16.7A	60mA	9.28A	90	4700uF
CFB400W-48S28	18-75VDC	28VDC	0mA	14.3A	60mA	9.27A	90	4700uF
CFB400W-48S48	18-75VDC	48VDC	0mA	8.3A	60mA	9.27A	89.5	2200uF

NOTE : 1. Nominal Input Voltage 24,48 VDC

2. The output terminal of 12V,24V,28V&48Vout models required a minimum capacitor 330uF to maintain specified regulation; The output terminal of 05Vout models required a minimum capacitor 680uF to maintain specified regulation.

SPECIFICATIONS

All Specifications Typical At Nominal Line, Full Load, and 25°C Unless Otherwise Noted

INPUT SPECIFICATIONS:

Input Voltage Range.....	24V	9-36V
	48V.....	18-75V
Under voltage lockout	24Vin power up	8.5V
	24Vin power down	7.5V
	48Vin power up	17V
	48Vin power down	15V
Input over voltage protection.....	24Vin Turn off...42V, Turn on...40V	
	48Vin Turn off...83V, Turn on...80V	

Opto isolated Remote ON/OFF

Input Filter PI Type

OUTPUT SPECIFICATIONS:

Voltage Accuracy :	±1.5% max.
Transient Response:25% Step Load Change	<500u sec.
External Trim Adj. Range	80-110%
Load share Accuracy(5).....	±10% at 50% to 100%Full Load
Auxiliary output voltage/current.....	10±3Vdc/20mA max.
Ripple & Noise, 20MHz BW	
5V	40mV RMS max., 100mV pk-pk max
12V	60mV RMS max., 120mV pk-pk max.
24V	100mV RMS max., 240mV pk-pk max.
28V	100mV RMS max., 280mV pk-pk max.
48V	120mV RMS max., 480mV pk-pk max.
Temperature Coefficient.....	±0.03%/°C
Short Circuit Protection.....	Continuous
Line Regulation(1)	±0.2% max.
Load Regulation(2)	±0.5% max.
Over Voltage Protection trip Range, % Vo nom.	115-140%
Current Limit	110% ~150% Nominal Output
Start up time.....	120ms typ.

CASE FB

GENERAL SPECIFICATIONS:

Efficiency.....	See Table
Isolation Voltage	Input/Output..... 1500VDC min.
	Input/Case.....1500VDC min.
	Output/Case..... 1500VDC min.
Isolation Resistance	10 ⁷ ohm min.
Isolation Capacitance.....	TBD Typ
Switching Frequency230kHz, Typ.
Operating Case Temperature	-40°C to 100°C
Storage Temperature	-55°C to +110°C
Thermal Shutdown, Case Temp.	110°C Typ.
Humidity.....	95% RH max. Non condensing
MTBF.....	MIL-HDBK-217F.....T.B.D. hrs
Dimensions	4.60x2.40x0.50 inches(116.8x61.0x12.7 mm)
Case Material	Aluminum Baseplate with Plastic Case
Weight.....	.220 g

NOTE :

1. Measured From High Line to Low Line
2. Measured From Full Load to Zero Load
3. Output Ripple and Noise measured with 10uF tantalum and 1uF Ceramic capacitor across output
4. The output adjustment circuit and trim equations show as figure1 and figure2.
5. An external input capacitor 1000uF for 24Vin or 330uF for 48Vin models are recommended to reduce input ripple voltage.

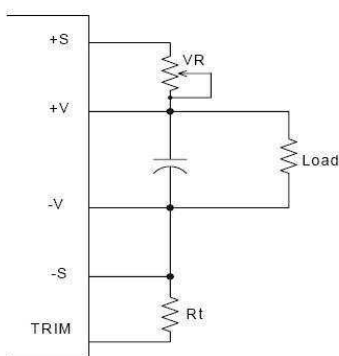
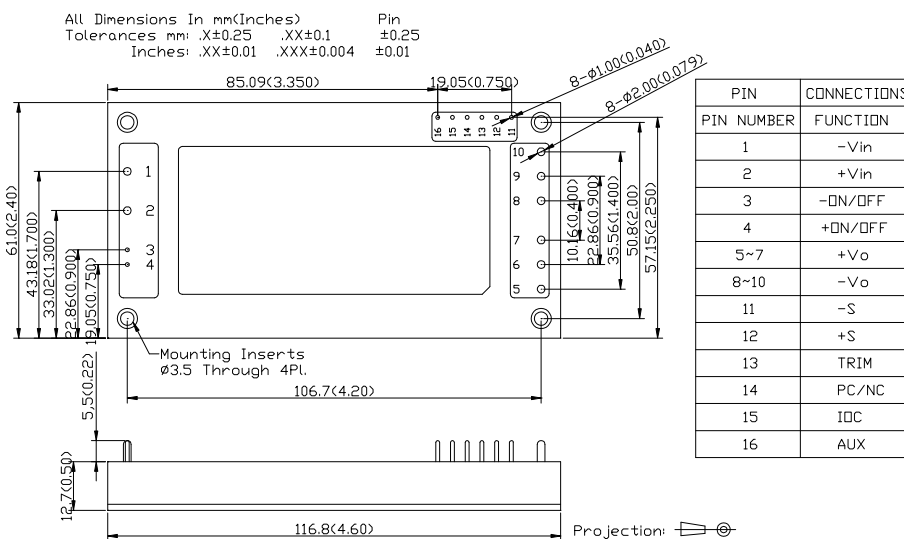

The output voltage can be determined by below equations:

$$V_f = \frac{1.24 \times \left(\frac{R_t \times 33}{R_t + 33} \right)}{7.68 + \frac{R_t \times 33}{R_t + 33}}$$

$$V_{out} = (V_o + V_R) \times V_f$$

Unit: KΩ
 Vo: Nominal Output Voltage

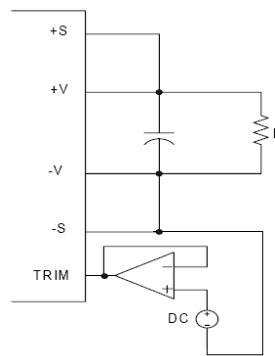

Output Voltage = TRIM Terminal Voltage * Nominal Output Voltage

Fig.2 The schematic of output voltage adjusted by using external DC voltage.

Fig.1 The schematic of output voltage adjusted by using external resistor and/or variable resistor.