

SIP SMT10-05

S E R I E S

10 AMP POL CONVERTERS

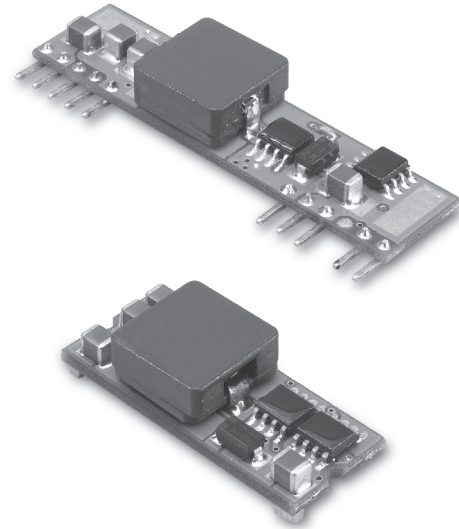

Features

- Non-Isolated POL Converter
- SIP / SMT Package
- Output Current 10AMP
- Input Voltage Range 3.0-5.5VDC
- 300KHz Switching Frequency
- High Efficiency to 95%
- Over Temperature Protection
- Continuous Short Circuit Protection
- Remote On/Off Control
- UL/c-UL 60950 Certified

MODEL NUMBER	INPUT VOLTAGE	OUTPUT VOLTAGE	OUTPUT CURRENT	INPUT CURRENT		% EFF.
				NO LOAD	FULL LOAD	
SIP 10-05S10 SMT10-05S10	3.0-5.5 VDC	1.0VDC	10 A	50mA	2353mA	85
SIP 10-05S12 SMT10-05S12	3.0-5.5 VDC	1.2VDC	10 A	50mA	2791mA	86
SIP 10-05S15 SMT10-05S15	3.0-5.5 VDC	1.5VDC	10 A	50mA	3409mA	88
SIP 10-05S18 SMT10-05S18	3.0-5.5 VDC	1.8VDC	10 A	50mA	4000mA	90
SIP 10-05S20 SMT10-05S20	3.0-5.5 VDC	2.0VDC	10 A	60mA	4396mA	91
SIP 10-05S25 SMT10-05S25	3.0-5.5 VDC	2.5VDC	10 A	60mA	5376mA	93
SIP 10-05S33 SMT10-05S33	4.5-5.5 VDC	3.3VDC	10 A	60mA	6947mA	95

NOTE: 1. Nominal Input Voltage 5.0VDC

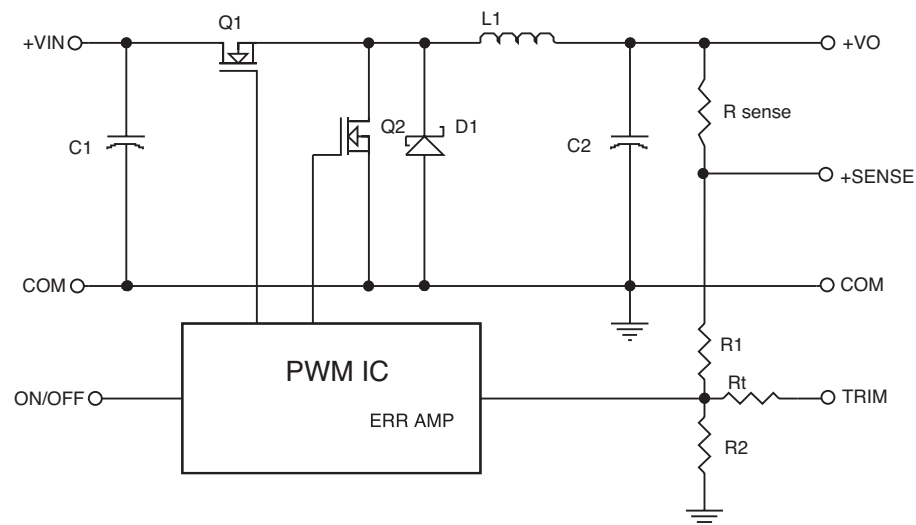

Figure 1. Simplified Schematic

Specifications

INPUT SPECIFICATIONS:

Input Voltage Range.....5V.....3.0 – 5.5V
 5V.....4.5 – 5.5V
 Under Voltage Lock-outPower up2.8V Typ.
 Power down.....2.7V Typ.
 Input Filter Type.....Capacitive
 Positive Remote on/off Control :
 Module ON.....Open Circuit or = Vin
 Module OFF.....< 0.4 Vdc

OUTPUT SPECIFICATIONS:

Voltage Accuracy.....±1.5% max.
 Transient Response :25% Step Load Change.....<200µ sec.
 Ripple and Noise, 20MHz BW³.....20mV rms max.
 50mV pk-pk max.
 Temperature Coefficient.....±0.03%/C max.
 Short Circuit Protection.....Continuous
 Line Regulation¹.....± 0.2% max.
 Load Regulation².....± 0.5% max.
 Capacitive Load, Low ESR.....10000µF max.
 External Trim Adj. Range.....±10%

GENERAL SPECIFICATIONS:

Efficiency.....See Table
 Isolation Voltage.....Non-isolation
 Switching Frequency300KHz Typ.
 Over Temperature Protection120°C Typ.
 Operating Ambient Temperature Range.....-40°C to +85°C
 Power Derating Curvesee Figure 2,3
 Storage Temperature Range-55°C to +125°C
 Dimensions:
 SIP Package: 2.00 x 0.50 x 0.33 inches (50.8 x 12.7 x 8.3 mm)
 SMT Package: 1.30 x 0.530 x 0.366 inches (33.0 x 12.46 x 9.3 mm)
 Structure.....Non-potted With Open Frame Type
 Weight.....6.8g

SIP10-05SXX (Vin=5V) Derating Curve

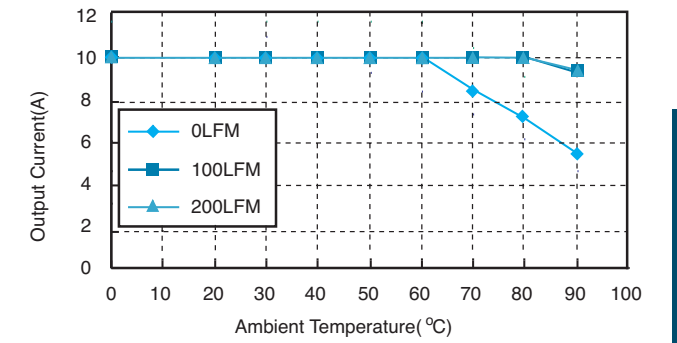

Figure 2. Typical Power De-rating for 5V IN

SMT10-05SXX (Vin=5V) Derating Curve

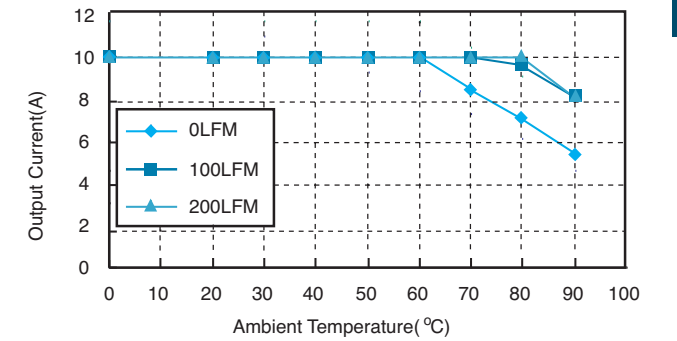

Figure 3. Typical Power De-rating for 5V IN

NOTE:

1. Measured From High Line to Low Line
2. Measured From Full Load to Zero Load
3. The output noise is measured with 10µf tantalum capacitor and 1µf ceramic capacitor across output.
4. The Input Terminal Recommend to Parallel With 100µF Capacitor ESR<20mΩ to Reduce The Input Ripple Voltage
5. Suffix "N" to the Model Number with Negative Logic Remote on/off
 Model ON.....Open Circuit or < 0.4VDC
 Module OFF.....>+2.8VDC to Vin

Mechanical Specification

All Dimensions In Inches(mm)
 Tolerance Inches: x.xx= ±0.02, x.xxx= ±0.010
 Millimeters: x.x= ±0.5, x.xx= ±0.25

SIP Packages

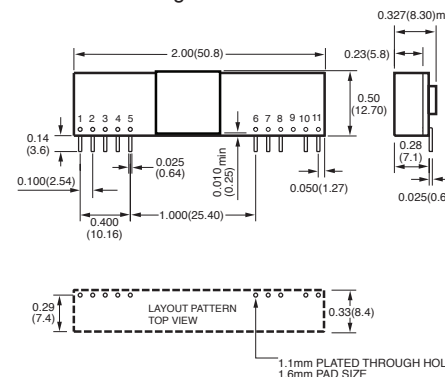

SMT Packages BOTTOM VIEW OF BOARD

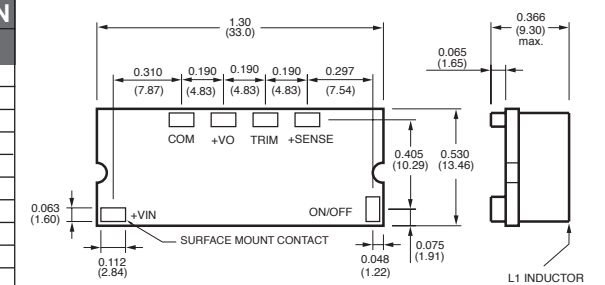

Pin	Function
1	+Output
2	+Output
3	+Sense
4	+Output
5	Common
6	Common
7	+V Input
8	+V Input
9	No Pin
10	Trim
11	On/Off Control

All Specifications Typical At Nominal Line, Full Load and 25°C Unless Otherwise Noted.