

SIP SMT10W-12

S E R I E S

10 AMP POL CONVERTERS

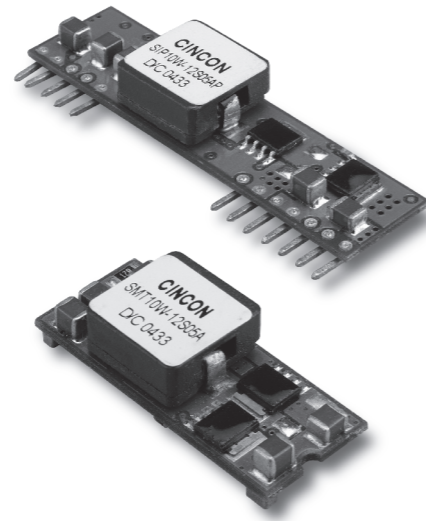

Features

- Non-Isolated POL Converter
- SIP / SMT Package
- Output Current 10AMP
- Input Voltage Range 6-14VDC
- Output Voltage Range 0.7525-5VDC
- 300KHz Switching Frequency
- High Efficiency to 95%
- Over Temperature Protection
- Continuous Short Circuit Protection
- Remote On/Off Control
- Output Voltage Sequencing
- Power Good Signal
- UL/c-UL 60950 Certified

MODEL NUMBER	INPUT VOLTAGE	OUTPUT VOLTAGE	OUTPUT CURRENT	INPUT CURRENT		% EFF.
				NO LOAD	FULL LOAD	
SIP10W-12S05A	6.0-14 VDC	0.7525VDC	10A	40mA	762mA	82
	6.0-14 VDC	1.2VDC	10A	40mA	1149mA	87
	6.0-14 VDC	1.5VDC	10A	50mA	1404mA	89
	6.0-14 VDC	1.8VDC	10A	50mA	1666mA	90
SMT10W-12S05A	6.0-14 VDC	2.0VDC	10A	60mA	1832mA	91
	6.0-14 VDC	2.5VDC	10A	65mA	2264mA	92
	6.0-14 VDC	3.3VDC	10A	75mA	2956mA	93
	6.5-14 VDC	5.0VDC	10A	95mA	4386mA	95

NOTE: 1. Nominal Input Voltage 12VDC

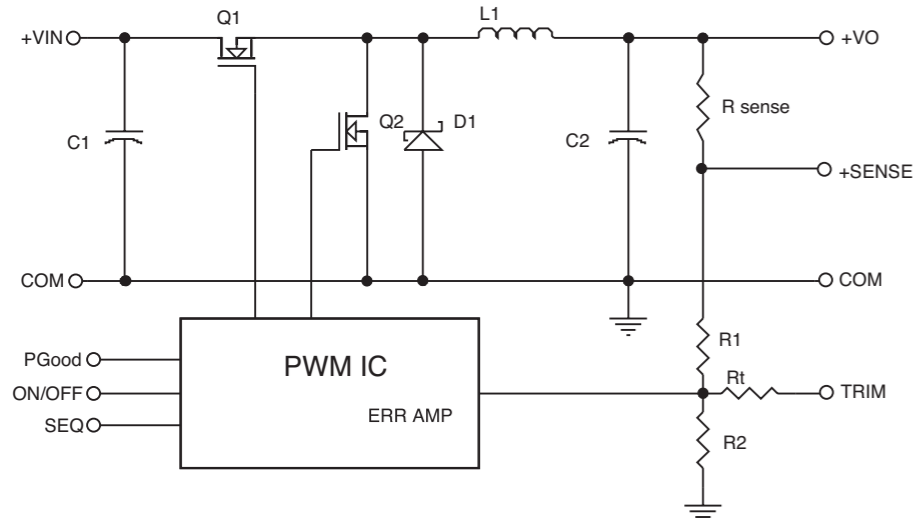

Figure 1. Simplified Schematic

Vo, set (V)	Rtrim (KΩ)
0.7525	Open
1.2	22.46
1.5	13.05
1.8	9.024
2.0	7.417
2.5	5.009
3.3	3.122
5.0	1.472

Table 1. External Resistor Values for programming output voltage

Specifications

INPUT SPECIFICATIONS:

Input Voltage Range.....	12V.....	6.0 – 14V
	12V.....	6.5 – 14V
Under Voltage Lock-out	Power up	5.0V Typ.
	Power down.....	4.0V Typ.
Input Filter Type.....		Capacitive
Positive Remote on/off Control :		
Module ON.....		Open Circuit or = Vin
Module OFF.....		< 0.4 Vdc

OUTPUT SPECIFICATIONS:

Voltage Accuracy.....		±1.5% max.
Transient Response :25% Step Load Change.....		<200µ sec.
Ripple and Noise, 20MHz BW ³		30mV rms max.
		75mV pk-pk max.
Temperature Coefficient.....		±0.03%/C max.
Short Circuit Protection.....		Continuous
Line Regulation ¹		± 0.2% max.
Load Regulation ²		± 0.5% max.
External Trim Adj. Range (see Table 1).....		Vo=0.75-5.0Vdc
Sequencing Slew Rate Capability (dV _{seq} /dt).....		0.1-1.0V/msec
Sequencing Delay Time.....		10msec min.
Tracking Accuracy.....	Power up.....	200mV max.
	Power down.....	400mV max.
Capacitive Load, Low ESR.....		8000µF max.
Power Good Signal Asserted Logic High.....		Vo=90%-110%Vo,nom

GENERAL SPECIFICATIONS:

Efficiency.....		See Table
Isolation Voltage.....		Non-isolation
Switching Frequency		300KHz Typ.
Over Temperature Protection		130°C Typ.
Operating Ambient Temperature Range.....		-40°C to +85°C
Power Derating Curve		see Figure 2,3
Storage Temperature Range		-55°C to +125°C
Dimensions:		
	SIP Package:	2.00 x 0.510 x 0.327 inches (50.8 x 12.95 x 8.30 mm)
	SMT Package:	1.30 x 0.530 x 0.346 inches (33.0 x 13.46 x 8.8 mm)
Structure.....		Non-potted With Open Frame Type
Weight.....		8.5g

SIP10W-12S05A Vo=3.3V Derating Curve

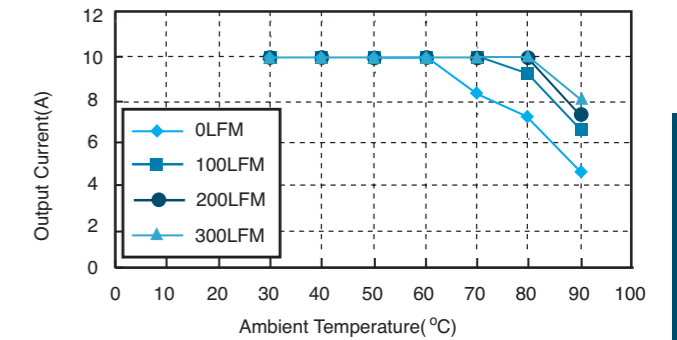

Figure 2. Typical Power De-rating for 12V IN

SMT10W-12S05A Vo=3.3V Derating Curve

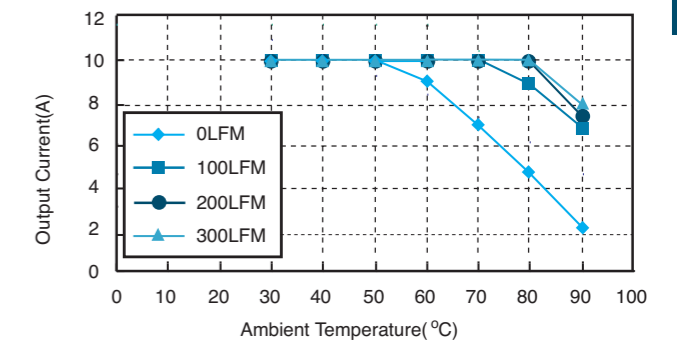

Figure 3. Typical Power De-rating for 12V IN

NOTE:

1. Measured From High Line to Low Line, Vo,set=3.3Vdc
2. Measured From Full Load to Zero Load, Vo,set=3.3Vdc
3. The output noise is measured with 10µf tantalum capacitor and 1µf ceramic capacitor across output.
4. The Input Terminal Recommend to Parallel With 100µF Capacitor ESR<100mΩ to Reduce The Input Ripple Voltage
5. Suffix "N" to the Model Number with Negative Logic Remote on/off
Module ON..... Open Circuit or < 0.4VDC
Module OFF..... >+2.8VDC to Vin
6. Suffix "P" to the Model Number with Power Good function.

Mechanical Specification

All Dimensions In Inches(mm)
Tolerance Inches: x.xx= ±0.02, x.xxx= ±0.010
Millimeters: x.x= ±0.5, x.xx= ±0.25

SIP Packages

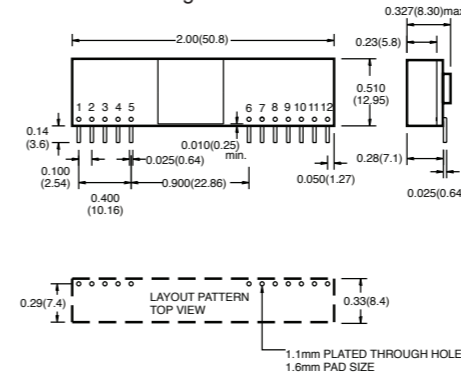

PIN CONNECTION

Pin	Function
1	+Output
2	+Output
3	+Sense
4	+Output
5	Common
6	No Pin / PGood
7	Common
8	+V Input
9	+V Input
10	Sequency
11	Trim
12	On/Off Control

SMT Packages

BOTTOM VIEW OF BOARD

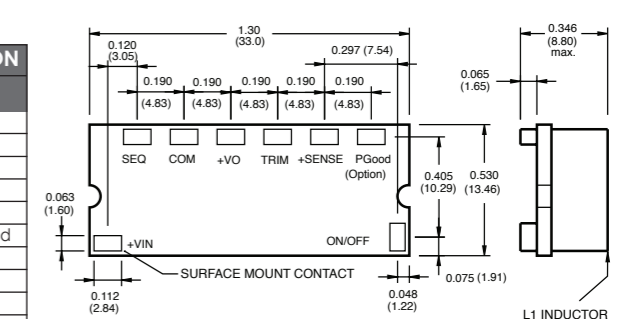

All Specifications Typical At Nominal Line, Full Load and 25°C Unless Otherwise Noted.