

HEAT SINKS

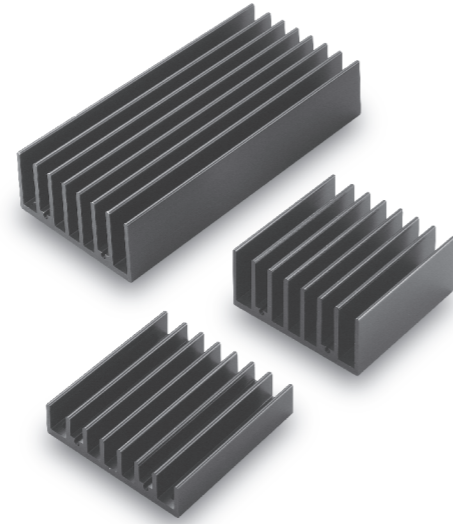

HALF BRICK CASE HEATSINK

All Dimensions In mm

Vertical Fins
P/N: G6620400201
Model No. :M-C308

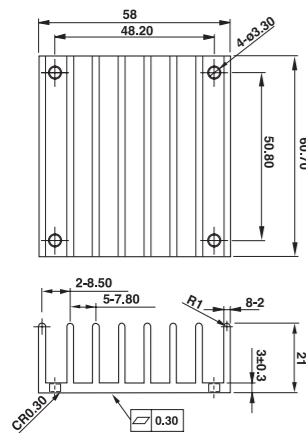

Rca: 3.9°C/W (typ.), At natural convection
1.74°C/W (typ.), At 100LFM
1.33°C/W (typ.), At 200LFM
1.12°C/W (typ.), At 300LFM
0.97°C/W (typ.), At 400LFM

Horizontal Fins
P/N: G6610120402
Model No. :M-C091

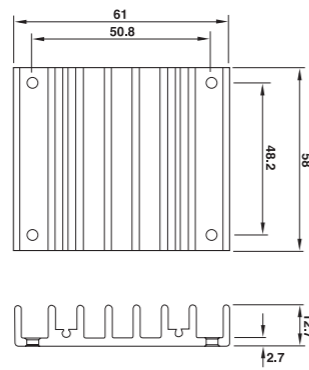

Rca: 4.7°C/W (typ.), At natural convection
2.89°C/W (typ.), At 100LFM
2.30°C/W (typ.), At 200LFM
1.88°C/W (typ.), At 300LFM
1.59°C/W (typ.), At 400LFM

Horizontal Fins
P/N: G6610130402
Model No. :M-C092

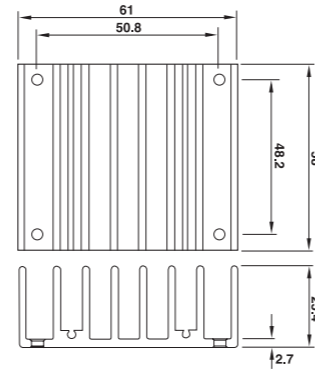

Rca: 3°C/W (typ.), At natural convection
1.44°C/W (typ.), At 100LFM
1.17°C/W (typ.), At 200LFM
1.04°C/W (typ.), At 300LFM
0.95°C/W (typ.), At 400LFM

QUARTER BRICK CASE HEATSINK

Vertical Fins

All Dimensions In mm

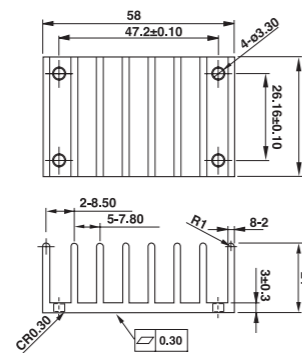

Rca: 4.78°C/W (typ.), At natural convection
2.44°C/W (typ.), At 100LFM
2.06°C/W (typ.), At 200LFM
1.76°C/W (typ.), At 300LFM
1.58°C/W (typ.), At 400LFM

FULL BRICK HEATSINK

Horizontal Fins
P/N: G6620090204
Model No. :M-B012

All Dimensions In mm

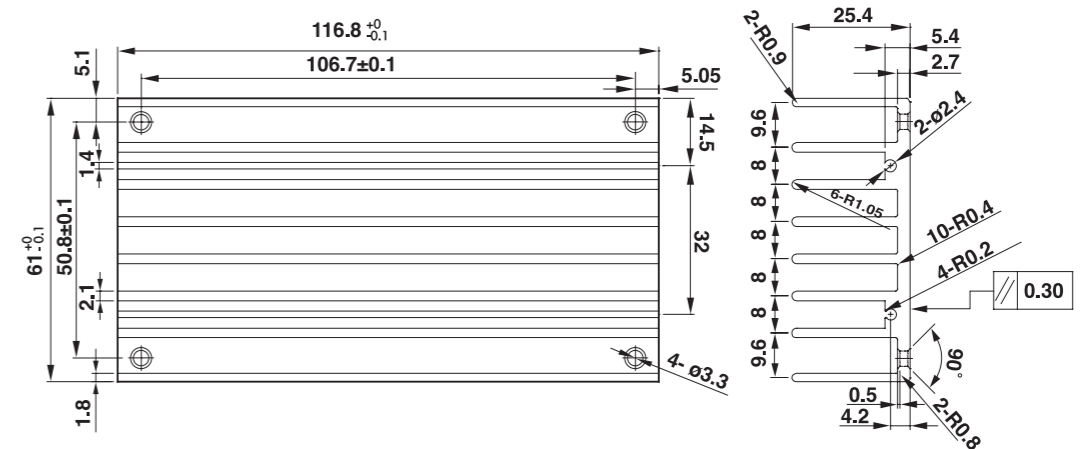

Thermal pad: SR60x115.8x0.23 (G6135013070)
Screw SMP+SW M3x8L (75A1300322)
Thermal Resistance: 2.07°C/W (typ.), At natural convection

HALF BRICK HEATSINK ASSEMBLY

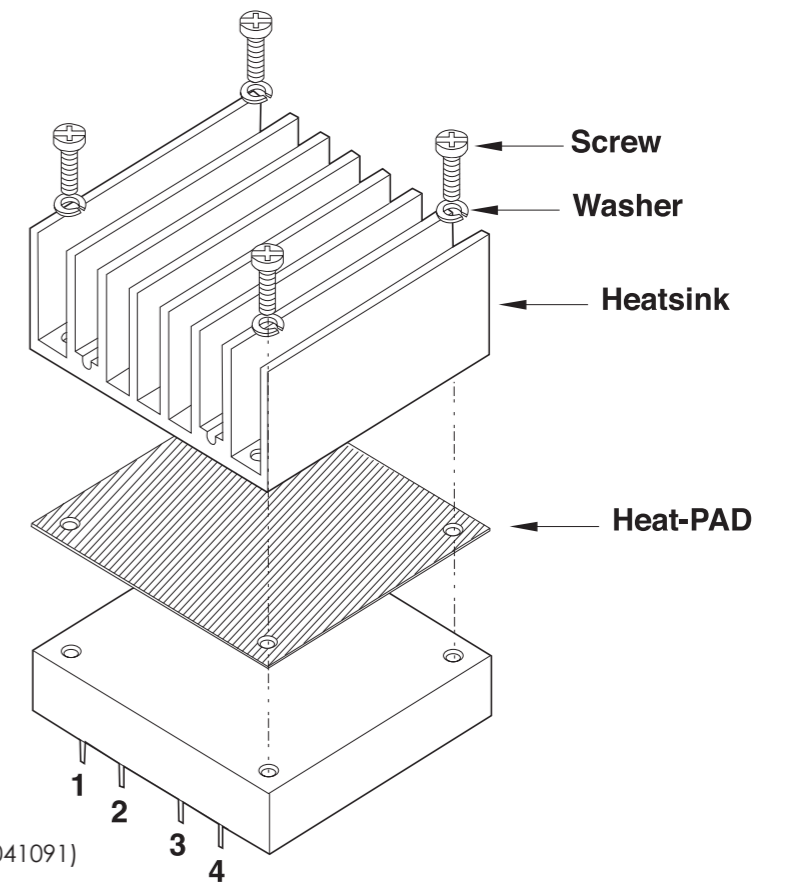

Heat Sink: M-C308 (G6620400201)
M-C091 (G6610120402)
M-C092 (G6610130402)
Thermal Pad: SZ56.9x60x0.25mm (G6135041091)
Screw: SMP+SW M3x8L (G75A1300322)