

## Standard Probes & Assemblies

# MOISTURE RESISTANT TEMPERATURE SENSOR

### Features:

- Can accommodate a wide array of thermistor sensing elements
- Wide operating temperature range: -40°C to 125°C
- Excellent for freeze/thaw applications in refrigeration, HVAC and appliance industries
- Standard cable length is 10 ft.
- Standard housing is .25" OD Nickel-plated Brass

### Description:

ATP's moisture resistant design for thermistor temperature assemblies provides a solution for the primary cause of sensor failures in high moisture environments. Many temperature sensing applications in HVAC, appliance and other industries require that the sensor be mounted in or near areas that are subject to moisture due to condensation. Thermistors can be seriously affected by long term exposure to moisture. Over time, this condition will cause low or very erratic resistances due to sensor instability. In high moisture environments, it's imperative that the internal construction of the probe assembly is capable of sealing off all moisture paths to the thermistor.

This design from ATP provides for an excellent moisture seal between all parts of the system and deters water from entering the assembly. A unique internal construction is utilized as well as a special combination of wire and epoxies to provide a moisture resistant seal to the outside environment and, thus protecting the thermistor sensing element.

Any number of different thermistor curves and values can be accommodated as well as a broad range of housing and wire styles. Terminations can be provided utilizing various connector pins or lugs. Please contact the factory for specific design or application information or the availability of options.



Moisture Resistant Thermistor Sensor

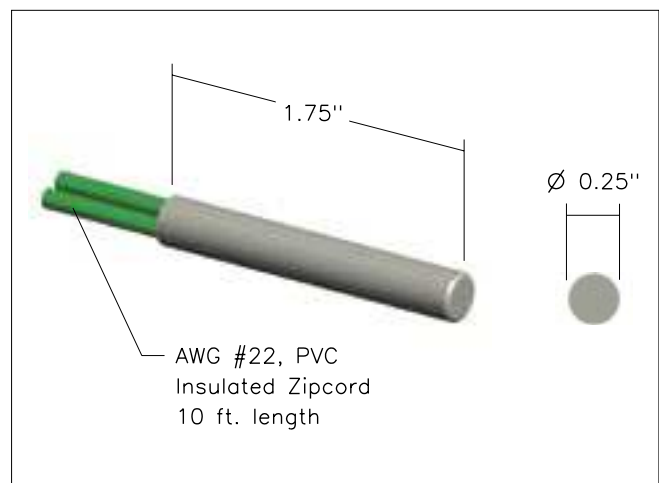

### Ordering Information

ATP Part Number	R <sub>25</sub> (Ω)	Material Curve	Wire Color
A2253BT22P0	2,252	Z	Orange
A3003BT22P0	3,000	Z	Purple
A5003BT22P0	5,000	Z	Blue
A1004BT22P0	10,000	Z	Black

Standard temperature accuracy is ±0.2°C from 0°C to 70°C. Other resistance values and accuracies available upon request.

Resistance versus temperature information for material curve Z can be found on page 57.