

Wideband Microwave Amplifier

AVA-183A+

50Ω

5 to 18 GHz



CASE STYLE: DQ849

The Big Deal

- Surface Mount Amplifier up to 18 GHz
- Integrated matching, DC Blocks and bias circuits
- Superior Value

Product Overview

The AVA-183A+ is a surface mount, microwave amplifier and fully integrated gain block up to 18 GHz. It is packaged in Mini-Circuits industry standard 3x3 mm MCLP package, which provides excellent RF and thermal performance. The AVA-183A+ integrates the entire matching network with the majority of the bias circuit inside the package, reducing the need for complicated external circuits. This approach makes the AVA-183A+ extremely flexible and enables simple, straightforward use.

Key Features

Feature	Advantages
Wideband, 5 to 18 GHz	Broad frequency range supports a wide array of applications from microwave radio and radar , to military communications and countermeasures.
Excellent Gain Flatness	Typical ± 1.2 dB gain flatness across the entire frequency range minimizes the need for external equalizer networks making it a great fit for instrumentation and EW applications.
High Isolation	With reverse isolation of 31-42 dB (17-23 dB directivity), the AVA-183A+ is an excellent choice for buffering broadband circuits. It is an ideal LO driver amplifier and provides designers system flexibility and margin when integrating cascaded RF components.
Single +5V Supply	<ul style="list-style-type: none">• No hassle associated with amplifiers using dual supply; such as power supply sequencing.• Integrated output bias-tee, simplifies layout & reduces cost.
Manufacturability	MSL1 and ESD Class1A (HBM) ratings minimize special handling on production lines.

Notes

- A. Performance and quality attributes and conditions not expressly stated in this specification document are intended to be excluded and do not form a part of this specification document.
B. Electrical specifications and performance data contained in this specification document are based on Mini-Circuit's applicable established test performance criteria and measurement instructions.
C. The parts covered by this specification document are subject to Mini-Circuits standard limited warranty and terms and conditions (collectively, "Standard Terms"); Purchasers of this part are entitled to the rights and benefits contained therein. For a full statement of the Standard Terms and the exclusive rights and remedies thereunder, please visit Mini-Circuits' website at www.minicircuits.com/MCLStore/terms.jsp



Product Features

- Gain, 13.8 dB typ. & Flatness, ± 1.2 dB
- Output Power, up to +19.0 dBm typ.
- Excellent isolation, 36 dB typ. at 12 GHz
- Single Positive Supply Voltage, 5.0V
- Integrated DC blocks, Bias-Tee & Microwave bypass capacitor
- Unconditionally Stable
- Aqueous washable; 3mm x 3mm SMT package



AVA-183A+

CASE STYLE: DQ849
PRICE: \$6.95 ea. QTY. (10)

+RoHS Compliant

The +Suffix identifies RoHS Compliance. See our web site for RoHS Compliance methodologies and qualifications

Typical Applications

- Military EW and Radar
- DBS
- Wideband Isolation amplifier
- Microwave point-to-point radios
- Satellite systems

General Description

The AVA-183A+ is a wideband monolithic amplifier with outstanding gain flatness up to 18 GHz. It is manufactured using PHEMT technology and is unconditionally stable. Its outstanding isolation enables it to be used as a wideband isolation amplifier or buffer amplifier in a variety of microwave systems.

simplified schematic and pad description

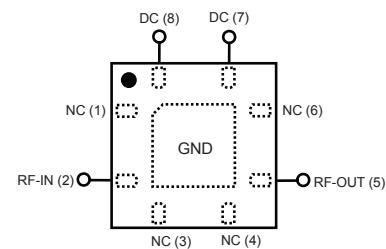
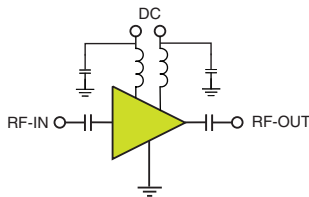

Function	Pad Number	Description (See Application Circuit, Fig. 2)
RF-IN	2	RF input pad
RF-OUT	5	RF output pad
DC	8(V_{D1}), 7(V_{D2})	DC power supply
GND	paddle in center of bottom	Connected to ground
NOT USED	1,3,4,6	No internal connection; recommended use: per PCB Layout PL-328

Notes

- A. Performance and quality attributes and conditions not expressly stated in this specification document are intended to be excluded and do not form a part of this specification document.
 B. Electrical specifications and performance data contained in this specification document are based on Mini-Circuit's applicable established test performance criteria and measurement instructions.
 C. The parts covered by this specification document are subject to Mini-Circuits' standard limited warranty and terms and conditions (collectively, "Standard Terms"); Purchasers of this part are entitled to the rights and benefits contained therein. For a full statement of the Standard Terms and the exclusive rights and remedies thereunder, please visit Mini-Circuits' website at www.minicircuits.com/MCLStore/terms.jsp



Electrical Specifications⁽¹⁾ at 25°C, Z₀=50Ω, (refer to characterization circuit, Fig.1)

Parameter	Condition (GHz)	Min.	Typ.	Max.	Units
Frequency Range		5.0		18.0	GHz
DC Voltage (V _{D1} , V _{D2})			5.0		V
DC Current (I _{D1} +I _{D2})		104	131	166	mA
Gain	5.0		12.9		dB
	8.0	12.0	14.7		
	10.0	12.0	14.0		
	12.0		13.4		
	14.0		13.1		
	16.0		13.6		
	18.0	10.8	12.4		
Input Return Loss	5.0		10.4		dB
	8.0		17.0		
	10.0		11.0		
	12.0		11.0		
	14.0		11.0		
	16.0		11.0		
	18.0		7.5		
Output Return Loss	5.0		8.0		dB
	8.0		18.0		
	10.0		14.0		
	12.0		11.0		
	14.0		10.6		
	16.0		11.2		
	18.0		11.8		
Output IP ₃ ⁽²⁾	5.0		32.2		dBm
	8.0		29.0		
	10.0		27.7		
	12.0		26.3		
	14.0		25.1		
	16.0		24.3		
	18.0		24.4		
Output Power @ 1 dB compression	5.0		17.6		dBm
	8.0		18.0		
	10.0	16.0	19.0		
	12.0		19.0		
	14.0		19.9		
	16.0		19.6		
	18.0		18.7		
Noise Figure	5.0		7.4		dB
	8.0		4.3		
	10.0		4.5		
	12.0		4.8		
	14.0		5.1		
	16.0		5.1		
	18.0		6.0		
Directivity (Isolation-Gain)	12		23.1		dB
DC Current Variation vs. Temperature ⁽³⁾			0.046		mA/°C
Thermal Resistance			61		°C/W

Absolute Maximum Ratings⁽⁴⁾

Parameter	Ratings
Operating Temperature ⁽⁵⁾	-40°C to 85°C
Storage Temperature	-55°C to 100°C
Channel Temperature	150°C
DC Voltage (Pad 7,8)	5.5 V
DC Voltage (Pads 2, 5)	10 V
Power Dissipation	980 mW
DC Current (Pad 7+8)	180 mA
Input Power (CW)	20 dBm

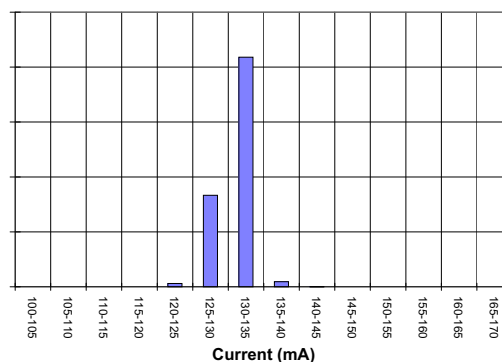

⁽¹⁾ Measured on Mini-Circuits Characterization test fixture TB-547-2+ See Characterization Test Circuit (Fig. 1)

⁽²⁾ At P_{out}=9dBm/100

⁽³⁾ (Current at 85°C - Current at -45°C)/130

⁽⁴⁾ Permanent damage may occur if any of these limits are exceeded.

⁽⁵⁾ These maximum ratings are not intended for continuous normal operation.

⁽⁶⁾ Defined with reference to ground pad temperature.

Notes

- A. Performance and quality attributes and conditions not expressly stated in this specification document are intended to be excluded and do not form a part of this specification document.
 B. Electrical specifications and performance data contained in this specification document are based on Mini-Circuit's applicable established test performance criteria and measurement instructions.
 C. The parts covered by this specification document are subject to Mini-Circuits standard limited warranty and terms and conditions (collectively, "Standard Terms"); Purchasers of this part are entitled to the rights and benefits contained therein. For a full statement of the Standard Terms and the exclusive rights and remedies thereunder, please visit Mini-Circuits' website at www.minicircuits.com/MCLStore/terms.jsp

Intermodulation and IP3 vs. Frequency and Output Power

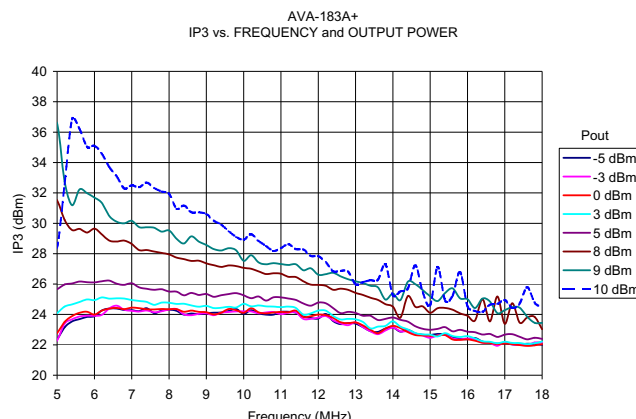
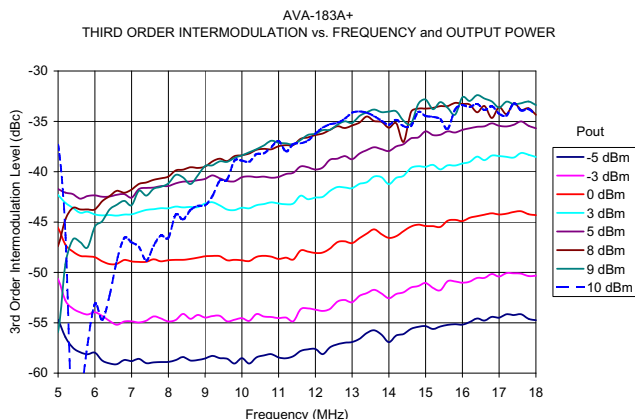

Characterization Test Circuit

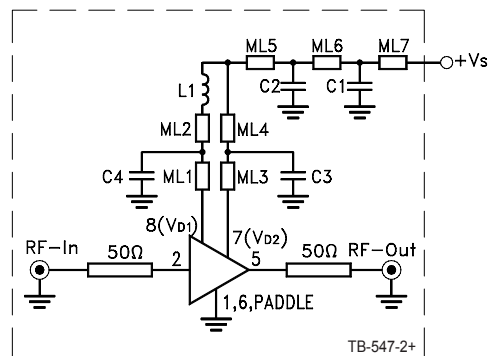

C1=5.6pF, 0402 (NPO) ML1-ML7 are short microstrip lines Refer to 98-PL-328
 C2=18pF, 0402 (NPO)
 C3=0.001μF, 0402 (NPO)
 C4=0.1 μF, 0402 (X7R)
 L1=3.3nH, 0805 (wire wound)

Recommended Application Circuit

(refer to evaluation board for PCB Layout and component values)

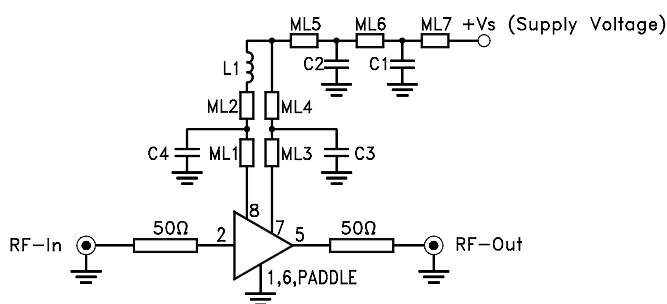

Fig 2. Recommended Application Circuit

Fig 1. Block Diagram of Test Circuit used for characterization. (DUT soldered on Mini-Circuits Characterization Test Board TB-547-2+) Gain, Output power at 1dB compression (P1dB), Noise Figure, Output IP3 (OIP3) are measured using Agilent's N5242A PNA-X microwave network analyzer.

Conditions:

1. Gain: Pin=-25 dBm
2. Output IP3 (OIP3): Two tones, spaced 1 MHz apart, 9 dBm/tone at output.
3. Vs adjusted for 5.0V at device (V_{D1} and V_{D2}), compensating loss of bias lines.

Product Marking



← black body
 ← model family designation

Notes

- A. Performance and quality attributes and conditions not expressly stated in this specification document are intended to be excluded and do not form a part of this specification document.
- B. Electrical specifications and performance data contained in this specification document are based on Mini-Circuits' applicable established test performance criteria and measurement instructions.
- C. The parts covered by this specification document are subject to Mini-Circuits standard limited warranty and terms and conditions (collectively, "Standard Terms"); Purchasers of this part are entitled to the rights and benefits contained therein. For a full statement of the Standard Terms and the exclusive rights and remedies thereunder, please visit Mini-Circuits' website at www.minicircuits.com/MCLStore/terms.jsp



Additional Detailed Technical Information	
<i>additional information is available on our dash board. To access this information click here</i>	
Performance Data	Data Table
	Swept Graphs
	S-Parameter (S2P Files) Data Set (.zip file)
Case Style	DQ849 <i>Plastic package, exposed paddle, lead finish: tin silver/nickel</i>
Tape & Reel Standard quantities available on reel	F104 <i>7" reels with 10, 20, 50, 100, 200, 500, 1000 or 2000 devices.</i>
Suggested Layout for PCB Design	PL-328
Evaluation Board	TB-547-2+
Environmental Ratings	ENV08T1

ESD Rating

Human Body Model (HBM): 1A (250 to <500V) in accordance with ANSI/ESD STM 5.1 - 2001

Machine Model (MM): M1 (25V) in accordance with ANSI/ESD STM5.2-1999

MSL Rating

Moisture Sensitivity: MSL1 in accordance with IPC/JEDEC J-STD-020D

MSL Test Flow Chart

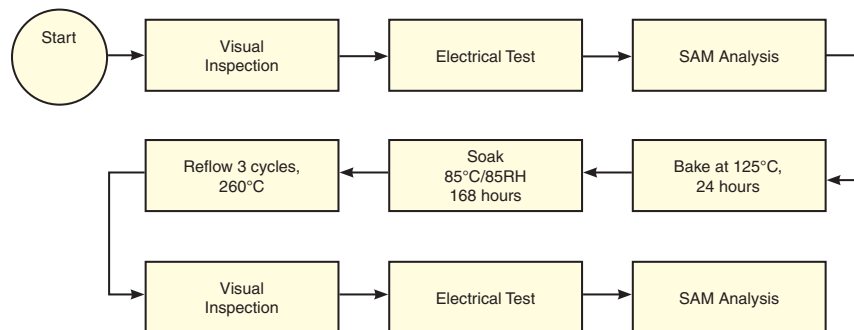

Notes

- A. Performance and quality attributes and conditions not expressly stated in this specification document are intended to be excluded and do not form a part of this specification document.
 B. Electrical specifications and performance data contained in this specification document are based on Mini-Circuit's applicable established test performance criteria and measurement instructions.
 C. The parts covered by this specification document are subject to Mini-Circuits standard limited warranty and terms and conditions (collectively, "Standard Terms"); Purchasers of this part are entitled to the rights and benefits contained therein. For a full statement of the Standard Terms and the exclusive rights and remedies thereunder, please visit Mini-Circuits' website at www.minicircuits.com/MCLStore/terms.jsp