

High Directivity

Monolithic Amplifier

0.5-2.5 GHz

Product Features

- 3V & 5V operation
- no external biasing circuit required
- internal DC blocking at RF input and output
- high directivity, 20 dB typ.
- wide bandwidth, 0.5 to 2.5 GHz
- low noise figure, 5.5 dB typ.
- output power, up to +18.2 dBm typ.
- low cost



VNA-25+

CASE STYLE: XX211-1
PRICE: \$2.50 ea. QTY. (20)

Typical Applications

- buffer amplifier
- cellular
- PCN

+RoHS Compliant

The +Suffix identifies RoHS Compliance. See our web site for RoHS Compliance methodologies and qualifications

General Description

VNA-25+ is a wideband amplifier offering high dynamic range. It has repeatable performance from lot to lot. It is enclosed in an 8-lead SOIC package. VNA-25+ is fabricated using GaAs MESFET technology. Expected MTBF at 85°C case temperature is 40,000 years at 2.8V, 2,000 at 5V.

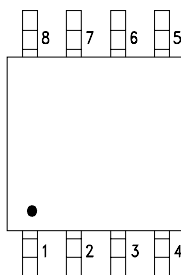

Pin Description

Function	Pin Number	Description
RF IN	3	RF input pin.
RF OUT	6	RF output pin.
DC	1	Bias pin
GND	2,4,5,7,8	Connections to ground. Use via holes as shown in "Suggested Layout for PCB Design" to reduce ground path inductance for best performance.

Notes

- A. Performance and quality attributes and conditions not expressly stated in this specification document are intended to be excluded and do not form a part of this specification document.
B. Electrical specifications and performance data contained in this specification document are based on Mini-Circuit's applicable established test performance criteria and measurement instructions.
C. The parts covered by this specification document are subject to Mini-Circuits standard limited warranty and terms and conditions (collectively, "Standard Terms"); Purchasers of this part are entitled to the rights and benefits contained therein. For a full statement of the Standard Terms and the exclusive rights and remedies thereunder, please visit Mini-Circuits' website at www.minicircuits.com/MCLStore/terms.jsp



Electrical Specifications at 25°C

Parameter	Min.	Typ.		Max.	Units	
Frequency Range	0.5			2.5	GHz	
at DC Volts	5.0	5.0	2.8	5.0	V	
Gain	16	f=0.5 GHz	15.5	14.5	dB	
		f=1.0 GHz	18.0	16.7		
		f=1.5 GHz	18.6	17.4		
		f=2.0 GHz	17.8	17		
		f=2.5 GHz	16	15.5		
Input Return Loss	f=0.75 to 2.5 GHz		14	14	dB	
Output Return Loss	f=0.75 to 2.5 GHz		12.5	12.5	dB	
Output Power @ 1 dB compression	f=0.5 to 2.5 GHz		18.2	12	dBm	
Output IP3	f=0.5 to 2.5 GHz		29	24	dBm	
Noise Figure	f=0.5 to 2.5 GHz		5.5	5.5	dB	
Directivity (Isolation-Gain)	f=0.5 to 2.5 GHz		18-24	16-25	dB	
DC Current			85	80	105	mA
Thermal Resistance, junction-to-case ¹			125		°C/W	

Absolute Maximum Ratings

Parameter	Ratings
Operating Temperature	-40°C to 85°C
Storage Temperature	-55°C to 150°C
DC Voltage	+7V, -1.0V reverse
Power Dissipation	1000mW
Input Power	10dBm

Note: Permanent damage may occur if any of these limits are exceeded.
 These ratings are not intended for continuous normal operation.
¹Case is defined as ground leads.

Notes

- A. Performance and quality attributes and conditions not expressly stated in this specification document are intended to be excluded and do not form a part of this specification document.
- B. Electrical specifications and performance data contained in this specification document are based on Mini-Circuit's applicable established test performance criteria and measurement instructions.
- C. The parts covered by this specification document are subject to Mini-Circuits standard limited warranty and terms and conditions (collectively, "Standard Terms"); Purchasers of this part are entitled to the rights and benefits contained therein. For a full statement of the Standard Terms and the exclusive rights and remedies thereunder, please visit Mini-Circuits' website at www.minicircuits.com/MCLStore/terms.jsp



Product Marking

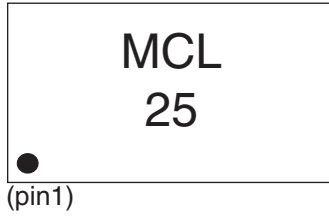

Additional Detailed Technical Information

Additional information is available on our web site. To access this information enter the model number on our web site home page.

Performance data, graphs, s-parameter data set (.zip file)

Case Style: XX211-1

VNA-25+: Plastic molded, 8-lead SOIC, lead finish: Tin Plate

Tape & Reel: F16

7" reels with 20, 50, 100, 200, 500 or 1K devices.
13" reel with 2.5K devices.

Suggested Layout for PCB Design: PL-077

Evaluation Board: TB-01

Environmental Ratings: ENV08T1

Recommended Application Circuit

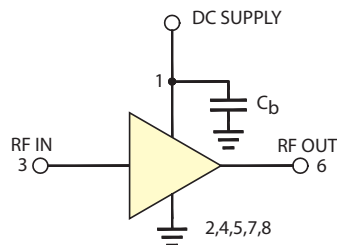

$C_b = 100\text{pF to } 10\text{ nF}$
Test Board includes case, connectors, and components (in bold) soldered to PCB

Notes

- A. Performance and quality attributes and conditions not expressly stated in this specification document are intended to be excluded and do not form a part of this specification document.
- B. Electrical specifications and performance data contained in this specification document are based on Mini-Circuit's applicable established test performance criteria and measurement instructions.
- C. The parts covered by this specification document are subject to Mini-Circuits standard limited warranty and terms and conditions (collectively, "Standard Terms"); Purchasers of this part are entitled to the rights and benefits contained therein. For a full statement of the Standard Terms and the exclusive rights and remedies thereunder, please visit Mini-Circuits' website at www.minicircuits.com/MCLStore/terms.jsp



ESD Rating

Human Body Model (HBM): Class 1A (250 v to < 500 v) in accordance with ANSI/ESD STM 5.1 - 2001

Charged Device Model (CDM): Class III (500 v to 1000v) in accordance with JESD22-C101A

MSL Rating

Moisture Sensitivity: MSL1 in accordance with IPC/JEDECJ-STD-020C

No.	Test Required	Condition	Standard	Quantity
1	Visual Inspection	Low Power Microscope Magnification 40x	MIP-IN-0003 (MCT spec)	10 units
2	Electrical Test	Room Temperature	SCD (MCL spec)	10 units
3	SAM Analysis	Less than 10% growth in term of delamination	J-Std-020C (Jedec Standard)	10 units
4	Moisture Sensitivity Level 1	Bake at 125°C for 24 hours Soak at 85°C/85%RH for 168 hours Reflow 3 cycles at 260°C peak	J-Std-020C (Jedec Standard)	10 units

MSL Test Flow Chart

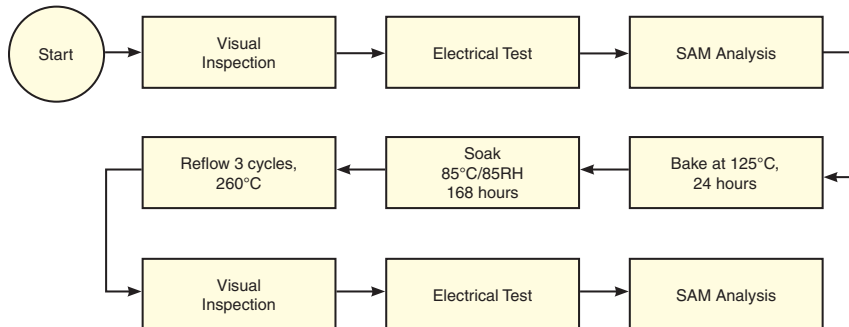

Notes

- A. Performance and quality attributes and conditions not expressly stated in this specification document are intended to be excluded and do not form a part of this specification document.
- B. Electrical specifications and performance data contained in this specification document are based on Mini-Circuit's applicable established test performance criteria and measurement instructions.
- C. The parts covered by this specification document are subject to Mini-Circuits standard limited warranty and terms and conditions (collectively, "Standard Terms"); Purchasers of this part are entitled to the rights and benefits contained therein. For a full statement of the Standard Terms and the exclusive rights and remedies thereunder, please visit Mini-Circuits' website at www.minicircuits.com/MCLStore/terms.jsp

