

High Power Amplifier

ZHL-20W-13SW+

50Ω 20W 20 to 1000 MHz

Features

- High power, 20 Watt
- Protected against overheat - shuts off automatically at about +100°C case temperature
- Protected against over voltage - shuts off automatically at about +29V(excluding fan)
- Excellent gain flatness, ±1.2 dB typ.
- RF built-in switch with TTL/CMOS control
- Class A amplifier
- Protected by US patent 7,348,854

Applications

- VHF/UHF transmitters
- Defense
- Amateur radio, FM, TV



Model No.	ZHL-20W-13SW+ ▲ZHL-20W-13SWX+
Case Style	CP1683
Connectors	SMA
Price (Qty.)	\$1445.00 ea. (1-9) \$1370.00 ea. (1-9)

+RoHS Compliant

The +Suffix identifies RoHS Compliance. See our web site for RoHS Compliance methodologies and qualifications

Product Description

ZHL-20W-13SW+ is a Class-A, high dynamic range, unconditionally stable amplifier with automatic over temperature and over voltage protection. It features a built-in RF switch with TTL/CMOS control.

Electrical Specifications at 25°C

Parameter	Condition (MHz)	ZHL-20W-13SW+ ▲ZHL-20W-13SWX+			Units
		Min.	Typ.	Max.	
Frequency Range		20		1000	MHz
Gain	20 - 1000	46	50	55	dB
Gain Flatness	20 - 1000	—		±1.8	dB
Output Power at 1dB compression	20 - 1000	+39	+41	—	dBm
Output Power at 3 dB compression	20 - 1000	+40	+43	—	dBm
Noise Figure	20 - 1000	—	3.5	—	dB
Output third order intercept point	20 - 1000	—	+50	—	dBm
Input VSWR	20 - 1000	—	1.7	—	:1
Output VSWR	20 - 1000	—	2.5	—	:1
DC Supply Voltage		—	24*	—	V
Supply Current		—	—	2.8	A
SW Low (V_{IL}), RF ON		—	—	0.5	V
SW High (V_{IH}), RF OFF		2.7	5.0	—	V
SW Current		—	5	—	μA
Rise Time (SW ON to 90% RF)		—	—	50	μsec
Fall Time (SW OFF to 10% RF)		—	—	5	μsec

* Recommended Operating Voltage.

▲ Heat sink and fan not included. Alternative heat sinking and heat removal must be provided by the user to limit maximum base-plate temperature to 85°C, in order to ensure proper performance. For reference, this requires thermal resistance of user's external heat sink to be 0.3°C/W max.

Maximum Ratings

Parameter	Ratings
Operating Temperature	-20°C to 65°C
Storage Temperature	-55°C to 100°C
Base Plate Temperature	85°C
DC Voltage	28V
SW Voltage	10V
Input RF Power ¹ (no damage)	-3 dBm

Permanent damage may occur if any of these limits are exceeded.

1. At nominal output load, 24V nominal supply voltage. Amplifier can withstand a full mismatch (short or open) across all phases at the RF output for peak envelope power (PEP) not exceeding the output power at 1 dB compression (or +41dBm typ. at output) [Refer to application note AN-60-037 for PEP calculation].

Notes

- Performance and quality attributes and conditions not expressly stated in this specification document are intended to be excluded and do not form a part of this specification document.
- Electrical specifications and performance data contained in this specification document are based on Mini-Circuit's applicable established test performance criteria and measurement instructions.
- The parts covered by this specification document are subject to Mini-Circuits standard limited warranty and terms and conditions (collectively, "Standard Terms"); Purchasers of this part are entitled to the rights and benefits contained therein. For a full statement of the Standard Terms and the exclusive rights and remedies thereunder, please visit Mini-Circuits' website at www.minicircuits.com/MCLStore/terms.jsp



Outline Drawing for models with heatsink

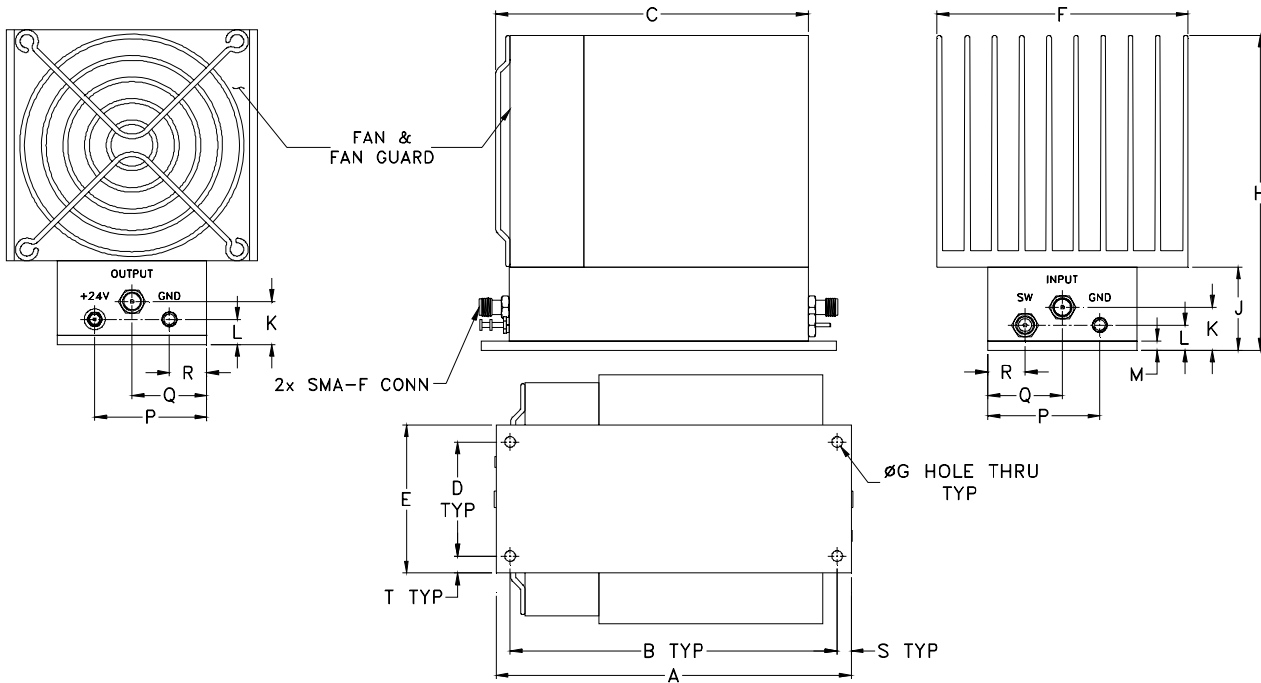

Outline Drawing for models without heatsink

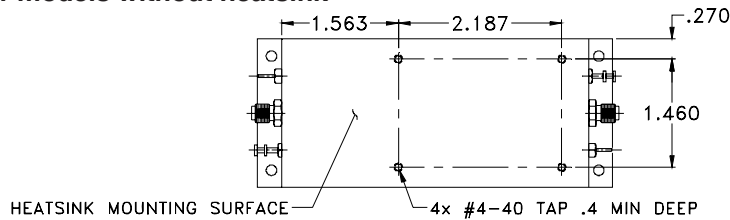

Outline Dimensions (inch/mm)

A	B	C	D	E	F	G	H	J	K	L	M	P	Q	R	S	T	wt
4.75	4.375	4.18	1.540	2.00	3.36	.144	4.25	1.12	0.58	0.34	.13	1.50	1.00	.50	.19	.23	grams*
120.65	111.13	106.17	39.12	50.80	85.34	3.66	107.95	28.45	14.73	8.636	3.30	38.10	25.40	12.70	4.83	5.84	750

*290 grams without heatsink

Notes

- Performance and quality attributes and conditions not expressly stated in this specification document are intended to be excluded and do not form a part of this specification document.
- Electrical specifications and performance data contained in this specification document are based on Mini-Circuit's applicable established test performance criteria and measurement instructions.
- The parts covered by this specification document are subject to Mini-Circuits standard limited warranty and terms and conditions (collectively, "Standard Terms"); Purchasers of this part are entitled to the rights and benefits contained therein. For a full statement of the Standard Terms and the exclusive rights and remedies thereunder, please visit Mini-Circuits' website at www.minicircuits.com/MCLStore/terms.jsp



FREQUENCY (MHz)	GAIN (dB)		VSWR (:1)		NOISE FIGURE (dB)	POUT at 1 dB COMPR. (dBm)		IP3 (dBm)
	SW Low or Open ON	SW High OFF	IN	OUT		24V	24V	
20.00	49.96	-20.25	1.39	1.06	3.90	41.42	53.41	
50.00	49.84	-16.58	1.40	1.15	3.76	41.88	57.17	
100.00	50.04	-10.82	1.37	1.42	3.64	42.35	56.07	
150.00	50.35	-8.63	1.34	1.50	3.65	42.48	55.19	
200.00	50.83	-6.18	1.28	1.41	3.69	42.40	53.84	
250.00	51.02	-4.97	1.26	1.29	3.75	42.42	52.46	
300.00	50.82	-3.82	1.29	1.51	3.78	42.35	52.10	
350.00	50.41	-3.39	1.34	1.89	3.84	41.83	51.92	
400.00	49.76	-2.83	1.40	2.61	3.85	41.28	51.59	
450.00	49.48	-2.34	1.41	3.09	3.81	41.25	52.00	
500.00	49.52	-1.13	1.37	3.59	3.85	41.18	52.60	
550.00	49.91	0.03	1.32	3.75	3.85	41.12	51.63	
600.00	50.92	2.06	1.18	3.66	3.89	40.88	50.91	
650.00	51.69	3.33	1.07	3.49	3.86	41.07	50.19	
700.00	51.98	4.21	1.09	3.39	3.81	41.59	49.83	
750.00	51.57	4.13	1.16	3.47	3.85	41.75	49.60	
800.00	50.64	3.93	1.20	3.57	3.84	41.88	50.23	
850.00	50.31	4.18	1.19	3.52	3.82	41.94	50.44	
900.00	50.55	5.44	1.15	3.37	3.80	41.80	50.84	
950.00	51.01	6.55	1.11	3.21	3.88	41.84	50.17	
1000.00	50.52	6.87	1.09	2.78	3.89	40.96	50.28	

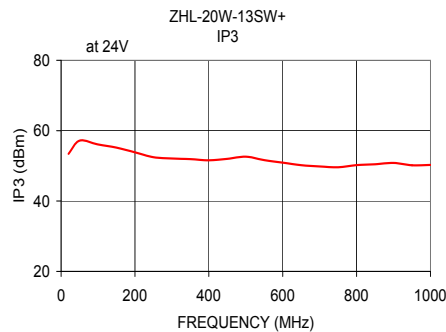
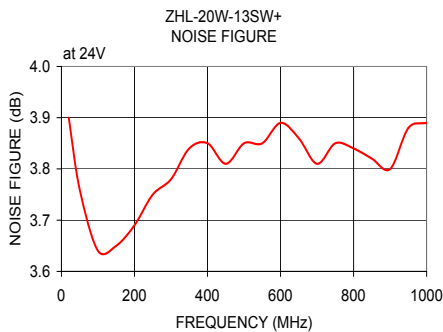
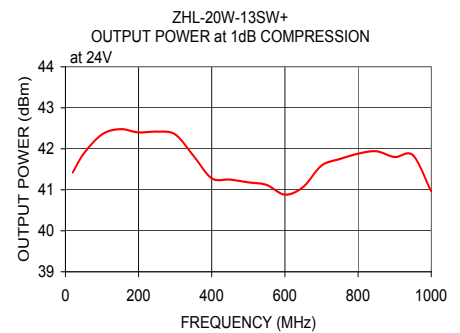
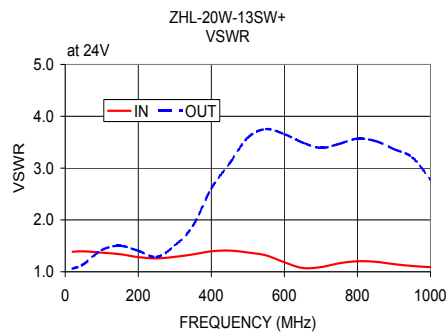
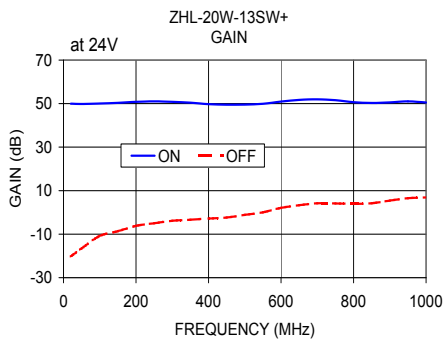

Notes

- A. Performance and quality attributes and conditions not expressly stated in this specification document are intended to be excluded and do not form a part of this specification document.
- B. Electrical specifications and performance data contained in this specification document are based on Mini-Circuit's applicable established test performance criteria and measurement instructions.
- C. The parts covered by this specification document are subject to Mini-Circuits standard limited warranty and terms and conditions (collectively, "Standard Terms"); Purchasers of this part are entitled to the rights and benefits contained therein. For a full statement of the Standard Terms and the exclusive rights and remedies thereunder, please visit Mini-Circuits' website at www.minicircuits.com/WCLStore/terms.jsp

