

LTCC Bandpass Filter

BFCN-7350+

50Ω 7150 to 7550 MHz



CASE STYLE: FV1206-4

The Big Deal

- Small size 3.2mm x 1.6mm
- Pass band (7150-7550 MHz)
- Low Insertion Loss (1.8 dB typical)
- Sharp rejection peaks close to stop band

Product Overview

The BFCN-7350+ LTCC Band Pass Filter is constructed with 5 layers in order to achieve a miniature size and high repeatability of performance. Wrap-around terminations minimize variations in performance due to parasitics. Covering 7350 MHz \pm 200 MHz, these units offer low insertion loss and good rejection at the band reject edges.

Key Features

Feature	Advantages
Small Size (3.20mm x1.6 mm)	Allows for high layout density of circuit boards, while minimizing affects of parasitics.
Rejection peaks close to pass band	Provides good rejection of signals close to the pass band, for improved system performance.
Wrap around termination	Provides excellent solderability and easy visual inspection capability.
LTCC construction	Provides a rugged package that is well suited for tough environments including high humidity and high temperature extremes.

Notes

- A. Performance and quality attributes and conditions not expressly stated in this specification document are intended to be excluded and do not form a part of this specification document.
B. Electrical specifications and performance data contained in this specification document are based on Mini-Circuit's applicable established test performance criteria and measurement instructions.
C. The parts covered by this specification document are subject to Mini-Circuits standard limited warranty and terms and conditions (collectively, "Standard Terms"); Purchasers of this part are entitled to the rights and benefits contained therein. For a full statement of the Standard Terms and the exclusive rights and remedies thereunder, please visit Mini-Circuits' website at www.minicircuits.com/MCLStore/terms.jsp



Bandpass Filter

50Ω 7150 to 7550 MHz

BFCN-7350+



CASE STYLE: FV1206-4
PRICE: \$3.95 ea. QTY (20)

+RoHS Compliant

The +Suffix identifies RoHS Compliance. See our web site for RoHS Compliance methodologies and qualifications



Available Tape and Reel at no extra cost

Reel Size	Devices/Reel
7"	20, 50, 100, 200, 500, 1000, 3000

Maximum Ratings

Operating Temperature	-55°C to 100°C
Storage Temperature	-55°C to 100°C
RF Power Input*	2W max. at 25°C

*Passband rating, derate linearly to 0.5W at 100°C ambient
Permanent damage may occur if any of these limits are exceeded.

Pin Connections

RF IN	1
RF OUT	3
GROUND	2,4

Product Marking: 43

Outline Drawing

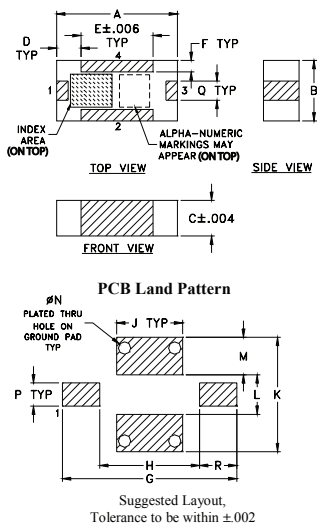

Outline Dimensions (inch/mm)

A	B	C	D	E	F	G	H	J
.126	.063	.037	.026	.075	.012	.182	.104	.069
3.20	1.60	0.94	0.66	1.91	0.30	4.62	2.64	1.75
K	L	M	N	P	Q	R		wt
.119	.041	.039	.013	.024	.020	.039		grams
3.02	1.04	0.99	0.33	0.61	0.51	0.99		.020

Demo Board MCL P/N: TB-518+ Suggested PCB Layout (PL-305)

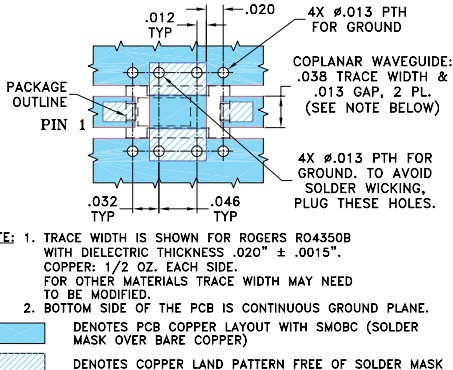

Features

- Small size
- Temperature stable
- Hermetically sealed
- LTCC construction

Applications

- Harmonic Rejection
- Transmitters / Receivers

Electrical Specifications¹ at 25°C

Parameter	F#	Frequency (MHz)	Min.	Typ.	Max.	Unit	
Pass Band	Center Frequency	—	—	7350	—	MHz	
	Insertion Loss	F1-F2	7150-7550	—	1.8	3.5	dB
Stop Band, Lower	VSWR	F1-F2	7150-7550	—	1.3	—	:1
	Insertion Loss	DC-F3	DC-6325	—	15	—	dB
Stop Band, Upper	VSWR	DC-F3	DC-6325	—	30	—	:1
	Insertion Loss	F4-F5	8700-14000	—	15	—	dB
VSWR	F4-F5	8700-14000	—	30	—	:1	

1. Measured on Mini-Circuits Characterization Test Board TB-518+.

Typical Frequency Response

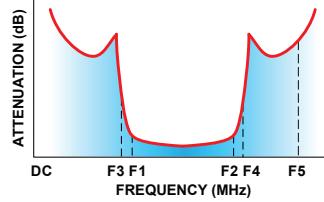

Functional Schematic

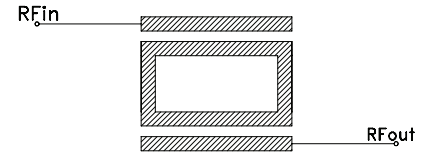

Typical Performance Data at 25°C

Frequency (MHz)	Insertion Loss (dB)	VSWR (:1)
100.00	46.71	1737.18
800.00	28.74	579.06
1500.00	23.56	217.15
2550.00	19.77	102.19
5000.00	17.29	34.75
6050.00	21.72	42.38
6750.00	7.32	32.79
7100.00	1.84	5.72
7300.00	1.81	1.96
8000.00	6.33	4.24
9000.00	24.85	22.58
10050.00	14.90	23.49
12050.00	17.49	10.02
13050.00	20.61	7.70
14050.00	20.66	6.76

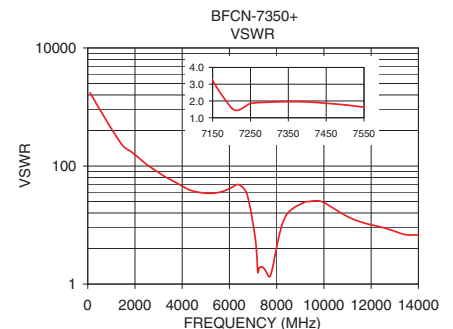
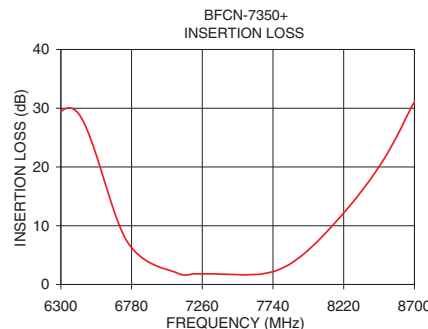
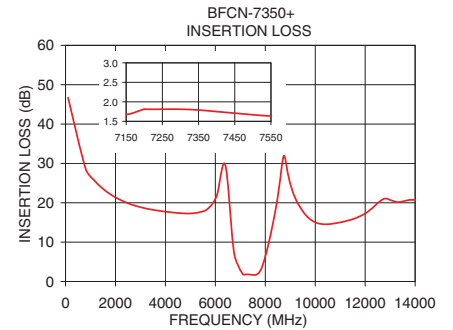

Notes

- Performance and quality attributes and conditions not expressly stated in this specification document are intended to be excluded and do not form a part of this specification document.
- Electrical specifications and performance data contained in this specification document are based on Mini-Circuit's applicable established test performance criteria and measurement instructions.
- The parts covered by this specification document are subject to Mini-Circuits standard limited warranty and terms and conditions (collectively, "Standard Terms"); Purchasers of this part are entitled to the rights and benefits contained therein. For a full statement of the Standard Terms and the exclusive rights and remedies thereunder, please visit Mini-Circuits' website at www.minicircuits.com/MCLStore/terms.jsp