

LTCC High Pass Filter

HFCN-1100+

50Ω 1500 to 3900 MHz

The Big Deal

- Small size 3.2mm x 1.6mm
- Pass band (1500-3900 MHz)
- Low Insertion Loss (2.0 dB typical)
- Sharp rejection peaks close to stop band



CASE STYLE: FV1206

Product Overview

The HFCN-1000+ LTCC High Pass Filter is constructed with 12 layers in order to achieve a miniature size and high repeatability of performance. Wrap-around terminations minimize variations in performance due to parasitics. Covering 1220-4500 MHz, these units offer low insertion loss and good rejection.

Key Features

Feature	Advantages
Small Size (3.20mm x 1.6 mm)	Allows for high layout density of circuit boards, while minimizing affects of parasitics.
Rejection peaks at harmonic frequencies	Provides good rejection of signals at harmonic frequencies, for improved system performance.
Wrap around termination	Provides excellent solderability and easy visual inspection capability.
LTCC construction	Provides a rugged package that is well suited for tough environments including high humidity and high temperature extremes.

Notes

- A. Performance and quality attributes and conditions not expressly stated in this specification document are intended to be excluded and do not form a part of this specification document.
B. Electrical specifications and performance data contained in this specification document are based on Mini-Circuit's applicable established test performance criteria and measurement instructions.
C. The parts covered by this specification document are subject to Mini-Circuits standard limited warranty and terms and conditions (collectively, "Standard Terms"); Purchasers of this part are entitled to the rights and benefits contained therein. For a full statement of the Standard Terms and the exclusive rights and remedies thereunder, please visit Mini-Circuits' website at www.minicircuits.com/MCLStore/terms.jsp

Ceramic High Pass Filter

HFCN-1100+

50Ω 1500 to 3900 MHz



CASE STYLE: FV1206
PRICE: \$1.99 ea. QTY (20)

+RoHS Compliant
The +Suffix identifies RoHS Compliance. See our web site for RoHS Compliance methodologies and qualifications

Available Tape and Reel at no extra cost

Reel Size	Devices/Reel
7"	20, 50, 100, 200, 500, 1000, 3000

Maximum Ratings

Operating Temperature	-55°C to 100°C
Storage Temperature	-55°C to 100°C
RF Power Input*	7W max. at 25°C

* Passband rating, derate linearly to 3W at 100°C ambient.
Permanent damage may occur if any of these limits are exceeded.

Pin Connections

RF IN	1
RF OUT	3
GROUND	2,4

Outline Drawing

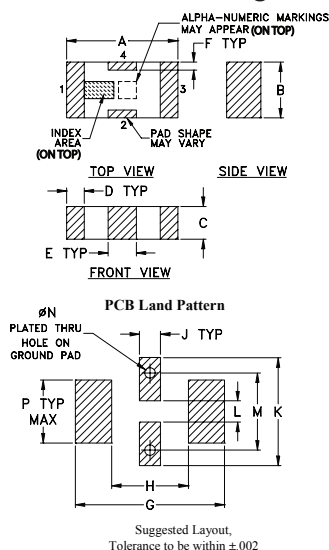

Outline Dimensions (inch)

A	B	C	D	E	F	G	
.126	.063	.037	.020	.032	.009	.169	
3.20	1.60	0.94	0.51	0.81	0.23	4.29	
H	J	K	L	M	N	P	wt
.087	.024	.122	.024	.087	.012	.071	grams
2.21	0.61	3.10	0.61	2.21	0.30	1.80	.020

Demo Board MCL P/N: TB-270 Suggested PCB Layout (PL-137)

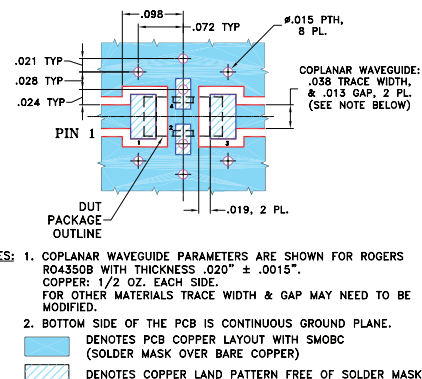

Features

- low cost
- small size
- 7 sections
- temperature stable
- dc block in/out, breakdown voltage, 1kV typ.
- excellent power handling, 7W
- hermetically sealed

Applications

- sub-harmonic rejection
- transmitters/receivers
- lab use

Electrical Specifications^(1,2) at 25°C

Parameter	F#	Frequency (MHz)	Min.	Typ.	Max.	Unit
Stop Band	Rejection Loss	DC-F1	DC-530	40	—	dB
		F1-F2	DC-700	20	—	dB
	Freq. Cut-Off	F3	1100	—	3.0	dB
	VSWR	DC-F2	DC-700	—	20	:1
Pass Band	Insertion Loss	F4-F7	1500-3900	—	—	dB
		F5-F6	1400-3500	—	1.3	dB
	VSWR	F4-F7	1500-3900	—	1.5	:1

(1) In Application where DC voltage is present at either input or output ports, coupling capacitors are required.
(2) Measured on Mini-Circuits Characterization Test Board TB-270.

Typical Frequency Response

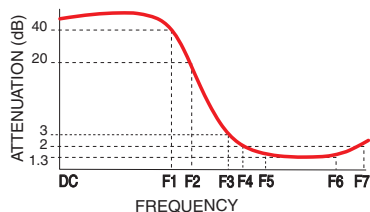

Electrical Schematic

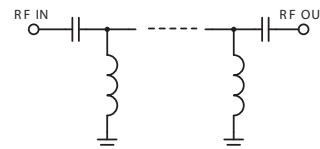

Typical Performance Data at 25°C

Frequency (MHz)	Insertion Loss (dB)	VSWR (:1)
10.0	94.10	>1000
500.0	66.25	96.51
700.0	37.65	48.26
1100.0	2.32	2.11
1380.0	0.70	1.03
1560.0	0.64	1.30
2100.0	0.65	1.60
3420.0	0.44	1.33
3520.0	0.50	1.43
3930.0	0.85	1.91

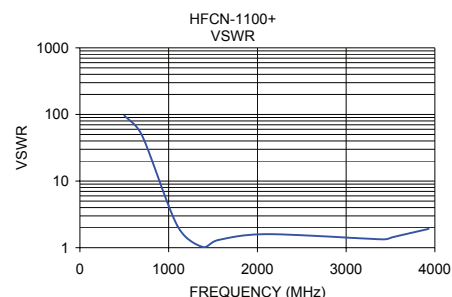
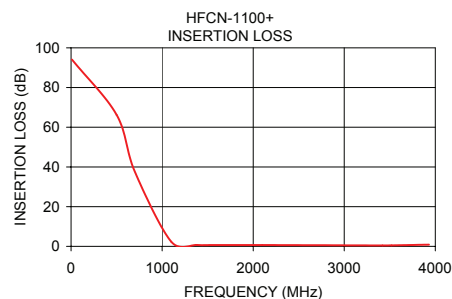

Notes

- Performance and quality attributes and conditions not expressly stated in this specification document are intended to be excluded and do not form a part of this specification document.
- Electrical specifications and performance data contained in this specification document are based on Mini-Circuit's applicable established test performance criteria and measurement instructions.
- The parts covered by this specification document are subject to Mini-Circuits standard limited warranty and terms and conditions (collectively, "Standard Terms"); Purchasers of this part are entitled to the rights and benefits contained therein. For a full statement of the Standard Terms and the exclusive rights and remedies thereunder, please visit Mini-Circuits' website at www.minicircuits.com/MCLStore/terms.jsp

