

Coaxial

# Power Splitter/Combiner

## ZFSC-2-6+

2 Way-0° 50Ω 0.002 to 60 MHz



BNC version shown

CASE STYLE: K18

Connectors	Model	Price	Qty.
BNC	ZFSC-2-6+	\$51.95	(1-9)
SMA	ZFSC-2-6-S+	\$56.95	(1-9)
N-TYPE	ZFSC-2-6-N+	\$56.95	(1-9)
BRACKET (OPTION "B")		\$5.00	(1+)

### Maximum Ratings

Operating Temperature	-55°C to 100°C
Storage Temperature	-55°C to 100°C
Power Input (as a splitter)	1W max.*
Internal Dissipation	0.125W max.

\* At low range frequency band ( $f_L$  to  $10 f_L$ ), linearly derate maximum input power by 13 dB typ.

Permanent damage may occur if any of these limits are exceeded.

### Coaxial Connections

SUM PORT	3
PORT 1	1
PORT 2	2

### Outline Drawing

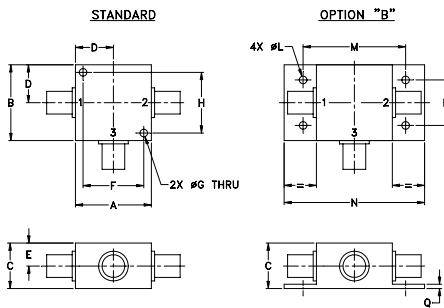

### Outline Dimensions (inch/mm)

A	B	C	D	E	F	G	H
1.25	1.25	.75	.63	.38	1.00	.125	1.000
31.75	31.75	19.05	16.00	9.65	25.40	3.18	25.40
J	K	L	M	N	P	Q	wt
--	--	.125	1.688	2.18	.75	.07	grams
--	--	3.18	42.88	55.37	19.05	1.78	70.0

For option B with N-type connectors, dimension "C" increases to 0.94 inches.

### Features

- low insertion loss, 0.3 dB typ.
- excellent isolation, 30 dB typ.
- excellent amplitude unbalance, 0.1 dB typ.
- excellent phase unbalance, 0.2 deg. typ.
- rugged shielded case

### Applications

- HF
- ham radio
- defense communications

### Electrical Specifications

FREQ. RANGE (MHz)	ISOLATION** (dB)			INSERTION LOSS (dB) ABOVE 3.0 dB			PHASE UNBALANCE (Degrees)			AMPLITUDE UNBALANCE (dB)								
	L	M	U	L	M	U	L	M	U	L	M	U						
$f_L$ - $f_U$	Typ. Min.	Typ. Min.	Typ. Min.	Typ. Max.	Typ. Max.	Typ. Max.	Max.	Max.	Max.	Max.	Max.	Max.						
0.002-60	27	20	30	20	27	20	0.3	0.6	0.3	0.6	0.6	1.0	2	3	4	0.15	0.20	0.30

L = low range [ $f_L$  to  $10 f_L$ ] M = mid range [ $10 f_L$  to  $f_U/2$ ] U = upper range [ $f_U/2$  to  $f_U$ ]

\*\* Isolation specified to 0.006 MHz

### Typical Performance Data

Frequency (MHz)	Total Loss <sup>1</sup> (dB)		Amplitude Unbalance (dB)	Isolation (dB)	Phase Unbalance (deg.)	VSWR S	VSWR 1	VSWR 2
	S-1	S-2						
0.002	3.16	3.17	0.00	30.24	0.10	1.14	1.20	1.20
0.02	3.10	3.10	0.00	37.52	0.05	1.10	1.04	1.04
0.51	3.11	3.11	0.00	37.86	0.06	1.10	1.03	1.03
2.00	3.13	3.13	0.00	37.35	0.06	1.10	1.03	1.03
5.00	3.18	3.18	0.00	35.22	0.06	1.12	1.02	1.02
8.00	3.22	3.22	0.00	33.04	0.05	1.13	1.01	1.01
11.00	3.25	3.25	0.00	31.28	0.05	1.14	1.01	1.01
15.00	3.29	3.29	0.00	29.45	0.05	1.15	1.01	1.01
19.00	3.33	3.33	0.00	28.06	0.04	1.16	1.02	1.02
26.00	3.38	3.38	0.00	26.35	0.04	1.16	1.05	1.05
36.00	3.46	3.46	0.01	24.95	0.06	1.16	1.09	1.09
42.00	3.52	3.50	0.01	24.54	0.08	1.15	1.11	1.12
48.00	3.57	3.55	0.02	24.37	0.12	1.13	1.15	1.15
54.00	3.63	3.61	0.02	24.36	0.16	1.12	1.18	1.19
60.00	3.70	3.66	0.03	24.35	0.22	1.12	1.22	1.23

1. Total Loss = Insertion Loss + 3dB splitter loss.

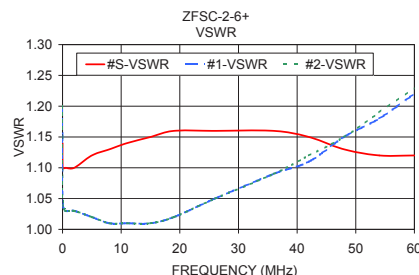
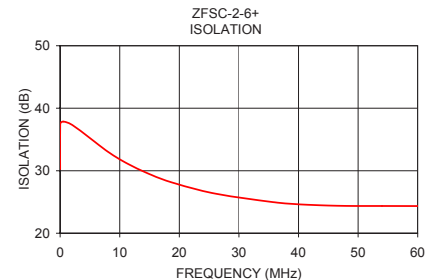
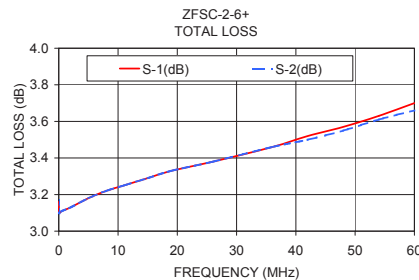

### electrical schematic



P.O. Box 350166, Brooklyn, New York 11235-0003 (718) 934-4500 Fax (718) 332-4661 The Design Engineers Search Engine [www.minicircuits.com](http://www.minicircuits.com) Provides ACTUAL Data Instantly at [www.minicircuits.com](http://www.minicircuits.com)

Notes: 1. Performance and quality attributes and conditions not expressly stated in this specification sheet are intended to be excluded and do not form a part of this specification sheet. 2. Electrical specifications and performance data contained herein are based on Mini-Circuit's applicable established test performance criteria and measurement instructions. 3. The parts covered by this specification sheet are subject to Mini-Circuits standard limited warranty and terms and conditions (collectively, "Standard Terms"); Purchasers of this part are entitled to the rights and benefits contained therein. For a full statement of the Standard Terms and the exclusive rights and remedies thereunder, please visit Mini-Circuits' website at [www.minicircuits.com/MCLStore/terms.jsp](http://www.minicircuits.com/MCLStore/terms.jsp).

For detailed performance specs & shopping online see web site

REV. D  
M131858  
ZFSC-2-6+  
HY/TD/CP/AM  
121012