

Coaxial

Power Splitter/Combiner

ZFSCJ-2-4+

2 Way-180° 50Ω 50 to 1000 MHz



Maximum Ratings

Operating Temperature	-55°C to 100°C
Storage Temperature	-55°C to 100°C
Power Input (as a splitter)	1W max.
Internal Dissipation	0.125W max.
Permanent damage may occur if any of these limits are exceeded.	

Coaxial Connections

SUM PORT	3
PORT 1	1
PORT 2	2

Outline Drawing

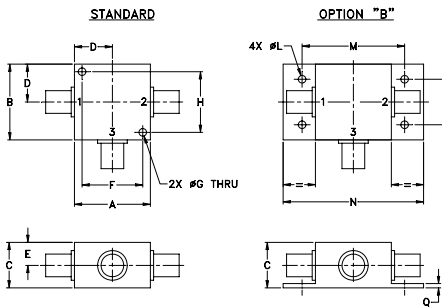

Outline Dimensions (inch/mm)

A	B	C	D	E	F	G	H
1.25	1.25	.75	.63	.38	1.00	.125	1.000
31.75	31.75	19.05	16.00	9.65	25.40	3.18	25.40
J	K	L	M	N	P	Q	wt
--	--	.125	1.688	2.18	.75	.07	grams
--	--	3.18	42.88	55.37	19.05	1.78	70.0

Features

- low insertion loss, 1.4 dB typ.
- high isolation, 28 dB typ.
- rugged shielded case

Applications

- VHF/UHF
- cellular
- signal processing

CASE STYLE: K18

Connectors	Model	Price	Qty.
SMA	ZFSCJ-2-4-S+	\$69.95	(1-9)
BRACKET (OPTION "B")		\$5.00	(1+)

+ RoHS compliant in accordance with EU Directive (2002/95/EC)

The +Suffix has been added in order to identify RoHS Compliance. See our web site for RoHS Compliance methodologies and qualifications.

Electrical Specifications

FREQ. RANGE (MHz)	ISOLATION (dB)				INSERTION LOSS (dB) ABOVE 3.0 dB				PHASE UNBALANCE (Degrees)		AMPLITUDE UNBALANCE (dB)	
	L		U		L		U		L	U	L	U
	Typ.	Min.	Typ.	Min.	Typ.	Max.	Typ.	Max.	Max.	Max.	Max.	Max.
f _L -f _U												
50-1000	30	20	25	18	1.2	1.9	1.6	2.4	6	7	0.6	0.6

L = low range [f_L to 10 f_L] U = upper range [f_U/2 to f_U]

Typical Performance Data

Frequency (MHz)	Total Loss ¹ (dB)		Amplitude Unbalance (dB)	Isolation (dB)	Phase Unbalance (deg.)	VSWR S	VSWR 1	VSWR 2
	S-1	S-2						
50.00	3.69	3.71	0.02	35.02	180.77	1.22	1.20	1.27
140.00	3.88	3.86	0.01	31.04	179.44	1.42	1.32	1.47
230.00	4.15	4.16	0.00	28.34	178.79	1.66	1.47	1.72
365.00	4.46	4.43	0.03	25.57	177.86	1.95	1.66	2.07
500.00	4.64	4.63	0.01	23.95	177.94	2.10	1.77	2.30
560.00	4.78	4.73	0.05	23.39	177.67	2.09	1.78	2.35
620.00	4.78	4.70	0.08	22.87	178.11	2.04	1.78	2.36
680.00	4.79	4.72	0.07	22.42	178.17	1.96	1.75	2.34
720.00	4.64	4.53	0.11	22.11	178.53	1.89	1.72	2.31
750.00	4.55	4.42	0.13	21.69	178.68	1.83	1.70	2.28
780.00	4.85	4.73	0.12	21.93	178.61	1.76	1.66	2.25
840.00	4.48	4.29	0.19	21.17	179.47	1.61	1.59	2.16
920.00	4.47	4.30	0.17	20.99	180.61	1.42	1.49	2.05
960.00	4.60	4.36	0.23	21.04	180.29	1.33	1.44	1.99
1000.00	4.59	4.46	0.13	21.07	178.64	1.25	1.39	1.95

1. Total Loss = Insertion Loss + 3dB splitter loss.

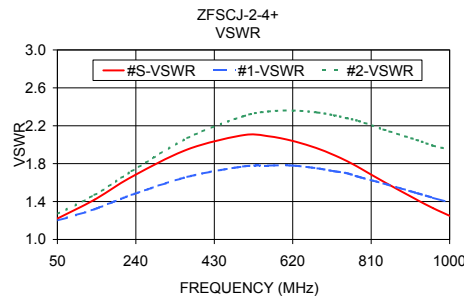
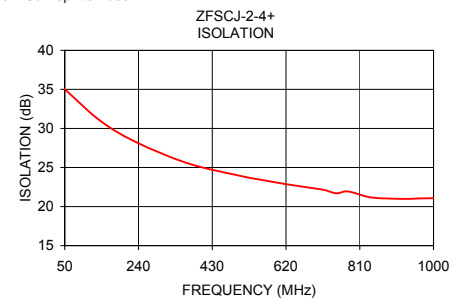
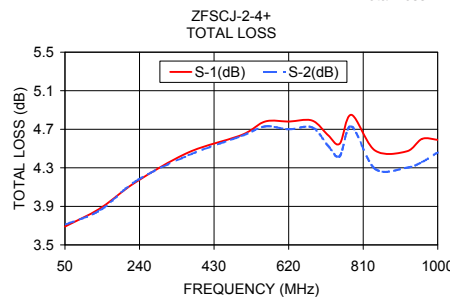

Electrical Schematic

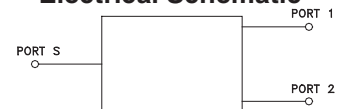

For detailed performance specs & shopping online see web site

P.O. Box 350166, Brooklyn, New York 11235-0003 (718) 934-4500 Fax (718) 332-4661 The Design Engineers Search Engine Provides ACTUAL Data Instantly at minicircuits.com

Notes: 1. Performance and quality attributes and conditions not expressly stated in this specification sheet are intended to be excluded and do not form a part of this specification sheet. 2. Electrical specifications and performance data contained herein are based on Mini-Circuit's applicable established test performance criteria and measurement instructions. 3. The parts covered by this specification sheet are subject to Mini-Circuits standard limited warranty and terms and conditions (collectively, "Standard Terms"); Purchasers of this part are entitled to the rights and benefits contained therein. For a full statement of the Standard Terms and the exclusive rights and remedies thereunder, please visit Mini-Circuits' website at www.minicircuits.com/MCLStore/terms.jsp.

REV. C
M127604
ZFSCJ-2-4+
HY/TD/CP/AM
120306