

Ceramic, Hermetic SPDT RF Switch

50Ω 500-6000 MHz

Absorptive RF Switch with internal driver.
Single Supply Voltage, +3V to +5V

Product Features

- Wide bandwidth, 500 to 6000 MHz
- High Isolation, 65 dB typ. at 1 GHz
- Low insertion loss, 1.0 dB typ.
- Internal CMOS driver
- Fast switching, Rise/fall time, 30 ns typ.
- Built rugged for tough environments
- Hermetically sealed
- Wide operating temperature, -55°C to 125°C

Typical Applications

- Automated switching networks
- Cellular
- PCN
- ISM, WCDMA, WiMAX
- Military

General Description

The CSWA2-63DR+ is a 50Ω high isolation, absorptive SPDT RF switch designed for wireless applications, covering a broad frequency range from 500 to 6000 MHz with low insertion loss. In non absorptive mode, the switch is usable down to 0.3 MHz. It may also be used in 75Ω systems over 0.3-3000 MHz. The CSWA2-63DR+ operates on a single supply voltage in the range of +3V to +5V. This unit includes an internal CMOS driver. The switch consumes very low supply current, 18 μA typ. The CSWA2-63DR+ switch comes in a low profile hermetic very small size package, 4mm x 4mm x 1.2mm. Expected MTBF is 373 years at 85°C case temperature.



CSWA2-63DR+

CASE STYLE: DG1293
PRICE: \$6.70 ea. QTY. (20)

MIL screening available
Please consult Applications Dept.

+RoHS Compliant

The +Suffix identifies RoHS Compliance. See our web site for RoHS Compliance methodologies and qualifications

Schematic and Application Circuit

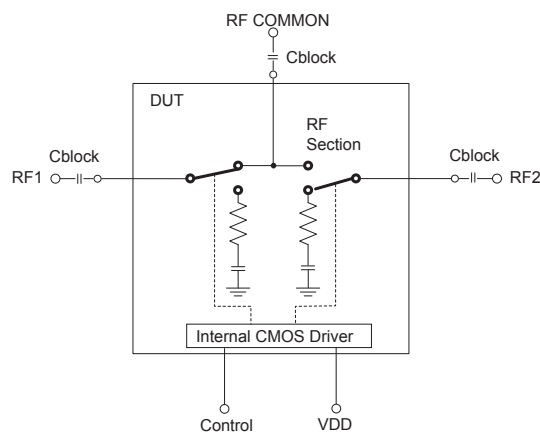

Cblock should be free of resonance over frequency of operation.

Frequency (MHz)	Cblock (Suggested value)
0.3-500	0.1μF
500-6000	47pF

Notes

- Performance and quality attributes and conditions not expressly stated in this specification document are intended to be excluded and do not form a part of this specification document.
- Electrical specifications and performance data contained in this specification document are based on Mini-Circuit's applicable established test performance criteria and measurement instructions.
- The parts covered by this specification document are subject to Mini-Circuits standard limited warranty and terms and conditions (collectively, "Standard Terms"); Purchasers of this part are entitled to the rights and benefits contained therein. For a full statement of the Standard Terms and the exclusive rights and remedies thereunder, please visit Mini-Circuits' website at www.minicircuits.com/MCLStore/terms.jsp



RF Electrical Specifications⁽¹⁾, 500 - 6000 MHz, T_{AMB}=25°C, V_{DD}= +3V to +5V

Parameter		Min.	Typ.	Max.	Units
Frequency Range		500		6000	MHz
Insertion Loss	0.3 to 500 MHz		1.0		dB
	500 to 2000 MHz		1.0	1.3	
	2000 to 3000 MHz		1.1	1.4	
	3000 to 4000 MHz		1.2	1.5	
	4000 to 6000 MHz		1.5	1.8	
Isolation between Common port and RF1/RF2 Ports	0.3 to 500 MHz		60		dB
	500 to 2000 MHz	54	70		
	2000 to 3000 MHz	50	60		
	3000 to 4000 MHz	50	54		
	4000 to 6000 MHz	40	44		
Isolation between RF1 and RF2 ports	0.3 to 500 MHz		76		dB
	500 to 2000 MHz	52	64		
	2000 to 3000 MHz	50	54		
	3000 to 4000 MHz	44	50		
	4000 to 6000 MHz	36	44		
Return Loss (ON STATE)	0.3 to 500 MHz		20		dB
	100 to 2000 MHz		20		
	2000 to 3000 MHz		15		
	3000 to 4000 MHz		15		
Return Loss @ RF1/RF2 ports (OFF STATE)	500 to 2000 MHz		13		dB
	2000 to 3000 MHz		13		
	3000 to 4000 MHz		14		
	4000 to 6000 MHz		14		
Input IP3	V _{DD} =3V, 500 to 2000 MHz		47		dBm
	2000 to 6000 MHz		40		
	V _{DD} =5V, 500 to 2000 MHz		50		
	2000 to 6000 MHz		45		
Input 1dB Compression ⁽²⁾	V _{DD} =3V, 500 to 2000 MHz		24		dBm
	2000 to 6000 MHz		24		
	V _{DD} =5V, 500 to 2000 MHz		30		
	2000 to 6000 MHz		27		

DC Electrical Specifications

Parameter	Min.	Typ.	Max.	Units
VDD, Supply Voltage	3		5	V
Supply Current (V _{DD} = 5V) ⁽³⁾		18		μA
Control Voltage Low	0		0.5	V
Control Voltage High ⁽⁴⁾	2.7		V _{DD}	V
Control Current		5		μA

Notes:

- Insertion loss values are deembedded from test board loss. Tested using Agilent's N5230A network analyzer with internal DC blocks, except for IP3 and compression.
- Note absolute maximum rating for input and dissipated power. At 5V, over 2000-6000 MHz, 0.2 dB compression.
- Increases with switching repetition rate. See graph.
- CMOS interface latch-up condition may occur when logic high signal is applied prior to power supply.

Switching Specifications at V_{DD}=5V

Parameter	Min.	Typ.	Max.	Units
Rise/Fall Time (10 to 90% or 90 to 10% RF)		23		nSec
Switching Time (50% CTRL to 90/10% RF)		35		nSec
Video Feedthrough (Control 0-5V, Frequency 1 MHz)		25		mV _{p-p}

Notes

- Performance and quality attributes and conditions not expressly stated in this specification document are intended to be excluded and do not form a part of this specification document.
- Electrical specifications and performance data contained in this specification document are based on Mini-Circuit's applicable established test performance criteria and measurement instructions.
- The parts covered by this specification document are subject to Mini-Circuits standard limited warranty and terms and conditions (collectively, "Standard Terms"); Purchasers of this part are entitled to the rights and benefits contained therein. For a full statement of the Standard Terms and the exclusive rights and remedies thereunder, please visit Mini-Circuits' website at www.minicircuits.com/MCLStore/terms.jsp



Absolute Maximum Ratings

Parameter	Ratings
Operating Temperature	-55°C to 125°C
Storage Temperature	-65°C to 150°C
V _{DD} , Supply Voltage	2.7 to 5.5V
Voltage Control	-0.2V Min. V _{DD} Max.
RF input power	1Watt
Dissipated Power at 25°C	370mW
ESD, HBM	Class 1A (250 to <500V) per JESD22-A114
ESD, MM	Class A (passes 50V) per JESD22-A115
ESD, CDM	Class III (500 to <1000V) per JESD22-C101

Truth Table (State of control voltage selects the desired switch state)

State of Control Voltage	Switch State - RF Common to	
	RF1	RF2
Low	ON	OFF
High	OFF	ON

ON- low insertion loss state
OFF- Isolation State

Pad Connections

Function	Pad Number	Description
RF COM	15	RF Common/ SUM Port
RF1	4	RF Out #1/In Port #1
RF2	9	RF Out #1/In Port #2
Control	13	CMOS Control IN
VDD	12	Supply Voltage
GND	1,2,3,5,6,7,8,10,11,14,16, paddle	RF Ground

Pad Configuration (Top View)

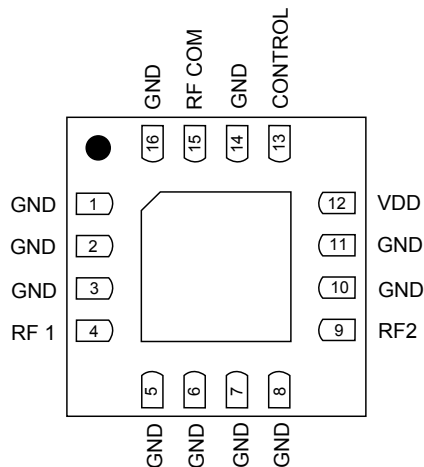

Notes

- A. Performance and quality attributes and conditions not expressly stated in this specification document are intended to be excluded and do not form a part of this specification document.
- B. Electrical specifications and performance data contained in this specification document are based on Mini-Circuit's applicable established test performance criteria and measurement instructions.
- C. The parts covered by this specification document are subject to Mini-Circuits standard limited warranty and terms and conditions (collectively, "Standard Terms"); Purchasers of this part are entitled to the rights and benefits contained therein. For a full statement of the Standard Terms and the exclusive rights and remedies thereunder, please visit Mini-Circuits' website at www.minicircuits.com/MCLStore/terms.jsp



Product Marking

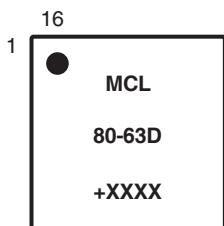

Additional Detailed Technical Information

Additional information is available on our web site. To access this information enter the model number on our web site home page.

Performance data, graphs

Case Style: DG1293

Ceramic, finish: gold over nickel

Tape & Reel: F70

Standard quantities available on reel: 7" reels with 20, 50, 100, 200, 500, 1K devices.
13" reels with 2K devices.

Suggested Layout for PCB Design: PL-279

Evaluation Board: TB-461+

Environmental Ratings: ENV40

Notes

- A. Performance and quality attributes and conditions not expressly stated in this specification document are intended to be excluded and do not form a part of this specification document.
- B. Electrical specifications and performance data contained in this specification document are based on Mini-Circuit's applicable established test performance criteria and measurement instructions.
- C. The parts covered by this specification document are subject to Mini-Circuits standard limited warranty and terms and conditions (collectively, "Standard Terms"); Purchasers of this part are entitled to the rights and benefits contained therein. For a full statement of the Standard Terms and the exclusive rights and remedies thereunder, please visit Mini-Circuits' website at www.minicircuits.com/MCLStore/terms.jsp

