

MECHANICAL DATA

Dimensions in mm (inches)

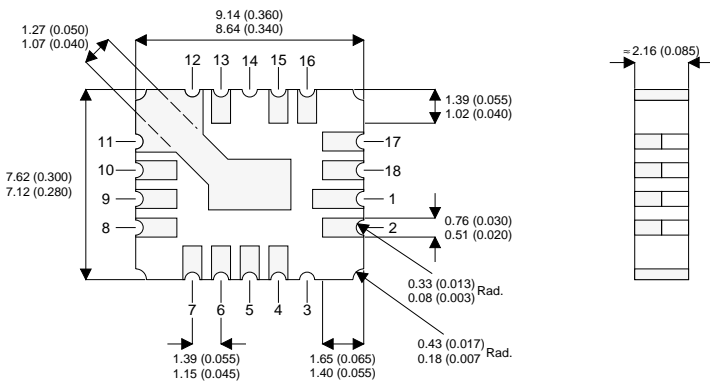

LCC4

MOSFET	PADS
GATE	4,5
DRAIN	1,2,15,16,17,18
SOURCE	6,7,8,9,10,11,12,13

**N-CHANNEL
POWER MOSFET**

V_{DSS} **60V**
 $I_{D(cont)}$ **6.7A**
 $R_{DS(on)}$ **0.15Ω**

FEATURES

- SURFACE MOUNT
- SMALL FOOTPRINT
- HERMETICALLY SEALED
- DYNAMIC dv/dt RATING
- AVALANCHE ENERGY RATING
- SIMPLE DRIVE REQUIREMENTS
- LIGHTWEIGHT

ABSOLUTE MAXIMUM RATINGS ($T_{case} = 25^{\circ}C$ unless otherwise stated)

V_{GS}	Gate – Source Voltage	$\pm 20V$
I_D	Continuous Drain Current ($V_{GS} = 10V, T_{case} = 25^{\circ}C$)	6.7A
I_D	Continuous Drain Current ($V_{GS} = 10V, T_{case} = 100^{\circ}C$)	4.2A
I_{DM}	Pulsed Drain Current ¹	27A
P_D	Power Dissipation @ $T_{case} = 25^{\circ}C$	14W
	Linear Derating Factor	0.11W/ $^{\circ}C$
E_{AS}	Single Pulse Avalanche Energy ²	110mJ
dv/dt	Peak Diode Recovery ³	5.5V/ns
T_J, T_{stg}	Operating and Storage Temperature Range	-55 to +150 $^{\circ}C$
	Surface Temperature (for 5 sec).	300 $^{\circ}C$

Notes

- 1) Pulse Test: Pulse Width $\leq 300\mu s, \delta \leq 2\%$
- 2) @ $V_{DD} = 50V, L \geq 570\mu H, R_G = 25\Omega, Peak I_L = 14A, Starting T_J = 25^{\circ}C$
- 3) @ $I_{SD} \leq 14A, di/dt \leq 140A/\mu s, V_{DD} \leq BV_{DSS}, T_J \leq 150^{\circ}C, Suggested R_G = 7.5\Omega$

ELECTRICAL CHARACTERISTICS ($T_{\text{case}} = 25^{\circ}\text{C}$ unless otherwise stated)

Parameter	Test Conditions	Min.	Typ.	Max.	Unit
STATIC ELECTRICAL RATINGS					
BV_{DSS} Drain – Source Breakdown Voltage	$V_{\text{GS}} = 0$ $I_{\text{D}} = 1\text{mA}$	60			V
$\frac{\Delta BV_{\text{DSS}}}{\Delta T_{\text{J}}}$ Temperature Coefficient of Breakdown Voltage	Reference to 25°C $I_{\text{D}} = 1\text{mA}$		0.068		$\text{V}/^{\circ}\text{C}$
$R_{\text{DS(on)}}$ Static Drain – Source On–State Resistance ¹	$V_{\text{GS}} = 10\text{V}$ $I_{\text{D}} = 4.2\text{A}$ $V_{\text{GS}} = 10\text{V}$ $I_{\text{D}} = 6.7\text{A}$			0.15 0.17	Ω
$V_{\text{GS(th)}}$ Gate Threshold Voltage	$V_{\text{DS}} = V_{\text{GS}}$ $I_{\text{D}} = 250\mu\text{A}$	2		4	V
g_{fs} Forward Transconductance ¹	$V_{\text{DS}} \geq 15\text{V}$ $I_{\text{DS}} = 4.2\text{A}$	4.3			S (\bar{v})
I_{DSS} Zero Gate Voltage Drain Current	$V_{\text{GS}} = 0$ $V_{\text{DS}} = 0.8BV_{\text{DSS}}$ $T_{\text{J}} = 125^{\circ}\text{C}$			25 250	μA
I_{GSS} Forward Gate – Source Leakage	$V_{\text{GS}} = 20\text{V}$			100	nA
I_{GSS} Reverse Gate – Source Leakage	$V_{\text{GS}} = -20\text{V}$			-100	nA
DYNAMIC CHARACTERISTICS					
C_{iss} Input Capacitance	$V_{\text{GS}} = 0$		640		pF
C_{oss} Output Capacitance	$V_{\text{DS}} = 25\text{V}$		340		
C_{riss} Reverse Transfer Capacitance	$f = 1\text{MHz}$		69		
Q_{g} Total Gate Charge	$V_{\text{GS}} = 10\text{V}$	9.0		26	nC
Q_{gs} Gate – Source Charge	$I_{\text{D}} = 6.7\text{A}$	2.0		5.0	
Q_{gd} Gate – Drain (“Miller”) Charge	$V_{\text{DS}} = 0.5BV_{\text{DSS}}$	6.0		13	
$t_{\text{d(on)}}$ Turn–On Delay Time	$V_{\text{DD}} = 30\text{V}$			14	ns
t_{r} Rise Time	$I_{\text{D}} = 6.7\text{A}$			70	
$t_{\text{d(off)}}$ Turn–Off Delay Time	$R_{\text{G}} = 7.5\Omega$			37	
t_{f} Fall Time				45	
SOURCE – DRAIN DIODE CHARACTERISTICS					
I_{S} Continuous Source Current				6.7	A
I_{SM} Pulse Source Current ²				27	
V_{SD} Diode Forward Voltage ¹	$I_{\text{S}} = 6.7\text{A}$ $T_{\text{J}} = 25^{\circ}\text{C}$ $V_{\text{GS}} = 0$			2.3	V
t_{rr} Reverse Recovery Time	$I_{\text{F}} = 6.7\text{A}$ $T_{\text{J}} = 25^{\circ}\text{C}$			200	ns
Q_{rr} Reverse Recovery Charge ¹	$d_{\text{i}} / d_{\text{t}} \leq 100\text{A}/\mu\text{s}$ $V_{\text{DD}} \leq 50\text{V}$			1.9	μC
t_{on} Forward Turn–On Time			Negligible		
PACKAGE CHARACTERISTICS					
L_{D} Internal Drain Inductance (measured from 6mm down drain lead to centre of die)			1.8		nH
L_{S} Internal Source Inductance (from 6mm down source lead to source bond pad)			4.3		
THERMAL CHARACTERISTICS					
$R_{\theta\text{JC}}$ Thermal Resistance Junction – Case				9.1	$^{\circ}\text{C}/\text{W}$
$R_{\theta\text{JPC}}$ Thermal Resistance Junction – PC Board				26	

Notes

- 1) Pulse Test: Pulse Width $\leq 300\text{ms}$, $\delta \leq 2\%$
- 2) Repetitive Rating – Pulse width limited by maximum junction temperature.