

MECHANICAL DATA

Dimensions in mm (inches)

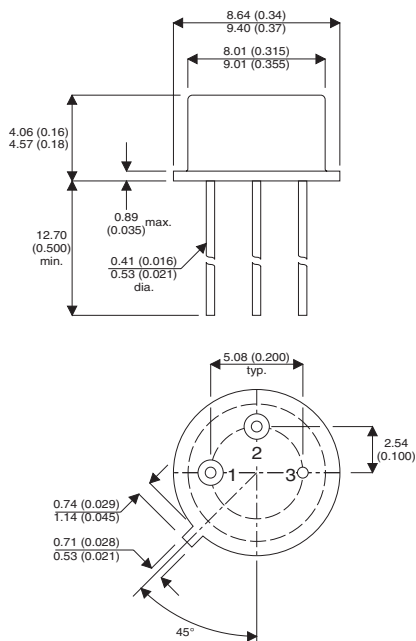

**N-CHANNEL ENHANCEMENT
MODE TRANSISTOR**

FEATURES

- $V_{(BR)DSS} = 200V$
- $I_D = 5.5A$
- $R_{DS(ON)} = 0.40\Omega$

TO-39 PACKAGE (TO-205AF)

Underside View

PIN 1 – Source PIN 2 – Gate PIN 3 – Drain

ABSOLUTE MAXIMUM RATINGS ($T_{case} = 25^\circ C$ unless otherwise stated)

V_{DS}	Drain–Source Voltage	200V
V_{GS}	Gate–Source Voltage	$\pm 20V$
I_D	Drain Current Continuous $T_{Case} = 25^\circ C$ $T_{Case} = 100^\circ C$	5.5A 3.5A
I_{DM}	Drain Current Pulsed	22A
P_D	Total Device Dissipation @ $T_{Case} = 25^\circ C$ $T_{Case} = 100^\circ C$	25W 10W
T_J, T_{STG}	Operating and Storage Junction Temperature Range	-55 to $+150^\circ C$
THERMAL CHARACTERISTICS		
$R_{\theta JC}$	Thermal Resistance Junction to Case	$5.0^\circ C/W$
$R_{\theta JA}$	Thermal Resistance Junction to Ambient	$175^\circ C/W$
T_L	Maximum Lead Temperature 1.6mm from Case for 10 secs.	$300^\circ C$

Semelab Plc reserves the right to change test conditions, parameter limits and package dimensions without notice. Information furnished by Semelab is believed to be both accurate and reliable at the time of going to press. However Semelab assumes no responsibility for any errors or omissions discovered in its use. Semelab encourages customers to verify that datasheets are current before placing orders.

ELECTRICAL CHARACTERISTICS ($T_j = 25^\circ\text{C}$ unless otherwise stated)

Parameter	Test Conditions	Min.	Typ.	Max.	Unit				
$V_{(BR)DSS}$	Drain–Source Breakdown Voltage	$V_{GS} = 0$	$I_D = 1\text{mA}$	200		V			
$V_{GS(th)}$	Gate Threshold Voltage	$V_{DS}=V_{GS}$	$I_D = 250\mu\text{A}$	2.0	4.0				
I_{GSS}	Gate–Body Leakage	$V_{DS} = 0$	$V_{GS} = \pm 20\text{V}$		± 100	nA			
I_{DSS}	Zero Gate Voltage Drain Current	$V_{DS} = 0.8 \times V_{(BR)DSS}$			25	μA			
		$V_{GS} = 0$	$T_j = 125^\circ\text{C}$		250				
$r_{DS(on)}$	Drain–Source On–Resistance ¹	$V_{GS} = 10\text{V}$	$I_D = 3.5\text{A}$		0.25	0.4	Ω		
g_{fs}	Forward Transconductance ¹	$V_{DS} = 15\text{V}$	$I_D = 3.5\text{A}$	2.5	3.0		$\text{s}(\bar{\nu})$		
C_{iss}	Input Capacitance	$V_{DS} = 25\text{V}$	$V_{GS} = 0$		600		pF		
C_{oss}	Output capacitance				250				
C_{rss}	Reverse Transfer Capacitance			$f = 1.0\text{MHz}$	80				
t_{don}	Turn–On Delay Time	$V_{DD} = 77\text{V}$	$R_L = 22\Omega$		8	30	ns		
t_r	RiseTime			$I_D = 3.5\text{A}$	$V_{GEN} = 10\text{V}$			42	50
$t_{d(of)}$	Turn off Delay Time			$R_G = 7.5\text{ ohms}$				12	50
t_f	FallTime								30
SOURCE DRAIN DIODE RATING CHARACTERISTICS									
V_{SD}	Diode Forward Voltage ¹	$I_F = 5.5\text{A}$	$V_{GS} = 0$			1.4	V		
I_S	Continues Current					5.5	A		
I_{SM}	Pulsed Current ²					22			
t_{rr}	Reverse Recovery Time	$I_F = 5.5\text{A}$	$V_{DD} = 50\text{V}$		150	500	ns		
Q_{rr}	Reverse Recovered Charge	$dI_F/DT = 100\text{A}/\mu\text{S}$				6	μC		

- 1) Pulse test : Pulse Width < 300 μs ,Duty Cycle < 2%
- 2) Pulse width limited by maximum junction temperature