

# SILICON PNP TRANSISTOR

## BFX29

- Hermetic TO-39 Metal package.
- Ideally suited for Switching and General Purpose Applications
- Screening Options Available

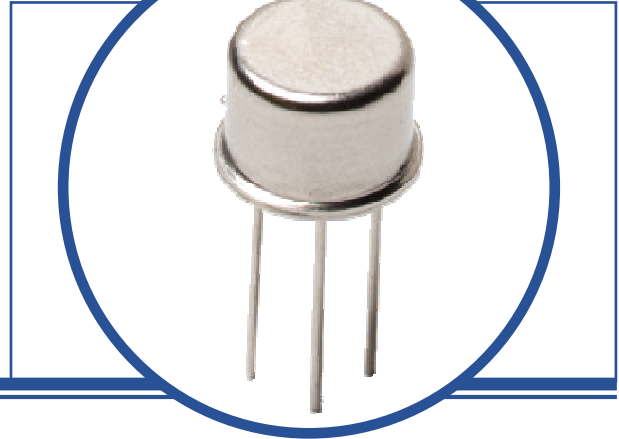

### ABSOLUTE MAXIMUM RATINGS ( $T_C = 25^\circ\text{C}$ unless otherwise stated)

$V_{CBO}$	Collector – Base Voltage	60V
$V_{CEO}$	Collector – Emitter Voltage	60V
$V_{EBO}$	Emitter – Base Voltage	5V
$I_C$	Continuous Collector Current	600mA
$I_{CM}$	Peak Collector Current	600mA
$P_D$	Total Power Dissipation at $T_A = 25^\circ\text{C}$ Derate Above $25^\circ\text{C}$	600mW 34mW/ $^\circ\text{C}$
$T_J$	Junction Temperature Range	-65 to +200 $^\circ\text{C}$
$T_{stg}$	Storage Temperature Range	-65 to +200 $^\circ\text{C}$

### THERMAL PROPERTIES

Symbols	Parameters	Max.	Units
$R_{\theta JA}$	Thermal Resistance, Junction To Ambient	292	$^\circ\text{C/W}$

Semelab Limited reserves the right to change test conditions, parameter limits and package dimensions without notice. Information furnished by Semelab is believed to be both accurate and reliable at the time of going to press. However Semelab assumes no responsibility for any errors or omissions discovered in its use. Semelab encourages customers to verify that datasheets are current before placing orders.



# SILICON PNP TRANSISTOR

## BFX29

### ELECTRICAL CHARACTERISTICS ( $T_J = 25^\circ\text{C}$ unless otherwise stated)

Symbols	Parameters	Test Conditions	Min.	Typ	Max.	Units
$I_{EBO}$	Emitter Cut-Off Current	$V_{EB} = 5V$ $I_C = 0$		220	500	nA
		$V_{EB} = 3V$ $I_C = 0$		4	100	
$I_{CBO}$	Collector Cut-Off Current	$V_{CB} = 60V$ $I_E = 0$		1.0	500	
		$V_{CB} = 50V$ $I_E = 0$		0.5	50	
		$T_J = 100^\circ\text{C}$		0.03	2	$\mu\text{A}$
$V_{CE(sat)}^{(1)}$	Collector-Emitter Saturation Voltage	$I_C = 150\text{mA}$ $I_B = 15\text{mA}$		0.15	0.40	V
$V_{BE(sat)}^{(1)}$	Base-Emitter Saturation Voltage	$I_C = 30\text{mA}$ $I_B = 1.0\text{mA}$		0.7	0.90	
		$I_C = 150\text{mA}$ $I_B = 15\text{mA}$		0.85	1.30	
$h_{FE}^{(1)}$	Forward-current transfer ratio	$I_C = 0.1\text{mA}$ $V_{CE} = 10V$	20	218		-
		$I_C = 1.0\text{mA}$ $V_{CE} = 10V$	40	216		
		$I_C = 10\text{mA}$ $V_{CE} = 10V$	50	210		
		$I_C = 50\text{mA}$ $V_{CE} = 10V$	50	195		
		$I_C = 150\text{mA}$ $V_{CE} = 10V$	40	175		

### DYNAMIC CHARACTERISTICS

$f_T$	Transition Frequency	$I_C = 50\text{mA}$ $V_{CE} = 10V$ $f = 100\text{MHz}$ $T_A = 25^\circ\text{C}$	100	280		MHz
$C_{obo}$	Output Capacitance	$V_{CB} = 10V$ $I_E = 0$ $f = 1.0\text{MHz}$		12	15	pF
$C_{ibo}$	Input Capacitance	$V_{EB} = 2V$ $I_C = 0$ $f = 1.0\text{MHz}$		37	40	

#### Notes

(1) Pulse Width  $\leq 380\mu\text{s}$ ,  $\delta \leq 2\%$

# SILICON PNP TRANSISTOR BFX29

## MECHANICAL DATA

Dimensions in mm (inches)

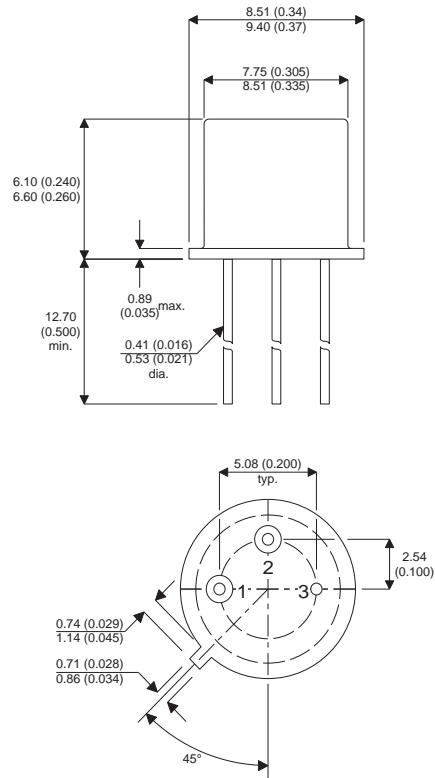

### TO-39 (TO-205AD) METAL PACKAGE Underside View

Pin 1 - Emitter

Pin 2 - Base

Pin 3 - Collector