

LUXEON K

High efficacy plug and play array solution
with precise flux, V_f and color

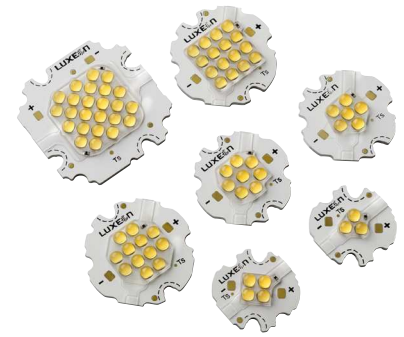

Introduction

The LUXEON® K arrays deliver high flux at high efficacy in a small, easy to use package. The high lumen density enables high light output in thermally and space constrained systems like retrofit lamps and high efficiency in systems like downlights aiming for high energy efficiency. The small size bolt down package enables simple assembly in space constrained systems. With *Freedom from Binning*, every LUXEON K white product falls within a single 3-step MacAdam ellipse positioned around the center point of the ANSI nominal CCT bins to deliver tight Correlated Color Temperature control to ensure consistency in system color point. In addition, these parts deliver the lumen maintenance and reliability that all LUXEON LEDs are renowned for. This document contains the performance data needed to design and engineer LUXEON K based applications.

Features

- Fully characterized 'light source' with *Freedom from Binning*
- High flux density and lumen offerings of 400-5000+
- CCTs from 2700K to 6500K and Royal Blue
- High flux density for compact lamp solutions
- 3 SDCM color consistency
- Industry's smallest V_f (+/- 5%) & flux range (+/- 10%)
- LM-80 test reports available
- Comprehensive and enabling ecosystem

Benefits

- Drop-in solution for cost competitive applications
- Exceptional lamp to lamp consistency (<3MA)
- Single color, flux, or V_f bin
- Easy mechanical assembly
- Reduction in total cost – no binning or PnP
- Faster time to market – ease of design/assembly

Key Applications

- Retrofit Lamps
- Downlight

Table of Contents

General Information	2
Product Nomenclature	2
Average Lumen Maintenance Characteristics	2
Environmental Compliance	2
Product Selection.	3
Optical Characteristics	5
Electrical Characteristics	6
Absolute Maximum Ratings	7
Electrical Lead Soldering Characteristics	7
Mechanical Dimensions	8
Relative Spectral Distribution vs.Wavelength Characteristics	15
Light Output Characteristics over Temperature.	16
Typical Forward Current Characteristics	17
Typical Radiation Patterns	23
Packaging on Trays	23
LUXEON K White ANSI Color Bin Definition.	26

General Information

Product Nomenclature

LUXEON K products are specified and binned “hot” ($T_j = 85^\circ\text{C}$) under conditions comparable to those found in “real-world” lighting products.

The part number designation is explained as follows:

L X K A - P B C D - E F G H J

Where:

- A — designates minimum CRI performance (value 8 = 80 minimum, value 9 = 90 minimum, value 0 for Royal Blue)
- B — designates color (value W = White, value R = Royal Blue)
- C, D — designates nominal ANSI CCT (value 27 = 2700K, 30 = 3000K, 35 = 3500K, 40 = 4000K, 50 = 5000K, and 04 = Royal Blue 447.5nm - 452.5nm peak wavelength)
- E, F — custom spec designation or multi-junction designation (F - Number of strings, H number of emitters, for example 0206, 2 strings of 3 = total emitters of 6)
- G, H — emitter count
- J — denotes a flux upgrade (e.g, A, B, C, etc)

Therefore, 3000K products specified at 350 mA 85°C follow the part numbering scheme:

- L X K 8 - P W 3 0 - 0 0 0 4 for LUXEON K White 3000K 4-up
- L X K 8 - P W 3 0 - 0 0 0 8 for LUXEON K White 3000K 8-up
- L X K 0 - P R 0 4 - 0 0 0 8 for LUXEON K Royal Blue 8-up

Average Lumen Maintenance Characteristics

Lumen maintenance for solid-state lighting devices (LEDs) is typically defined in terms of the percentage of initial light output remaining after a specified period of time. Philips Lumileds projects that LUXEON K products will deliver, on average, 70% lumen maintenance (L70) at 50,000 hours of operation at a forward current of up to 700 mA. This projection is based on constant current operation with junction temperature maintained at or below 125°C . This performance is based on independent test data, Philips Lumileds historical data from tests run on similar material systems, and internal LUXEON reliability testing. Observation of design limits included in this data sheet is required in order to achieve this projected lumen maintenance.

Environmental Compliance

Philips Lumileds is committed to providing environmentally friendly products to the solid-state lighting market. LUXEON K is compliant to the European Union directives on the restriction of hazardous substances in electronic equipment, namely the RoHS directive. Philips Lumileds will not intentionally add the following restricted materials to the LUXEON K: lead, mercury, cadmium, hexavalent chromium, polybrominated biphenyls (PBB) or polybrominated diphenyl ethers (PBDE).

Product Selection

Product Selection Guide for LUXEON K White, Junction Temperature = 85°C

Table 1.

Nominal CCT	Emitter Count	Part Number	Test Current (mA)	Minimum CRI	Typical CRI	Minimum Flux (lm)	Typical Flux (lm)	Maximum Flux (lm)
2700	*3	LXK8-PW27-0403	87.5	80	83	270	285	320
2700	4	LXK8-PW27-0004A	350	80	83	360	401	430
2700	*4	LXK8-PW27-0404	87.5	80	83	340	370	410
2700	*6	LXK8-PW27-0206	175	80	83	530	555	640
2700	8	LXK8-PW27-0008A	350	80	83	730	765	870
2700	12	LXK8-PW27-0012A	350	80	83	1100	1148	1320
2700	16	LXK8-PW27-0016A	350	80	83	1480	1530	1770
2700	24	LXK8-PW27-0024A	350	80	83	2230	2378	2670
3000	*3	LXK8-PW30-0403	87.5	80	83	270	285	320
3000	4	LXK8-PW30-0004A	350	80	83	380	426	450
3000	*4	LXK8-PW30-0404	87.5	80	83	355	385	420
3000	*6	LXK8-PW30-0206	175	80	83	540	575	650
3000	8	LXK8-PW30-0008A	350	80	83	760	783	910
3000	12	LXK8-PW30-0012A	350	80	83	1140	1200	1360
3000	16	LXK8-PW30-0016A	350	80	83	1520	1568	1820
3000	24	LXK8-PW30-0024A	350	80	83	2280	2445	2730
3500	4	LXK8-PW35-0004	350	80	83	400	423	480
3500	8	LXK8-PW35-0008	350	80	83	820	845	980
3500	12	LXK8-PW35-0012	350	80	83	1200	1265	1440
3500	16	LXK8-PW35-0016	350	80	83	1590	1703	1900
3500	24	LXK8-PW35-0024	350	80	83	2420	2570	2900
4000	*3	LXK8-PW40-0403	87.5	80	83	310	330	370
4000	4	LXK8-PW40-0004A	350	80	83	420	445	500
4000	*4	LXK8-PW40-0404	87.5	80	83	410	430	490
4000	*6	LXK8-PW40-0206	175	80	83	625	660	750
4000	8	LXK8-PW40-0008A	350	80	83	820	886	980
4000	12	LXK8-PW40-0012A	350	80	83	1250	1329	1500
4000	16	LXK8-PW40-0016A	350	80	83	1680	1860	2010
4000	24	LXK8-PW40-0024A	350	80	83	2530	2660	3030
5000K	4	LXK8-PW50-0004	350	80	83	440	463	530
5000K	8	LXK8-PW50-0008	350	80	83	890	933	1070
5000K	8	LXK8-PW50-0008	350	80	83	1310	1389	1570
5000K	16	LXK8-PW50-0016	350	80	83	1760	1850	2110
5000K	24	LXK8-PW50-0024	350	80	83	2650	2767	3180
2700	4	LXK9-PW27-0004	350	90	93	300	320	360
2700	8	LXK9-PW27-0008	350	90	93	610	640	730
2700	12	LXK9-PW27-0012	350	90	93	940	960	1120
2700	16	LXK9-PW27-0016	350	90	93	1265	1280	1510
2700	24	LXK9-PW27-0024	350	90	93	1880	1925	2250

Table 1 continued on page 4.

Table I Continued.

Nominal CCT	Emitter Count	Part Number	Test Current (mA)	Minimum CRI	Typical CRI	Minimum Flux (lm)	Typical Flux (lm)	Maximum Flux (lm)
3000	4	LXK9-PW30-0004	350	90	93	320	350	380
3000	8	LXK9-PW30-0008	350	90	93	660	695	790
3000	12	LXK9-PW30-0012	350	90	93	1010	1050	1210
3000	16	LXK9-PW30-0016	350	90	93	1350	1400	1620
3000	24	LXK9-PW30-0024	350	90	93	2045	2110	2450
2700**	4	LXK8-PW27-0004	350	80	83	310	345	370
2700**	8	LXK8-PW27-0008	350	80	83	680	690	810
2700**	12	LXK8-PW27-0012	350	80	83	990	1045	1180
2700**	16	LXK8-PW27-0016	350	80	83	1380	1395	1650
2700**	24	LXK8-PW27-0024	350	80	83	1960	2090	2350
3000**	4	LXK8-PW30-0004	350	80	83	330	370	390
3000**	8	LXK8-PW30-0008	350	80	83	730	740	870
3000**	12	LXK8-PW30-0012	350	80	83	1070	1125	1280
3000**	16	LXK8-PW30-0016	350	80	83	1475	1500	1770
3000**	24	LXK8-PW30-0024	350	80	83	2100	2250	2520
4000**	4	LXK8-PW40-0004	350	80	83	380	410	450
4000**	8	LXK8-PW40-0008	350	80	83	780	815	930
4000**	12	LXK8-PW40-0012	350	80	83	1120	1240	1340
4000**	16	LXK8-PW40-0016	350	80	83	1590	1650	1900
4000**	24	LXK8-PW40-0024	350	80	83	2260	2475	2710

Notes for Table I:

1. Philips Lumileds maintains a tolerance of $\pm 6.5\%$ on luminous flux and ± 2 on CRI measurements.
2. * = High voltage multi-junction.
3. ** = Parts with original flux performance (before flux upgrade).

Product Selection Guide for LUXEON K Royal Blue, Junction Temperature = 85°C, Test Current = 350 mA

Table 2.

Color	Emitter Count	Part Number	Minimum Radiometric Power (mW)	Typical Radiometric Power (mW)	Maximum Radiometric Power (mW)	Typical Radiant Efficiency (%)
Royal Blue	8	LXK0-PR04-0008	4500	4670	5400	62%
Royal Blue	16	LXK0-PR04-0016	9000	9350	10800	62%

Optical Characteristics

LUXEON K White at Test Current, Junction Temperature = 85°C

Table 3.

Part Number	Nominal CCT	Color Temperature CCT	Typical Total Included Angle ^[2] (degrees) θ_{90V}	Typical Viewing Angle ^[2] (degrees) $2\theta_{1/2}$
		Typical		
LXKx-PW27-xxxx(A)	2700K	2725K	125	100
LXKx-PW30-xxxx(A)	3000K	3045K	125	100
LXKx-PW35-xxxx	3500K	3465K	125	100
LXKx-PW40-xxxx(A)	4000K	3985K	125	100
LXKx-PW50-xxxx	5000K	5028K	125	100

Notes for Table 3:

1. Total angle at which 90% of total luminous flux is captured.
2. Viewing angle is the off axis angle from lamp centerline where the luminous intensity is 1/2 of the peak value.

LUXEON K Royal Blue (LXK0-PRxx) at Test Current ^[1], Junction Temperature = 85°C

Table 4.

Part Color	Peak Wavelength, λ_p ^[2]			Typical Spectral Half-width (nm) ^[3] $\Delta\lambda_{1/2}$	Typical Temp Coefficient of Peak Wavelength (nm/°C) ^[4] $\Delta\lambda_{1/2}$	Typical Total Included Angle ^[4] (degrees) θ_{90V}	Typical Viewing Angle ^[5] (degrees) $2\theta_{1/2}$
	Min	Typ	Max				
Royal Blue	447.5nm	450nm	452.5nm	20	0.05	140	116

Notes for Table 4:

1. Test current is 350 mA for all LXK0-PRxx products.
2. Royal Blue product has single peak wavelength bin.
3. Spectral half-width is 1/2 of the peak intensity.
4. Total included angle at which 90% of total radiometric power is captured.
5. Viewing angle is the off-axis angle from lamp centerline where the luminous intensity is 1/2 of the peak value.

Electrical Characteristics

Electrical Characteristics at Test Current for LUXEON K White and Royal Blue, Junction Temperature = 85°C

Table 5.

Part Number	Forward Voltage V_f ^[1] (V)			Typical Temperature Coefficient of Forward Voltage ($\text{mV}/^\circ\text{C}$) $\Delta V_f / \Delta T_J$	Typical Thermal Resistance Junction to Case ($^\circ\text{C}/\text{W}$) $R_{\theta_{J-C}}$
	Minimum	Typical	Maximum		
LXKx-Pxxx-0403	30	31.5	33.8	-21.0	5.5
LXKx-Pxxx-xx04(A)	10	10.5	11.3	-6.3	3.0
LXKx-Pxxx-x404	40	42	45.1	-30.1	3.0
LXKx-Pxxx-xx08(A)	20	21	22.6	-12.5	1.5
LXKx-Pxxx-x206	30	31.5	33.8	-21.0	2.3
LXKx-Pxxx-xx12(A)	30	31.5	33.8	-18.8	1.0
LXKx-Pxxx-xx16(A)	40	42	45.1	-25.0	0.8
LXKx-Pxxx-xx24(A)	60	63	67.7	-37.5	0.5

Notes for Table 5:

1. Philips Lumileds maintains a tester tolerance of 0.5% on forward voltage measurements.
2. Junction temperature to back of the PCB.

Typical Electrical Characteristics at Twice the Test Current for LUXEON K White and Royal Blue, Junction Temperature = 85°C

Table 6.

Part Number	Typical Forward Voltage V_f (V)	Test Current (mA)
LXKx-Pxxx-x403	36	87.5
LXKx-Pxxx-xx04(A)	11	350
LXKx-Pxxx-x404	48	87.5
LXKx-Pxxx-xx08(A)	22	350
LXKx-Pxxx-x206	36	175
LXKx-Pxxx-xx12(A)	33	350
LXKx-Pxxx-xx16(A)	44	350
LXKx-Pxxx-xx24(A)	66	350

Absolute Maximum Ratings

Table 7.

Parameter	Maximum Performance		
	LXKx-Pxxx-x004/x006/x008/ x012/x016/x024	LXKx-Pxxx-x403/x404	LXKx-Pxxx-x206
DC Forward Current (mA)	1050	300	600
Peak Pulsed Forward Current (mA)	1050	300	600
ESD Sensitivity	< 8000V Human Body Model (HBM) Class 3A JESD22-A114-E < 400V Machine Model (MM) Class B JESD22-A115-B		
LED Junction Temperature ^[1]	125°C		
Operating Case Temperature	-40°C - 125°C		
Storage Temperature	-40°C - 125°C		
Reverse Voltage (V _r)	See Note 2		

Notes for Table 7:

1. Proper current derating must be observed to maintain junction temperature below the maximum.
2. LUXEON Power LEDs are not designed to be driven in reverse bias.

Electrical Lead Soldering Characteristics

Please refer to Application Brief ABI02 for LUXEON K.

Mechanical Dimensions

LXKx-Pxxx-xxx3

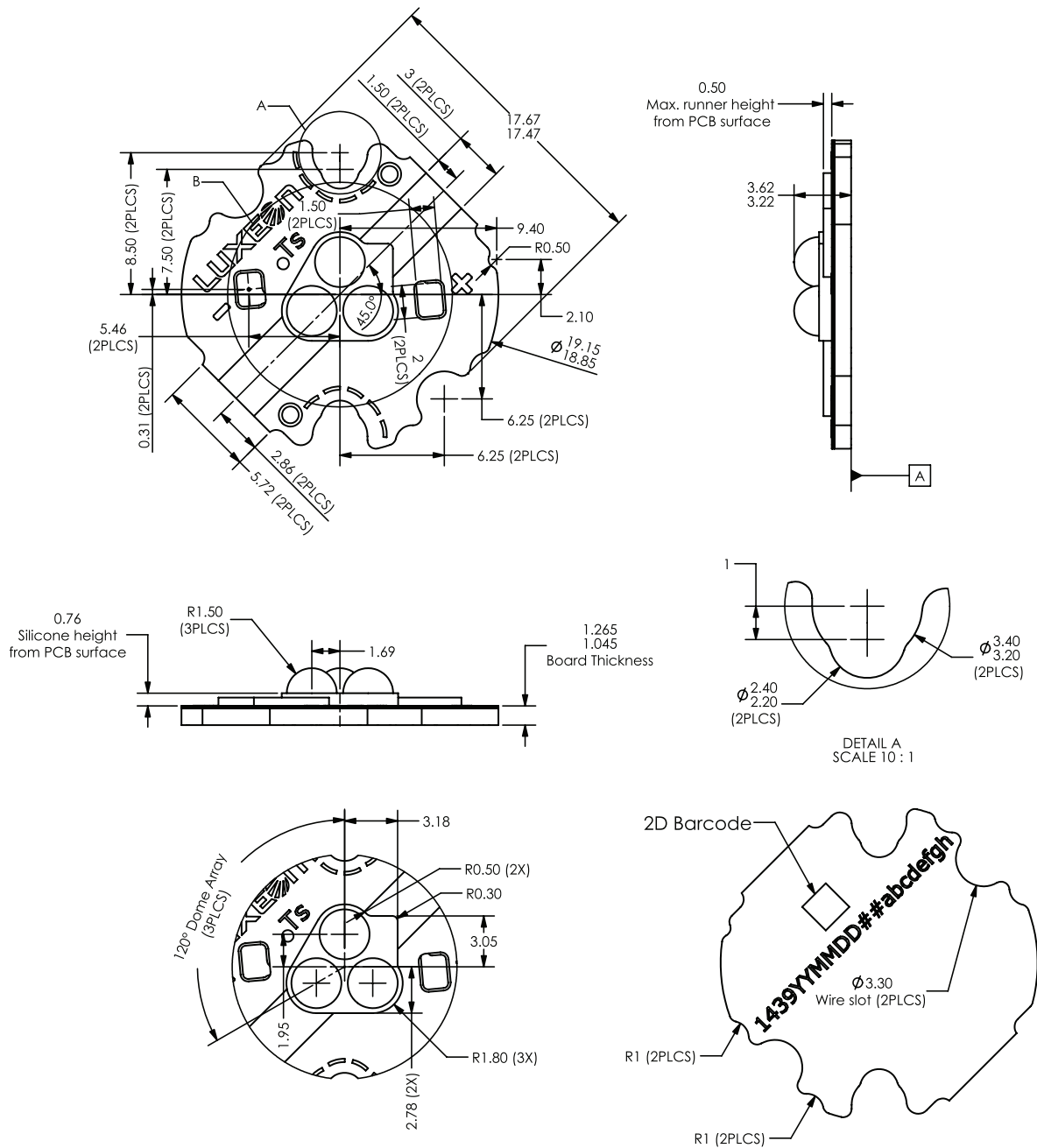

Figure 1. Dimensions for LXKx-Pxxx-xxx3.

Notes for Figure 1:

I. All dimensions are in millimeters.

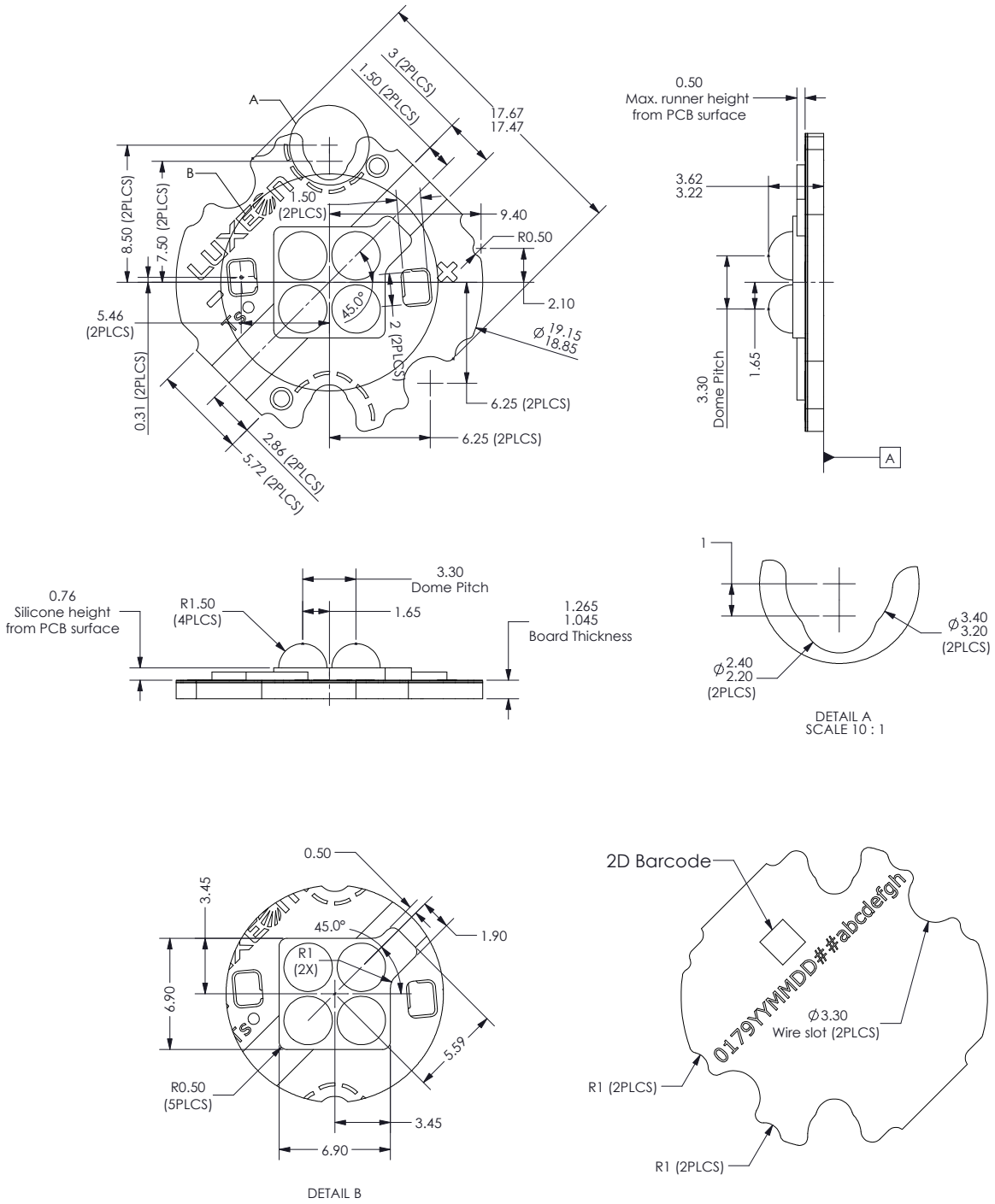

Figure 2. Dimensions for LXKx-Pxxx-xxx4(A).

Notes for Figure 2:

- I. All dimensions are in millimeters.

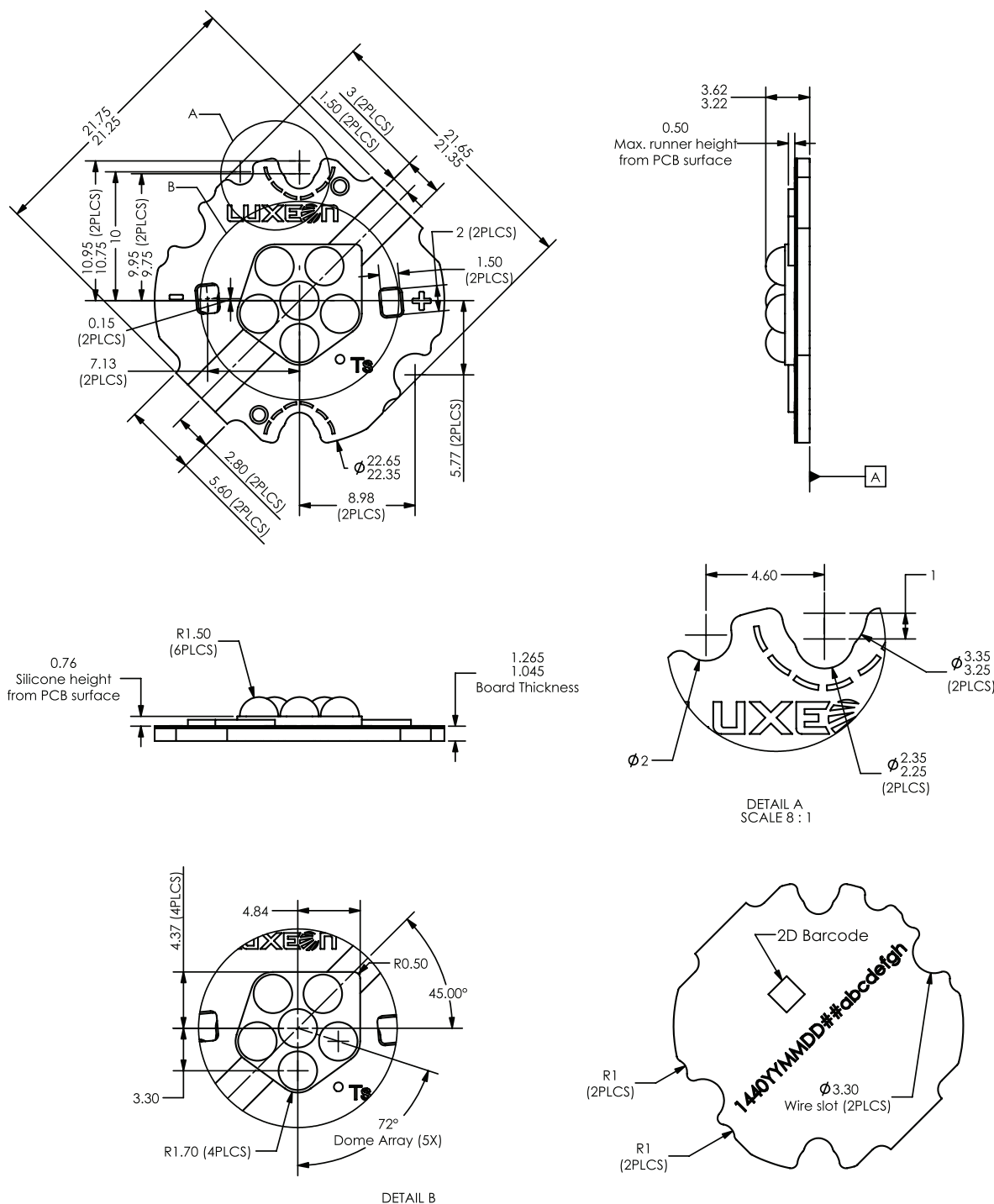

Figure 3. Dimensions for LXKx-Pxxx-xxx6.

Notes for Figure 3:

I. All dimensions are in millimeters.

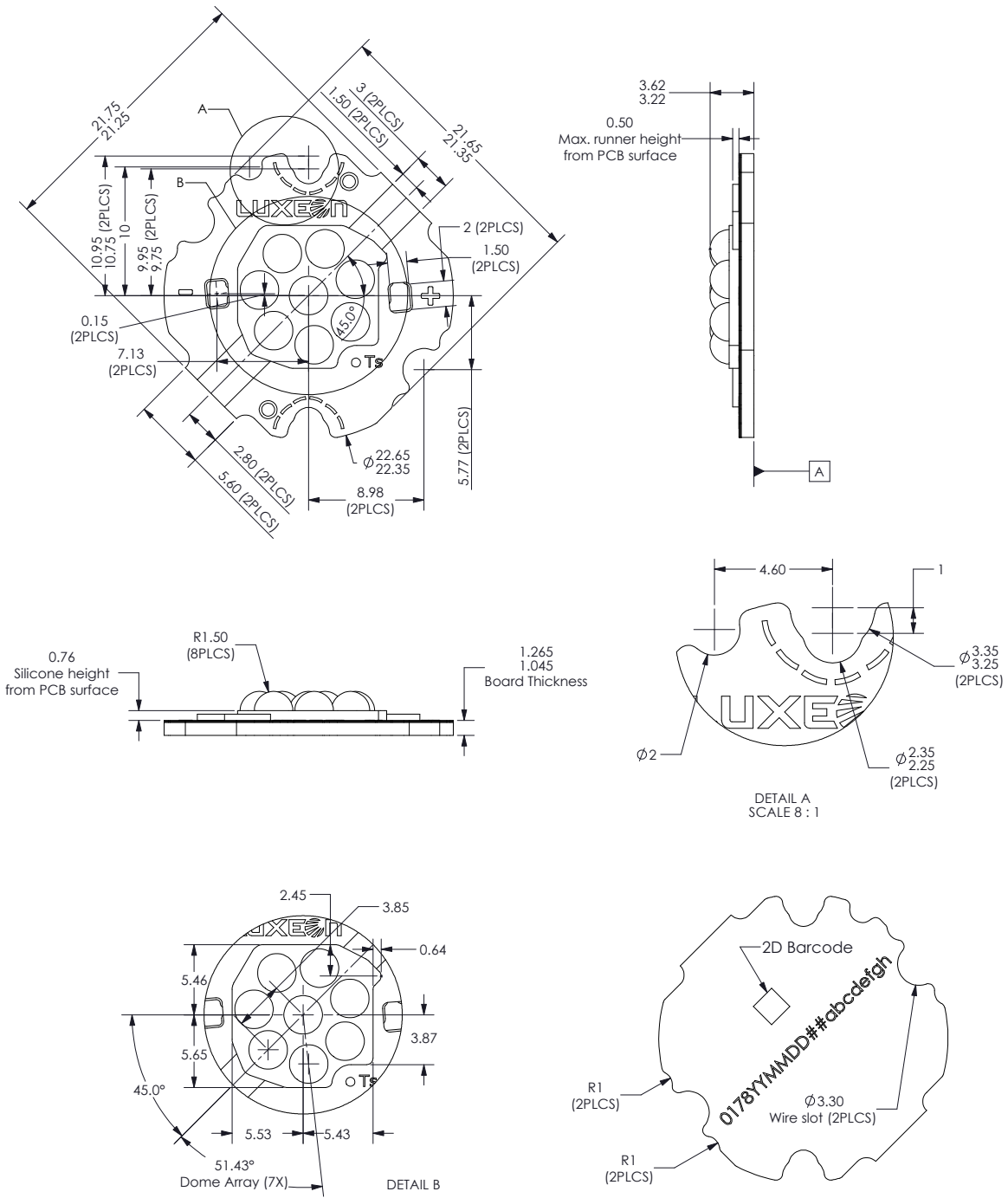

Figure 4. Dimensions for LXKx-Pxxx-xx08(A).

Notes for Figure 4:

- All dimensions are in millimeters.

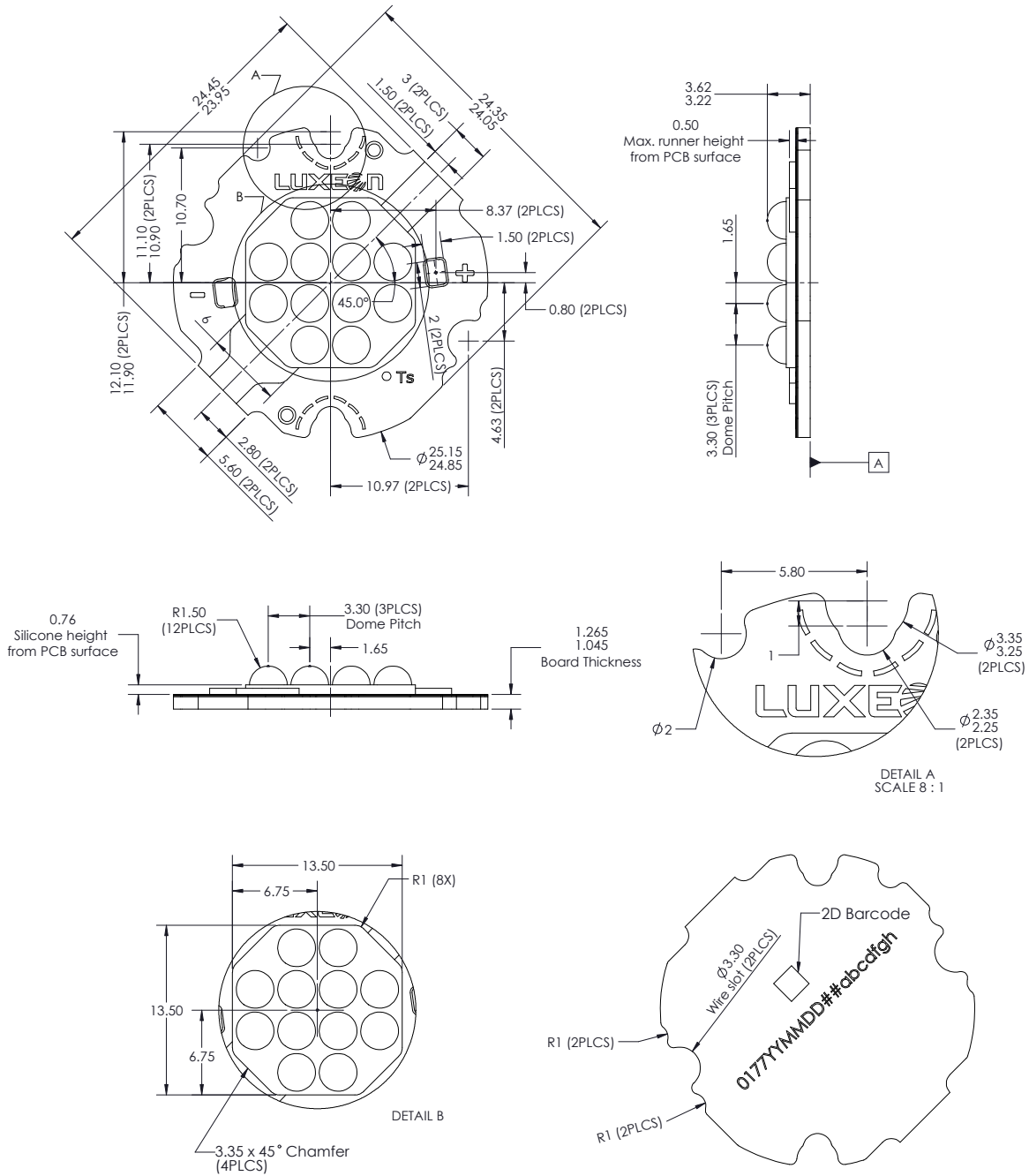

Figure 5. Dimensions for LXKx-Pxxx-xx12(A).

Notes for Figure 5:

- I. All dimensions are in millimeters.

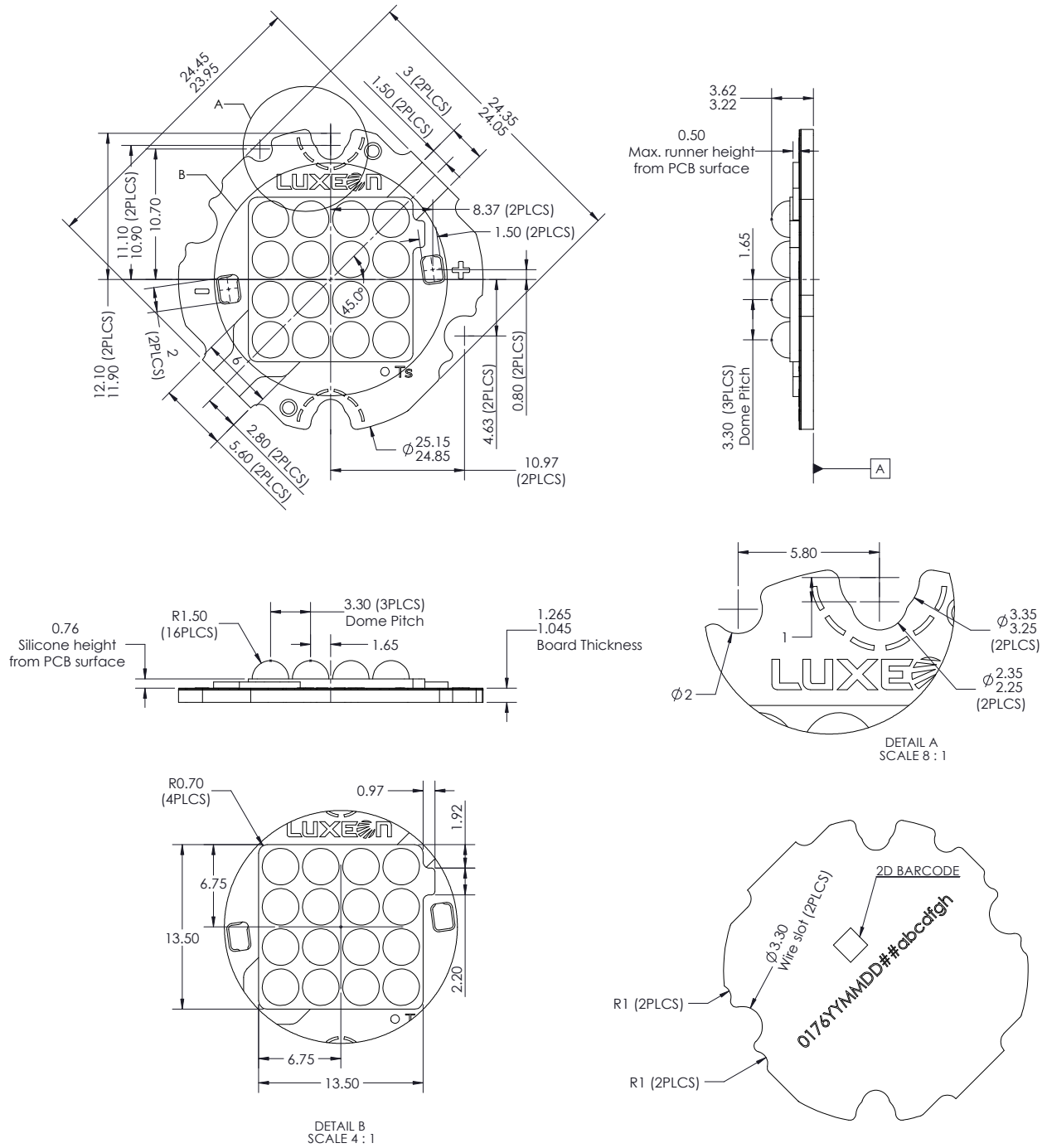

Figure 6. Dimensions for LXKx-Pxxx-xx16(A).

Notes for Figure 6:

- I. All dimensions are in millimeters.

Relative Spectral Distribution vs. Wavelength Characteristics

LXK8-PWxx-xxxx at Test Current, Junction Temperature = 85°C

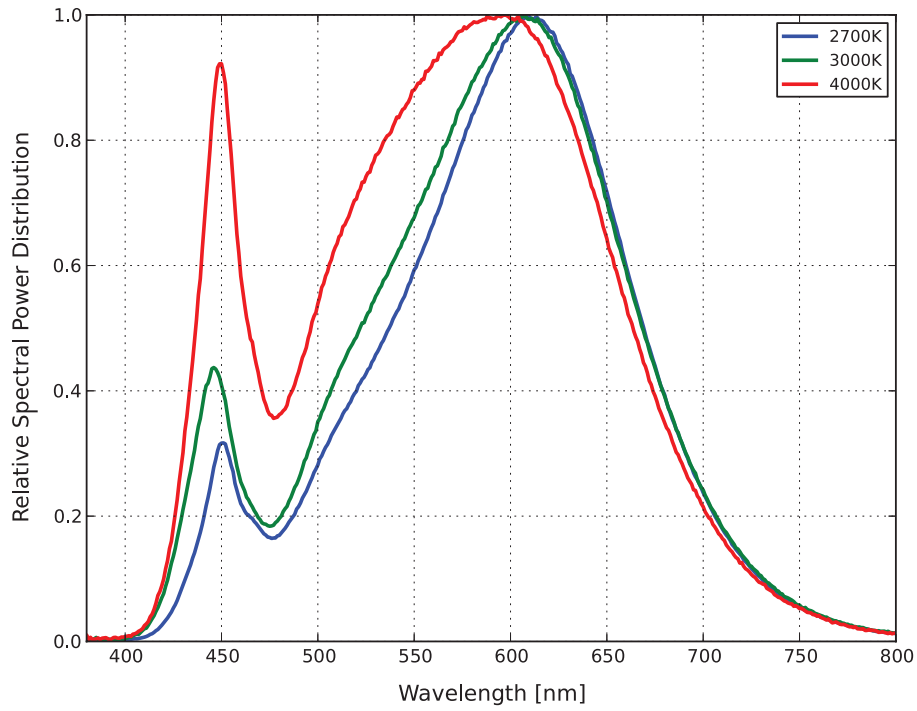

Figure 8. Color spectrum of LXK8-PWxx-xxxx product, integrated measurement.

LXK0-PR04-xxxx (Royal Blue) at Test Current, Junction Temperature = 85°C

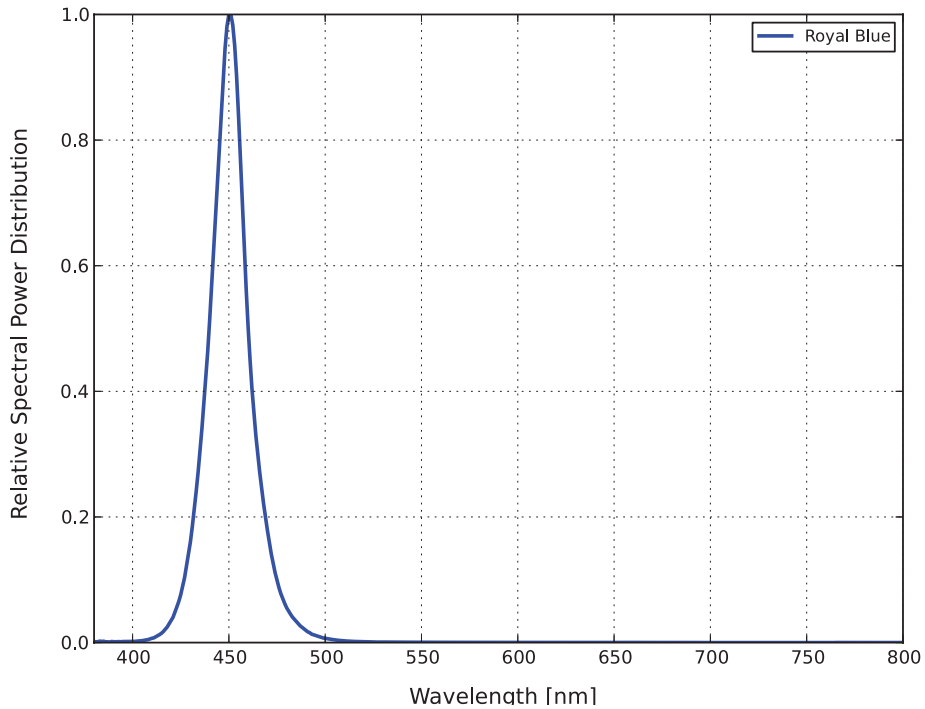

Figure 9. Color spectrum of LXK0-PR04-xxxx product, integrated measurement.

Light Output Characteristics over Temperature

All LUXEON K Products at Test Current, Normalized at Test Current,
Junction Temperature = 85°C

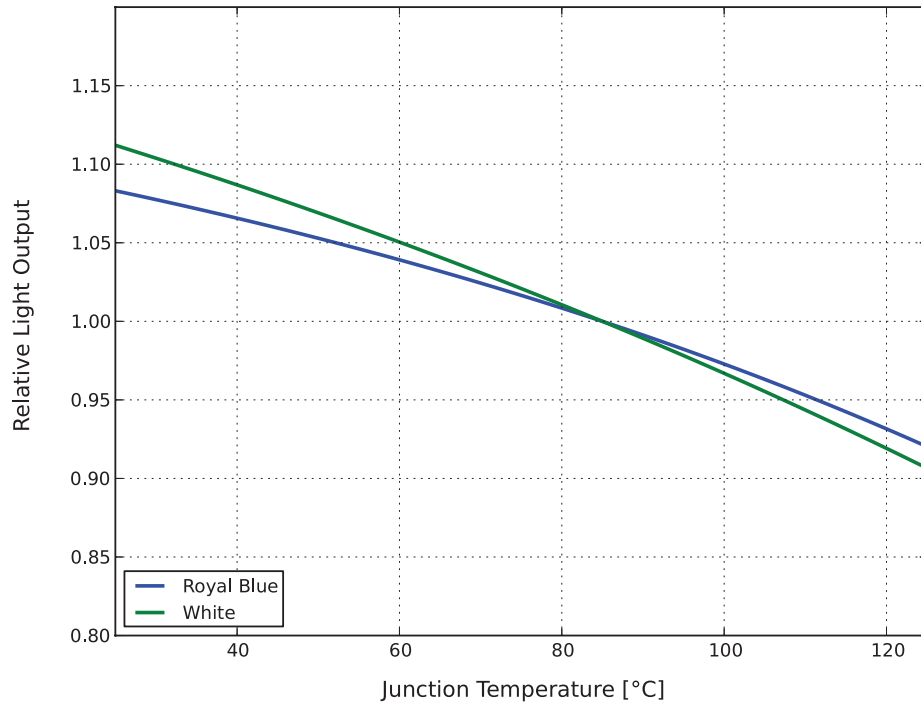

Figure 10. Typical relative flux vs. junction temperature at test current.

Typical Forward Current Characteristics

Typical Forward Current vs. Forward Voltage LUXEON K 3-up Products,
Junction Temperature = 85°C

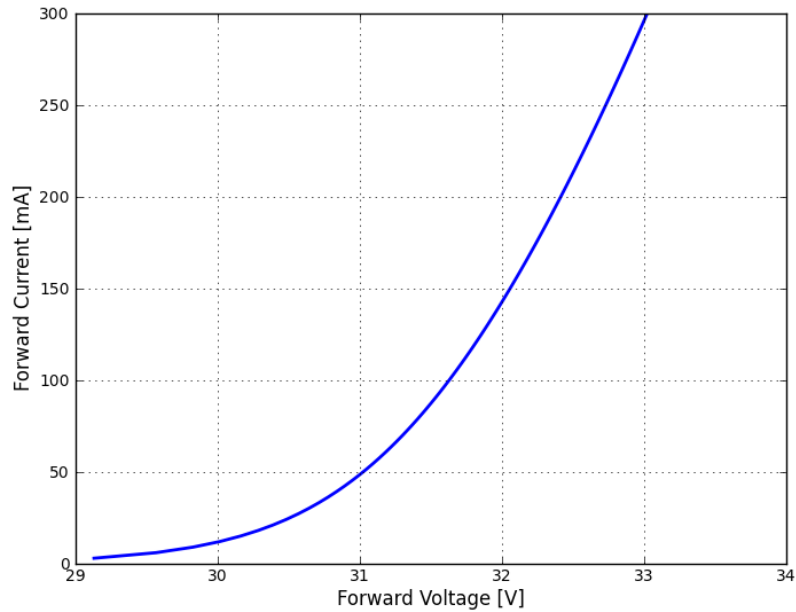

Figure 11. Forward current vs. forward voltage for LXXKx-Pxxx-x403 products.

Typical Forward Current vs. Forward Voltage LUXEON K 4-up Products,
Junction Temperature = 85°C

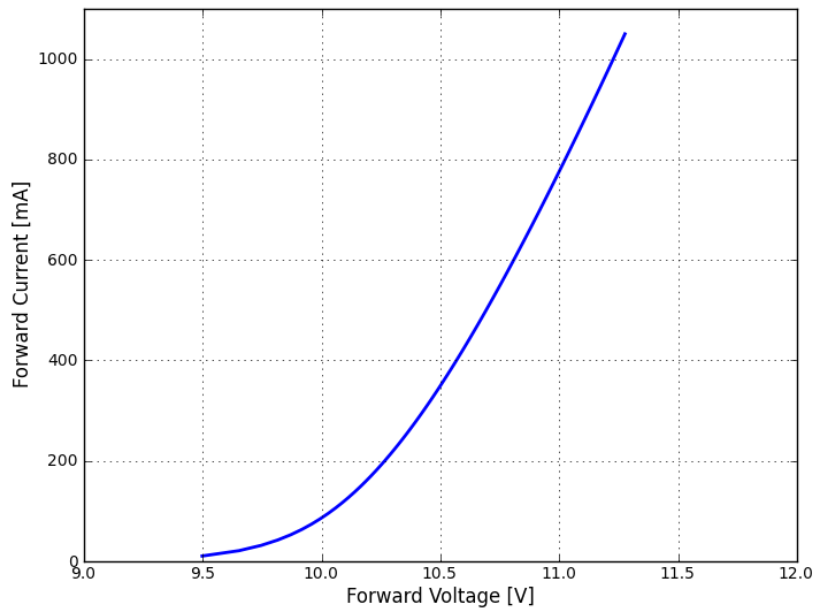

Figure 12. Forward current vs. forward voltage for LXXKx-Pxxx-0004(A) products.

Note for Figure 12:

1. LUXEON LXXKx-Pxxx-0004(A) is single junction product.

Typical Forward Current vs. Forward Voltage LUXEON K 4-up High-Voltage Products, Junction Temperature = 85°C

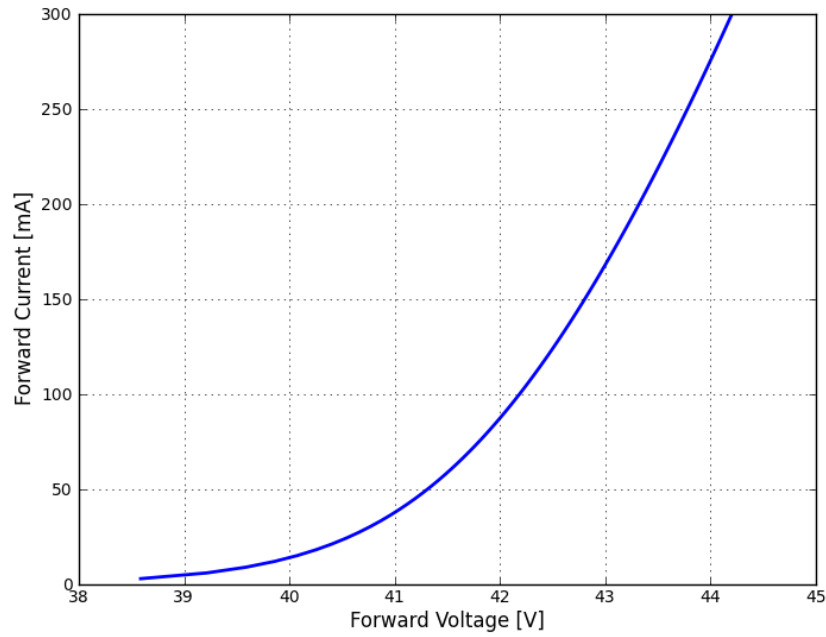

Figure 13. Forward current vs. forward voltage for LXXKx-Pxxx-x404 products.

Typical Forward Current vs. Forward Voltage LUXEON K 6-up High-Voltage Products, Junction Temperature = 85°C

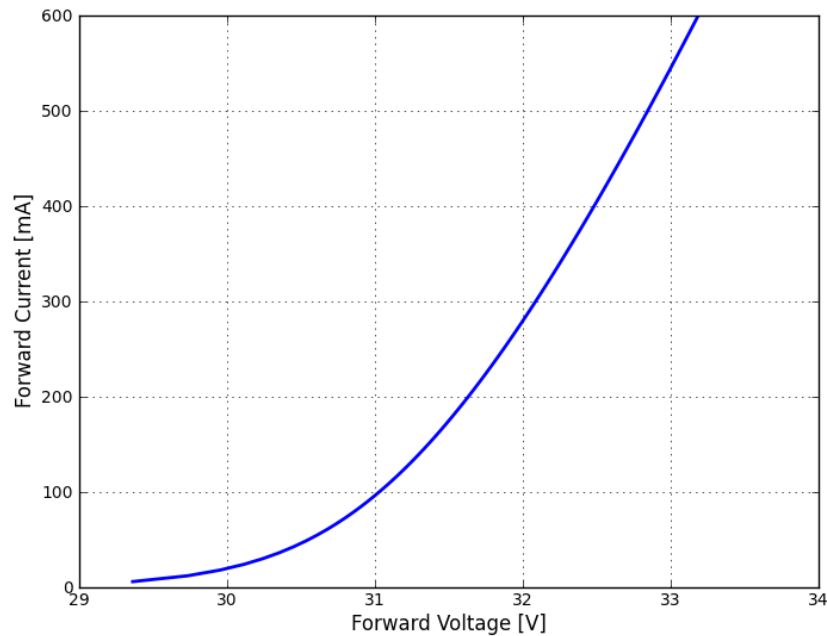

Figure 14. Forward current vs. forward voltage for LXXKx-Pxxx-x206 products.

Typical Forward Current vs. Forward Voltage LUXEON K 8-up Products, Junction Temperature = 85°C

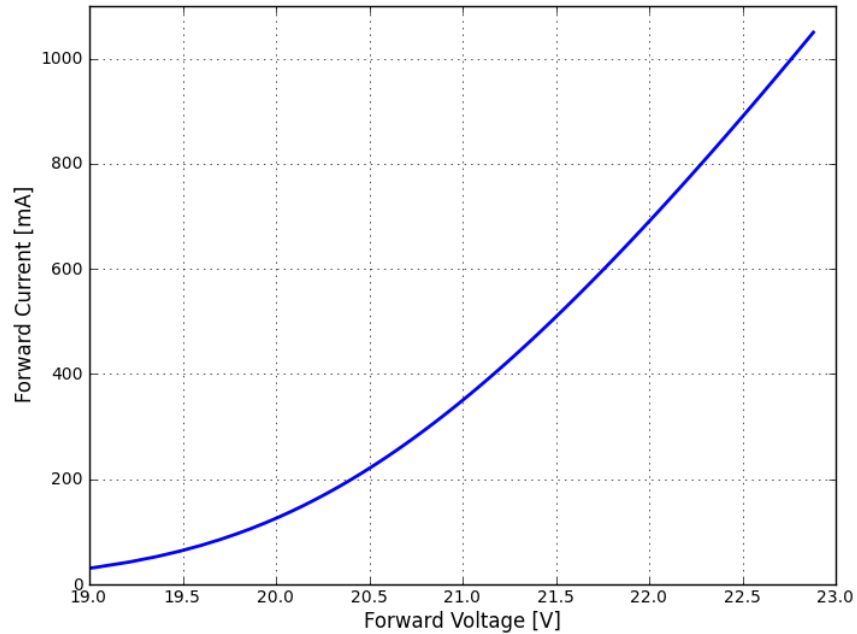

Figure 15. Forward current vs. forward voltage for LXXKx-Pxxx-xxx8(A) products.

Typical Forward Current vs. Forward Voltage LUXEON K 12-up Products, Junction Temperature = 85°C

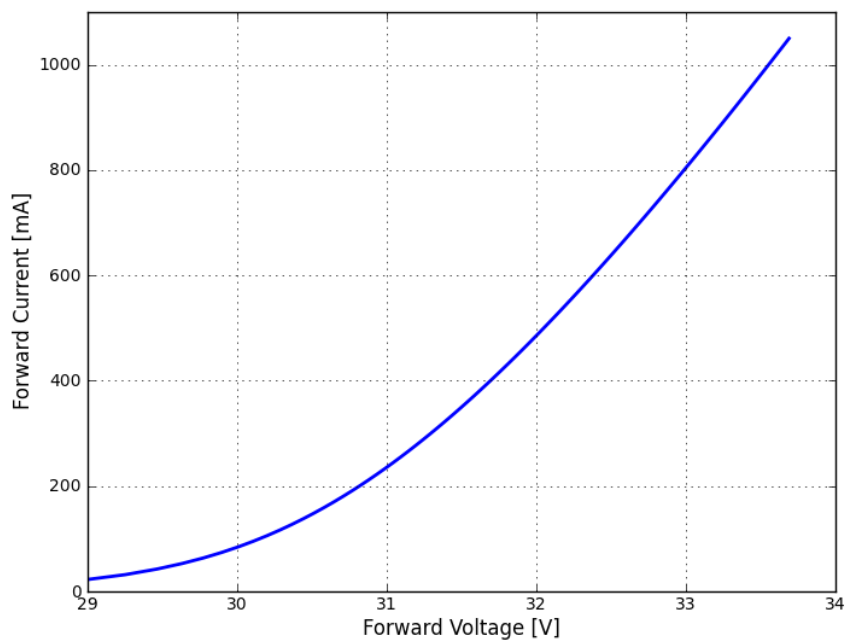

Figure 16. Forward current vs. forward voltage for LXXKx-Pxxx-xx12(A) products.

Typical Forward Current vs. Forward Voltage LUXEON K 16-up Products, Junction Temperature = 85°C

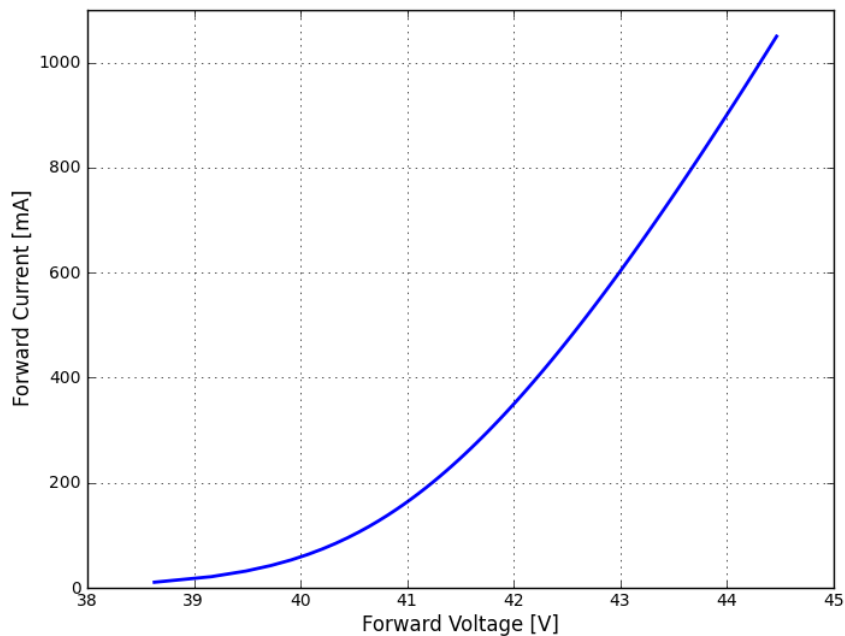

Figure 17. Forward current vs. forward voltage for LXXx-Pxxx-xx16(A) products.

Typical Forward Current vs. Forward Voltage LUXEON K 24-up Products, Junction Temperature = 85°C

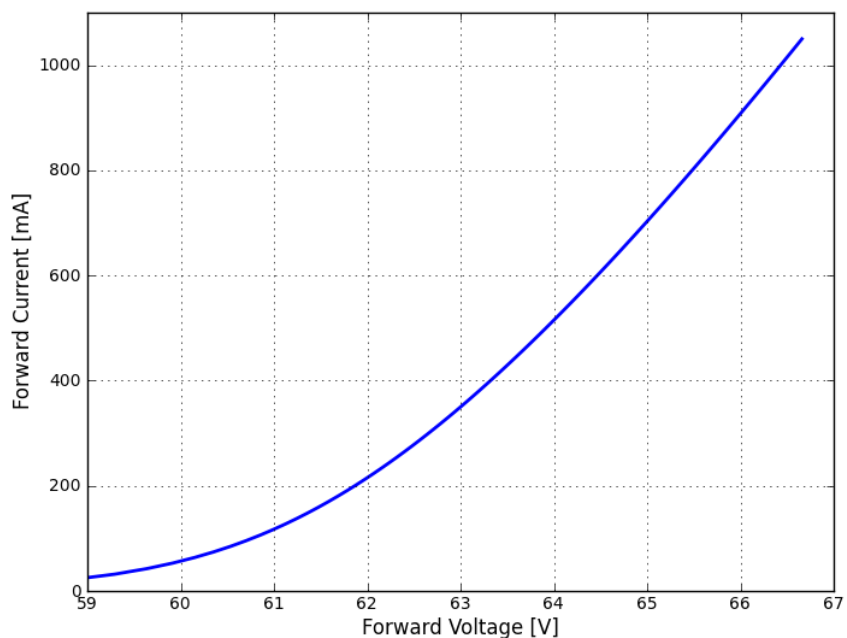

Figure 18. Forward current vs. forward voltage for LXXx-Pxxx-xx24(A) products.

Typical Relative Luminous Flux vs. Forward Current for ALL LUXEON K Product Configurations Without Multi-Junction Die, Junction Temperature 85°C

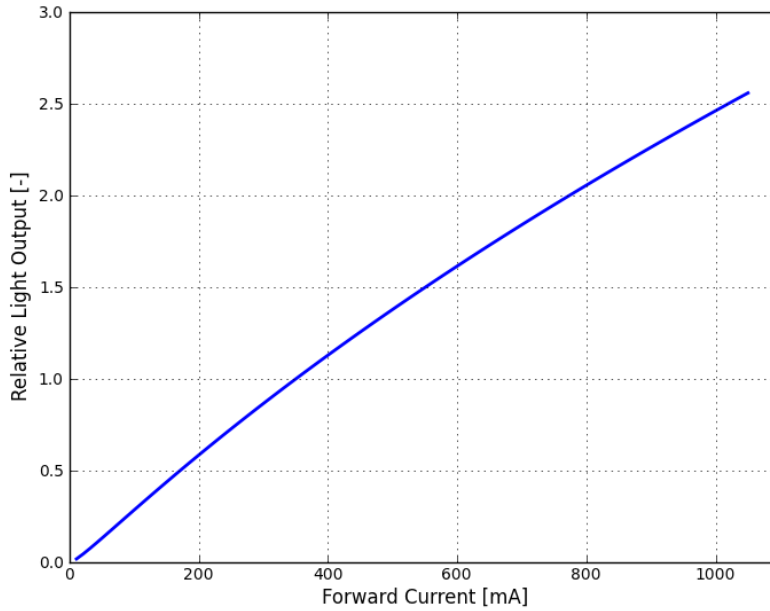

Figure 19. Typical relative luminous flux vs. forward current.

Typical Relative Luminous Flux vs. Forward Current for ALL LUXEON K Product Configurations With Multi-Junction Die, Junction Temperature 85°C

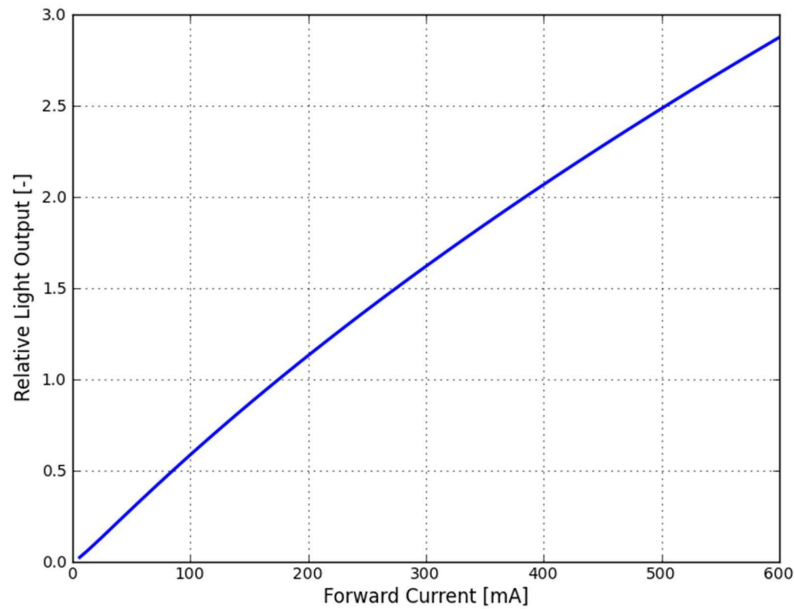

Figure 20. Typical relative luminous flux vs. forward current for LUXEON K (LXKx-PWxx-0206) with multi-junction die.

Typical Relative Luminous Flux vs. Forward Current for LUXEON K LXXx-PWxx-0403/ LXXx-PWxx-0404 Product Configurations With Multi-Junction Die, Junction Temperature 85°C

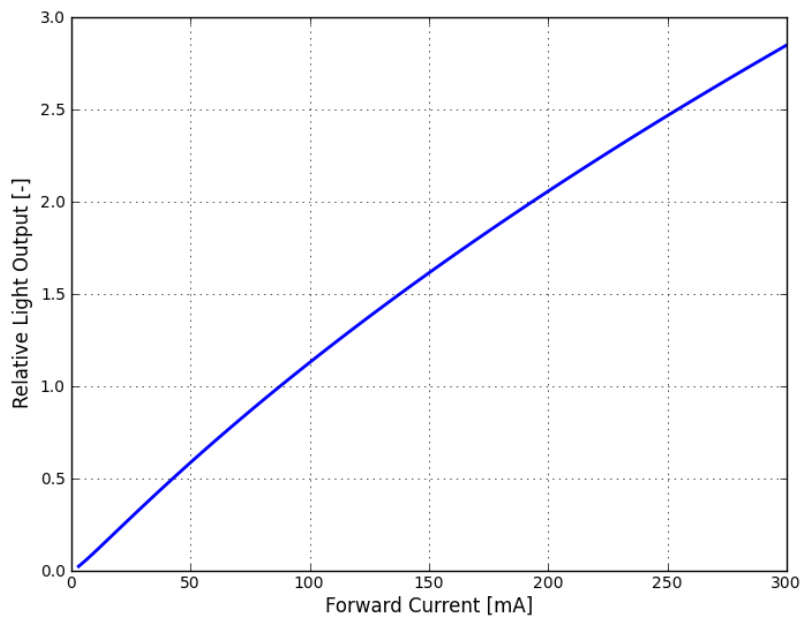

Figure 21. Typical relative luminous flux vs. forward current for LUXEON K (LXXx-PWxx-0403/LXXx-PWxx-0404) with multi-junction die.

Typical Radiation Patterns

Typical Spatial Radiation Pattern for LUXEON K

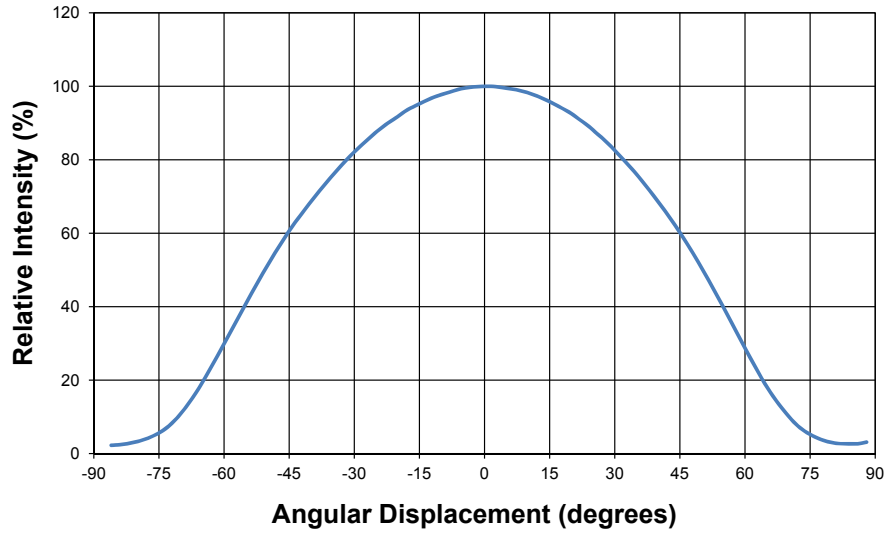

Figure 22. Typical representative spatial radiation pattern for LUXEON K.

Packaging on Trays

LUXEON K products will be securely packaged in trays.

Table 8.

Part Number	Tray Dimensions	Quantity per Tray	Number of Trays per Box
LXKx-Pxxx-xxx3 LXKx-Pxxx-xxx4(A)	315mm width x 135.9mm length x 12.11mm depth	40	10
LXKx-Pxxx-xxx6 LXKx-Pxxx-xxx8(A)	315mm width x 135.9mm length x 12.11mm depth	27	10
LXKx-Pxxx-xx12(A) LXKx-Pxxx-xx16(A)	315mm width x 135.9mm length x 12.11mm depth	24	10
LXKx-Pxxx-xx24	315mm width x 135.9mm length x 12.11mm depth	21	10

Tray Dimensions – LXXKx-Pxxx-xxx3 and LXXKx-Pxxx-xxx4(A)

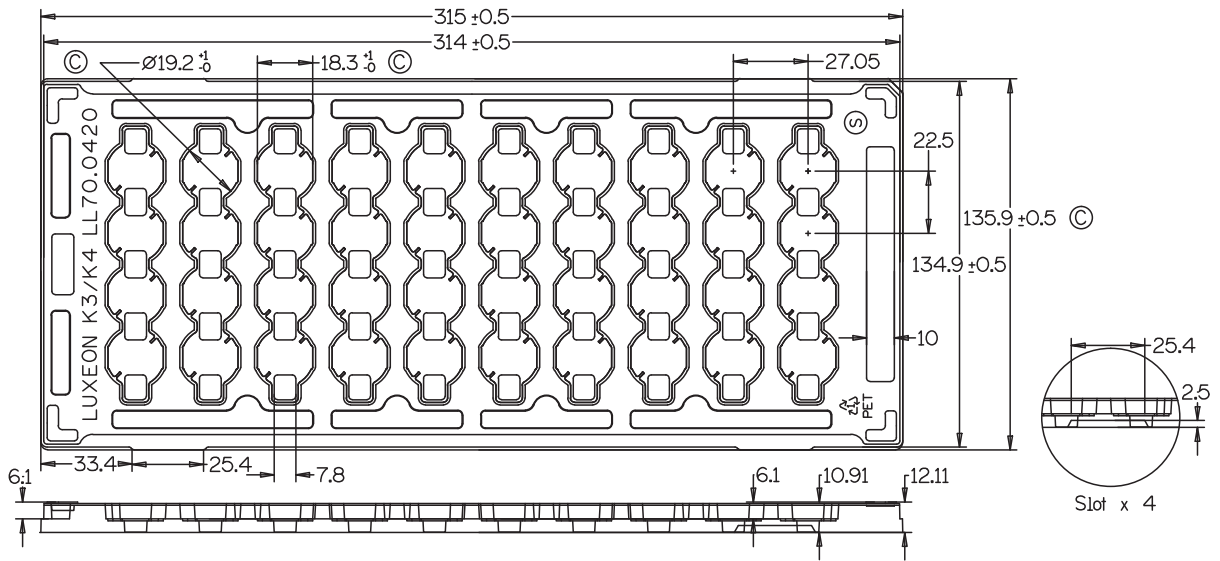

Figure 23.

Tray Dimensions – LXXKx-Pxxx-xxx6 and LXXKx-Pxxx-xxx8(A)

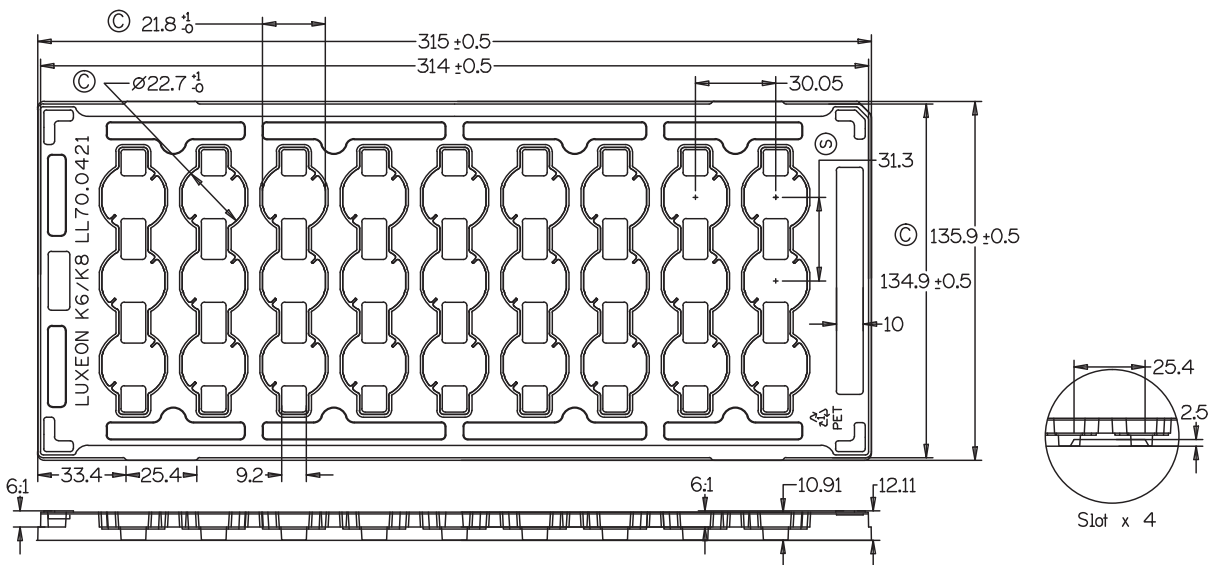

Figure 24.

Tray Dimensions – LXXKx-Pxxx-xx12(A) and LXXKx-Pxxx-xx16(A)

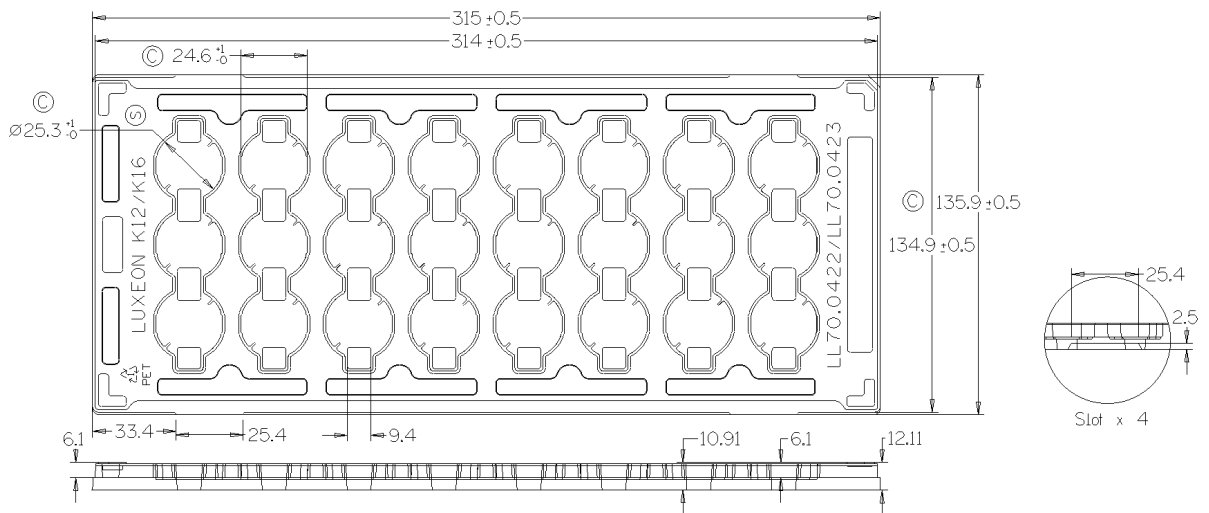

Figure 25.

Tray Dimensions – LXXKx-Pxxx-xx24(A)

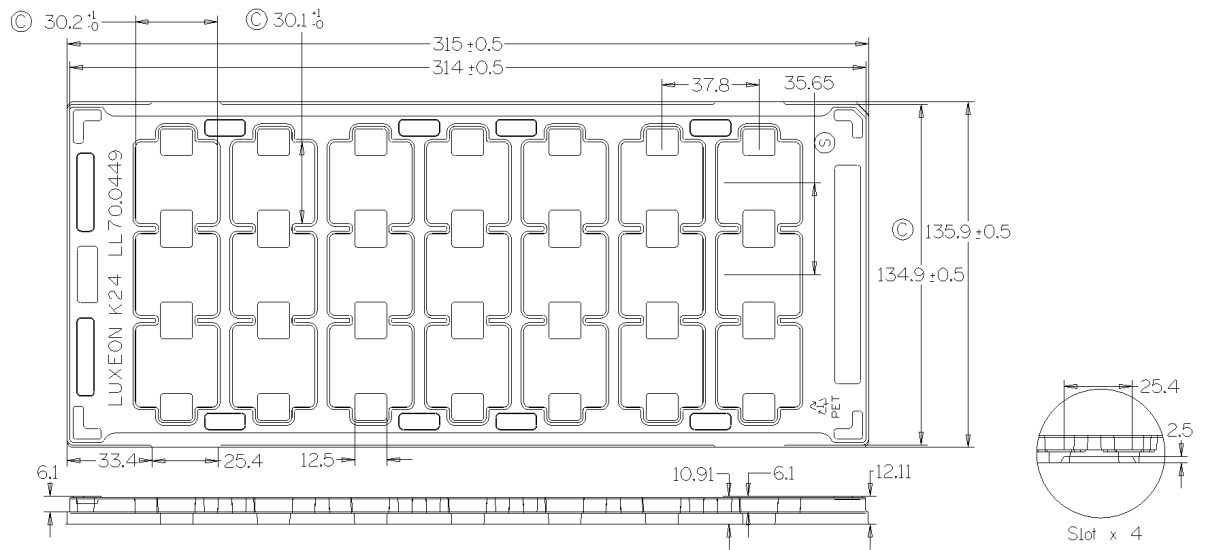

Figure 26.

LUXEON K White ANSI Color Bin Definition

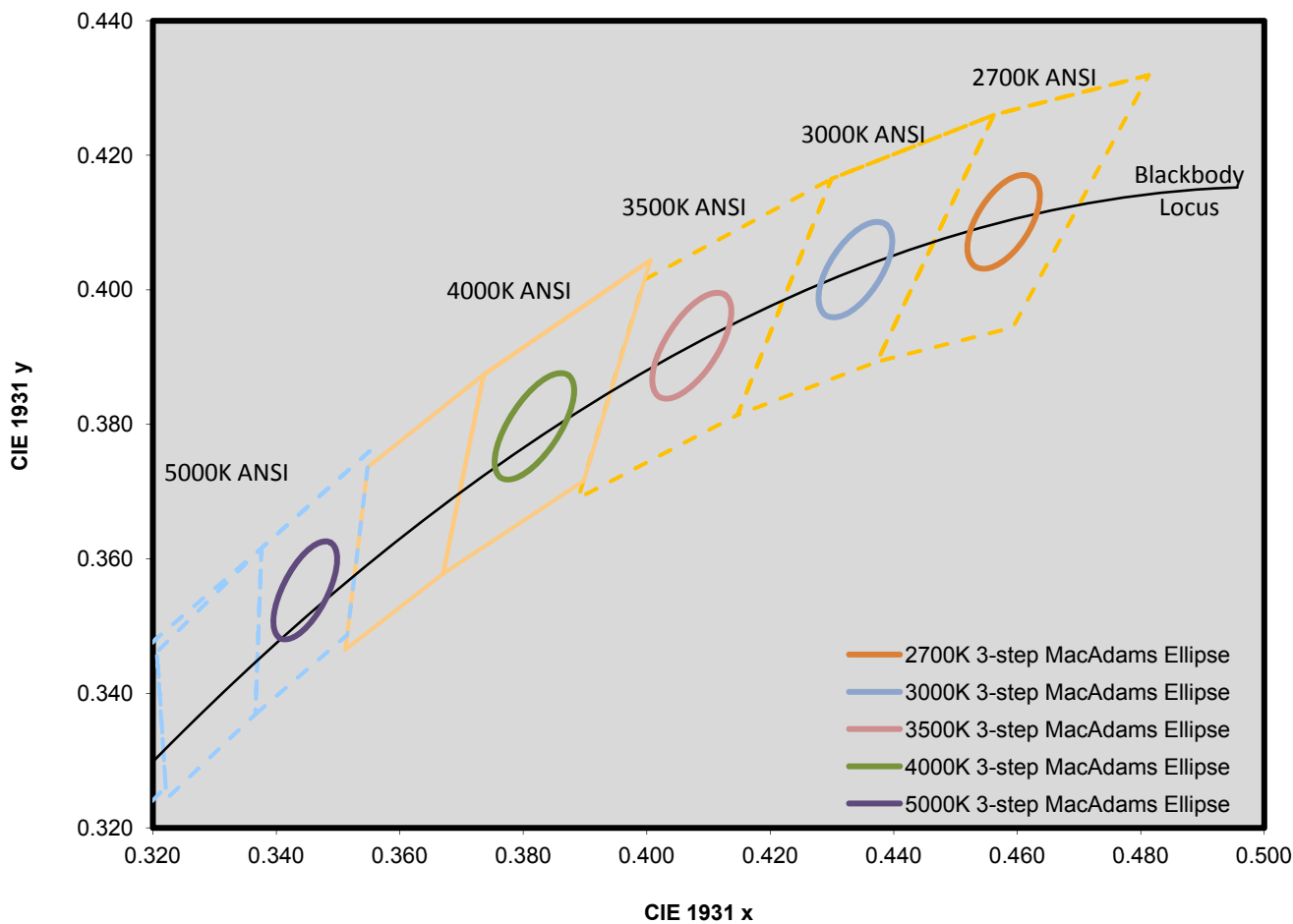

Figure 27. Graph of LUXEON K ANSI bin color definition.

Table 9. LUXEON K 3-step MacAdams Ellipse Color Definition

Nominal ANSI CCT	2700K	3000K	3500K	4000K	5000K
	Single 3-step MacAdam ellipse	Single 3-step MacAdam ellipse	Single 3-step MacAdam ellipse	Single 3-step MacAdam ellipse	Single 3-step MacAdam ellipse
Center Point (cx, cy) ¹⁾	(0.4578, 0.4101)	(0.4338, 0.4030)	(0.4073, 0.3917)	(0.3818, 0.3797)	(0.3447, 0.3553)
Major Axis, a	0.0081	0.00834	0.00927	0.00939	0.00822
Minor Axis, b	0.0042	0.00408	0.00414	0.00402	0.00354
Ellipse rotation angle	53.7°	53.22°	54.00°	53.72°	59.62°

Note for Table 9:

1. Philips Lumileds maintains a tester tolerance of ±0.005 on x, y color coordinates.

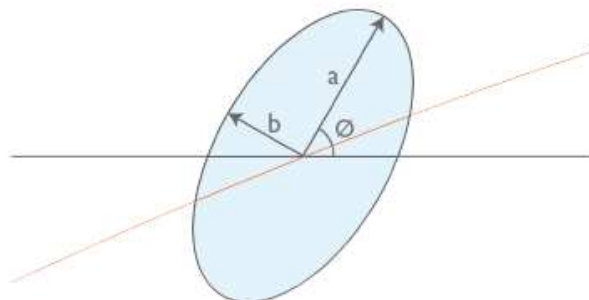

Who We Are

Philips Lumileds focuses on one goal: Creating the world's highest performing LEDs. The company pioneered the use of solid-state lighting in breakthrough products such as the first LED backlit TV, the first LED flash in camera phones, and the first LED daytime running lights for cars. Today we offer the most comprehensive portfolio of high quality LEDs and uncompromising service.

Philips Lumileds brings LED's qualities of energy efficiency, digital control and long life to spotlights, downlights, high bay and low bay lighting, indoor area lighting, architectural and specialty lighting as well as retrofit lamps. Our products are engineered for optimal light quality and unprecedented efficacy at the lowest overall cost. By offering LEDs in chip, packaged and module form, we deliver supply chain flexibility to the inventors of next generation illumination.

Philips Lumileds understands that solid state lighting is not just about energy efficiency. It is about elegant design. Reinventing form. Engineering new materials. Pioneering markets and simplifying the supply chain. It's about a shared vision. Learn more about our comprehensive portfolio of LEDs at www.philipslumileds.com.

Philips Lumileds Lighting Company shall not be liable for any kind of loss of data or any other damages, direct, indirect or consequential, resulting from the use of the provided information and data. Although Philips Lumileds Lighting Company has attempted to provide the most accurate information and data, the materials and services information and data are provided "as is" and Philips Lumileds Lighting Company neither warranties, nor guarantees the contents and correctness of the provided information and data. Philips Lumileds Lighting Company reserves the right to make changes without notice. You as user agree to this disclaimer and user agreement with the download or use of the provided materials, information and data.



©2013 Philips Lumileds Lighting Company. All rights reserved.
LUXEON is a registered trademark of the Philips Lumileds Lighting Company in the United States and other countries.

www.philipslumileds.com
www.philipslumileds.cn.com

LUXEON K Datasheet DS102 20131014