

LUXEON Q

Industry Standard 3535 Footprint Delivering
High Efficacy at High Drive Current

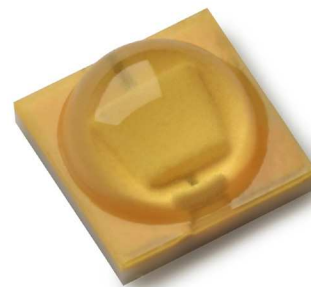

Introduction

LUXEON® Q delivers superior performance in a high power emitter that serves as a direct drop-in replacement for products that use the standard 3535 surface mount package. LUXEON Q is the first high-power LED based on LUXEON Flip Chip die, Philips Lumileds high performance Chip Scale Package (CSP) device architecture.

The LUXEON Q takes advantage of a fully developed ecosystem for 3535 components, including optics, to speed the time-to-market for indoor and outdoor luminaires.

Features

- Industry standard 3535 package
- LUXEON Flip Chip, high performance Chip Scale Package (CSP) LED
- High efficacy at high drive current
- *Freedom from Binning* - 3 & 5 SDCM
- Hot tested at $T_j = 85^{\circ}\text{C}$
- UL-recognized component [E352519] with level 4 enclosure consideration

Benefits

- Faster time to market
- Industry leading performance
- High lumen and lm/\$ at high lm/W
- Delivers color consistency

Key Applications

- Downlights
- High bay & Low bay
- Lamps
- Outdoor
 - Outdoor Area
 - Roadway & Parking
 - Tunnel
- Specialty

Table of Contents

General Information	2
Product Nomenclature	2
Average Lumen Maintenance Characteristics	2
Environmental Compliance	2
Product Selection & Optical Characteristics	3
Electrical Characteristics	4
Absolute Maximum Ratings	4
JEDEC Moisture Sensitivity	5
Reflow Soldering Characteristics	5
Mechanical Dimensions	6
Solder Pad Design	7
Relative Spectral Distribution vs. Wavelength Characteristics	8
Typical Light Output Characteristics	9
Typical Forward Current Characteristics	10
Typical Radiation Patterns	11
Emitter Pocket Tape Packaging	12
Emitter Reel Packaging	13
Product Binning and Labeling	14
Luminous Flux and Forward Voltage Bins	15
LUXEON Q 3-step and 5-step MacAdam Ellipse Color Definition	16

General Information

Product Nomenclature

LUXEON Q emitters are specified and binned “hot” under conditions comparable to those found in “real-world” lighting products. The test conditions for LUXEON Q are 350 mA DC with junction temperature at 85°C.

The part number designation is explained as follows:

L I Q 0 - x x y 0 0 0 0 0 z z z 0

Where:

- xx — designates nominal ANSI CCT (27 for 2700K, 30 for 3000K)
- yy — designates minimum CRI performance (70 for 70 CRI, 80 for 80 CRI)
- zzz — designates minimum flux performance at standard binning current and temperature (090 for 90lm, 110 for 110lm, etc)

Therefore, 80 CRI products tested and binned at 3000K with a 100lm minimum flux at binning current and temperature will have the part numbering scheme:

L I Q 0-3080000001000

Therefore, 70 CRI products tested and binned at 5700K with a 120lm minimum flux at binning current and temperature will have the following part numbering scheme:

L I Q 0-5770000001200

Average Lumen Maintenance Characteristics

LUXEON Q products are tested in compliance with LM-80. Please visit www.philipslumileds.com/support/documentation/lumen-maintenance or contact your local Philips Lumileds Technical Solutions Manager for TM-21 extrapolations or other support.

Environmental Compliance

Philips Lumileds is committed to providing environmentally friendly products to the solid-state lighting market. LUXEON Q is compliant to the European Union directives on the restriction of hazardous substances in electronic equipment, namely the RoHS and REACH directives. Philips Lumileds will not intentionally add the following restricted material to the LUXEON Q: lead, mercury, cadmium, hexavalent chromium, polybrominated biphenyls (PBB) or polybrominated diphenyl ethers (PBDE).

Product Selection & Optical Characteristics

Product Selection Guide for LUXEON Q Emitters Junction Temperature = 85°C

Table 1.

Typical Performance Characteristics at 350 mA, 700 mA, and 1000 mA for LUXEON Q, Junction Temperature = 85°C												
Part Number	Nominal ANSI CCT	CRI	Luminous Flux (lm) Min	Typical Luminous Flux (lm)			Typical Forward Voltage (V _f)			Typical Efficacy (lm/W)		
				700 mA	350 mA	350 mA	700 mA	1000 mA	350 mA	700 mA	1000 mA	350 mA
LIQ0-278000000zzz0	2700K	80 min	80	100	177	231	2.81	2.93	2.99	102	86	77
LIQ0-308000000zzz0	3000K	80 min	90	102	183	240	2.81	2.93	2.99	104	89	80
LIQ0-358000000zzz0	3500K	80 min	90	106	189	251	2.81	2.93	2.99	108	92	84
LIQ0-407000000zzz0	4000K	70 min	110	123	220	293	2.81	2.93	2.99	125	107	98
LIQ0-577000000zzz0	5700K	70 min	110	127	229	305	2.81	2.93	2.99	129	112	102

Notes for Table 1:

1. Philips Lumileds maintains a tolerance of ± 6.5% on luminous flux and ± 2 on CRI measurements.

Optical Characteristics

LUXEON Q at Test Current ^[1], Junction Temperature = 85°C

Table 2.

Nominal ANSI CCT	Part Number	Typical Color Temperature CCT	Typical Total Included Angle ^[2] (degrees) $\theta_{0.90v}$	Typical Viewing Angle ^[3] (degrees) $2\theta_{1/2}$
2700K	LIQ0-278000000zzz0	2725K	160	135
3000K	LIQ0-308000000zzz0	3045K	160	135
3500K	LIQ0-358000000zzz0	3465K	160	135
4000K	LIQ0-407000000zzz0	3985K	160	135
5700K	LIQ0-577000000zzz0	5665K	160	135

Notes for Table 2:

1. Test current is 350 mA D.C. for all LIQ0-xyy00000zzz0 emitters.
2. Total angle at which 90% of total luminous flux is captured.
3. Viewing angle is the off axis angle from lamp centerline where the luminous intensity is ½ of the peak value.

Electrical Characteristics

Electrical Characteristics at test current for LUXEON Q

Junction Temperature = 85°C

Table 3.

Nominal ANSI CCT	Forward Voltage V_f (V) ^[1]		Typical Temperature Coefficient of Forward Voltage ^[2] (mV/°C) $\Delta V_f / \Delta T_j$	Typical Thermal Resistance Junction to Thermal Pad (°C/W) $R\theta_{j-c}$
	Minimum	Maximum		
2700K	2.75	3.25	-1.6	7
3000K	2.75	3.25	-1.6	7
3500K	2.75	3.25	-1.6	7
4000K	2.75	3.25	-1.6	7
5700K	2.75	3.25	-1.6	7

Notes for Table 3:

1. Philips Lumileds maintains a tolerance of $\pm 0.06V$ on forward voltage measurements.
2. Measured between $T_j = 25^\circ C$ and $T_j = 110^\circ C$ at $I_f = 350$ mA.

Absolute Maximum Ratings

Table 4.

Parameter	LUXEON Q
DC Forward Current (mA) ^{[1][2]}	1050
Peak Pulsed Forward Current (mA) ^{[1][3]}	1200
ESD Sensitivity	< 8000V Human Body Model (HBM) Class 3A JESD22-A114-E
LED Junction Temperature ^[1]	135°C
Operating Case Temperature at 700 mA	-40°C - 135°C
Storage Temperature	-40°C - 135°C
Soldering Temperature	JEDEC 020c 260°C
Allowable Reflow Cycles	3
Reverse Voltage (Vr) ^{[4][5]}	LUXEON Q LEDs are not designed to be driven in reverse bias

Notes for Table 4:

1. Proper current derating must be observed to maintain junction temperature below the maximum. For additional information on thermal measurement guidelines please refer to Application Brief ABI 18 (not available yet).
2. Residual periodic variations due to power conversion from alternating current (AC) to direct current (DC), also called "ripple", with frequencies ≥ 100 Hz and amplitude ≤ 150 mA are acceptable, assuming the average current throughout each cycle does not exceed 1050 mA.
3. Pulsed operation with a peak drive current of 1200 mA is acceptable if the pulse on-time is ≤ 5 ms per cycle and the duty cycle is $\leq 50\%$
4. Transient reverse voltages and surge currents due to electrical switching or supply interruptions are acceptable if these events do not last for more than 10ms, the amplitude of the reverse voltage does not exceed 5V and the reverse current is less than 200 μA .
5. Max 5V reverse for up to 10s is an acceptable beginning of life, one time test condition.

JEDEC Moisture Sensitivity

Table 5.

Level	Floor Life		Soak Requirements Standard	
	Time	Conditions	Time	Conditions
I	unlimited	30°C / 85% RH	168h + 5 / - 0	85°C / 85% RH

Reflow Soldering Characteristics

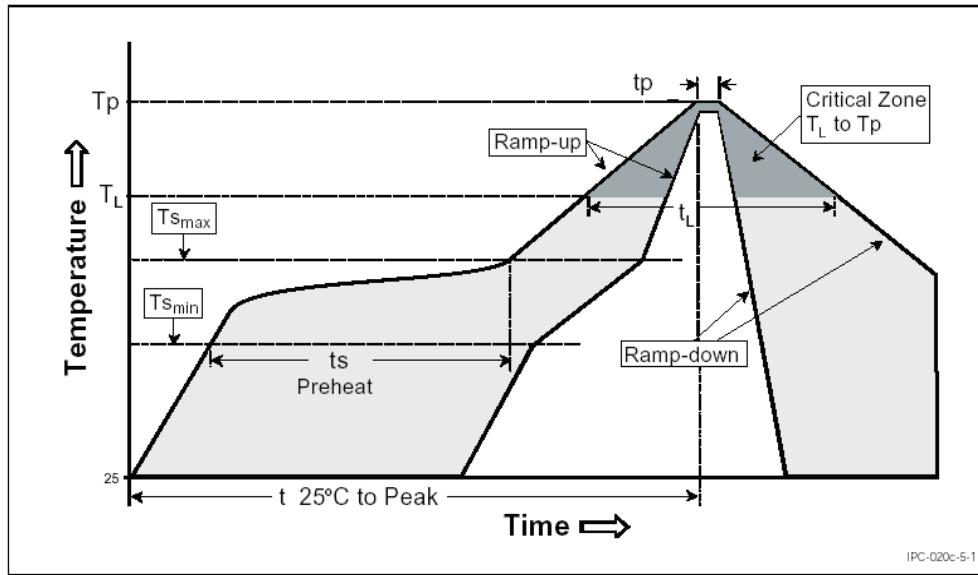

Figure 1. Temperature Profile for Table 6.

Table 6.

Profile Feature	Lead Free Assembly
Average Ramp-Up Rate ($T_{s_{max}}$ to T_p)	3°C / second max
Preheat Temperature Min ($T_{s_{min}}$)	150°C
Preheat Temperature Max ($T_{s_{max}}$)	200°C
Preheat Time ($t_{s_{min}}$ to $t_{s_{max}}$)	60 - 180 seconds
Time Maintained Above Temperature T_L	217°C
Time Maintained Above Time (t_L)	60 - 150 seconds
Peak / Classification Temperature (T_p)	260°C
Time Within 5°C of Actual Peak Temperature (t_p)	20 - 40 seconds
Ramp-Down Rate	6°C / second max
Time 25°C to Peak Temperature	8 minutes max

Mechanical Dimensions

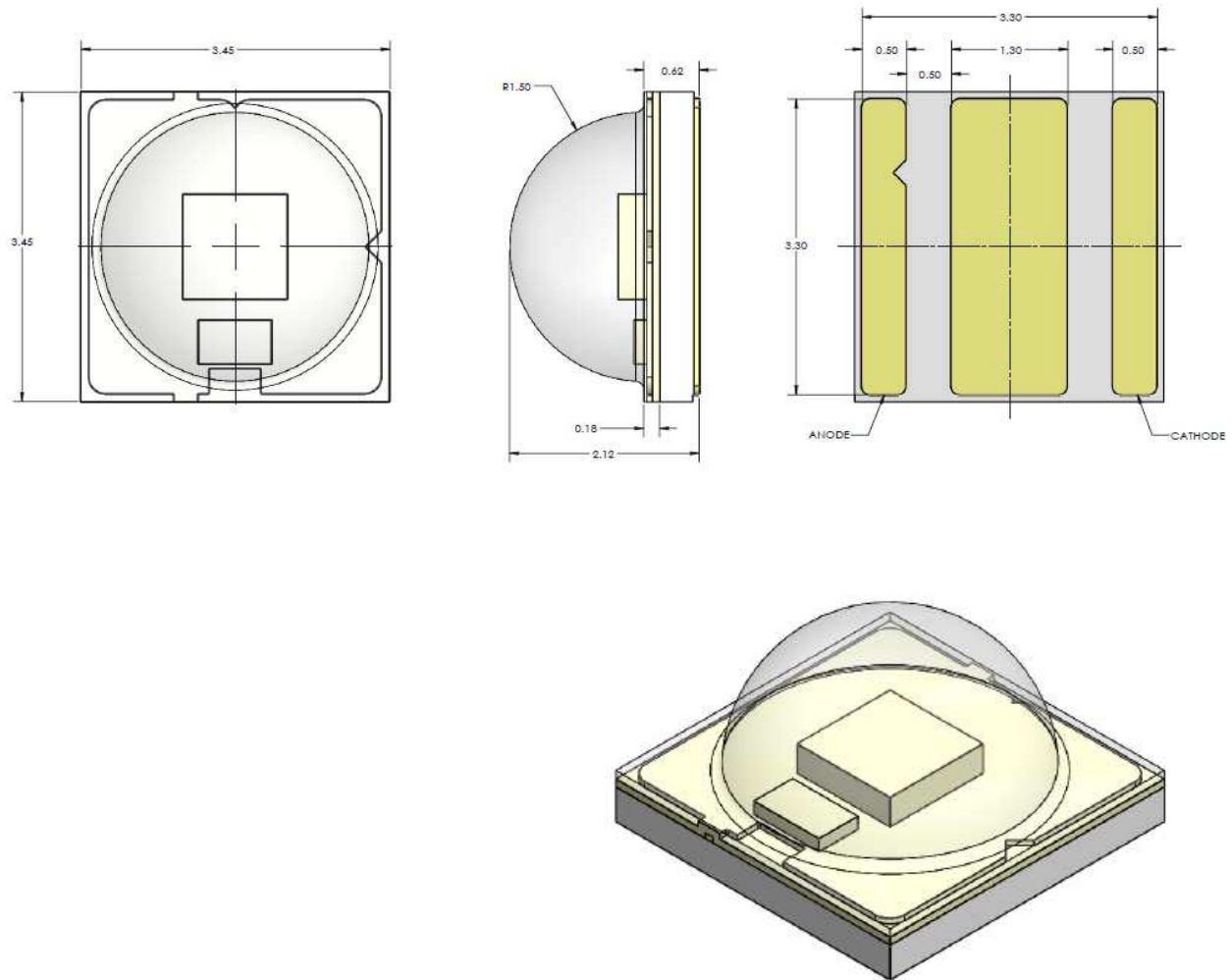

Figure 2. Package outline drawing for LUXEON Q.

Notes for Figure 2:

1. Drawings not to scale.
2. All dimensions are in millimeters.
3. The thermal pad is electrically isolated from the anode and cathode contact pads.
4. Do not handle the device by the lens. Excessive force on the lens may damage the lens itself or the interior of the device.
5. Tolerances (UNLESS OTHERWISE SPECIFIED)
 - LINEAR: ANGULAR:
 - XX, ± 0.125 mm XX $\pm 1^\circ$

Solder Pad Design

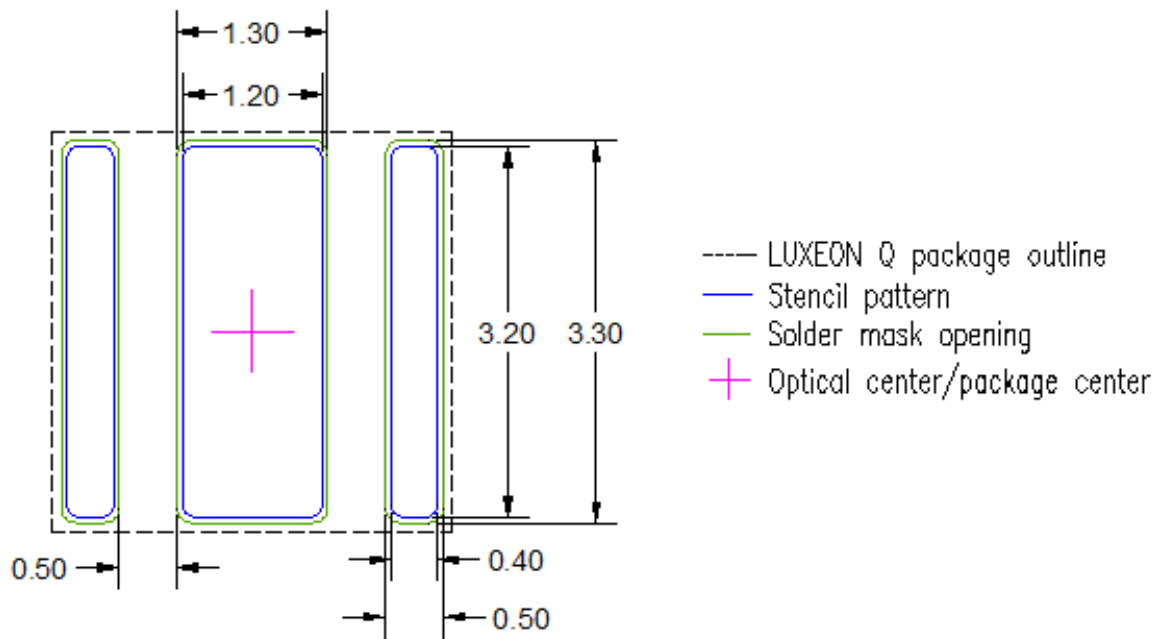

Figure 3. Solder pad layout.

Note for Figure 3:

- The photograph shows the recommended LUXEON Q layout on Printed Circuit Board (PCB).
- For more information on assembly and layout, please refer to Application Brief 118 (ABI 118).
- The .dwg files are available at www.philipslumileds.com and www.philipslumileds.cn.com.

Relative Spectral Distribution vs. Wavelength Characteristics

Relative Spectra at Test Current, Junction Temperature = 85°C

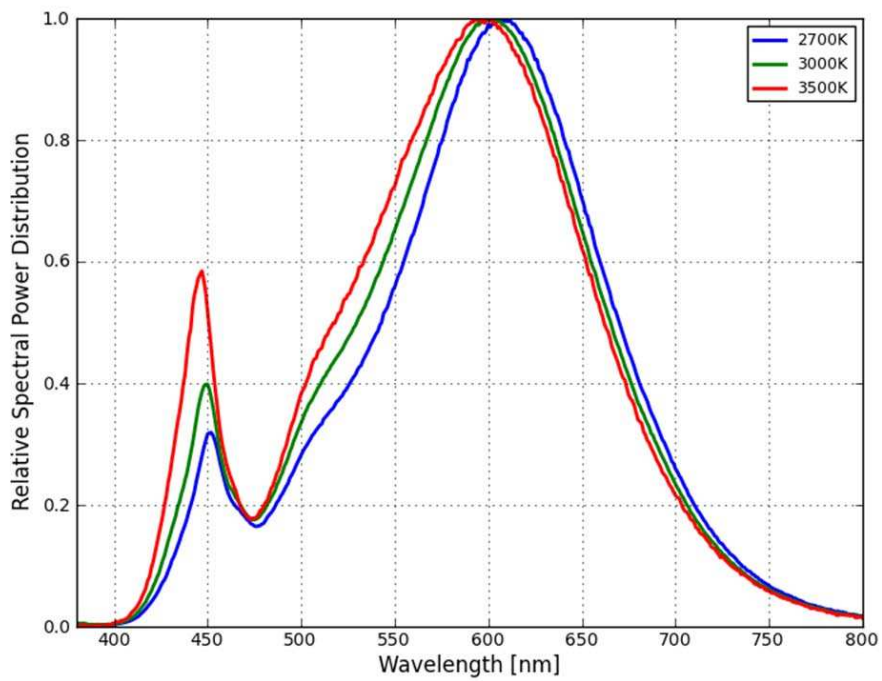

Figure 4. Color Spectrum of LIQ0-xx8000000zzz0.

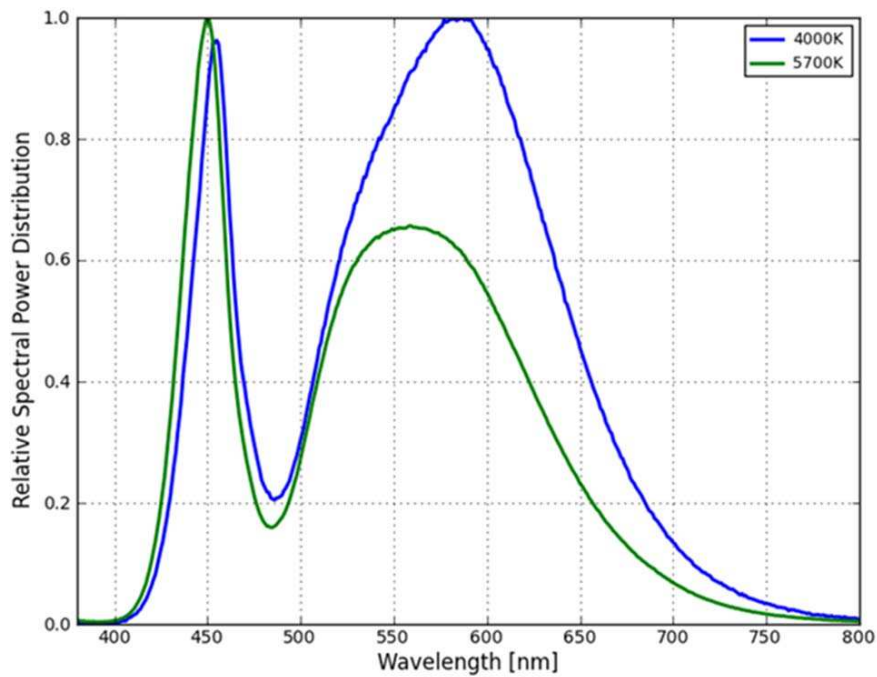

Figure 5. Color Spectrum of LIQ0-xx7000000zzz0.

Typical Light Output Characteristics

Relative Light Output vs. Junction Temperature, Test Current = 350 m

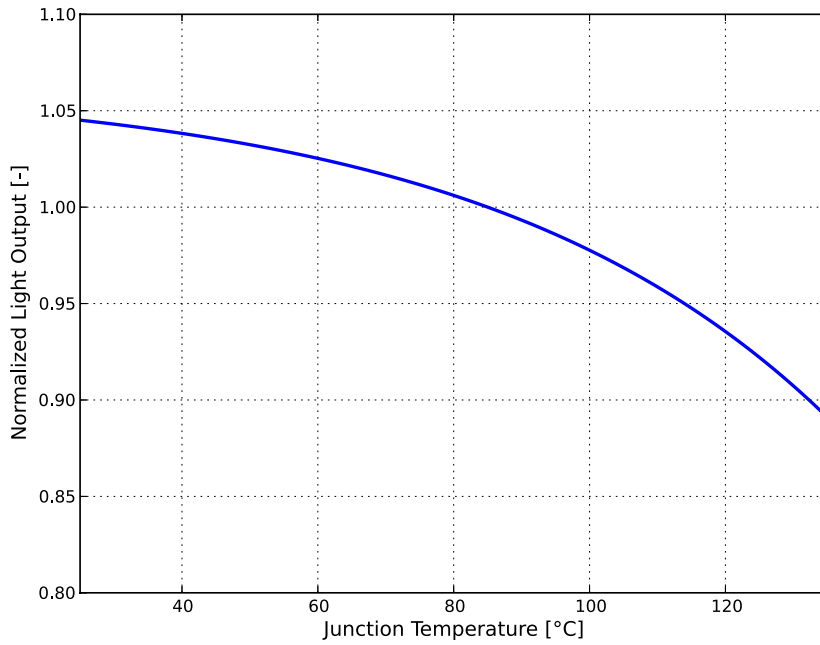

Figure 6. Relative light output vs. junction temperature, LIQ0-xyy00000zzz0.

Relative Light Output vs. Forward Current, Junction Temperature = 85°C

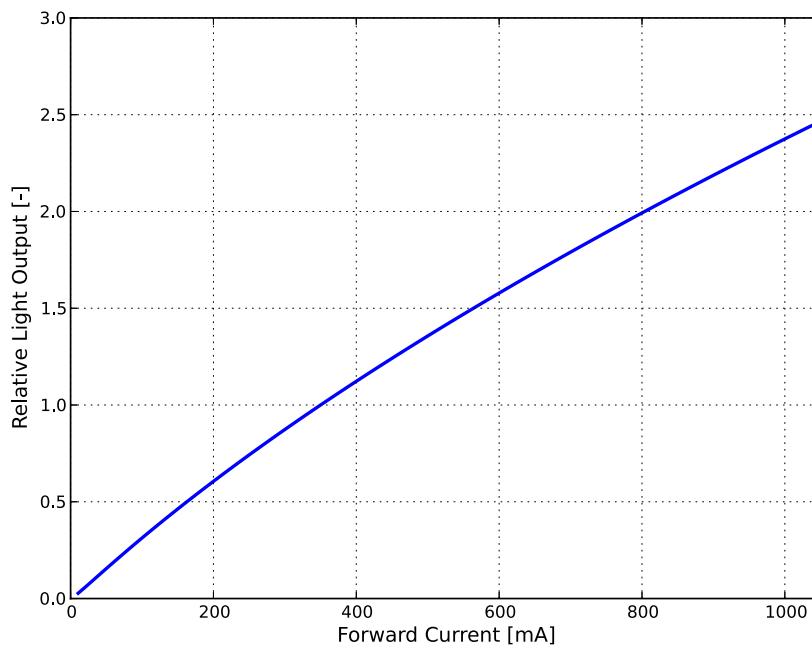

Figure 7. Typical relative luminous flux vs. forward current, LIQ0-xyy00000zzz0.

Typical Forward Current Characteristics

Forward Current vs. Forward Voltage
Junction Temperature = 85°C

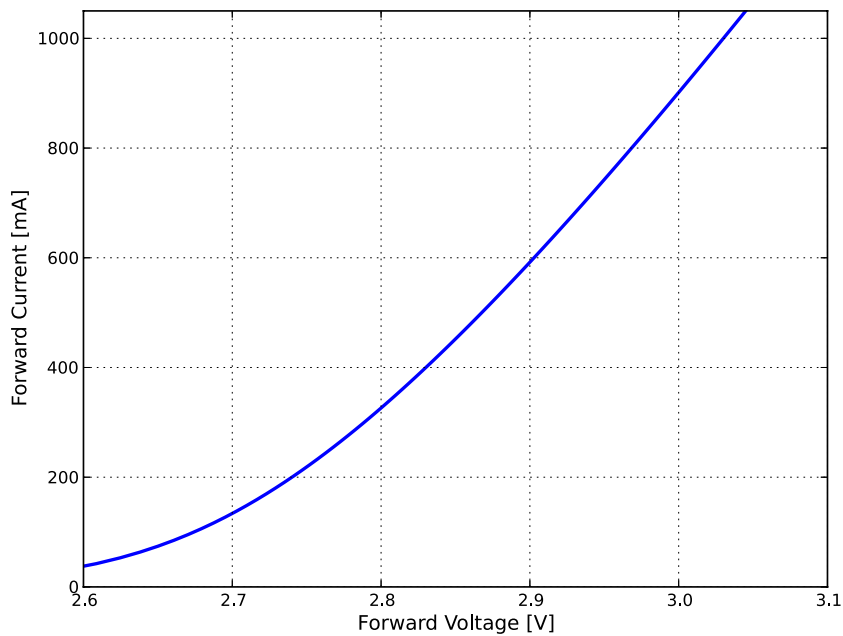

Figure 8. Typical forward current vs. forward volatage, LIQ0-xyy00000zzz0.

Typical Radiation Patterns

Typical Spatial Radiation Pattern

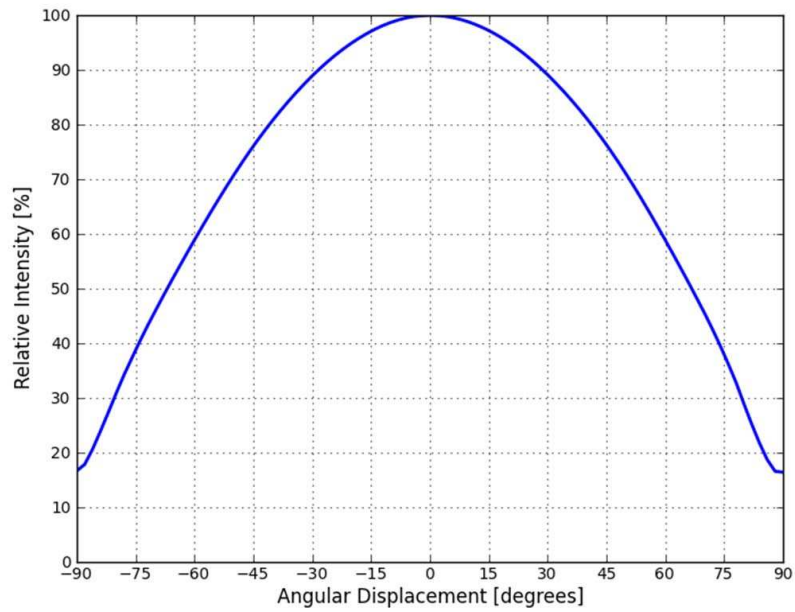

Figure 9. Typical representative spatial radiation pattern for LIQ0-xyy00000zzz0.

Typical Polar Radiation Pattern

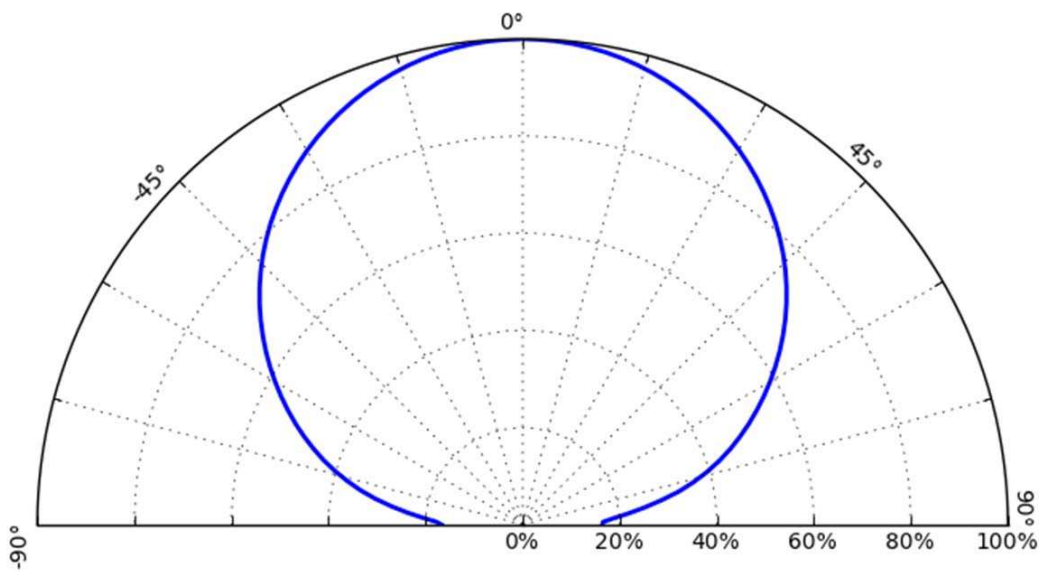

Figure 10. Typical representative polar radiation pattern for LIQ0-xyy00000zzz0.

Emitter Pocket Tape Packaging

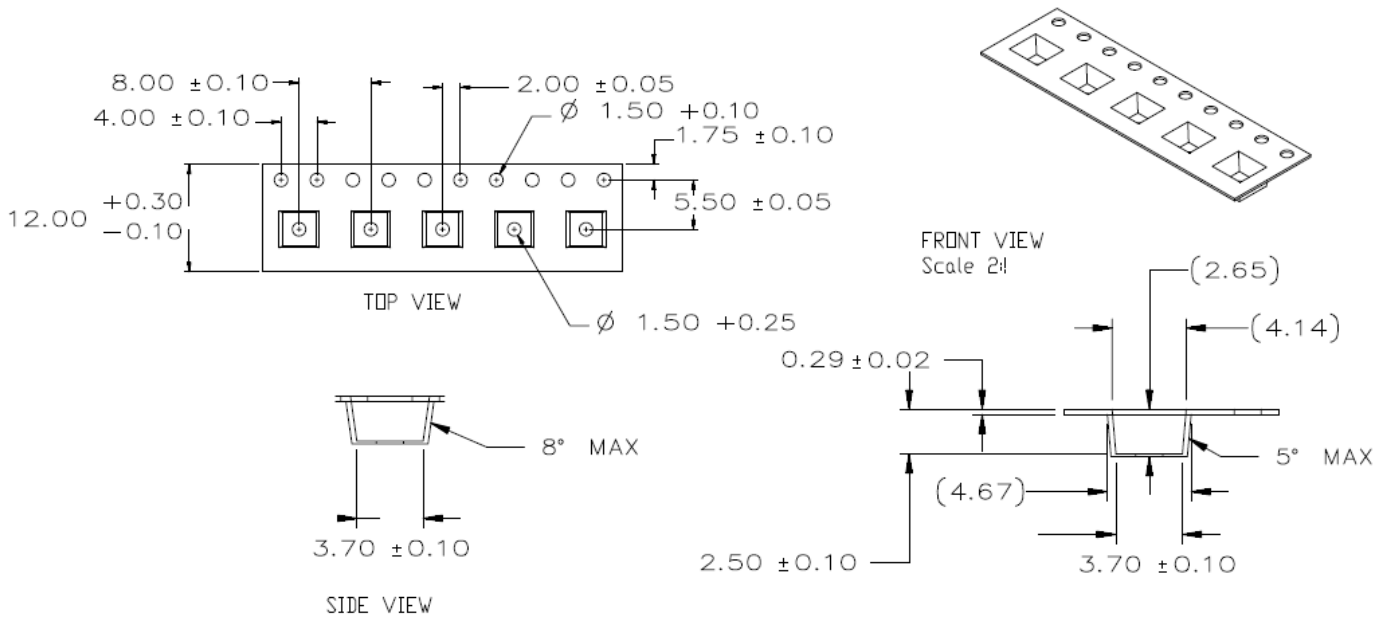
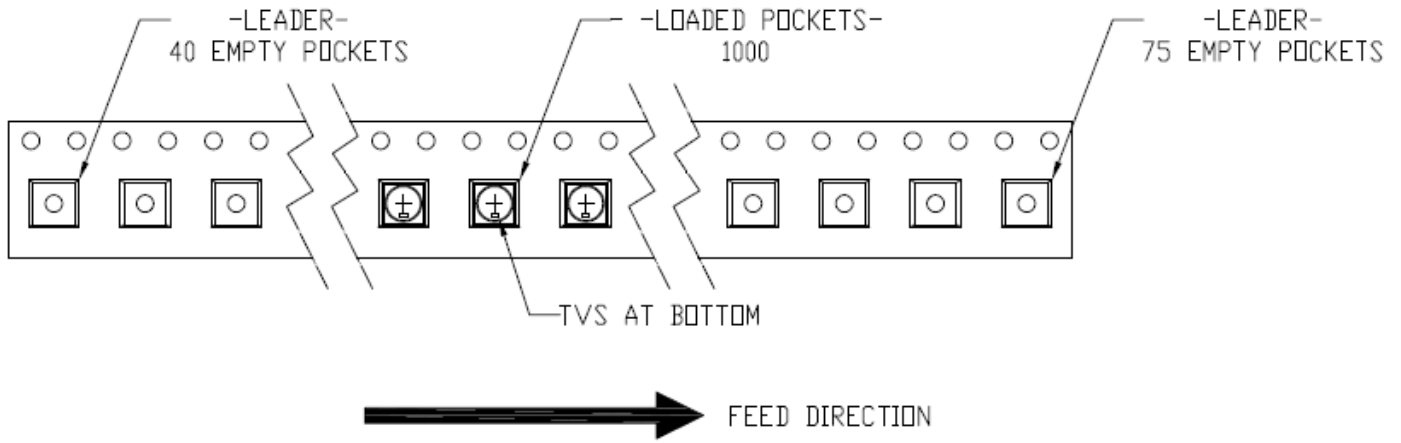

Figure 11. Emitter pocket tape packaging.

Emitter Reel Packaging

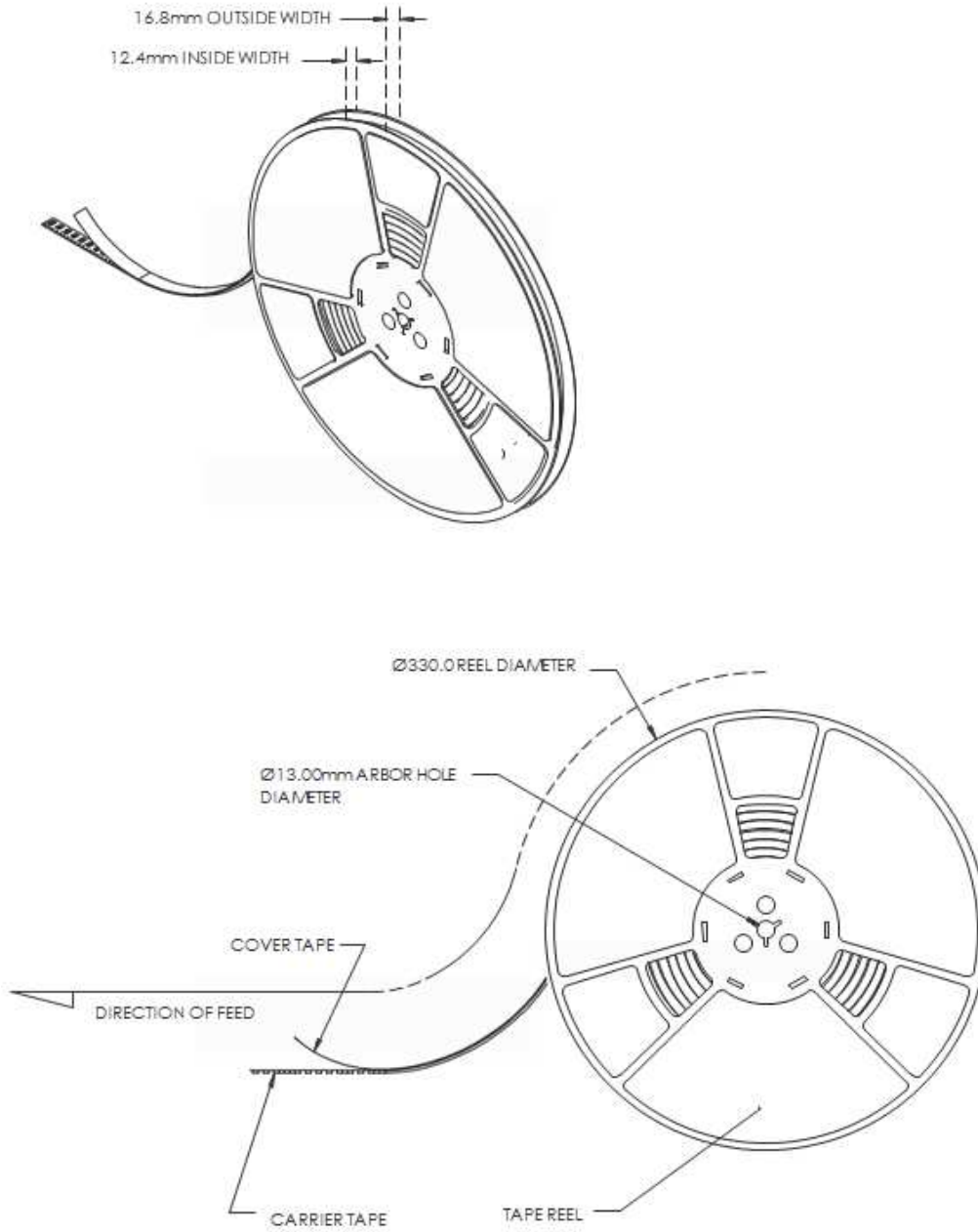

Figure 12. Emitter reel packaging.

Product Binning and Labeling

Purpose of Product Binning

In the manufacturing of semiconductor products, there are variations in performance around the average values given in the technical data sheets. For this reason, Philips Lumileds bins the LED components for luminous flux and forward voltage (V_f). Color is offered in a single 3-step or 5-step MacAdam ellipse color space centered on the ANSI CCT color bins. For additional information please review the MacAdam ellipse technical definition section.

Decoding Product Bin Labeling

LUXEON Q emitters are labeled using a four digit alphanumeric code (CAT code) depicting the bin values for emitters packaged on a single reel. All emitters packaged within a reel are of the same 3-variable bin combination.

Reels of LUXEON Q emitters are labeled with a four digit alphanumeric CAT code following the format below:

ABCD

A = Flux/Radiometric power bin (L, M, etc.)

B, C = Color bin (5A, 5B, 5C, 5D etc.)

D = V_f bin (R, S)

Luminous Flux and Forward Voltage Bins

Table 7 lists the standard photometric luminous flux bins for LUXEON Q emitters (tested and binned at 350 mA and $T_j = 85^\circ\text{C}$). Although several bins are outlined, product availability in a particular bin varies by production run and by product performance. Not all bins are available in all colors.

Table 7. Flux Bins

Bin Code	Minimum Photometric Flux (lm)	Maximum Photometric Flux (lm)
8	80	90
9	90	100
A	100	110
B	110	120
C	120	130
D	130	140
E	140	150
F	150	160
G	160	170

Table 8 lists minimum and maximum V_f bin values per emitter. Although several bins are outlined, product availability in a particular bin varies by production run and by product performance.

Table 8. V_f Bins

Bin Code	Minimum Forward Voltage (V)	Maximum Forward Voltage (V)
R	2.75	3.00
S	3.00	3.25

LUXEON Q 3-step and 5-step MacAdam Ellipse Color Definition

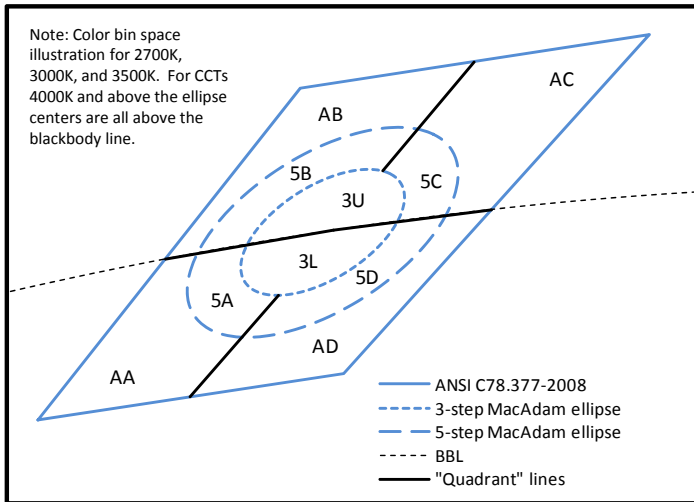

Color Space Definition for Above and Below Blackbody

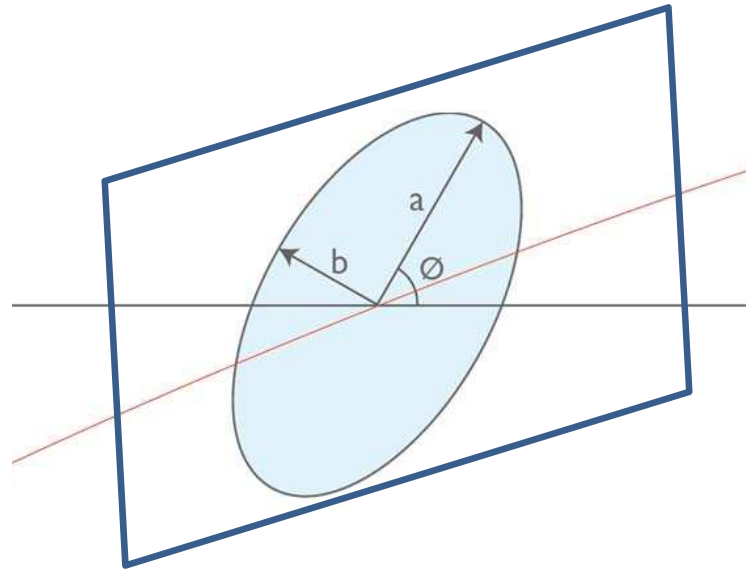

Parameter Definition of MacAdam Ellipse

Table 9. LUXEON Q Product Characteristics for 3-step MacAdam Ellipse

Nominal ANSI CCT	Color Space	Center Point (cx, cy)	Major Axis, a	Minor Axis, b	Ellipse Rotation Angle
2700K	Single 3-step MacAdam ellipse	(0.4578, 0.4101)	0.00810	0.00420	53.7
3000K	Single 3-step MacAdam ellipse	(0.4338, 0.4030)	0.00834	0.00408	53.2
3500K	Single 3-step MacAdam ellipse	(0.4073, 0.3917)	0.00927	0.00414	54.0
4000K	Single 3-step MacAdam ellipse	(0.3818, 0.3797)	0.00939	0.00402	53.7
5700K	Single 3-step MacAdam ellipse	(0.3287, 0.3417)	0.00745	0.00319	59.1

Min 80 CRI 3-step color bins available above (3U) and below (3L) the blackbody line. Min 70 CRI 3-step is not divided into bins above and below the blackbody line.

Table 10. LUXEON Q Product Characteristics for 5-step MacAdam Ellipse

Nominal ANSI CCT	Color Space	Center Point (cx, cy)	Major Axis, a	Minor Axis, b	Ellipse Rotation Angle
2700K	Single 5-step MacAdam ellipse	(0.4578, 0.4101)	0.01350	0.00700	53.7
3000K	Single 5-step MacAdam ellipse	(0.4338, 0.4030)	0.01390	0.00680	53.2
3500K	Single 5-step MacAdam ellipse	(0.4073, 0.3917)	0.01545	0.00690	54.0
4000K	Single 5-step MacAdam ellipse	(0.3818, 0.3797)	0.01565	0.00670	53.7
5700K	Single 5-step MacAdam ellipse	(0.3287, 0.3417)	0.01234	0.00533	59.1

Min 70 and min 80 CRI 5-step is divided into quadrants (5A, 5B, 5C, and 5D).

Notes for Tables 9 & 10:

I. Philips Lumileds maintains a tester tolerance of ± 0.005 on x, y color coordinates.

Who We Are

Philips Lumileds focuses on one goal: Creating the world's highest performing LEDs. The company pioneered the use of solid-state lighting in breakthrough products such as the first LED backlit TV, the first LED flash in camera phones, and the first LED daytime running lights for cars. Today we offer the most comprehensive portfolio of high quality LEDs and uncompromising service.

Philips Lumileds brings LED's qualities of energy efficiency, digital control and long life to spotlights, downlights, high bay and low bay lighting, indoor area lighting, architectural and specialty lighting as well as retrofit lamps. Our products are engineered for optimal light quality and unprecedented efficacy at the lowest overall cost. By offering LEDs in chip, packaged and module form, we deliver supply chain flexibility to the inventors of next generation illumination.

Philips Lumileds understands that solid state lighting is not just about energy efficiency. It is about elegant design. Reinventing form. Engineering new materials. Pioneering markets and simplifying the supply chain. It's about a shared vision. Learn more about our comprehensive portfolio of LEDs at www.philipslumileds.com.

Philips Lumileds Lighting Company shall not be liable for any kind of loss of data or any other damages, direct, indirect or consequential, resulting from the use of the provided information and data. Although Philips Lumileds Lighting Company has attempted to provide the most accurate information and data, the materials and services information and data are provided "as is" and Philips Lumileds Lighting Company neither warranties, nor guarantees the contents and correctness of the provided information and data. Philips Lumileds Lighting Company reserves the right to make changes without notice. You as user agree to this disclaimer and user agreement with the download or use of the provided materials, information and data.



©2014 Philips Lumileds Lighting Company. All rights reserved.
LUXEON is a registered trademark of the Philips Lumileds Lighting Company in the United States and other countries.

www.philipslumileds.com
www.philipslumileds.cn.com

LUXEON Q Datasheet DS118 20140109