

LUXEON Z

LUXEON Z ES

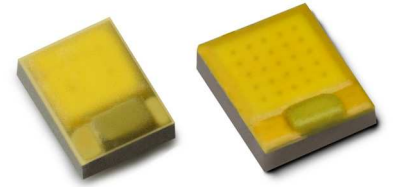

Breakthrough luminance, design flexibility
and optical control for Illumination solutions



Introduction

Philips Lumileds technology enables the new LUXEON® Z and LUXEON Z ES LEDs.

The LUXEON Z is a family of micro sized Illumination grade emitters that is the first ever 1-step MacAdam Ellipse warm white LED that enables never before seen color consistency, luminance, flux density and design flexibility for next generation lighting solutions. LUXEON Z family is undomed, a feature that provides un-matched optical flexibility for precise beam angle control. Tested and binned at application conditions ($T_j = 85^\circ\text{C}$), the LUXEON Z and Z ES emitters are an ideal choice for indoor and outdoor light sources requiring superior beam angles, higher efficacy and lower costs.

Features

- Micro sized: LUXEON Z, 1.3 x 1.7 mm and LUXEON Z ES, 1.6 x 2.0 mm
- Undomed device architecture
- Hot tested at $T_j = 85^\circ\text{C}$
- Max drive current: LUXEON Z ES 1.2A, LUXEON Z 1A
- *Freedom from Binning*
- 1, 3, 5 step SDCM MacAdam ellipse options
- Lowest thermal resistance 3°C/W

Benefits

- Highest luminance to deliver punch
- Ultimate design flexibility from micro form factor
- Precise optical control from an undomed architecture
- Enables small customizable and scalable light engines
- Leading system level lm/\$ proposition

Key Applications

- Architectural
- Downlight
- Indoor area
- Lamps
 - MR16, PAR, GU10 and Candles
- Outdoor area
 - High-flux street light modules
- Specialty lighting
- Spotlight

Table of Contents

General Information	2
Product Nomenclature	2
Average Lumen Maintenance Characteristics	2
Environmental Compliance	2
Product Selection	3
Optical Characteristics	4
Electrical Characteristics	4
Absolute Maximum Ratings	5
JEDEC Moisture Sensitivity	5
Mechanical Dimensions of LUXEON Z ES	6
Mechanical Dimensions of LUXEON Z	7
Solder Pad Design	8
Relative Spectral Distribution	9
Light Output Characteristics	10
Typical Spatial Radiation Pattern	14
Emitter Pocket Tape Packaging for LUXEON Z ES	16
Emitter Reel Packaging for LUXEON Z ES	16
Emitter Pocket Tape Packaging for LUXEON Z	17
Emitter Reel Packaging for LUXEON Z	18
Product Binning and Labeling	19
Luminous Flux and Forward Voltage Bins	20
LUXEON Z and LUXEON Z ES: 1-step, 3-step (above and below blackbody) and 5-step MacAdam Ellipse Color Definition	21

General Information

Product Nomenclature

LUXEON Z and Z ES emitters are specified and binned under “hot” conditions comparable to those found in “real-world” lighting products. The test conditions for LUXEON Z ES and LUXEON Z are 700 mA DC and 500 mA DC respectively with junction temperature at 85°C

The part number designation is explained as follows:

L X Z n - a b c d - y

Where:

- n — 1 for LUXEON Z and 2 for LUXEON Z ES
- a, b — designates nominal ANSI CCT (27 for 2700K, 30 for 3000K, RB for Royal Blue)
- c, d — designates minimum CRI performance (7 for 70 CRI, 8 for 80 CRI, 9 for 90 CRI)
- y — 1 designates 1 SDCM*, 3 designates 3 SDCM and 5 designates 5 SDCM (only for 80 and 90 CRI versions. 70 CRI parts or lower will not have a SDCM designation and all parts are binned within a 5 step SDCM).

Therefore, 3 SDCM 2700K/80 CRI LUXEON Z ES will have the following part number:

L X Z 2 - 2 7 8 0 - 3

Therefore, 4000K/70 CRI LUXEON Z ES will have the following part number:

L X Z 2 - 4 0 7 0

Therefore, 5 SDCM 3000K/80 CRI LUXEON Z will have the following part number:

L X Z 1 - 3 0 8 0 - 5

Average Lumen Maintenance Characteristics

LUXEON Z products are tested in compliance with LM-80. Please visit www.philipslumileds.com/support/documentation/lumen-maintenance or contact your local Philips Lumileds Technical Solutions Manager for TM-21 extrapolations or other support.

Environmental Compliance

Philips Lumileds is committed to providing environmentally friendly products to the solid-state lighting market. LUXEON Z and LUXEON Z ES products are compliant to the European Union directives on the restriction of hazardous substances in electronic equipment, namely the RoHS and REACH directives. Philips Lumileds will not intentionally add the following restricted material to the LUXEON Z and LUXEON Z ES: lead, mercury, cadmium, hexavalent chromium, polybrominated biphenyls (PBB) or polybrominated diphenyl ethers (PBDE).

* 1 SDCM is available on special request. Please contact your Sales representative.

Product Selection

Product Selection Guide for LUXEON Z ES Emitters Junction Temperature = 85°C

Table 1. LUXEON Z ES

Part Number	Nominal CCT	Min CRI	700 mA				1A			350 mA		
			Min. Flux (lm)	Typical Flux (lm)	Typical Vf (V)	Typical Efficacy (lm/W)	Typical Flux (lm)	Typical Vf (V)	Typical Efficacy (lm/W)	Typical Flux (lm)	Typical Vf (V)	Typical Efficacy (lm/W)
LXZ2-2780-y	2700K	80	150	175	2.80	89	198	2.86	81	102	2.72	107
LXZ2-2790-y	2700K	90	110	135	2.80	69	178	2.86	62	79	2.72	83
LXZ2-3080-y	3000K	80	160	180	2.80	92	238	2.86	83	105	2.72	111
LXZ2-3090-y	3000K	90	120	145	2.80	74	191	2.86	67	85	2.72	89
LXZ2-3580-y	3500K	80	170	190	2.80	97	251	2.86	88	111	2.72	117
LXZ2-4080-y	4000K	80	180	195	2.80	99	257	2.86	90	114	2.72	120
LXZ2-4070	4000K	70	190	210	2.80	107	277	2.86	97	123	2.72	129
LXZ2-5070	5000K	70	200	215	2.80	110	284	2.86	99	126	2.72	132
LXZ2-5770	5700K	70	200	215	2.80	110	284	2.86	99	126	2.72	132

Notes for Table 1:

- All LUXEON Z ES emitters are tested and binned at 700 mA/85°C.
- Philips Lumileds maintains a tolerance of $\pm 6.5\%$ on luminous flux and ± 2 on CRI measurements.
- In the part number the -y is the designation for the color requirement. On 80 and 90 CRI versions -1 designates 1 SDCM, -3 designates 3 SDCM, -5 designates 5 SDCM. 70 CRI parts or lower will not have a SDCM designation and all parts are binned within a 5 step SDCM.

Product Selection for LUXEON Z Emitters Junction Temperature = 85°C

Table 2. LUXEON Z

Part Number	Nominal CCT	Min CRI	500 mA				700 mA			1A		
			Min. Flux (lm)	Typical Flux (lm)	Typical Vf (V)	Typical Efficacy (lm/W)	Typical Flux (lm)	Typical Vf (V)	Typical Efficacy (lm/W)	Typical Flux (lm)	Typical Vf (V)	Typical Efficacy (lm/W)
LXZ1-2780-y	2700K	80	100	115	2.80	82	147	2.85	74	191	2.89	66
LXZ1-3080-y	3000K	80	110	124	2.80	89	159	2.85	80	206	2.89	71
LXZ1-3580-y	3500K	80	110	124	2.80	89	159	2.85	80	206	2.89	71
LXZ1-4080-y	4000K	80	120	130	2.80	93	166	2.85	83	216	2.89	75
LXZ1-4070	4000K	70	120	134	2.80	96	172	2.85	86	223	2.89	77
LXZ1-5070	5000K	70	130	148	2.80	106	189	2.85	95	246	2.89	85
LXZ1-5770	5700K	70	140	152	2.80	109	195	2.85	98	253	2.89	88
LXZ1-6565	6500K	65	140	154	2.80	110	197	2.85	99	256	2.89	89

Notes for Table 2:

- All LUXEON Z emitters above are tested and binned at 500 mA/85°C.
- Philips Lumileds maintains a tolerance of $\pm 6.5\%$ on luminous flux and ± 2 on CRI measurements.
- In the part number the -y is the designation for the color requirement. On 80 CRI versions -3 designates 3 SDCM and -5 designates 5 SDCM. 70 CRI parts or lower will not have a SDCM designation and all parts are binned within a 5 step SDCM.

Optical Characteristics

LUXEON Z ES at Test Current 700 mA, Junction Temperature 85°C & LUXEON Z at Test Current 500 mA, Junction Temperature 85°C

Table 3.

Nominal ANSI CCT	Color Temperature CCT Typical	Typical Total Included Angle ¹ (degrees) $\theta_{0.90V}$	Typical Viewing Angle ² (degrees) $2\theta_{1/2}$
2700K	2725K	160	120
3000K	3045K	160	120
3500K	3465K	160	120
4000K	3985K	160	120
5000K	5028K	160	120
5700K	5665K	160	120
6500K	6250K	160	120

Notes for Table 3:

1. Total angle at which 90% of total luminous flux is captured.
2. Viewing angle is the off axis angle from lamp centerline where the luminous intensity is 1/2 of the peak value.

Electrical Characteristics

LUXEON Z ES at Test Current 700 mA, Junction Temperature 85°C & LUXEON Z at Test Current 500 mA, Junction Temperature 85°C

Table 4.

Nominal ANSI CCT	Forward Voltage Vf, ¹ (V)		Typical Temperature Coefficient of Forward Voltage ² (mV/°C) $\Delta V_F / \Delta T_J$	LUXEON Z ES Typical Thermal Resistance Junction to Thermal Pad (°C/W) $R\theta_{J-C}$	LUXEON Z Typical Thermal Resistance Junction to Electrical Pads (°C/W) $R\theta_{J-C}$
	Min.	Max.			
2700K	2.5	3.25	-1.6	3	6
3000K	2.5	3.25	-1.6	3	6
3500K	2.5	3.25	-1.6	3	6
4000K	2.5	3.25	-1.6	3	6
5000K	2.5	3.25	-1.6	3	6
5700K	2.5	3.25	-1.6	3	6
6500K	2.5	3.25	-1.6	3	6

Notes for Table 4:

1. Philips Lumileds maintains a tolerance of ±0.06V on forward voltage measurements.
2. Measured between $T_J = 25^\circ\text{C}$ and $T_J = 110^\circ\text{C}$ at $I_f = 700\text{ mA}$ for LUXEON Z ES and $I_f = 500\text{ mA}$ for LUXEON Z.

Absolute Maximum Ratings

Table 5.

Parameter	LUXEON Z ES	LUXEON Z
DC Forward Current (mA) ^{1,2}	1200	1000
Peak Pulsed Forward Current (mA) ^{1,3}	1350	1200
ESD Sensitivity	< 8000V Human Body Model (HBM) Class 3A JEDEC JS-001-2012	< 8000V Human Body Model (HBM) Class 3A JEDEC JS-001-2012
LED Junction Temperature ¹	135°C	135°C
Operating Case Temperature at 700 mA	-40°C - 135°C	-40°C - 135°C
Storage Temperature	-40°C - 135°C	-40°C - 135°C
Soldering Temperature	JEDEC 020c 260°C	JEDEC 020c 260°C
Allowable Reflow Cycles	3	3
Reverse Voltage (Vr) ^{5,6}	LUXEON Z LEDs are not designed to be driven in reverse bias	

Notes for Table 5:

- Proper current derating must be observed to maintain junction temperature below the maximum. For additional information on thermal measurement guidelines please refer to Application Briefs AB105 and AB120.
- Residual periodic variations due to power conversion from alternating current (AC) to direct current (DC), also called "ripple", with frequencies ≥ 100 Hz and amplitude ≤ 150 mA and 200 mA respectively are acceptable, assuming the average current throughout each cycle does not exceed 1200 mA and 1000 mA respectively.
- Pulsed operation with a peak drive current of 1350 mA and 1200 mA respectively are acceptable if the pulse on-time is ≤ 5 ms per cycle and the duty cycle is $\leq 50\%$.
- Transient reverse voltages and surge currents due to electrical switching or supply interruptions are acceptable if these events do not last for more than 10ms, the amplitude of the reverse voltage does not exceed 5V and the reverse current is less than 200 μ A.
- Maximum 5V reverse for up to 10s is an acceptable beginning of life, one time test condition.

JEDEC Moisture Sensitivity

Table 6.

Level	Floor Life		Soak Requirements Standard	
	Time	Conditions	Time	Conditions
I	unlimited	$\leq 30^\circ\text{C}$ / 85% RH	168h + 5 / - 0	85°C / 85% RH

Mechanical Dimensions of LUXEON Z ES

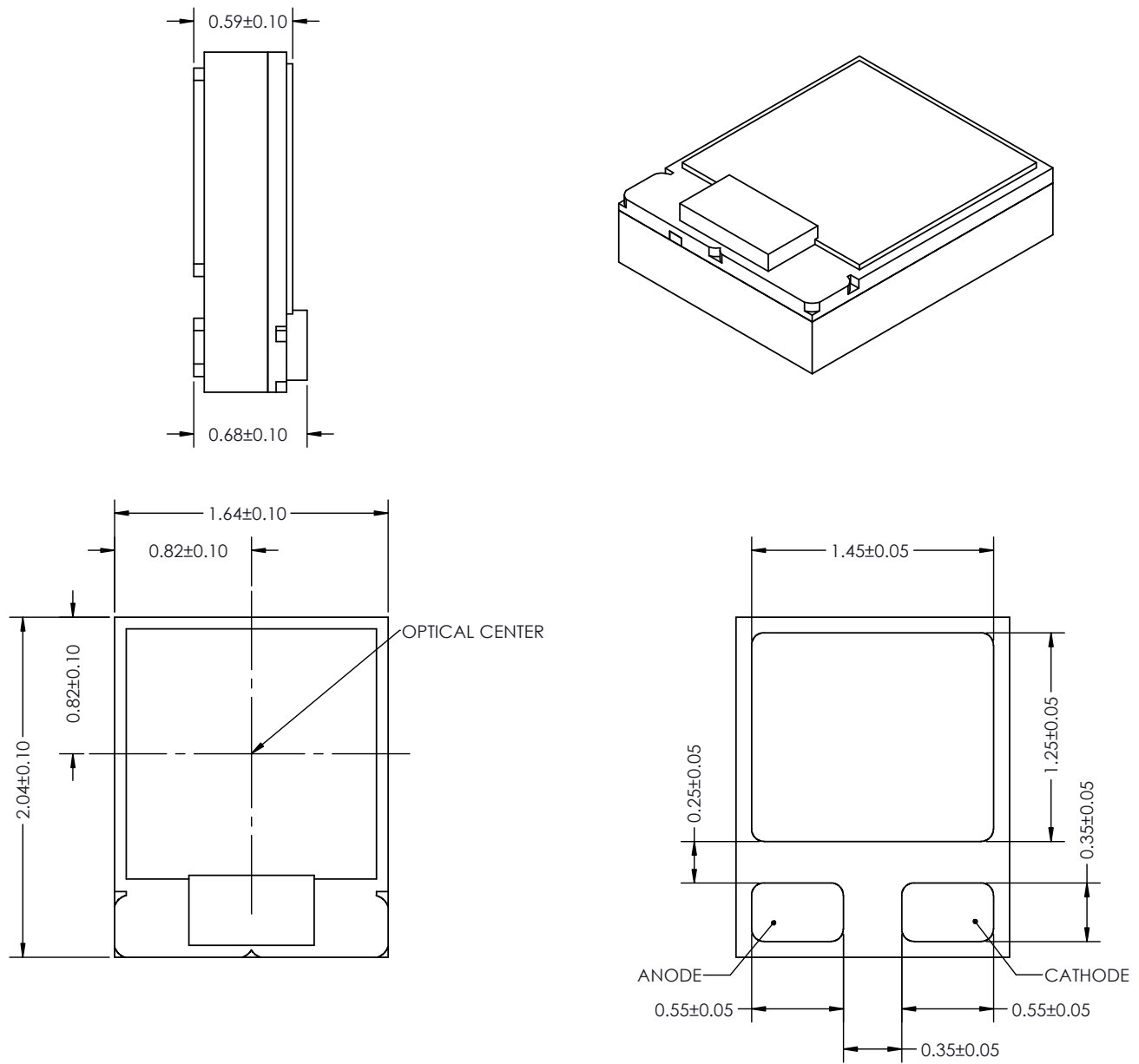

Figure 1. Package outline drawing for LUXEON Z ES.

Notes for Figure 1:

1. Do not handle the device by the top of package. Excessive force on the top of the package may damage the surface or the interior of the device.
2. Drawings not to scale.
3. All dimensions are in millimeters.
4. The thermal pad is electrically isolated from the anode and cathode contact pads.

Mechanical Dimensions of LUXEON Z

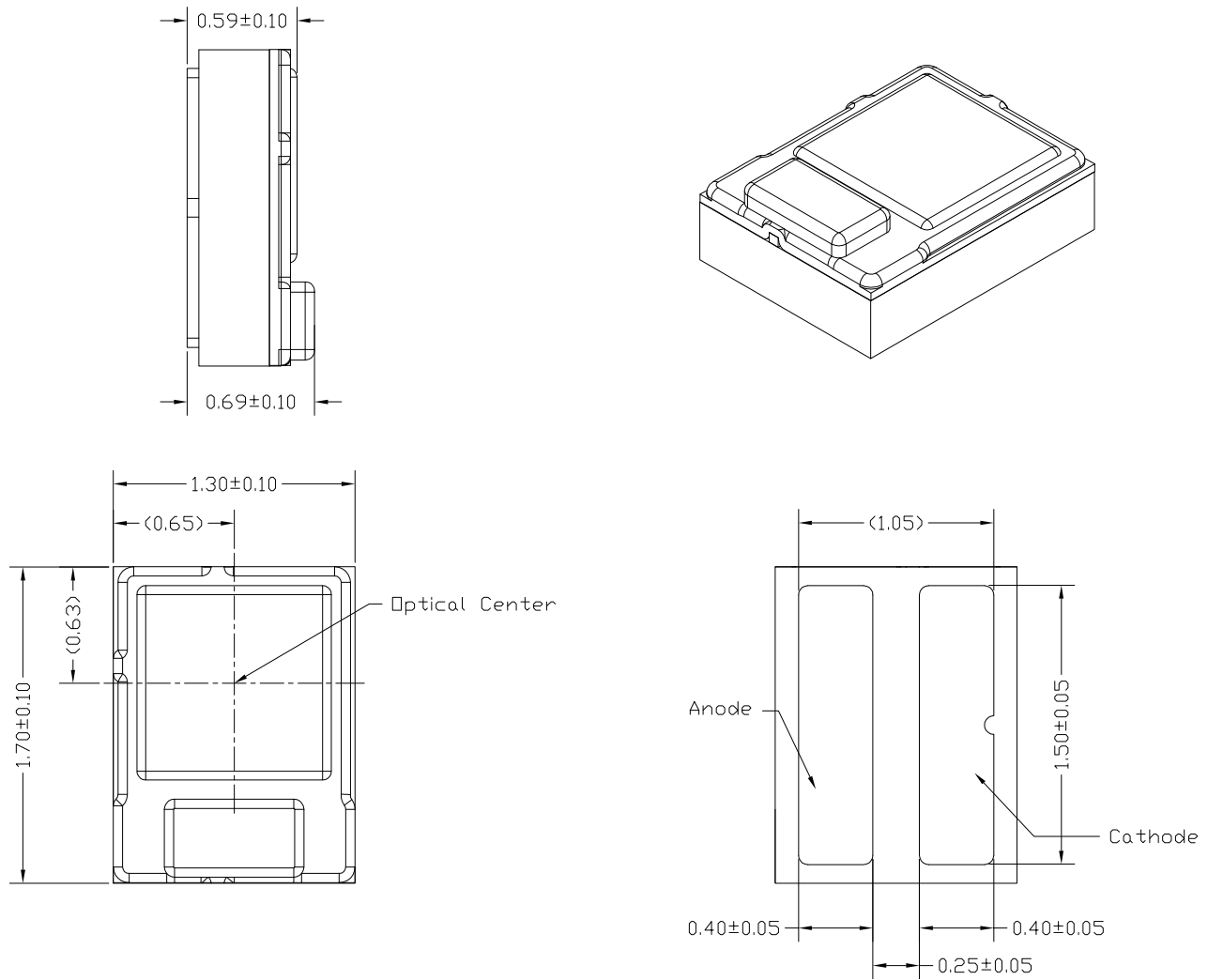

Figure 2. Package outline drawing for LUXEON Z.

Notes for Figure 2:

1. Do not handle the device by the top of package. Excessive force on the top of the package may damage the surface or the interior of the device.
2. Drawings not to scale.
3. All dimensions are in millimeters.
4. Both the anode and cathode contact pads are also the thermal pads.

Solder Pad Design

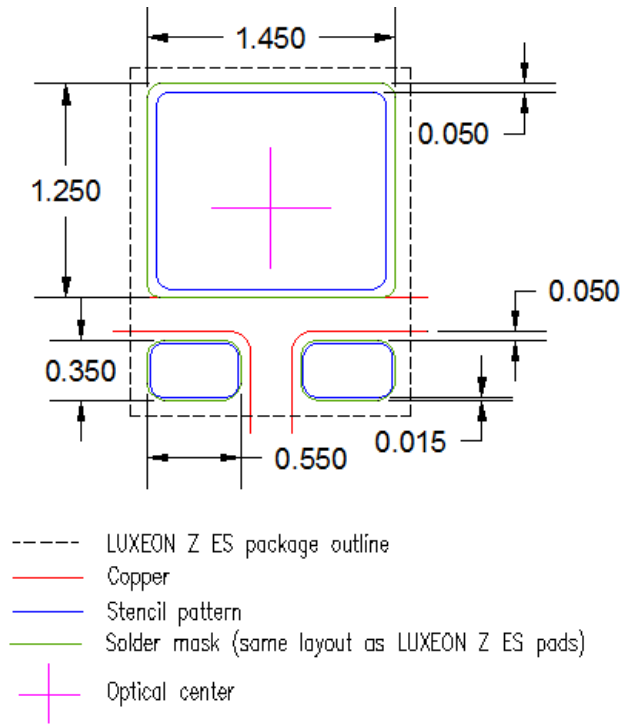

Figure 3. Recommended PCB footprint for LUXEON Z ES for high component count density based on solder mask defined pads. Dimensions in mm.

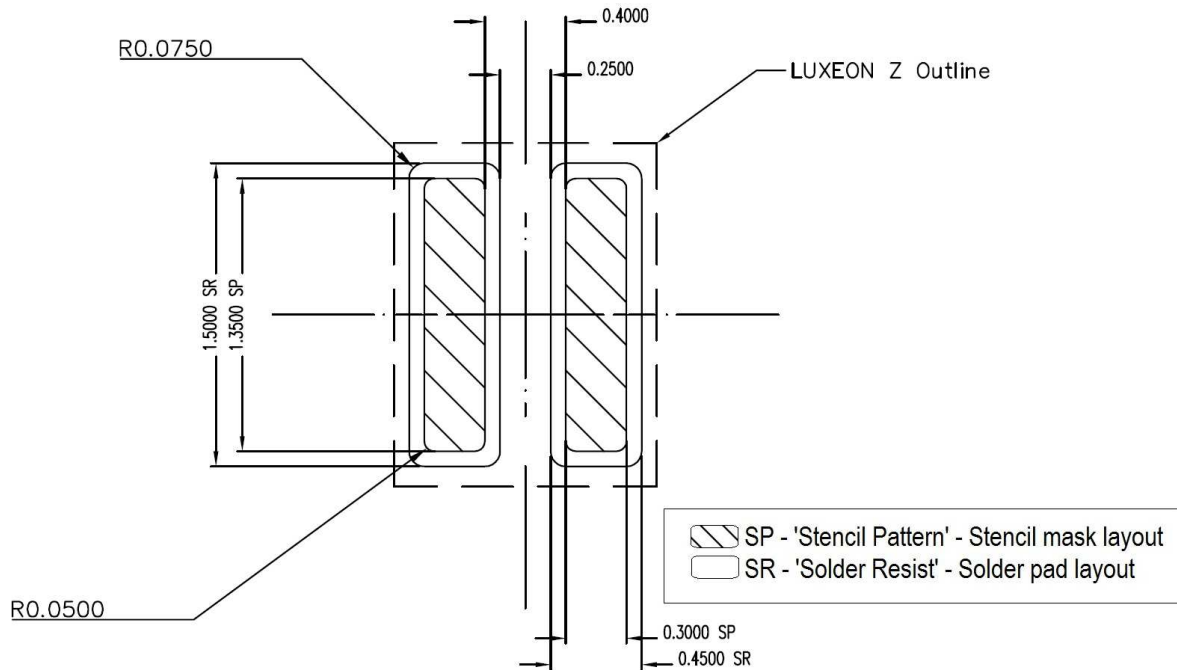

Figure 4. Solder pad layout for LUXEON Z.

Notes for Figures 3 and 4:

1. The drawing above shows the recommended solder pad layout on Printed Circuit Board (PCB).
2. Application Brief AB120 (LUXEON Z ES) and AB105 (LUXEON Z) provide the details of the PCB board layout design. In addition, the .dwg files are available at www.philipslumileds.com and www.philipslumileds.cn.com.

Relative Spectral Distribution

Relative Spectral Distribution vs. Wavelength Characteristics

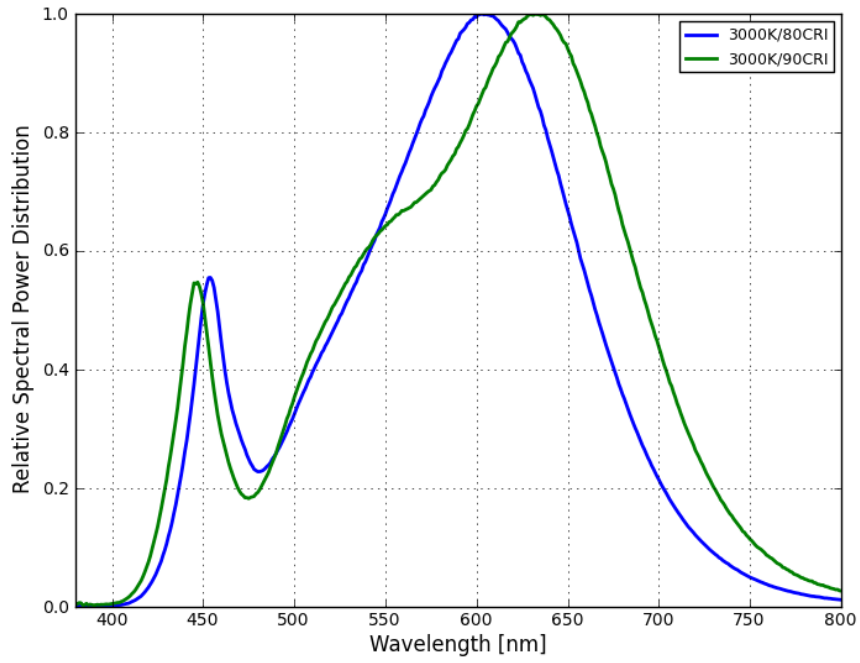

Figure 5.

Light Output Characteristics

Relative Light Output vs. Junction Temperature for LUXEON Z ES,
Test Current at 700 mA



Figure 6.

Relative Light Output vs. Forward Current for LUXEON Z ES,
Junction Temperature = 85°C

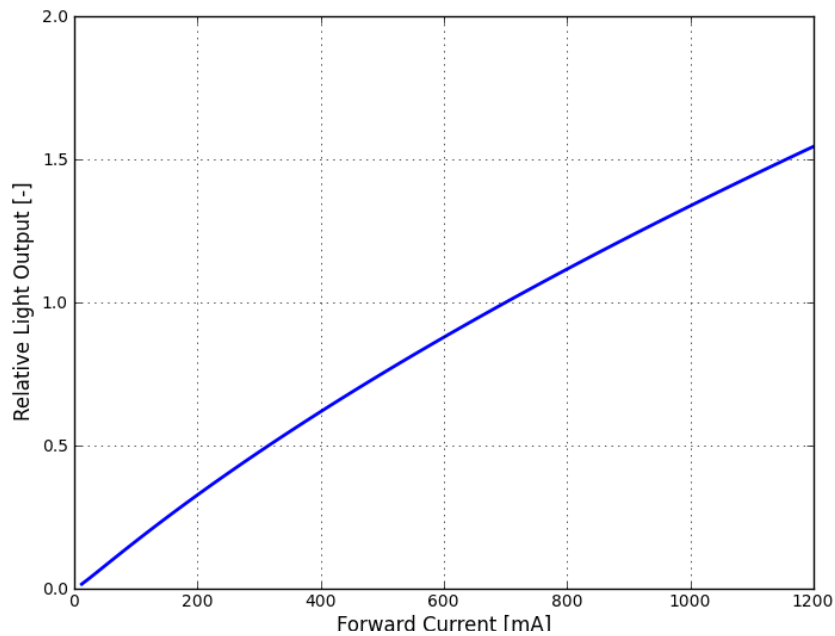

Figure 7.

Forward Current Characteristics for LUXEON Z ES,
Junction Temperature = 85°C

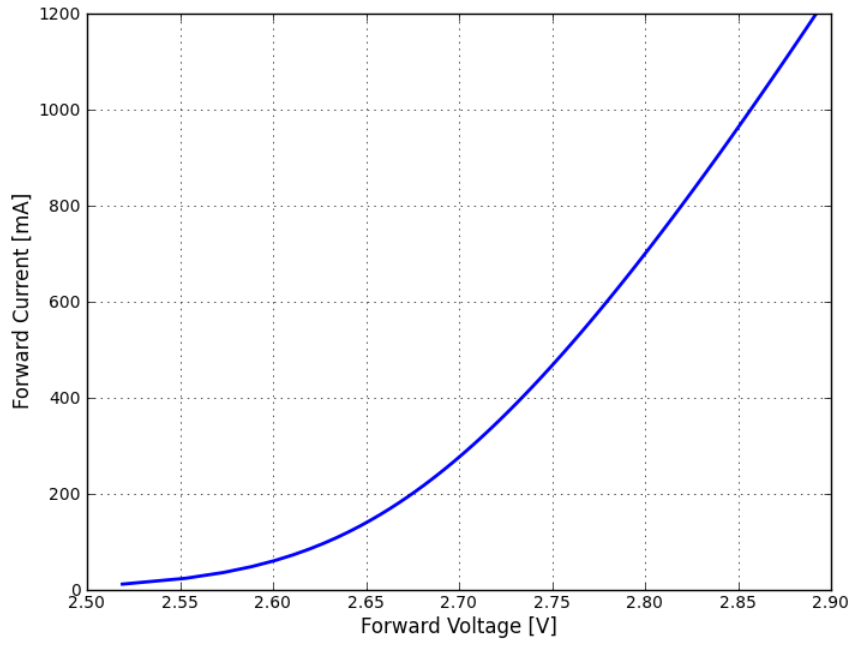

Figure 8.

Relative Light Output vs. Junction Temperature for LUXEON Z White, Test Current at 500 mA



Figure 9.

Relative Light Output vs. Forward Current for LUXEON Z White, Junction Temperature = 85°C

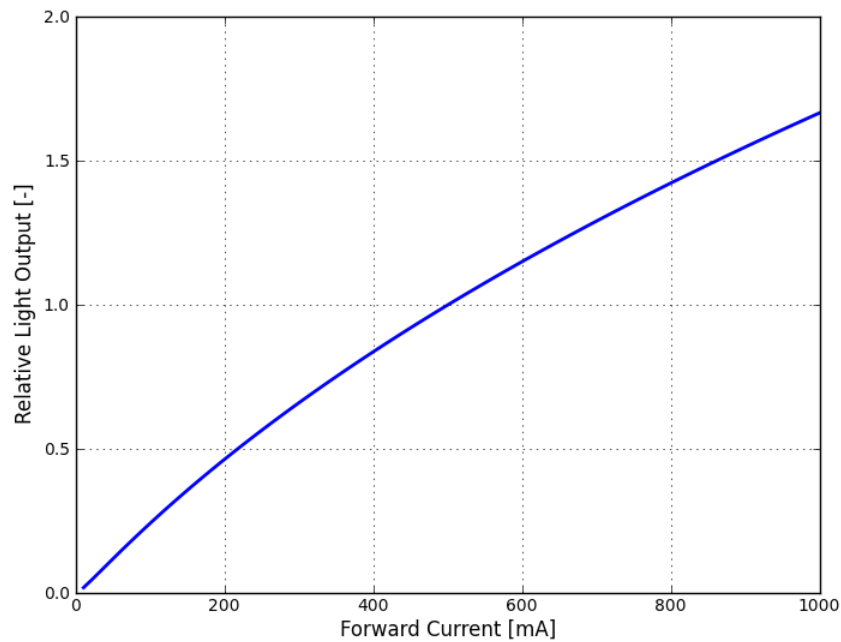

Figure 10.

Forward Current Characteristics for LUXEON Z White,
Junction Temperature = 85°C

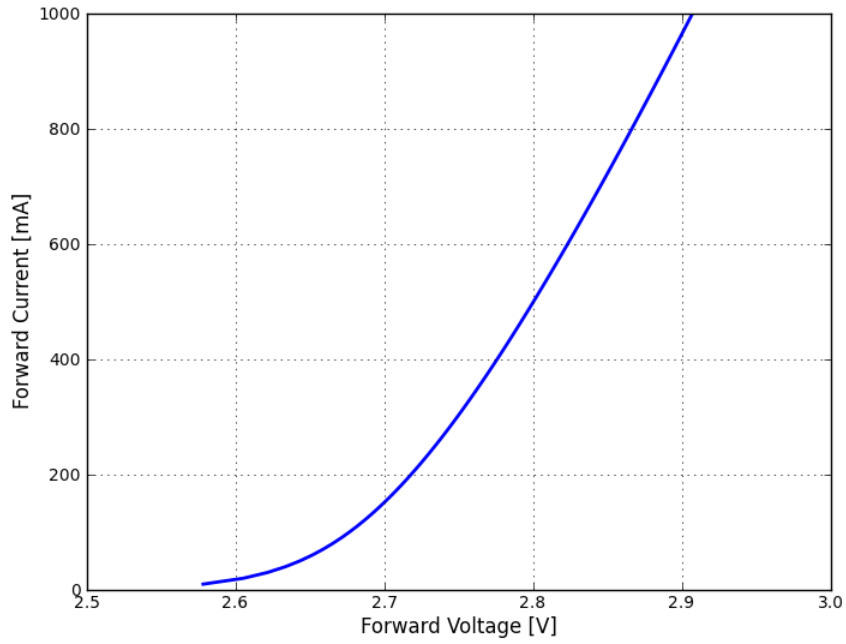

Figure 11.

Typical Spatial Radiation Pattern

LUXEON Z ES

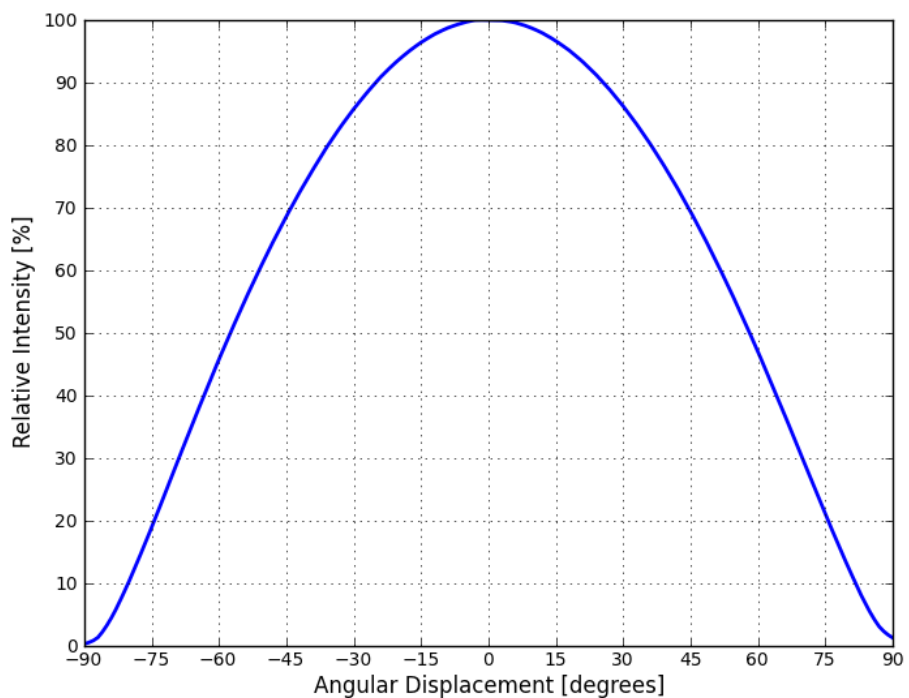

Figure 12.

LUXEON Z ES Typical Polar Radiation Pattern

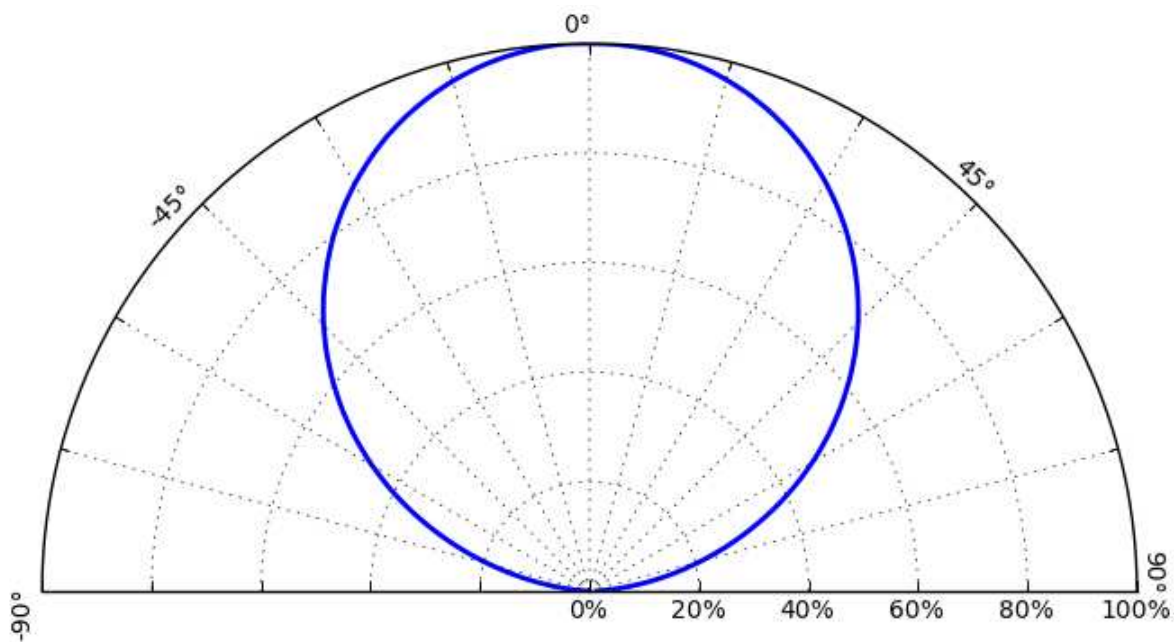

Figure 13.

Typical Spatial Radiation Pattern

LUXEON Z

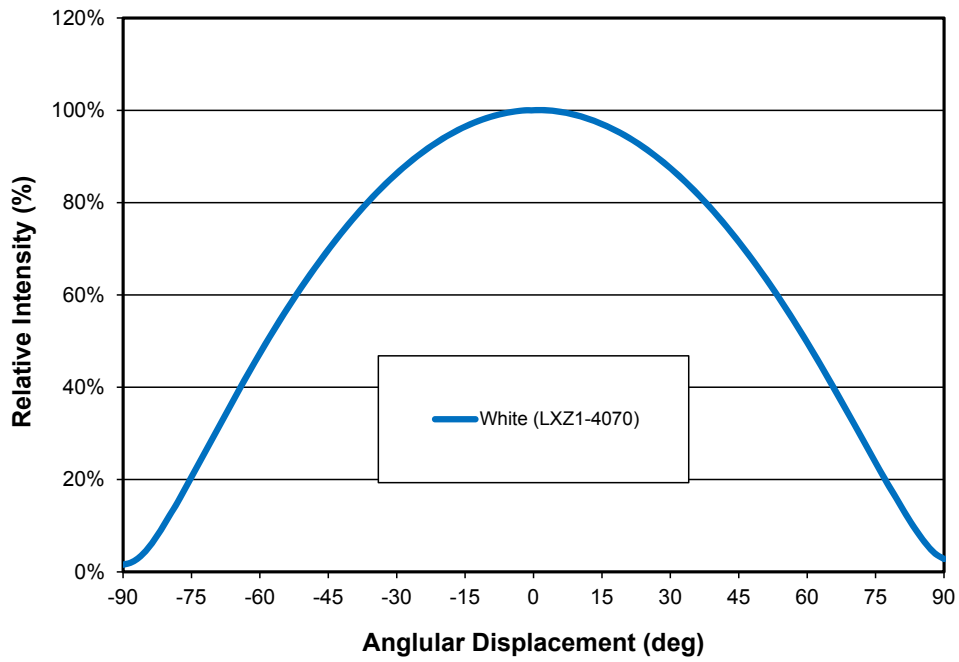

Figure 14.

LUXEON Z Typical Polar Radiation Pattern

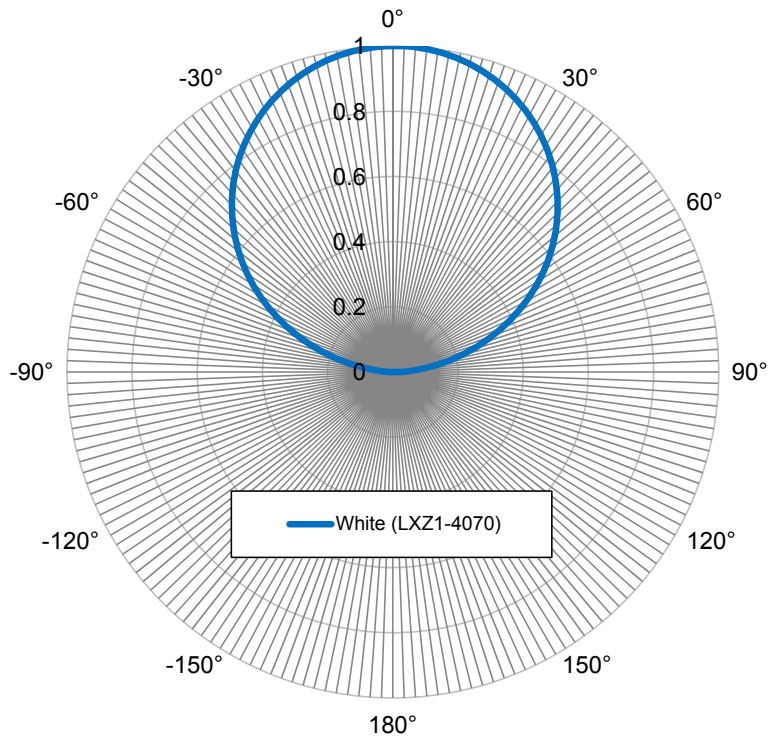

Figure 15.

Emitter Pocket Tape Packaging for LUXEON Z ES

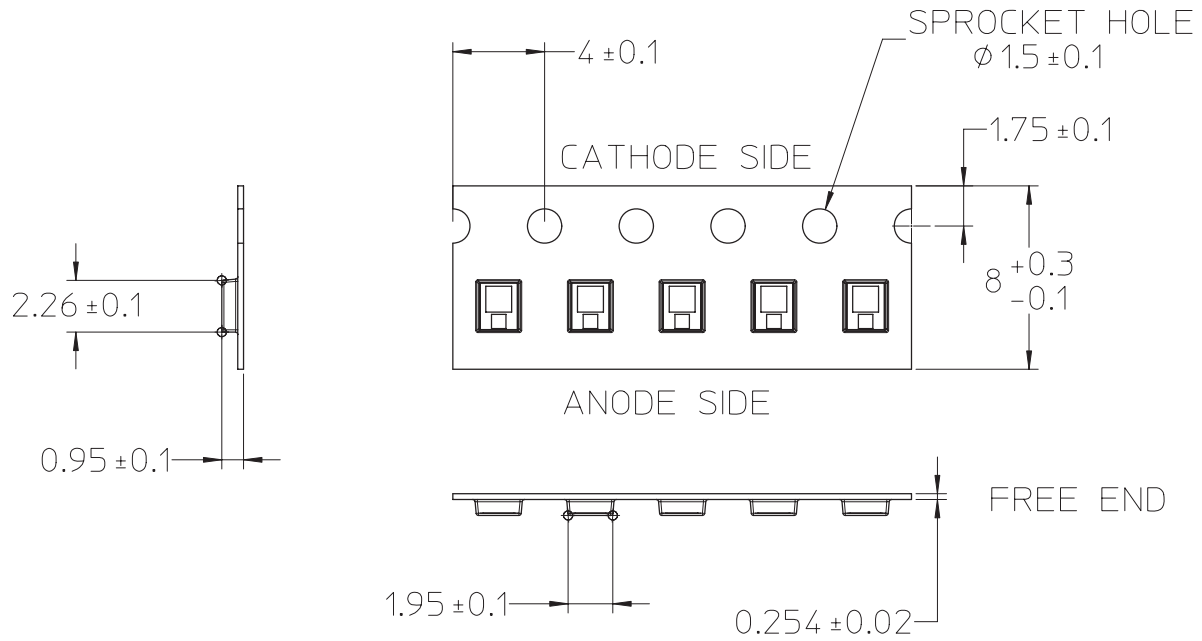

Figure 16. Emitter pocket tape packaging for LUXEON Z ES.

Notes for Figure 16:

1. All dimensions are in millimeters

Emitter Reel Packaging for LUXEON Z ES

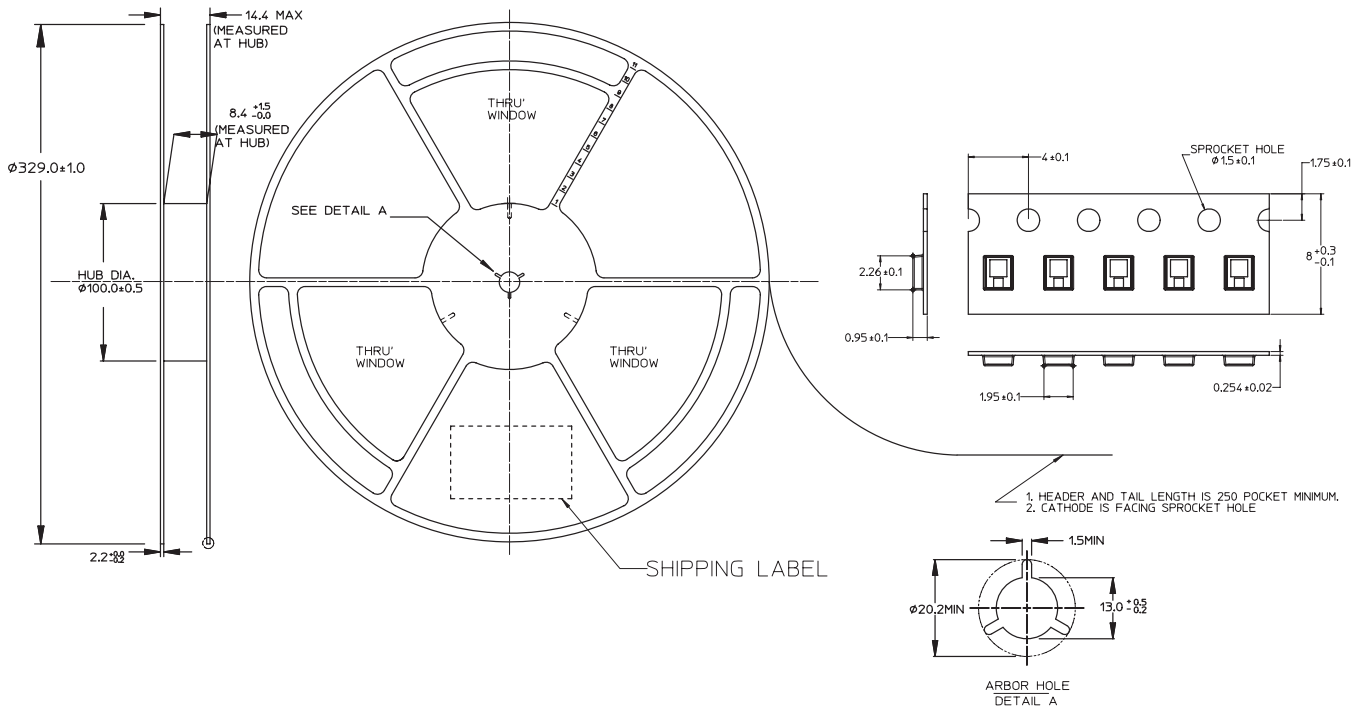

Figure 17. Emitter reel packaging for LUXEON Z ES.

Emitter Pocket Tape Packaging for LUXEON Z

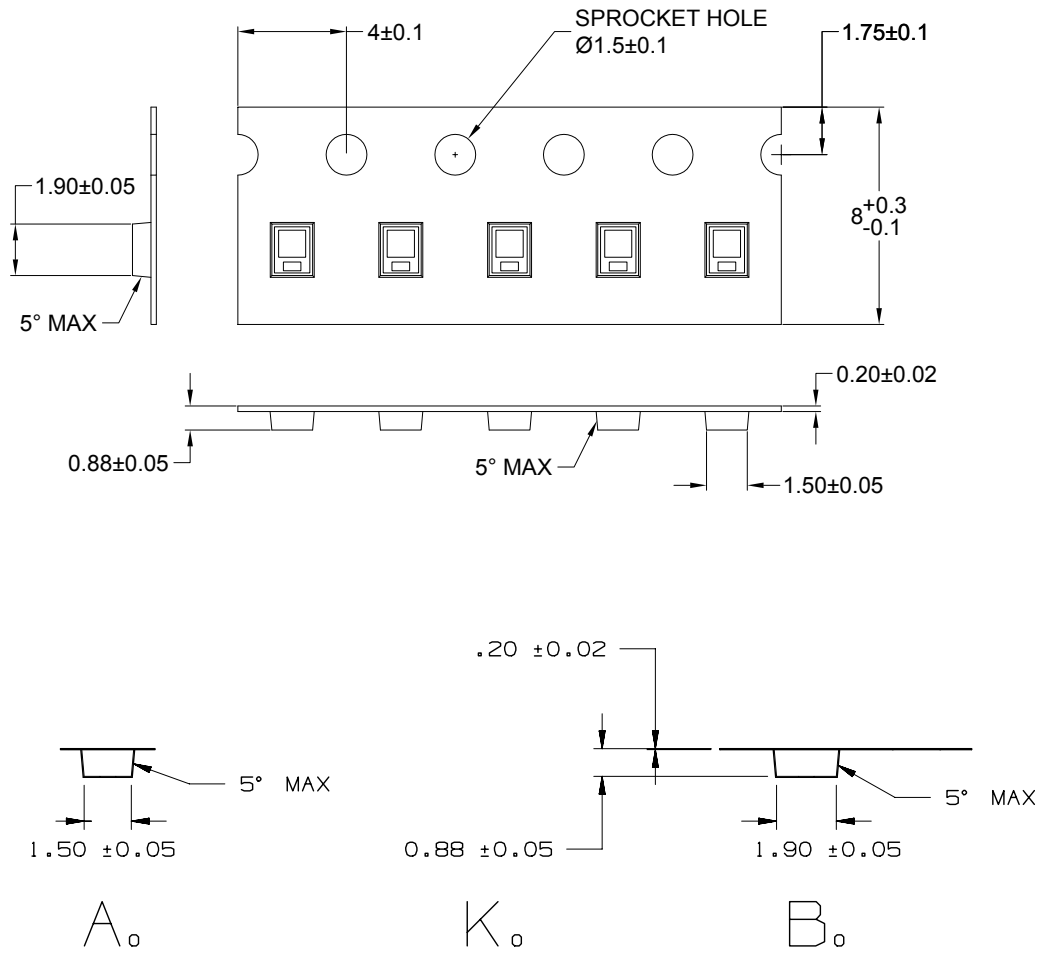

Figure 18. Emitter pocket tape packaging for LUXEON Z.

Notes for Figure 18:

- I. All dimensions are in millimeters

Emitter Reel Packaging for LUXEON Z

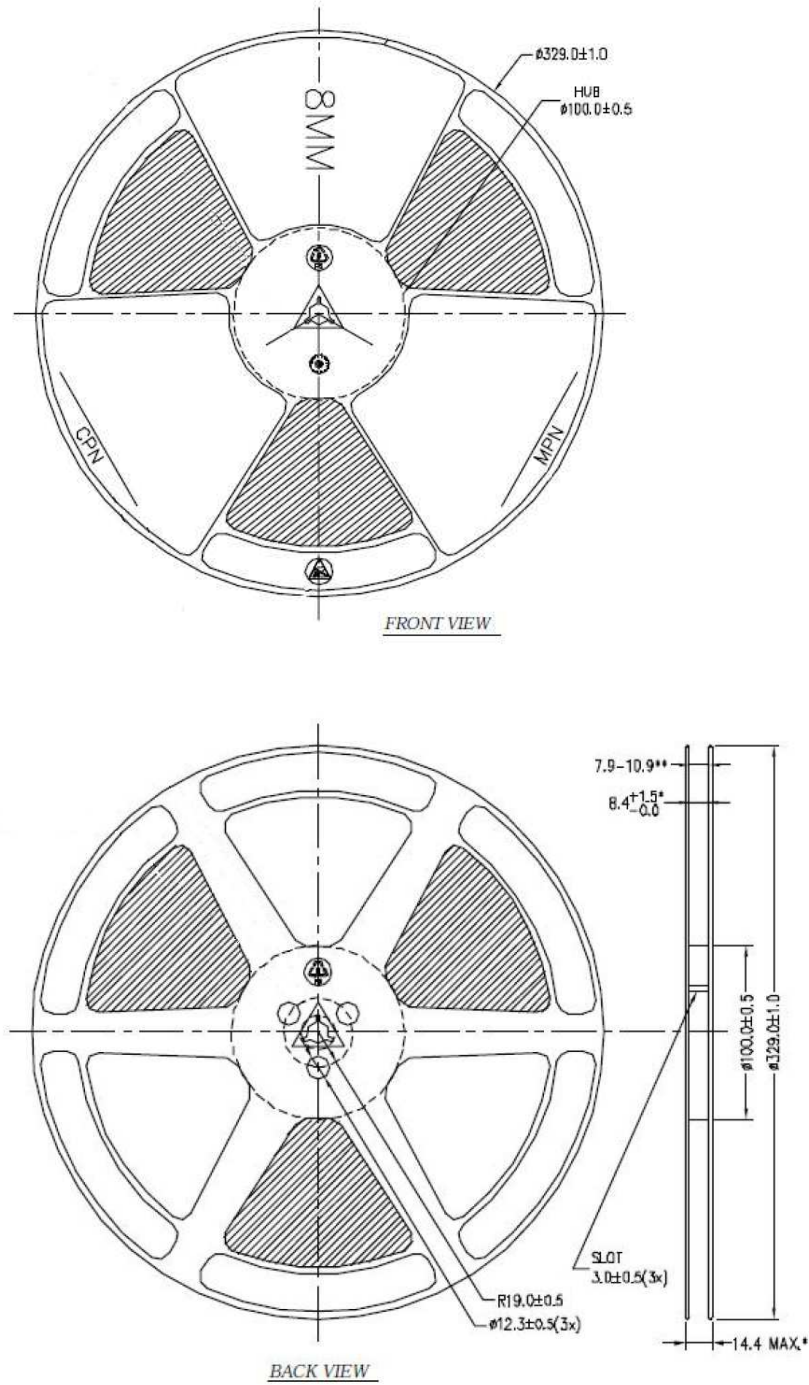

Figure 19. Emitter reel packaging for LUXEON Z.

Product Binning and Labeling

Purpose of Product Binning

In the manufacturing of semiconductor products, there are variations in performance around the average values given in the technical data sheets. For this reason, Philips Lumileds bins the LED components for luminous flux and forward voltage (V_f). Color is offered in a single 1 step, 3-step or 5-step MacAdam ellipse color space centered on the ANSI CCT color bins. For additional information please review the MacAdam ellipse technical definition section.

Decoding Product Bin Labeling

LUXEON Z ES and LUXEON Z emitters are labeled using a four digit alphanumeric code (CAT code) depicting the bin values for emitters packaged on a single reel. All emitters packaged within a reel are of the same 3-variable bin combination. Reels of LUXEON Z emitters are labeled with a four digit alphanumeric CAT code following the format below.

ABCD

A = Flux/Radiometric power bin (L, M, etc.)

B and C = Color Bin (5A, 5B, 5C, 5D, 50, 30, 3U, 3L, 10)

D = V_f bin (P, R, S)

Table 7. LUXEON Z and Z ES Cat Code Logic

A	B	C	D
	1 for 1 step	0 for 1 step	
Flux bin per DS	3 for 3 step	0 for 70 CRI U or L (above (U) or below (L) black body line) for 80 CRI	V_f bin
	5 for 5 step	A/B/C/D (5 step quadrant for 80 and 90 CRI), 0 for 70 CRI or less	

70 CRI:

1. Only 5 step available i.e. eg: LXZ2-4070 etc will, by default, mean 5 step.
2. 3 step and 1 step are sub sets of 5 step hence the cat code will state 30 or 10 if the part is actually 3 or 1 step .

80/90 CRI:

1. 1 step available in 2780/90, 3080/90, 3580 only. Please contact your Philips Lumileds Sales representative for support.
2. 3U and 3L will be the color bin cat codes. For product below black body below work with your distribution representative on supportability per volume requirements.

Luminous Flux and Forward Voltage Bins

Table 8 lists the standard photometric luminous flux bins for LUXEON Z ES and LUXEON Z emitters (tested and binned at 700 mA and 500 mA, respectively, and $T_j = 85^\circ\text{C}$). Although several bins are outlined, product availability in a particular bin varies by production run and by product performance. Not all bins are available in all colors.

Table 8. Flux Bins

Bin Code	Minimum Photometric Flux (lm)	Maximum Photometric Flux (lm)
A	100	110
B	110	120
C	120	130
D	130	140
E	140	150
F	150	160
G	160	170
H	170	180
J	180	190
K	190	200
L	200	210
M	210	220
N	220	230
P	230	240

Table 9 lists minimum and maximum V_f bin values per emitter. Although several bins are outlined, product availability in a particular bin varies by production run and by product performance.

Table 9. V_f Bins

Bin Code	Minimum Forward Voltage (V)	Maximum Forward Voltage (V)
P	2.50	2.75
R	2.75	3.00
S	3.00	3.25

LUXEON Z and LUXEON Z ES: 1-step, 3-step (above and below blackbody) and 5-step MacAdam Ellipse Color Definition

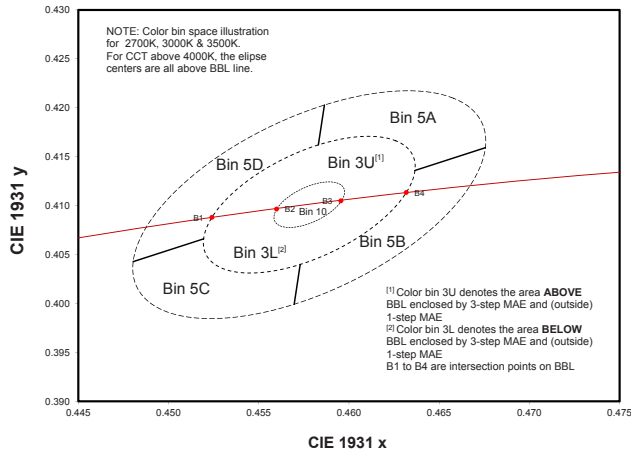

Color Space Definition for Above and Below Blackbody

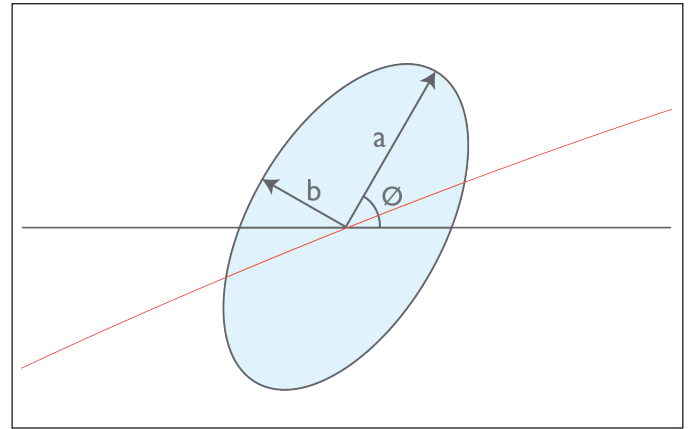

Parameter Definition of MacAdam Ellipse

Table 10. LUXEON Z and LUXEON Z ES 1-step MacAdam Ellipse Parameters

Nominal ANSI CCT	Color Space	Center Point (cx, cy)	Major Axis, a	Minor Axis, b	Ellipse Rotation Angle (degrees)
2700K	Single 1-step MacAdam ellipse	(0.4578, 0.4101)	0.00270	0.00140	53.70
3000K	Single 1-step MacAdam ellipse	(0.4338, 0.4030)	0.00278	0.00136	53.22
3500K	Single 1-step MacAdam ellipse	(0.4073, 0.3917)	0.00309	0.00138	54.00

Only available in 80 and 90 CRI.

Table 11. LUXEON Z and LUXEON Z ES 3-step MacAdam Ellipse Parameters

Nominal ANSI CCT	Color Space	Center Point (cx, cy)	Major Axis, a	Minor Axis, b	Ellipse Rotation Angle (degrees)
2700K	Single 3-step MacAdam ellipse	(0.4578, 0.4101)	0.00810	0.00420	53.7
3000K	Single 3-step MacAdam ellipse	(0.4338, 0.4030)	0.00834	0.00408	53.2
3500K	Single 3-step MacAdam ellipse	(0.4073, 0.3917)	0.00927	0.00414	54.0
4000K	Single 3-step MacAdam ellipse	(0.3818, 0.3797)	0.00939	0.00402	53.7
5000K	Single 3-step MacAdam ellipse	(0.3447, 0.3553)	0.00822	0.00354	59.6

Only available in 80 and 90 CRI.

Table 12. LUXEON Z and LUXEON Z ES 5-step MacAdam Ellipse Parameters

Nominal ANSI CCT	Color Space	Center Point (cx, cy)	Major Axis, a	Minor Axis, b	Ellipse Rotation Angle (degrees)
2700K	Single 5-step MacAdam ellipse	(0.4578, 0.4101)	0.01350	0.00700	53.7
3000K	Single 5-step MacAdam ellipse	(0.4338, 0.4030)	0.01390	0.00680	53.2
3500K	Single 5-step MacAdam ellipse	(0.4073, 0.3917)	0.01545	0.00690	54.0
4000K	Single 5-step MacAdam ellipse	(0.3818, 0.3797)	0.01565	0.00670	53.7
5000K	Single 5-step MacAdam ellipse	(0.3447, 0.3553)	0.01370	0.00590	59.6
5700K	Single 5-step MacAdam ellipse	(0.3287, 0.3417)	0.01243	0.00533	59.09

Available in 70, 80 and 90 CRI.

Note for Tables 10, 11 & 12:

- Philips Lumileds maintains a tester tolerance of ± 0.005 on x, y color coordinates.



Who We Are

Philips Lumileds focuses on one goal: Creating the world's highest performing LEDs. The company pioneered the use of solid-state lighting in breakthrough products such as the first LED backlit TV, the first LED flash in camera phones, and the first LED daytime running lights for cars. Today we offer the most comprehensive portfolio of high quality LEDs and uncompromising service.

Philips Lumileds brings LED's qualities of energy efficiency, digital control and long life to spotlights, downlights, high bay and low bay lighting, indoor area lighting, architectural and specialty lighting as well as retrofit lamps. Our products are engineered for optimal light quality and unprecedented efficacy at the lowest overall cost. By offering LEDs in chip, packaged and module form, we deliver supply chain flexibility to the inventors of next generation illumination.

Philips Lumileds understands that solid state lighting is not just about energy efficiency. It is about elegant design. Reinventing form. Engineering new materials. Pioneering markets and simplifying the supply chain. It's about a shared vision. Learn more about our comprehensive portfolio of LEDs at www.philipslumileds.com.

Philips Lumileds Lighting Company shall not be liable for any kind of loss of data or any other damages, direct, indirect or consequential, resulting from the use of the provided information and data. Although Philips Lumileds Lighting Company has attempted to provide the most accurate information and data, the materials and services information and data are provided "as is" and Philips Lumileds Lighting Company neither warranties, nor guarantees the contents and correctness of the provided information and data. Philips Lumileds Lighting Company reserves the right to make changes without notice. You as user agree to this disclaimer and user agreement with the download or use of the provided materials, information and data.



©2013 Philips Lumileds Lighting Company. All rights reserved.
LUXEON is a registered trademark of the Philips Lumileds Lighting Company in the United States and other countries.

www.philipslumileds.com
www.philipslumileds.cn.com

LUXEON Z and LUXEON Z ES Datasheet DS120 20131205