

## Model 5145 Incapsulated Double Banana Plug Shorting Bar

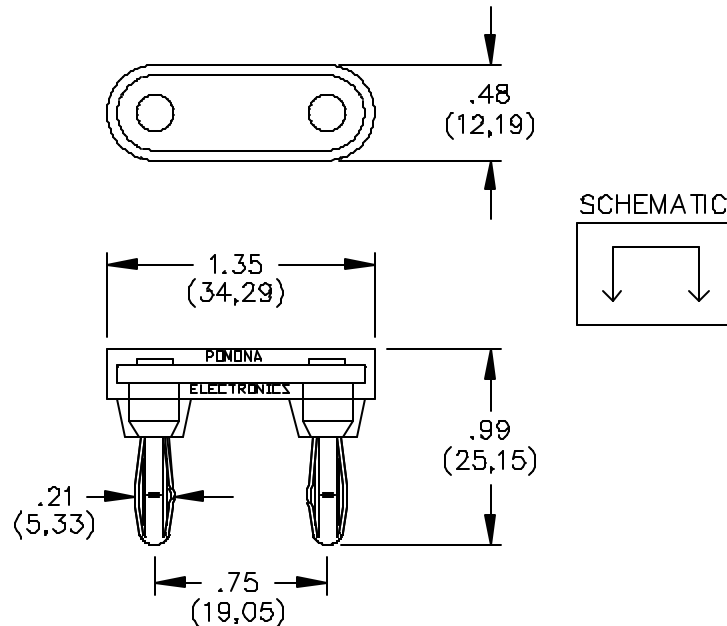

### FEATURES:

- Low profile, completely insulated shorting bar.
- Insulation has finger ridge for ease of insertion and removal.
- Mates to Model #2269 or any standard double banana jack.

### MATERIALS:

#### Shorting Bar:

Material: Brass per QQ-B-613, Composition 2, ½ Hard.

Finish: Nickel plated per QQ-N-290, Class 2, 200/300 microinches.

#### Insulation:

Polypropylene molded to banana plugs and shorting bar. Color: Clear

Marking: "POMONA ELECTRONICS" "MODEL 5145".

#### Banana Plugs:

Material: Spring – Beryllium Copper per QQ-C-533, Berylco 25, Cond. H.T.

Plug Body – Brass per QQ-B-626, Alloy 360, ½ Hard.

Finish: Nickel plated per QQ-N-290, Class 2, 200/300 microinches.

### RATINGS:

Operating Temperature: +50°C. (+122°F.) Max.

Current: 15 Amperes

Resistance: Less than 1.5 milliohms installed.

### ORDERING INFORMATION: Model 5145

All dimensions are in inches. Tolerances (except noted): .xx = ±.02" (.51 mm), .xxx = ±.005" (.127 mm).

All specifications are to the latest revisions. Specifications are subject to change without notice.

Registered trademarks are the property of their respective companies. Made in USA