



Technik braucht Kontrolle: A great deal of research and development has been undertaken at TELE and it benefits further from its production base in Austria and a strong team that brings its products to the market. The company grew with time relays and automation components and the focus on monitoring technology still characterizes the company today. As a pioneer and trendsetter, it is able to deliver intelligent solutions for monitoring plants, factories, buildings and machines and keeping them running.

TELE produces up-to-the-minute monitoring and control equipment that satisfies international standards for worldwide deployment at the highest levels of quality – from a passion and out of professionalism.

Established in 1963 as a family owned company, the headquarters and production base in Vienna has generated branches in Germany and Great Britain and a dense network of more than 60 dealers all over the world. Long-standing customers from all areas of industry and fresh ideas for difficult tasks have made us what we are today – a reliable and flexible partner. Here, the striking green design is the external expression of internal values – quality and innovation constitute the basis for our many years of success and our orientation towards the future.

TELE • Vorarlberger Allee 38 • 1230 Vienna • Austria
Tel. +43 (0)1 614 74 - 0 • Fax +43 (0)1 614 74 - 100
www.tele-online.com

TELE - Main Catalogue - 2011 / 2012



MAIN CATALOGUE 2011/2012





Connecting the Dots

Changes, whether social, technological, ecological or economic, define our evolution at all times.

People, institutions and businesses are being challenged now more than ever to not only accept this change but to actively contribute to shaping it.

Clean and intelligent technologies contribute essentially to efficiently defining products and solutions in the long-term in order to make our environment a better place to live.

Question the existing • Record trends • Anticipate the future.
Recognize dependencies and make connections.

This is how our ideas evolve • This is how TELE develops products.

Christoph Haase

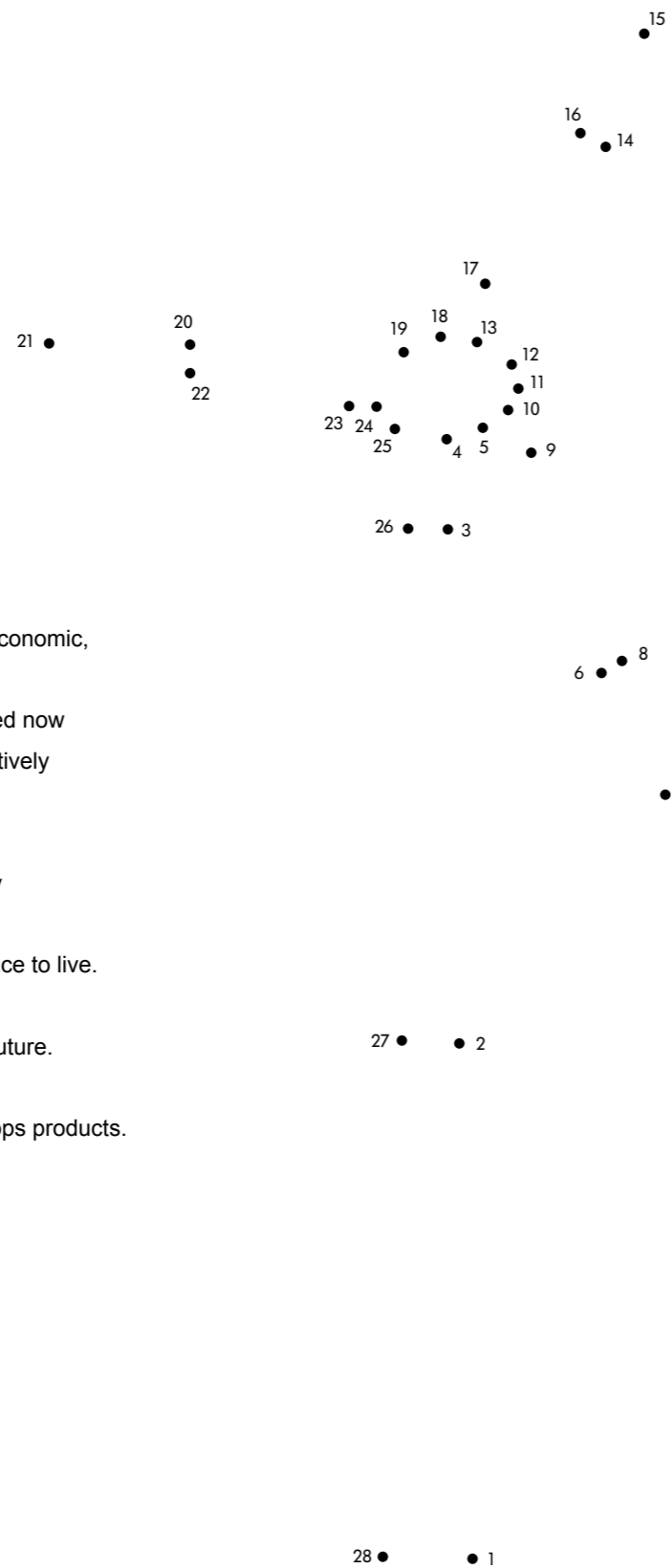

Table of Content

| | | | |
|--|---|--|-----------------|
| US | - About TELE | | Page 4 |
| News | - Highlights from Tele | | Page 6 |
| TELE offers... | | | |
| 1. Sensing & Monitoring relays | - Voltage - Current - Temperature - Level | | Page 9 |
| 2. Loadmonitors | - True power - Power factor (cos φ) | | Page 87 |
| 3. Time relays | - Time relays - Star Delta relays - Staircase timer - Emergency light tester | | Page 105 |
| 4. Monitoring systems and control units | - WatchDog pro - Energy management ECO III - Sequence processor STEP-T8 - Pump Alternator | | Page 157 |
| 5. Power electronic | - Softstarter - Braking units - Thyristor control units | | Page 209 |
| 6. Switching relays and other automation components | - Switching relays - Coupling units - Safety relays - Signal converter - Digital time switches - Hour meters - Power supplies | | Page 219 |
| 7. Accessories | - PowerModules - Probes - Current transformers - Other | | Page 249 |
| Index | | | Page 254 |



US

Günther Haase, Founder

EXPERIENCE

TELE has been going strong since 1963. We believe that's long enough to boast, "We know what we're doing!" We have the biggest product range of any provider in the field of timing and monitoring relays – Worldwide. Like us, all our products are 100% Austrian made. That is a claim we are very proud of, just as we are proud that we have been the market leader in Austria for decades – by a long shot.



STANDARDS

Bettina Putz, Customer Service

Over 25% of our turnover is made with products tailored to our customer's unique specifications. This is quite a large percentage and is one of our strengths. We have customers in over 60 countries and we take care to develop a special relationship with each one – a relationship based on partner-ship, reliability and always to everyone's mutual benefit. We call it our "handshake guarantee" and it is of the utmost importance to us.



GIVE AND TAKE

Aranka Copor, Assembly

Dieter Dollansky, SMD Assembly

"Intelligent solutions with added value for our customers." Behind this stuffy corporate statement stands nothing more than the high standards of over 100 colleagues. We constantly strive to exceed the expectations of our customers and, well, succeed most of the time. We try to put our all into everything we do. Word of honour.



OUTLOOK

Christian Mari, Head of Procurement

We can tell you today what you can expect from us in the future. We will continue to do what we do best: Support the supply of electrical energy from creation to consumption and ensure everything runs smoothly along the way. We will focus on the responsible use of energy and create solutions that encourage us all to use our planet's resources in a sustainable manner. No more, no less.

NEW



Highlights from TELE

Highlights from TELE

Load monitors

“The motor as sensor”

Monitoring motors' efficiency or effective power makes it possible to draw a number of useful conclusions regarding the state of drives, machines and installations, and these can often be used to reduce the cost of maintenance, servicing and downtime.

Benefits and added value are illustrated by means of sample applications such as waste compressors or grinders, agitators, conveyor belts, ventilation and exhaust systems, machine tools, overhead and gantry cranes, and centrifugal and reciprocating pumps.



more info on
Page 87

more info on
Page 63 & 135

UL certification

Extensions to the product range for North America and Canada. Specifically, the ENYA installation series is being extended to provide cULus certification. Together with the industrial series GAMMA and the compact industrial series DELTA it now constitutes a full-range package for the export economy.



NEW

NEW

AUTOMATIC DISCONNECTION DEVICE

Product portfolio for the safe monitoring of power grids receiving power from small-scale power stations such as photovoltaic or wind generators. Internationally certificated under the national standards of Austria, Germany and Italy.

Although there are a large number of relevant standards, the decision as to exactly how a grid should be monitored is the responsibility of the appropriate utility company.



more info in our
new folder

more info on
Page 99

(Load) current to 4 - 20 milliamps

The input stage can measure AC currents up to 15 A over three switchable ranges. The conversion range can be optimally adjusted to the 4-20mA output by means of a zero/span function. Input, output and supply are separated three ways. The converter's versatility makes it an optimal adjunct to process automation applications.



NEW

NEW

True-off relays D6A, K3ZA and G2ZA

“True OFF”, “relay timing without supply voltage” and similar expressions all refer to the same simple timing function, but vendors need many years' experience before they can offer this straightforward function in the form of a timing relay that is sufficiently robust for industrial use. TELE has been working with this type of timing relay for decades, and is also including it in its new series.



more info on
Pages 113, 125 & 131

more info on
Page 21

Wide-range voltage monitoring

The product portfolio of the industrial series GAMMA has been extended to include the G2PU690VS20, which offers voltage monitoring over a remarkably wide range, namely 208 V to 690 V. This unit is also able to draw its power from the voltage being measured (supply voltage = measured voltage). This enables it to cover a wide range of applications for both conventional power grids at 230/400 V or 240/415 V and special industrial power supplies up to 400/690 V.



NEW

NEW

SENSING & MONITORING RELAYS



OVERVIEW

TELE offers the widest range of products with the following performance features:

- Measurement of one or more quantities such as voltage, current, temperature and filling levels
- Internal or external power supply (e.g. 24 V DC)
- Monitor the voltage of ordinary mains grids at 230/400 V or 240/415 V as well as special industrial power supplies at 400/690 V
- Various forms of housing for control engineering, industrial systems and machine building as well as building installations; variants available for DIN rails, front installation or an 11-pole plug-in base

The robust design with generous terminal space throughout ensures very good usability and installability.



Page

| | | |
|---|--|----------------------------------|
| Monitoring Relays <i>WatchDog</i> | Introduction | 10 |
| Selection matrix | Quick, explicit and time-saving to the right product. | 12 |
| Function overview | Explanations of important terms | 16 |
| Industrial Series: GAMMA | - Voltage 3-phase - Voltage 1-phase - Current 1-phase - Current 3-phase - Temperature - Level | 17 27 29 33 39 41 |
| Industrial Series compact: DELTA | - Voltage 3-phase - Voltage 1-phase - Current 1-phase - Temperature - Level | 49 53 55 57 59 |
| Plugable Series: KAPPA | - Voltage 3-phase - Voltage 1-phase - Current 1-phase | 61 61 61 |
| Installation Series: ENYA | - Voltage 3-phase - Voltage 1-phase - Current 1-phase - Temperature - Level | 63 63 77 79 81 |



**WELCOME TO THE
WORLD OF THE
WATCHDOGS**

The monitoring relays with the WatchDog label can display electrical values such as current, voltage, power factor, power performance, conductivity, resistance, temperature etc., meaning these can be monitored based on a limit value and deviations displayed on a message contact.

The housing is already a sign that the system has a robust design. The overvoltage category is consistently indicated with 3 so that industrial network environments do not present a problem. With the disruptive influences burst and surge, the normative requirements are more than fulfilled. The operating safety of

the devices is thus ensured even with high disruption potential.

One difference that makes a difference. The temperature range in which the devices can be operated is between -25°C and +55°C.

The spacious operating front permits the accommodation of many setting options and display elements. A clear display with a separate LED for each operating mode is thus possible. There is only one rule here, and this has been valid with TELE for years: flashing LED means 'time running', continuously illuminated LED means 'time expired'. The operating elements have a flush arrangement in the

front, whereby up to 5 setting elements are possible in a 22.5 mm construction width. This permits maximum functionality on minimum space. As supply variants for the auxiliary voltage, CoolZoom with 24-240VAC/DC or the power modules with nominal voltages of up to 400V(TR2) or 500V(TR3) are available.

The Watchdogs are now also being used in the installation construction form thanks to the ENYA series. With up to 5 setting elements, an excellent operating comfort can be reached in this construction form too that is supplemented by up to four display elements.

These can also serve as a diagnosis

display in ongoing operation, in order to e.g. recognise in which phase the breakdown has occurred. ENYA devices can fit in every energy distribution cabinet and are thus ideally suited for use in building automation and control systems. They can be used to protect against an unwanted operating status, the detection of consumption points that are switched on or for classical control tasks. The application areas range from the monitoring of a four-wire network via one-phase monitoring applications to DC monitoring of battery-buffered systems. A diversity of current and voltage monitoring relays in one- and three-phase design are

available. The supply with these devices is integrated into the measuring circuit to save clamp connections.

WatchDog

coolZoom

The components mounted in a switching cabinet lead in total to a substantial heat development that has a negative impact on the lifecycle of the entire control unit. Through the use of state-of-the-art switching power supply technology, TELE reduces the energy consumption and thus also the heat development. The typical power consumption of the new products thus lies below the 1W mark – simply 'cool'. The lower operating temperature firstly has a positive effect on the lifecycle and reliability of the components and secondly results in substantial savings potential in the switching cabinet air climate control system and ventilation. Another benefit is demonstrated in the use of products in battery-buffered systems. Due to the lower power consumption, the battery

can be designed in a smaller size with extended follow-up time.

With their extreme adaptability (zoom) to any voltage supply

in the range of 24 to 240VAC/DC, generous tolerance ranges (20.4 to 264VAC or 19.2 to 300VDC) and their usage options in the frequency range of 16 2/3 to 400Hz, the devices from TELE are suitable for any conceivable application.

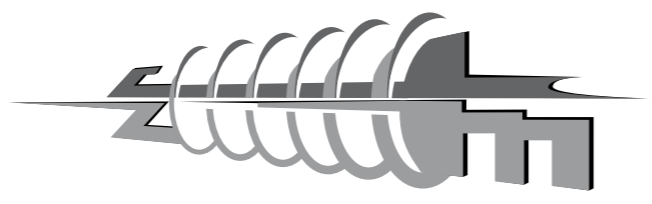

PowerModules

In a simple and cost-effective manner, you adapt the WatchDog monitoring relays and load sentinels and the timing relays of the GAMMA series to the respective supply voltage. The plug-in power modules TR2 and TR3 are available for this and they only have to be inserted into the lateral supply slot of the devices.

The power modules TR2, with selectable nominal voltages of 12 to 440VAC, are envisaged for designs in 22.5mm construction width, while the power modules TR3 with nominal voltages of up to 500 V are suitable for types with a 45-mm wide housing. The supply voltage can therefore also be taken up by the outer conductor voltage if a neutral cable is not necessary in the application. The power modules work particularly 'quietly' in the

network, which means they are entirely suited for class B applications according to EN 55011 (living area). Another advantage: In the event of maintenance, the plug-in power module can be quickly and conveniently replaced. You simply order the right plug-in power modules for your application separately.

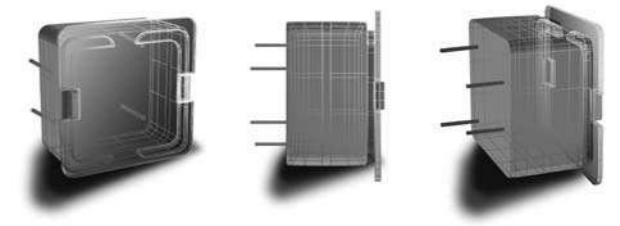

SERIES Design

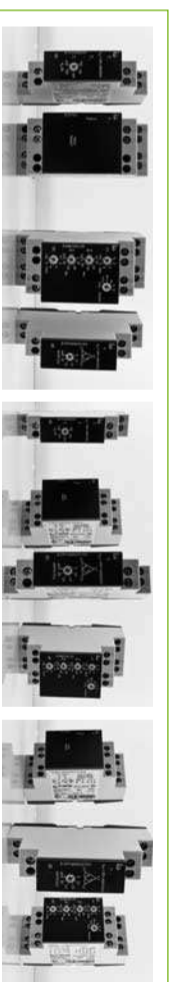

SENSING & MONITORING RELAYS

TREND
Industry compact

KAPPA
Industry plug-in

ENYA
Insulation

Functions

| Functions | Voltage | | Current | Temperature | Level |
|------------------------------|---------|---------|---------|-------------|-------|
| | 3-phase | 1-phase | | | |
| Over (OVER) | | | | | |
| Under (UNDER) | | | | | |
| Window (WIN) | | | | | |
| Reverse Window | | | | | |
| Phase sequence (SEQ) | | | | | |
| Phase failure | | | | | |
| Asymmetry (ASYM) | | | | | |
| Fault latch (LATCH) | | | | | |
| Adjustable thresholds | | | | | |
| Adjustable hysteresis | | | | | |
| Start-up suppression (START) | | | | | |
| Tripping delay (DELAY) | | | | | |
| On delay (ON DELAY) | | | | | |
| Testfunction (TEST/ RESET) | | | | | |
| Short circuit monitoring | | | | | |
| Zero-voltage latch | | | | | |

Output

| | |
|---------------|--|
| 1 CO contact | |
| 2 CO contacts | |
| 1 NO contact | |

cULus - Certificates

Measured range

| Type | Supply voltage | Measured range | Output | cULus - Certificates |
|-------------------|------------------------------------|--|---------------|----------------------|
| TPW400VSN4X | 12 - 440V AC, 24V DC ¹⁾ | 3(N)~ 230/400V AC (48 - 63Hz) | 1 CO contact | |
| TPW230VSN4X | 12 - 440V AC, 24V DC ¹⁾ | 3(N)~ 133/230V AC (48 - 63Hz) | 2 CO contacts | |
| TPW115VSN4X | 12 - 440V AC, 24V DC ¹⁾ | 3(N)~ 66/115V AC (48 - 63Hz) | 1 NO contact | |
| TPW400VN4X | 12 - 440V AC, 24V DC ¹⁾ | 3(N)~ 230/400V AC (48 - 63Hz) | | |
| TPF230VS4X | 3~ 230V AC | 3~ 132/230V AC (48 - 63Hz) | | |
| TPF400VS4X | 3~ 400V AC | 3~ 230/400V AC (48 - 63Hz) | | |
| TUW4X | 12 - 440V AC, 24V DC ¹⁾ | 24V; 115V; 230V; 440V AC/DC (48 - 63Hz) | | |
| TUH4X | 12 - 440V AC, 24V DC ¹⁾ | 30V; 60V; 300V; 600V AC/DC (48 - 63Hz) | | |
| TIW4X | 12 - 440V AC, 24V DC ¹⁾ | 100mA; 1A; 10AAC/DC (48 - 63Hz) | | |
| TIH4X | 12 - 440V AC, 24V DC ¹⁾ | 100mA; 1A; 10AAC/DC (48 - 63Hz) | | |
| TIF30-300mAAC4X | 230V AC | 15A AC (48 - 63Hz) | | |
| TDT4X | 12 - 440V AC, 24V DC ¹⁾ | 2 x PTC (motortemperature) $\Sigma R < 1,5k\Omega$ | | |
| TT2X 24V AC | 24V AC | PTC (motortemperature) $\Sigma R < 1,5k\Omega$ | | |
| TT2X 230V AC | 230V AC | PTC (motortemperature) $\Sigma R < 1,5k\Omega$ | | |
| TLH4X 24V AC | 24V AC | 0,25 - 5k Ω / 5 - 100k Ω (conductiv probe) | | |
| TLH4X 230V AC | 230V AC | 0,25 - 5k Ω / 5 - 100k Ω (conductiv probe) | | |
| TLC4X 230V AC | 230V AC | 5 - 100k Ω (conductiv probe) | | |
| K3YM400VSY20 | 3(N)~ 230/400V AC | 3(N)~ 230/400V AC (48 - 63Hz) | | |
| K3PF400VSY02 | 3(N)~ 230/400V AC | 3(N)~ 230/400V AC (48 - 63Hz) | | |
| K3UM230VAC02 | 230V AC | 230V AC (48 - 63Hz) | | |
| K3UM24VDC02 | 24V DC | 24V DC | | |
| K3IM5AAACL20 230V | 230V AC | 5AAC (48 - 63Hz) | | |

| Current | Voltage | |
|---------|---------|---------|
| | 3-phase | 1-phase |
| 1 | | |

| Voltage | Current | |
|---------|---------|---------|
| | 1-phase | 1-phase |
| 3-phase | | |

| Level | Temp. | |
|-------|---------|---------|
| | 1-phase | 1-phase |
| | | |

Functions

| Functions | Voltage | | Current | Temp. | Level |
|------------------------------|---------|---------|---------|-------|-------|
| | 3-phase | 1-phase | | | |
| Over (OVER) | | | | | |
| Under (UNDER) | | | | | |
| Window (WIN) | | | | | |
| Reverse Window | | | | | |
| Phase sequence (SEQ) | | | | | |
| Phase failure | | | | | |
| Asymmetry (ASYM) | | | | | |
| Fault latch (LATCH) | | | | | |
| Adjustable thresholds | | | | | |
| Adjustable hysteresis | | | | | |
| Start-up suppression (START) | | | | | |
| Tripping delay (DELAY) | | | | | |
| On delay (ON DELAY) | | | | | |
| Testfunction (TEST/ RESET) | | | | | |
| Short circuit monitoring | | | | | |
| Zero-voltage latch | | | | | |

Output

| | |
|---------------|--|
| 1 CO contact | |
| 2 CO contacts | |
| 1 NO contact | |

cULus - Certificates

Measured range

| Type | Supply voltage | Measured range | Output | cULus - Certificates |
|----------------------|------------------|--|---------------|----------------------|
| E3YF400V02 0.85 | = measured range | 3N~ 230/400V AC (48 - 63Hz) | 1 CO contact | |
| E3YF400VE20 0.85 | = measured range | 3N~ 230/400V AC (48 - 63Hz) | 2 CO contacts | |
| E3YF400VT02 0.85 | = measured range | 3N~ 230/400V AC (48 - 63Hz) | 1 NO contact | |
| E3YF400VT02 HTV 0.85 | = measured range | 3N~ 230/400V AC (48 - 63Hz) | | |
| E1YF400V01 0.85 | = measured range | 3N~ 230/400V AC (48 - 63Hz) | | |
| E1YF400VT01 0.85 | = measured range | 3N~ 230/400V AC (48 - 63Hz) | | |
| E1YF400V01 0.70 | = measured range | 3N~ 230/400V AC (48 - 63Hz) | | |
| E3YM230VS20 | = measured range | 3(N)~ 132/230V AC (48 - 63Hz) | | |
| E1YM400VS10 | = measured range | 3(N)~ 230/400V AC (48 - 63Hz) | | |
| E1YM480Y/277VS10 | = measured range | 3~ 277/480V AC (48 - 63Hz) | | |
| E3YU400V02 | = measured range | 3(N)~ 230/400V AC (48 - 63Hz) | | |
| E1YU400V01 | = measured range | 3(N)~ 230/400V AC (48 - 63Hz) | | |
| E3YF400VFAL02 | = measured range | 3(N)~ 230/400V AC (48 - 63Hz) | | |
| E3PF400VSY02 | = measured range | 3(N)~ 230/400V AC (48 - 63Hz) | | |
| E1PF400VSY01 | = measured range | 3(N)~ 230/400V AC (48 - 63Hz) | | |
| E1PF480Y/277VSY10 | = measured range | 3~ 277/480V AC (48 - 63Hz) | | |
| E1UM230V01 | = measured range | 24V AC/DC; 230V AC (48 - 63Hz) | | |
| E1UU230V01 | = measured range | 24V AC/DC; 230V AC (48 - 63Hz) | | |
| E3IM10AL20 | 230V AC | 100mA; 1A; 10AAC/DC (16,6 - 400Hz) | | |
| E1IM10AAACL10 | 230V AC | 10AAC (48 - 63Hz) | | |
| E1IU5AAC01 | 230V AC | 5AAC (48 - 63Hz) | | |
| E1IU500mAAC01 | 230V AC | 500mA AC (48 - 63Hz) | | |
| E3TF01 | 230V AC | PTC (motortemperature) $\Sigma R < 1,5k\Omega$ | | |
| E3LM10 | 230V AC | 0,25 - 100k Ω (conductiv probe) | | |

Supply voltage

Type

Technical Data Pages

| | | | | | |
|----|-------------------|------------------------------------|--|--|--|
| 49 | TPW400VSN4X | 12 - 440V AC, 24V DC ¹⁾ | 3(N)~ 230/400V AC (48 - 63Hz) | | |
| 49 | TPW230VSN4X | 12 - 440V AC, 24V DC ¹⁾ | 3(N)~ 133/230V AC (48 - 63Hz) | | |
| 49 | TPW115VSN4X | 12 - 440V AC, 24V DC ¹⁾ | 3(N)~ 66/115V AC (48 - 63Hz) | | |
| 49 | TPW400VN4X | 12 - 440V AC, 24V DC ¹⁾ | 3(N)~ 230/400V AC (48 - 63Hz) | | |
| 51 | TPF230VS4X | 3~ 230V AC | 3~ 132/230V AC (48 - 63Hz) | | |
| 51 | TPF400VS4X | 3~ 400V AC | 3~ 230/400V AC (48 - 63Hz) | | |
| 53 | TUW4X | 12 - 440V AC, 24V DC ¹⁾ | 24V; 115V; 230V; 440V AC/DC (48 - 63Hz) | | |
| 53 | TUH4X | 12 - 440V AC, 24V DC ¹⁾ | 30V; 60V; 300V; 600V AC/DC (48 - 63Hz) | | |
| 55 | TIW4X | 12 - 440V AC, 24V DC ¹⁾ | 100mA; 1A; 10AAC/DC (48 - 63Hz) | | |
| 55 | TIH4X | 12 - 440V AC, 24V DC ¹⁾ | 100mA; 1A; 10AAC/DC (48 - 63Hz) | | |
| 55 | TIF30-300mAAC4X | 230V AC | 15A AC (48 - 63Hz) | | |
| 57 | TDT4X | 12 - 440V AC, 24V DC ¹⁾ | 2 x PTC (motortemperature) $\Sigma R < 1,5k\Omega$ | | |
| 57 | TT2X 24V AC | 24V AC | PTC (motortemperature) $\Sigma R < 1,5k\Omega$ | | |
| 57 | TT2X 230V AC | 230V AC | PTC (motortemperature) $\Sigma R < 1,5k\Omega$ | | |
| 59 | TLH4X 24V AC | 24V AC | 0,25 - 5k Ω / 5 - 100k Ω (conductiv probe) | | |
| 59 | TLH4X 230V AC | 230V AC | 0,25 - 5k Ω / 5 - 100k Ω (conductiv probe) | | |
| 59 | TLC4X 230V AC | 230V AC | 5 - 100k Ω (conductiv probe) | | |
| 61 | K3YM400VSY20 | 3(N)~ 230/400V AC | 3(N)~ 230/400V AC (48 - 63Hz) | | |
| 61 | K3PF400VSY02 | 3(N)~ 230/400V AC | 3(N)~ 230/400V AC (48 - 63Hz) | | |
| 61 | K3UM230VAC02 | 230V AC | 230V AC (48 - 63Hz) | | |
| 61 | K3UM24VDC02 | 24V DC | 24V DC | | |
| 61 | K3IM5AAACL20 230V | 230V AC | 5AAC (48 - 63Hz) | | |

| | | | | | |
|----|----------------------|------------------|--|--|--|
| 63 | E3YF400V02 0.85 | = measured range | 3N~ 230/400V AC (48 - 63Hz) | | |
| 63 | E3YF400VE20 0.85 | = measured range | 3N~ 230/400V AC (48 - 63Hz) | | |
| 63 | E3YF400VT02 0.85 | = measured range | 3N~ 230/400V AC (48 - 63Hz) | | |
| 63 | E3YF400VT02 HTV 0.85 | = measured range | 3N~ 230/400V AC (48 - 63Hz) | | |
| 65 | E1YF400V01 0.85 | = measured range | 3N~ 230/400V AC (48 - 63Hz) | | |
| 65 | E1YF400VT01 0.85 | = measured range | 3N~ 230/400V AC (48 - 63Hz) | | |
| 65 | E1YF400V01 0.70 | = measured range | 3N~ 230/400V AC (48 - 63Hz) | | |
| 67 | E3YM230VS20 | = measured range | 3(N)~ 132/230V AC (48 - 63Hz) | | |
| 67 | E1YM400VS10 | = measured range | 3(N)~ 230/400V AC (48 - 63Hz) | | |
| 67 | E1YM480Y/277VS10 | = measured range | 3~ 277/480V AC (48 - 63Hz) | | |
| 69 | E3YU400V02 | = measured range | 3(N)~ 230/400V AC (48 - 63Hz) | | |
| 69 | E1YU400V01 | = measured range | 3(N)~ 230/400V AC (48 - 63Hz) | | |
| 71 | E3YF400VFAL02 | = measured range | 3(N)~ 230/400V AC (48 - 63Hz) | | |
| 73 | E3PF400VSY02 | = measured range | 3(N)~ 230/400V AC (48 - 63Hz) | | |
| 73 | E1PF400VSY01 | = measured range | 3(N)~ 230/400V AC (48 - 63Hz) | | |
| 73 | E1PF480Y/277VSY10 | = measured range | 3~ 277/480V AC (48 - 63Hz) | | |
| 75 | E1UM230V01 | = measured range | 24V AC/DC; 230V AC (48 - 63Hz) | | |
| 75 | E1UU230V01 | = measured range | 24V AC/DC; 230V AC (48 - 63Hz) | | |
| 77 | E3IM10AL20 | 230V AC | 100mA; 1A; 10AAC/DC (16,6 - 400Hz) | | |
| 77 | E1IM10AAACL10 | 230V AC | 10AAC (48 - 63Hz) | | |
| 77 | E1IU5AAC01 | 230V AC | 5AAC (48 - 63Hz) | | |
| 77 | E1IU500mAAC01 | 230V AC | 500mA AC (48 - 63Hz) | | |
| 79 | E3TF01 | 230V AC | PTC (motortemperature) $\Sigma R < 1,5k\Omega$ | | |
| 81 | E3LM10 | 230V AC | 0,25 - 100k Ω (conductiv probe) | | |

Supply voltage

Type

Technical Data Pages

FUNCTIONS- OVERVIEW

OVER

The output relay remains switched on until the monitored value exceeds the maximum value. As soon as the monitored value falls below the minimum value, the output relay switches to the on position again.



WIN

The output relay remains switched on until the monitored value lies within the defined window. As soon as the monitored value enters the defined window again, the output relay switches to the on position again.

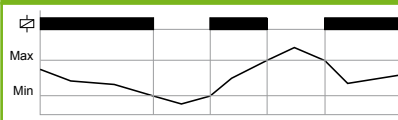

UNDER

The output relay remains switched on until the monitored value falls below the minimum value. As soon as the monitored value exceeds the maximum value, the output relay switches to the on position again.



DELAY

If the monitored value leaves the selected range, the output relay only switches to the off position following expiry of the trip delay.

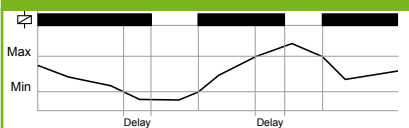

ON-DELAY

The output relay switches on if the monitored value is within the selected range during the defined time period.

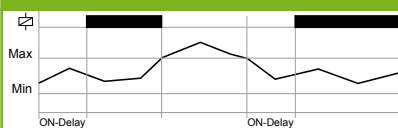

LATCH (Fault latch)

If the device detects a fault, the output relay only switches on again when the fault latch has been reset. The fault latch can be reset by means of an internal or external reset button or by interrupting the supply voltage.

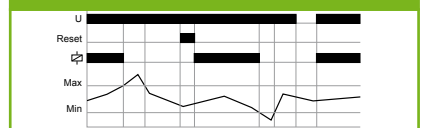

START-UP

The output relay switches on when the supply voltage is applied. Changes to measured variables have no impact on the setting of the output relay during start-up suppression.

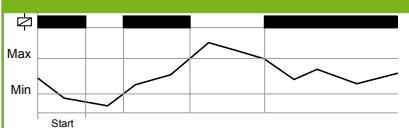

I=0 Detection

Deactivated consumers are detected with I=0 detection. As soon as the current flow is supplied again, the measurement cycle commences again with the expiry of the defined start-up suppression.



Sensing & Monitoring Relays Series GAMMA

Voltage monitoring in 3-phase mains



- Multifunction
- Monitoring of phase sequence and phase failure
- Asymmetry detection switchable
- Connection of neutral wire optional
- Detection of loss of neutral wire
- Fault latch (G4PM)
- Supply voltage selectable via PowerModules or by zoom voltage 24 to 240V AC/DC
- 1 CO contact; 2 CO contacts
- Width 22,5mm or 45mm; Industrial design

types

G4PM690VSYL20

G4PM500VSYL20

G2PM400VSY20
24-240V

G2PM400VSY20

G2PM400VSY10

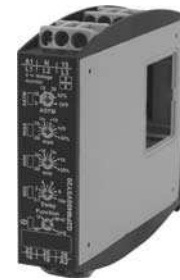

Art.No. (PQ1)

2394500

2394501

2390505

2390504

2390500

Art.No. (PQ10)

-

-

-

-

-

EAN13-Code

900866200296

900866200297

900866200284

900866200281

900866200276

Measured variable

3(N)~
AC Sinus (48 to 63Hz)

3(N)~
AC Sinus (48 to 63Hz)

3(N)~
AC Sinus (48 to 63Hz)

3(N)~
AC Sinus (48 to 63Hz)

3(N)~
AC Sinus (48 to 63Hz)

Measured range

$U_N = 690/400V$
terminals (N)-L1-L2-L3

$U_N = 500V$
terminals (N)-L1-L2-L3

$U_N = 400/230V$
terminals (N)-L1-L2-L3

$U_N = 400/230V$
terminals (N)-L1-L2-L3

$U_N = 400/230V$
terminals (N)-L1-L2-L3

Controls

ASYM • max • min •
Delay • Function

ASYM • max • min •
Delay • Function

ASYM • max • min •
Delay • Function

ASYM • max • min •
Delay • Function

ASYM • max • min •
Delay • Function

Indicators (LEDs)

ASYM • max • min • SEQ
• R

ASYM • max • min • SEQ
• R

ASYM • max • min • SEQ
• R

ASYM • max • min • SEQ
• R

ASYM • max • min • SEQ
• R

Functions

UNDER
UNDER+SEQ
WIN
WIN+SEQ
UNDER+LATCH
UNDER+SEQ+LATCH
WIN+LATCH
WIN+SEQ+LATCH

UNDER
UNDER+SEQ
WIN
WIN+SEQ
UNDER+LATCH
UNDER+SEQ+LATCH
WIN+LATCH
WIN+SEQ+LATCH

UNDER
UNDER+SEQ
WIN
WIN+SEQ

UNDER
UNDER+SEQ
WIN
WIN+SEQ

UNDER
UNDER+SEQ
WIN
WIN+SEQ

Asymmetry

5% to 25% • Off

5% to 25% • Off

5% to 25% • Off

5% to 25% • Off

5% to 25% • Off

Switching threshold max.

-20% to 30% from U_N

-20% to 30% from U_N

-20% to 30% from U_N

-20% to 30% from U_N

-20% to 30% from U_N

Switching threshold min.

-30% to 20% from U_N

-30% to 20% from U_N

-30% to 20% from U_N

-30% to 20% from U_N

-30% to 20% from U_N

Tripping delay

0,1s to 10s

0,1s to 10s

0,1s to 10s

0,1s to 10s

0,1s to 10s

Start-up suppression time

-

-

-

-

-

Fault latch

selectable

selectable

-

-

-

Supply

PowerModule TR3
terminals A1-A2

PowerModule TR3
terminals A1-A2

24 to 240V AC/DC
terminals A1-A2

PowerModule TR2
terminals A1-A2

PowerModule TR2
terminals A1-A2

Output

2 CO contacts; 250V,
5AAC

2 CO contacts; 250V,
5AAC

2 CO contacts; 250V,
5AAC

2 CO contacts; 250V,
5AAC

1 CO contact; 250V,
5AAC

Width

45mm

45mm

22,5mm

22,5mm

22,5mm

Certificates

CE • cULus • GOST

CE • cULus • GOST

CE • cULus • GOST

CE • cULus • GOST

CE • cULus • GOST

Mechanical design

Self-extinguishing plastic housing, IP rating IP40 • Mounted on DIN-Rail TS 35 in accordance with EN 60715 • Mounting position any • Shockproof terminal connection according to VBG 4 (PZ1 required), IP rating IP20 • Tightening torque max. 1Nm

Terminal capacity

1 x 0,5 to 2,5mm² with/without multicore cable end • 1 x 4mm² without multicore cable end • 2 x 0,5 to 1,5mm² with/without multicore cable end • 2 x 2,5mm² flexible without multicore cable end

Ambient conditions

Ambient temperature: -25 to 55°C (in accordance with IEC 60068-1); -25 to 40°C (in accordance with UL 508) • Storage temperature: -25 to +70°C • Transport temperature: -25 to +70°C • relative humidity: 15% to 85% (in accordance with IEC 60721-3-3 class 3K3) • Pollution degree: 3 (in accordance with IEC 60664-1) • Vibration resistance: 10 to 55Hz 0,35mm (in accordance with IEC 60068-2-6) • Shock resistance: 15g 11ms (in accordance with IEC 60068-2-27)

Accessories

PowerModules TR2 (12 - 400V AC) and TR3 (12 - 500V AC) • sealable intervention protection shield FA-G2 • DC power supply SNT2 24VDC

| | |
|-----------------|---|
| UNDER | Undervoltage monitoring |
| UNDER+SEQ | Undervoltage monitoring and monitoring of phase sequence |
| WIN | Monitoring the window between Min and Max |
| WIN+SEQ | Monitoring the window between Min and Max and monitoring of phase sequence |
| UNDER+Latch | Undervoltage monitoring with fault latch |
| UNDER+SEQ+Latch | Undervoltage monitoring and monitoring of phase sequence with fault latch |
| WIN+Latch | WIN with fault latch |
| WIN+SEQ+Latch | Monitoring the window between Min and Max and monitoring of phase sequence with fault latch |

G4PM690VSYL20 with PowerModule 24V AC G4PM690VSYL20 with PowerModule 400V G4PM500VSYL20 with PowerModule 500V AC

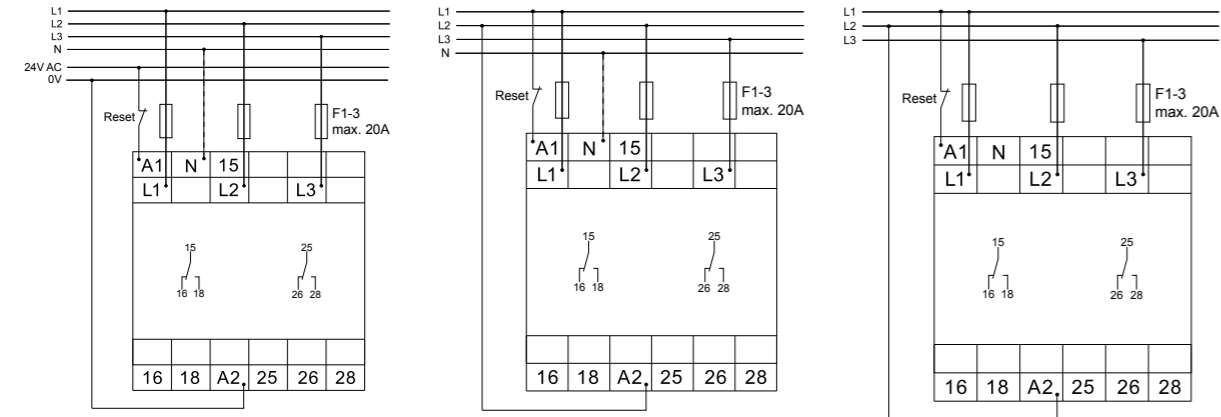

G2PM400VSY20 24V to 240V AC/DC G2PM400VSY20 with PowerModule 230V AC

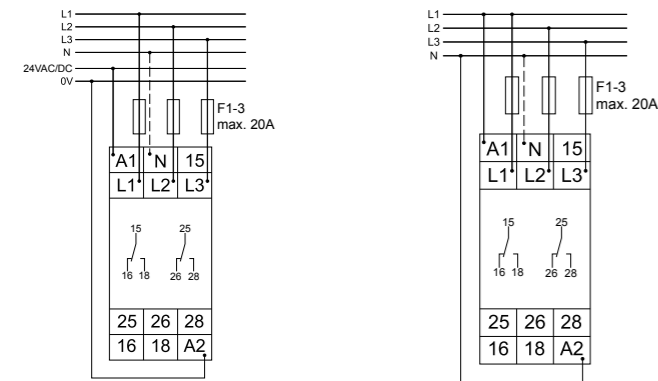

Width 22,5mm

Width 45mm

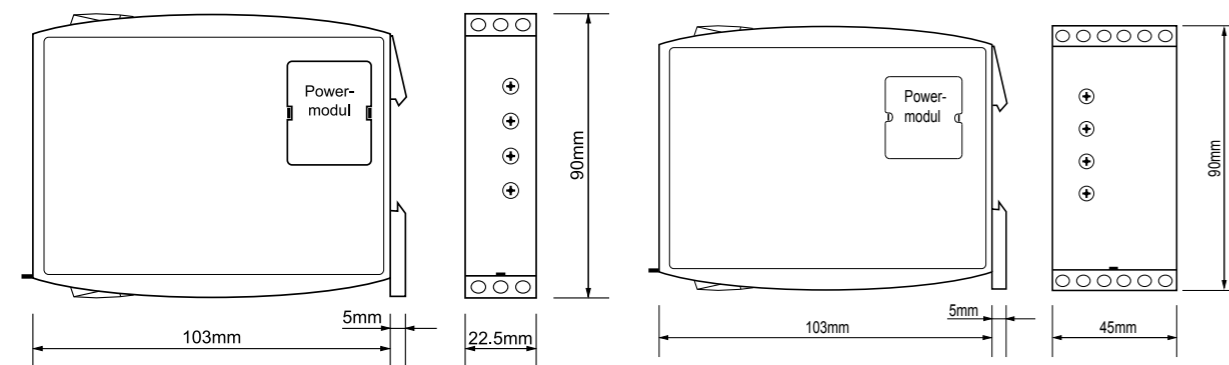

Functions



Sensing & Monitoring Relays Series GAMMA

WatchDog



Voltage monitoring in 3-phase mains

- Multifunction (G2PM); Windowfunction (G2PW)
- Monitoring of phase sequence and phase failure (G2PM)
- Asymmetry detection switchable (G2PM)
- Connection of neutral wire optional (G2PM)
- Detection of loss of neutral wire (G2PM)
- Supply voltage selectable via PowerModules or by zoom voltage 24-240V
- 1 CO contact; 2 CO contacts
- Width 22,5mm
- Industrial design

Connections

types

G2PM230VSY20 24-240V G2PM230VSY10 G2PM115VSY20 24-240V G2PM115VSY10 G2PW400V10



Art.No. (PQ1)
Art.No. (PQ10)
EAN13-Code

Measured variable

Measured range

Controls

Indicators (LEDs)

Functions

Asymmetry

Switching threshold max.

Switching threshold min.

Tripping delay

Start-up suppression time

Fault latch

Supply

Output

Width

Certificates

Mechanical design

Terminal capacity

Ambient conditions

Accessories

| Art.No. (PQ1) | 2390512 | 2390503 | 2390506 | 2390502 | 2390501 |
|---------------------------|--|---|--|---|---|
| Art.No. (PQ10) | - | - | - | - | - |
| EAN13-Code | 900866200287 | 900866200280 | 900866200516 | 900866200279 | 900866200277 |
| Measured variable | 3(N)~ AC Sinus (48 to 63Hz) | 3(N)~ AC Sinus (48 to 63Hz) | 3(N)~ AC Sinus (48 to 63Hz) | 3(N)~ AC Sinus (48 to 63Hz) | 3~ AC Sinus (48 to 63Hz) |
| Measured range | $U_N = 230/132V$ terminals (N)-L1-L2-L3 | $U_N = 230/132V$ terminals (N)-L1-L2-L3 | $U_N = 115/66V$ terminals (N)-L1-L2-L3 | $U_N = 115/66V$ terminals (N)-L1-L2-L3 | $U_N = 400/230V$ terminals L1-L2-L3 |
| Controls | ASYM • max • min • Delay • Function | ASYM • max • min • Delay • Function | ASYM • max • min • Delay • Function | ASYM • max • min • Delay • Function | max • min • Delay |
| Indicators (LEDs) | ASYM • max • min • SEQ • R | ASYM • max • min • SEQ • R | ASYM • max • min • SEQ • R | ASYM • max • min • SEQ • R | U • max • min • R |
| Functions | UNDER UNDER+SEQ WIN WIN+SEQ | UNDER UNDER+SEQ WIN WIN+SEQ | UNDER UNDER+SEQ WIN WIN+SEQ | UNDER UNDER+SEQ WIN WIN+SEQ | WIN |
| Asymmetry | 5% to 25% • Off | 5% to 25% • Off | 5% to 25% | 5% to 25% • Off | - |
| Switching threshold max. | -20% to 30% from U_N | -20% to 30% from U_N | -20% to 30% from U_N | -20% to 30% from U_N | -20% to 30% from U_N |
| Switching threshold min. | -30% to 20% from U_N | -30% to 20% from U_N | -30% to 20% from U_N | -30% to 20% from U_N | -30% to 20% from U_N |
| Tripping delay | 0,1s to 10s | 0,1s to 10s | 0,1s to 10s | 0,1s to 10s | 0,2s to 10s |
| Start-up suppression time | - | - | - | - | - |
| Fault latch | - | - | - | - | - |
| Supply | 24 to 240V AC/DC terminals A1-A2 | PowerModule TR2 or SNT2 terminals A1-A2 | 24 to 240V AC/DC terminals A1-A2 | PowerModule TR2 or SNT2 terminals A1-A2 | PowerModule TR2 or SNT2 terminals A1-A2 |
| Output | 2 CO contacts 250V, 5AAC | 1 CO contact 250V, 5AAC | 2 CO contacts 250V, 5AAC | 1 CO contact 250V, 5AAC | 1 CO contact 250V, 5AAC |
| Width | 22,5mm | 22,5mm | 22,5mm | 22,5mm | 22,5mm |
| Certificates | CE • cULus • GOST | CE • cULus • GOST | CE • cULus • GOST | CE • cULus • GOST | CE • cULus • GOST |
| Mechanical design | Self-extinguishing plastic housing, IP rating IP40 • Mounted on DIN-Rail TS 35 in accordance with EN 60715 • Mounting position any • Shockproof terminal connection according to VBG 4 (PZ1 required) • IP rating IP20 • Tightening torque max. 1Nm | | | | |
| Terminal capacity | 1 x 0,5 to 2,5mm ² with/without multicore cable end • 1 x 4mm ² without multicore cable end • 2 x 0,5 to 1,5mm ² with/without multicore cable end • 2 x 2,5mm ² flexible without multicore cable end | | | | |
| Ambient conditions | Ambient temperature: -25 to 55°C (in accordance with IEC 60068-1); -25 to 40°C (in accordance with UL 508) • Storage temperature: -25 to +70°C • Transport temperature: -25 to +70°C • relative humidity: 15% to 85% (in accordance with IEC 60721-3-3 class 3K3) • Pollution degree: 3 (in accordance with IEC 60664-1) • Vibration resistance: 10 to 55Hz 0,35mm (in accordance with IEC 60068-2-6) • Shock resistance: 15g 11ms (in accordance with IEC 60068-2-27) | | | | |
| Accessories | PowerModule TR2 (12 - 440V AC) • DC power supply SNT2 24V DC • sealable intervention protection shield FA-G2 | | | | |

Dimensions

| | |
|-----------|--|
| UNDER | Undervoltage monitoring |
| UNDER+SEQ | Undervoltage monitoring and monitoring of phase sequence |
| WIN | Monitoring the window between Min and Max |
| WIN+SEQ | Monitoring the window between Min and Max and monitoring of phase sequence |

G2PM with PowerModule 24V AC

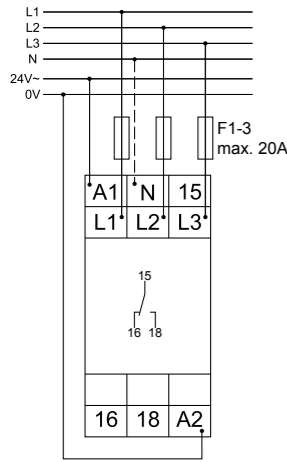

G2PM with PowerModule 230VAC

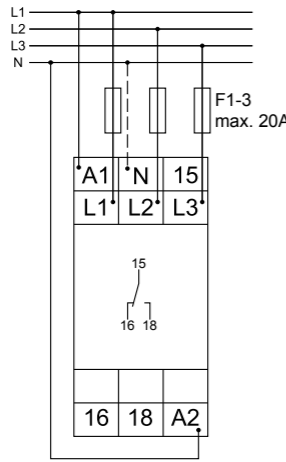

G2PM with PowerModule 400VAC

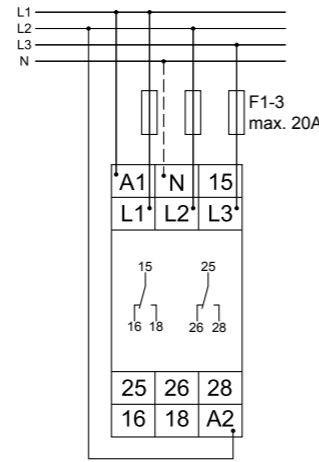

Width 22,5mm

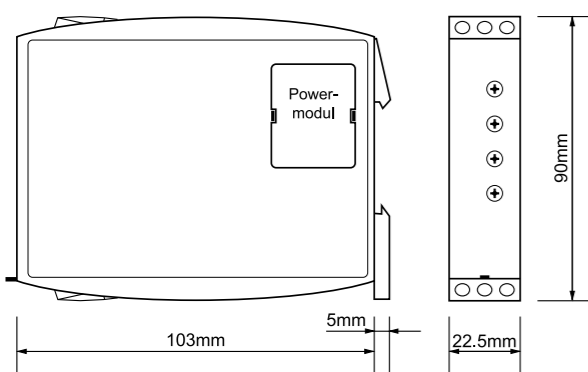

Functions



Sensing & Monitoring Relays Series GAMMA *WatchDog*



Voltage monitoring in 3-phase mains

- Multifunction (G2PM); Windowfunction
- Monitoring of phase sequence and phase failure
- Asymmetry detection switchable
- Connection of neutral wire optional
- Detection of loss of neutral wire
- Supply voltage selectable via PowerModules or by zoom voltage 24-240V
- 1 CO contact; 2 CO contacts
- Width 22,5mm
- Industrial design

Connections

types

G2PU690VS20

G2PU400VSY10
230V AC



Art.No. (PQ1)

2390507

2390511B

Art.No. (PQ10)

-

-

EAN13-Code

9008662006454

9008662006652

Measured variable

3~
AC Sinus (48 bis 63Hz)

3(N)~
AC Sinus (48 to 63Hz)

Measured range

208V to 690V
terminals L1-L2-L3

$U_N = 400/230V$
terminals (N)-L1-L2-L3

Controls

min • Delay

ASYM • max • min

Indicators (LEDs)

U • min • SEQ • R

ASYM • max • min • SEQ • R

Functions

UNDER+SEQ

UNDER+SEQ

Asymmetry

fixeded, 25%

5% to 25%

Switching threshold max.

-

-20% to +30% from U_N

Switching threshold min.

180V to 690V

-30% to +20% from U_N

Tripping delay

0,1s to 10s

-

Start-up suppression time

-

-

Fault latch

-

-

Supply

= measuring voltage
3~ 177V to 794V
Terminals L1-L2-L3

230V AC
terminals A1-A2

Output

2 CO contacts
250V, 5A AC

1 CO contact
250V, 5A AC

Width

22,5mm

22,5mm

Certificates

CE • GOST

CE • cULus • GOST

Mechanical design

Self-extinguishing plastic housing, IP rating IP40 • Mounted on DIN-Rail TS 35 in accordance with EN 60715 • Mounting position any • Shockproof terminal connection according to VBG 4 (PZ1 required) • IP rating IP20 • Tightening torque max. 1Nm

Terminal capacity

1 x 0,5 to 2,5mm² with/without multicore cable end • 1 x 4mm² without multicore cable end • 2 x 0,5 to 1,5mm² with/without multicore cable end • 2 x 2,5mm² flexible without multicore cable end

Ambient conditions

Ambient temperature: -25 to 55°C (in accordance with IEC 60068-1); -25 to 40°C (in accordance with UL 508) • Storage temperature: -25 to +70°C • Transport temperature: -25 to +70°C • relative humidity: 15% to 85% (in accordance with IEC 60721-3-3 class 3K3) • Pollution degree: 3 (in accordance with IEC 60664-1) • Vibration resistance: 10 to 55Hz 0,35mm (in accordance with IEC 60068-2-6) • Shock resistance: 15g 11ms (in accordance with IEC 60068-2-27)

Accessories

Sealable intervention protection shield FA-G2

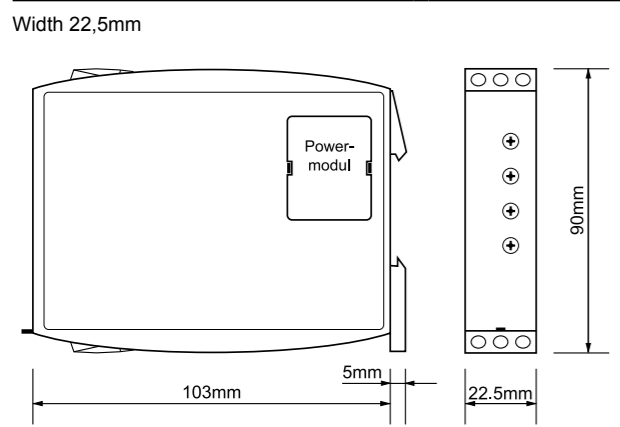
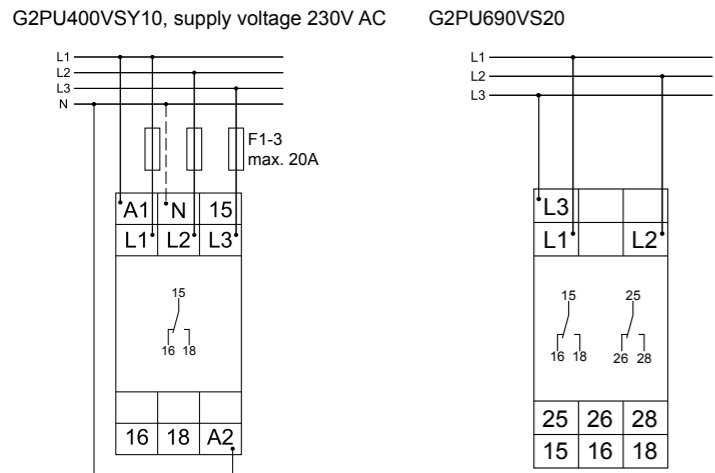

Functions



Sensing & Monitoring Relays Series GAMMA *WatchDog*



Voltage monitoring in 3-phase mains

- Multifunction
- Monitors phase to neutral voltages
- Connection of neutral wire necessary
- Fault latch
- Supply voltage selectable via PowerModules or DC power supply
- 2 CO contacts
- Width 22,5mm
- Industrial design

Connections

types

G2YM400VL20



Dimensions

| | |
|---------------------------|--|
| Art.No. (PQ1) | 2390508 |
| Art.No. (PQ10) | - |
| EAN13-Code | 900866200285 |
| Measured variable | 3N~ AC Sinus (16 to 400Hz) |
| Measured range | $U_N = 400/230V$ terminals N-L1-L2-L3 |
| Controls | max • min • Delay • Function |
| Indicators (LEDs) | U • max • min • R |
| Functions | OVER OVER+LATCH UNDER UNDER+LATCH WIN WIN+LATCH |
| Asymmetry | - |
| Switching threshold max. | -20% to 30% from U_N |
| Switching threshold min. | -30% to 20% from U_N |
| Tripping delay | 0,1s to 10s |
| Start-up suppression time | - |
| Fault latch | selectable |
| Supply | PowerModule TR2 or SNT2 terminals A1-A2 |
| Output | 2 CO contacts 250V, 5A AC |
| Width | 22,5mm |
| Certificates | CE • cULus • GOST |
| Mechanical design | Self-extinguishing plastic housing, IP rating IP40 • Mounted on DIN-Rail TS 35 in accordance with EN 60715 • Mounting position any • Shockproof terminal connection according to VBG 4 (PZ1 required) • IP rating IP20 • Tightening torque max. 1Nm |
| Terminal capacity | 1 x 0,5 to 2,5mm ² with/without multicore cable end • 1 x 4mm ² without multicore cable end • 2 x 0,5 to 1,5mm ² with/without multicore cable end • 2 x 2,5mm ² flexible without multicore cable end |
| Ambient conditions | Ambient temperature: -25 to 55°C (in accordance with IEC 60068-1); -25 to 40°C (in accordance with UL 508) • Storage temperature: -25 to +70°C • Transport temperature: -25 to +70°C • relative humidity: 15% to 85% (in accordance with IEC 60721-3-3 class 3K3) • Pollution degree: 3 (in accordance with IEC 60664-1) • Vibration resistance: 10 to 55Hz 0,35mm (in accordance with IEC 60068-2-6) • Shock resistance: 15g 11ms (in accordance with IEC 60068-2-27) |
| Accessories | PowerModulee TR2 (12 to 440V AC) • DC power supply SNT2 24V DC • sealable intervention protection shield FA-G2 |

| | |
|-------------|--|
| OVER | Overvoltage monitoring |
| OVER+Latch | Overvoltage monitoring with fault latch |
| UNDER | Undervoltage monitoring |
| UNDER+Latch | Undervoltage monitoring with fault latch |
| WIN | Monitoring the window between Min and Max |
| WIN+Latch | Monitoring the window between Min and Max with fault latch |

G2YM400VL20 with PowerModule 24V AC without fault latch

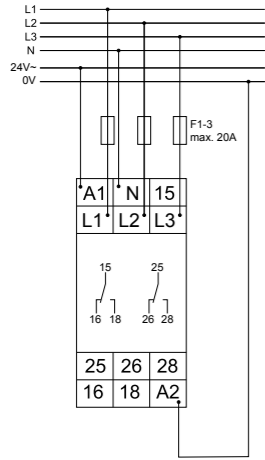

G2YM400VL20 with PowerModule 230V AC with fault latch

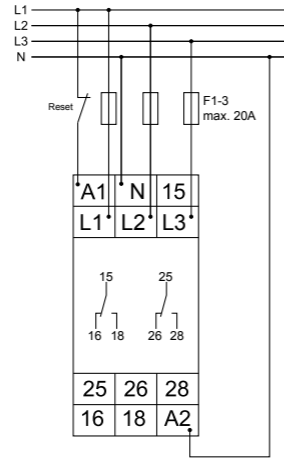

G2YM400VL20 with PowerModule 230V AC without fault latch

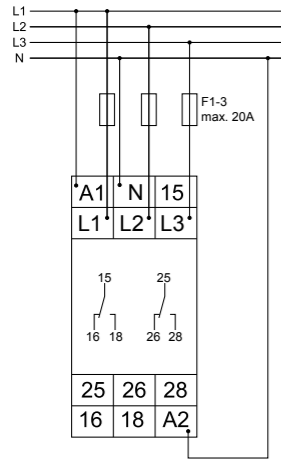

Width 22,5mm

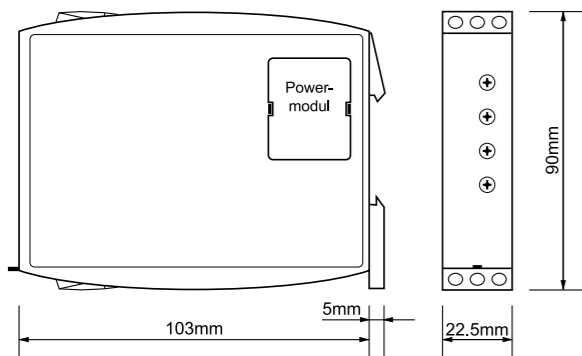

Functions



Sensing & Monitoring Relays Series GAMMA

WatchDog



Voltage monitoring in 3-phase mains

- Monitoring of phase sequence and phase failure
- Detection of reverse voltage
- Connection of neutral wire optional
- Supply voltage = measuring voltage
- 2 CO contacts
- Width 22,5mm
- Industrial design

Connections

types

G2PF400VS02

G2PF230VS02

G2PF115VS02



Art.No. (PQ1)

2390000

2390001

2390002

Art.No. (PQ10)

2390000B

-

-

EAN13-Code

900866200229

900866200232

900866200234

Measured variable

3(N)~
AC Sinus (48 to 63Hz)

3(N)~
AC Sinus (48 to 63Hz)

3(N)~
AC Sinus (48 to 63Hz)

Measured range

$U_N = 400/230V$
terminals (N)-L1-L2-L3

$U_N = 230/132V$
terminals (N)-L1-L2-L3

$U_N = 115/66V$
terminals (N)-L1-L2-L3

Controls

-

-

-

Indicators (LEDs)

U • R

U • R

U • R

Functions

Monitoring of phase sequence and phase failure

Monitoring of phase sequence and phase failure

Monitoring of phase sequence and phase failure

Asymmetry

fixed, typ. 30%

fixed, typ. 30%

fixed, typ. 30%

Switching threshold max.

-

-

-

Switching threshold min.

-

-

-

Tripping delay

fixed, max. 350ms

fixed, max. 350ms

fixed, max. 350ms

Start-up suppression time

fixed, max. 500ms

fixed, max. 500ms

fixed, max. 500ms

Fault latch

-

-

-

Supply

= measuring voltage
3(N)~ 342 to 457V
terminals (N)-L1-L2-L3

= measuring voltage
3(N)~ 198 to 264V
terminals (N)-L1-L2-L3

= measuring voltage
3(N)~ 99 to 132V
terminals (N)-L1-L2-L3

Output

2 CO contacts
250V, 5A AC

2 CO contacts
250V, 5A AC

2 CO contacts
250V, 5A AC

Dimensions

Width

22,5mm

22,5mm

22,5mm

Certificates

CE • cULus • GOST

CE • cULus • GOST

CE • cULus • GOST

Mechanical design

Self-extinguishing plastic housing, IP rating IP40 • Mounted on DIN-Rail TS 35 in accordance with EN 60715 • Mounting position any • Shockproof terminal connection according to VBG 4 (PZ1 required) • IP rating IP20 • Tightening torque max. 1Nm

Terminal capacity

1 x 0,5 to 2,5mm² with/without multicore cable end • 1 x 4mm² without multicore cable end • 2 x 0,5 to 1,5mm² with/without multicore cable end • 2 x 2,5mm² flexible without multicore cable end

Ambient conditions

Ambient temperature: -25 to 55°C (in accordance with IEC 60068-1); -25 to 40°C (in accordance with UL 508) • Storage temperature: -25 to +70°C • Transport temperature: -25 to +70°C • relative humidity: 15% to 85% (in accordance with IEC 60721-3-3 class 3K3) • Pollution degree: 3 (in accordance with IEC 60664-1) • Vibration resistance: 10 to 55Hz 0,35mm (in accordance with IEC 60068-2-6) • Shock resistance: 15g 11ms (in accordance with IEC 60068-2-27)

Accessories

-

G2PF...S02

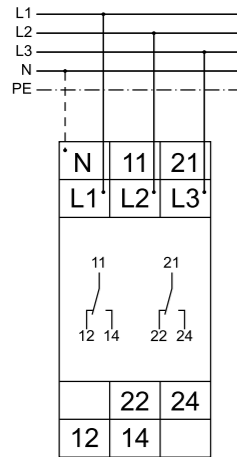

Width 22,5mm

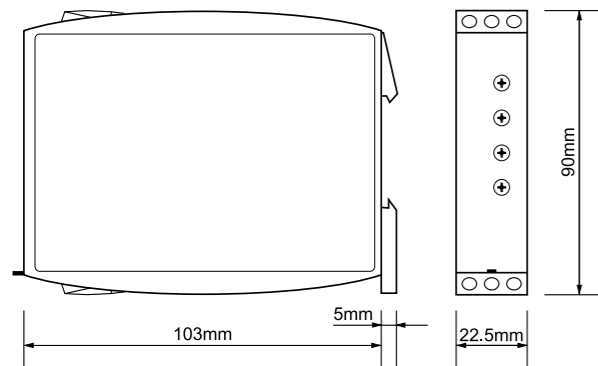

Functions



- Window function
- Measured voltage 110V to 400V
- Error memory
- Voltage breakdown detection
- Supply voltage 24 to 240V AC/DC
- 2 CO contacts
- Width 22,5mm
- Industrial design

Connections

types

G2FW400VL20 24-240V



Dimensions

| | |
|---------------------------|--|
| Art.No. (PQ1) | 2390900 |
| Art.No. (PQ10) | - |
| EAN13-Code | 9008662006607 |
| Measured variable | Frequency, 1-phase terminals F-E |
| Measured range | 110V to 400V terminals F-E |
| Controls | Start • max • min • Delay • Function |
| Indicators (LEDs) | U/t • max • min • UFailure • R |
| Functions | WIN |
| Switching threshold max. | F _N = 50Hz: 49, 49.5, 50, 50.5, 51, 52, 53.55, 57.5, 60Hz F _N = 60Hz: 59, 59.5, 60, 60.5, 61, 62, 63, 65, 67.5, 70Hz |
| Switching threshold min. | F _N = 50Hz: 40, 42.5, 45, 47, 48, 49, 49.5, 50, 50.5, 51Hz F _N = 60Hz: 50, 52.5, 55, 57, 58, 59, 59.5, 60, 60.5, 61Hz |
| Tripping delay | 0,1s to 10s |
| Start-up suppression time | 0s to 10s |
| Fault latch | - |
| Supply | 24 to 240V AC/DC terminals A1-A2 |
| Output | 2 CO contacts 250V, 5A AC |
| Width | 22,5mm |
| Certificates | CE |
| Mechanical design | Self-extinguishing plastic housing, IP rating IP40 • Mounted on DIN-Rail TS 35 in accordance with EN 60715 • Mounting position any • Shockproof terminal connection according to VBG 4 (PZ1 required) • IP rating IP20 • Tightening torque max. 1Nm |
| Terminal capacity | 1 x 0,5 to 2,5mm ² with/without multicore cable end • 1 x 4mm ² without multicore cable end • 2 x 0,5 to 1,5mm ² with/without multicore cable end • 2 x 2,5mm ² flexible without multicore cable end |
| Ambient conditions | Ambient temperature: -25 to 55°C (in accordance with IEC 60068-1); -25 to 40°C (in accordance with UL 508) • Storage temperature: -25 to +70°C • Transport temperature: -25 to +70°C • relative humidity: 15% to 85% (in accordance with IEC 60721-3-3 class 3K3) • Pollution degree: 3 (in accordance with IEC 60664-1) • Vibration resistance: 10 to 55Hz 0,35mm (in accordance with IEC 60068-2-6) • Shock resistance: 15g 11ms (in accordance with IEC 60068-2-27) |
| Accessories | PowerModule TR2 (12 to 440V AC) • DC power supply SNT2 24V DC • sealable intervention protection shield FA-G2 |

Sensing & Monitoring Relays Series GAMMA

WatchDog



Frequency monitoring for 50/60Hz networks

G2FW400VL20 24-240V:

Frequency monitoring for 50/60Hz supply with adjustable thresholds, separately adjustable on delay and trip delay.

50Hz:

WIN: Window monitoring, monitoring of range..., $F_N=50\text{Hz}$

WIN+Latch: Window monitoring with error memory, $F_N=50\text{Hz}$

60Hz:

WIN: Window monitoring, monitoring of range..., $F_N=60\text{Hz}$

WIN+Latch: Window monitoring with error memory, $F_N=60\text{Hz}$

G2FW400VL20, measured voltage = 400V AC (phase-phase)
supply voltage 24-240V AC/DC

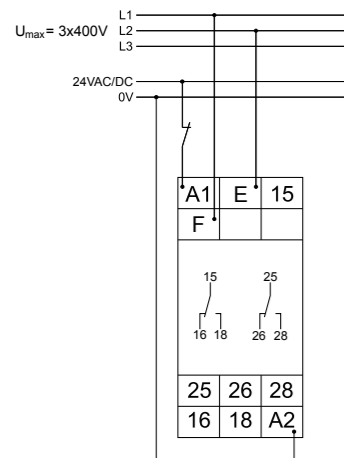

Width 22,5mm

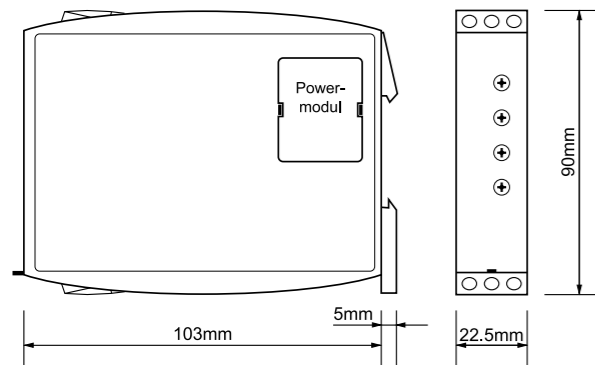

Functions



Sensing & Monitoring Relays Series **GAMMA**

WatchDog



Voltage monitoring in 1-phase mains

- Multifunction
- Frequency range 16,6 to 400Hz
- Fault latch
- Supply voltage selectable via PowerModules or by zoom voltage 24 to 240V AC/DC
- 1 CO contact; 2 CO contacts
- Width 22,5mm
- Industrial design

Connections

types

G2UM500VL10 230V

G2UM300VL20
24-240V AC

G2UM300VL20



Art.No. (PQ1)

2390306A

2390304

2390303

Art.No. (PQ10)

-

-

-

EAN13-Code

900866200262

900866200260

900866200259

Measured variable

Voltage AC/DC
AC Sinus (16,6 to 400Hz)

Voltage AC/DC
AC Sinus (16,6 to 400Hz)

Voltage AC/DC
AC Sinus (16,6 to 400Hz)

Measuring ranges

150V; terminals E-F1(+)
300V; terminals E-F2(+)
500V; terminals E-F3(+)

30V; terminals E-F1(+)
60V; terminals E-F2(+)
300V; terminals E-F3(+)

30V; terminals E-F1(+)
60V; terminals E-F2(+)
300V; terminals E-F3(+)

Controls

Start • max • min • Delay • Function

Start • max • min • Delay • Function

Start • max • min • Delay • Function

Indicators (LEDs)

U/t • max • min • R

U/t • max • min • R

U/t • max • min • R

Functions

OVER
OVER+LATCH
UNDER
UNDER+LATCH
WIN
WIN+LATCH

OVER
OVER+LATCH
UNDER
UNDER+LATCH
WIN
WIN+LATCH

OVER
OVER+LATCH
UNDER
UNDER+LATCH
WIN
WIN+LATCH

Switching threshold max.

10% to 100% from U_N

10% to 100% from U_N

10% to 100% from U_N

Switching threshold min.

5% to 95% from U_N

5% to 95% from U_N

5% to 95% from U_N

Tripping delay

0,1s to 10s

0,1s to 10s

0,1s to 10s

Start-up suppression time

0s to 10s

0s to 10s

0s to 10s

Fault latch

selectable

selectable

selectable

Supply

230V AC
terminals A1-A2

24 to 240V AC/DC
terminals A1-A2

PowerModule TR2 or
SNT2
terminals A1-A2

Output

1 CO contacts
250V, 5A AC

2 CO contacts
250V, 5A AC

2 CO contacts
250V, 5A AC

Width

22,5mm

22,5mm

22,5mm

Certificates

CE • cULus • GOST

CE • cULus • GOST

CE • cULus • GOST

Mechanical design

Self-extinguishing plastic housing, IP rating IP40 • Mounted on DIN-Rail TS 35 in accordance with EN 60715 • Mounting position any • Shockproof terminal connection according to VBG 4 (PZ1 required), IP rating IP20 • Tightening torque max. 1Nm

Terminal capacity

1 x 0,5 to 2,5mm² with/without multicore cable end • 1 x 4mm² without multicore cable end • 2 x 0,5 to 1,5mm² with/without multicore cable end • 2 x 2,5mm² flexible without multicore cable end

Ambient conditions

Ambient temperature: -25 to 55°C (in accordance with IEC 60068-1); -25 to 40°C (in accordance with UL 508) • Storage temperature: -25 to +70°C • Transport temperature: -25 to +70°C • relative humidity: 15% to 85% (in accordance with IEC 60721-3-3 class 3K3) • Pollution degree: 3 (in accordance with IEC 60664-1) • Vibration resistance: 10 to 55Hz 0,35mm (in accordance with IEC 60068-2-6) • Shock resistance: 15g 11ms (in accordance with IEC 60068-2-27)

Accessories

PowerModule TR2 (12 to 440V AC) • DC power supply SNT2 24V DC • sealable intervention protection shield FA-G2

Dimensions

Controls

Indicators (LEDs)

Functions

Switching threshold max.

Switching threshold min.

Tripping delay

Start-up suppression time

Fault latch

Supply

Output

Width

Certificates

Mechanical design

Terminal capacity

Ambient conditions

Accessories

OVER Overvoltage monitoring
 UNDER UNDERvoltage monitoring
 WIN Monitoring the window between Min and Max

OVER+Latch Overvoltage monitoring with fault latch
 UNDER+Latch UNDERvoltage monitoring with fault latch
 WIN+Latch Monitoring the window between Min and Max with fault latch

G2UM500VL10, measuring range: 300V
 supply voltage: 230V AC

G2UM300VL20, measuring range: 300V
 supply voltage: 24-240V AC/DC

G2UM300VL20, measuring range: 30V
 supply voltage: 24V AC

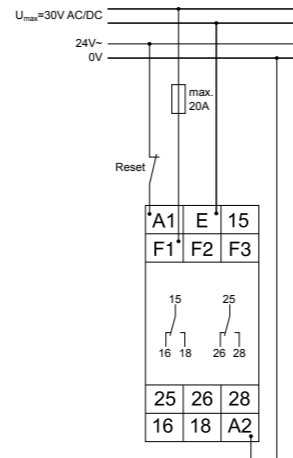
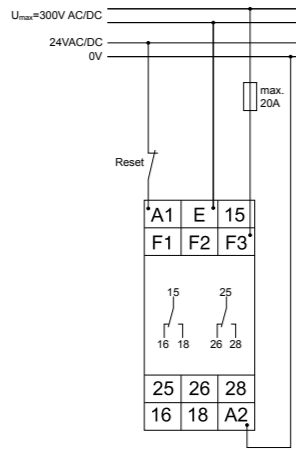
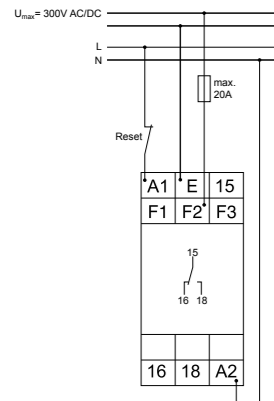

Width 22,5mm

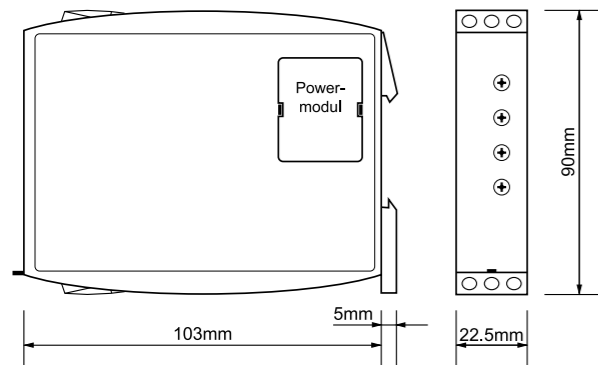

Functions



Sensing & Monitoring Relays Series GAMMA

WatchDog



Voltage monitoring in 1-phase mains

- Multifunction (G2UM); Windowfunction (G2UW)
- Frequency range 16,6 to 400Hz (G2UM)
- Fault latch (G2UM)
- Supply voltage selectable via PowerModules or by zoom voltage 24 to 240V AC/DC
- 1 CO contact; 2 CO contacts
- Width 22,5mm
- Industrial design

Connections

types

G2UM300VL10

G2UM10VL20
24-240V AC/DC

G2UW300V10



Art.No. (PQ1)

2390300

2390307

2390301

Art.No. (PQ10)

-

-

-

EAN13-Code

900866200256

9008662006089

900866200257

Measured variable

Voltage AC/DC
AC Sinus (16 to 400Hz)

Voltage AC/DC
AC Sinus (16 to 400Hz)

Voltage AC/DC
AC Sinus (48 to 63Hz)

Measuring ranges

30V; terminals E-F1(+)
60V; terminals E-F2(+)
300V; terminals E-F3(+)

60mV; terminals E-F1(+)
150mV; terminals E-F2(+)
10V; terminals E-F3(+)

30V; terminals E-F1(+)
60V; terminals E-F2(+)
300V; terminals E-F3(+)

Controls

Start • max • min • Delay • Function

Start • max • min • Delay • Function

max • min • Delay

Indicators (LEDs)

U/t • max • min • R

U/t • max • min • R

U • max • min • R

Functions

OVER
OVER+LATCH
UNDER
UNDER+LATCH
WIN
WIN+LATCH

OVER
OVER+LATCH
UNDER
UNDER+LATCH
WIN
WIN+LATCH

WIN

Switching threshold max.

10% to 100% from U_N

10% to 100% from U_N

10% to 100% from U_N

Switching threshold min.

5% to 95% from U_N

5% to 95% from U_N

5% to 95% from U_N

Tripping delay

0,1s to 10s

0,1s to 10s

0,2s to 10s

Start-up suppression time

0s to 10s

0s to 10s

-

Fault latch

wire link Y1-Y2

selectable

-

Supply

PowerModule TR2 or SNT2
terminals A1-A2

24 to 240V AC/DC
terminals A1-A2

PowerModule TR2 or SNT2
terminals A1-A2

Output

1 CO contact
250V, 5AAC

2 CO contacts
250V, 5AAC

1 CO contact
250V, 5AAC

Width

22,5mm

22,5mm

22,5mm

Certificates

CE • cULus • GOST

CE • cULus • GOST

CE • cULus • GOST

Mechanical design

Self-extinguishing plastic housing, IP rating IP40 • Mounted on DIN-Rail TS 35 in accordance with EN 60715 • Mounting position any • Shockproof terminal connection according to VBG 4 (PZ1 required), IP rating IP20 • Tightening torque max. 1Nm

Terminal capacity

1 x 0,5 to 2,5mm² with/without multicore cable end • 1 x 4mm² without multicore cable end • 2 x 0,5 to 1,5mm² with/without multicore cable end • 2 x 2,5mm² flexible without multicore cable end

Ambient conditions

Ambient temperature: -25 to 55°C (in accordance with IEC 60068-1); -25 to 40°C (in accordance with UL 508) • Storage temperature: -25 to +70°C • Transport temperature: -25 to +70°C • relative humidity: 15% to 85% (in accordance with IEC 60721-3-3 class 3K3) • Pollution degree: 3 (in accordance with IEC 60664-1) • Vibration resistance: 10 to 55Hz 0,35mm (in accordance with IEC 60068-2-6) • Shock resistance: 15g 11ms (in accordance with IEC 60068-2-27)

Accessories

PowerModule TR2 (12 to 440V AC) • DC power supply SNT2 24V DC • sealable intervention protection shield FA-G2

Dimensions

OVER Overvoltage monitoring
 UNDER UNDERvoltage monitoring
 WIN Monitoring the window between Min and Max

G2UM

Fault latch via wire link Y1-Y2 selectable
 OVER+Latch Overvoltage monitoring with fault latch
 UNDER+Latch UNDERvoltage monitoring with fault latch
 WIN+Latch Monitoring the window between Min and Max with fault latch

G2UM300VL10, measuring range 60V AC/DC, supply voltage: 230V AC
 G2UW300V10, measuring range 30V AC/DC, supply voltage: 24V AC
 G2UM10VL20, measuring range: 60mV AC/DC, supply voltage: 24V AC/DC

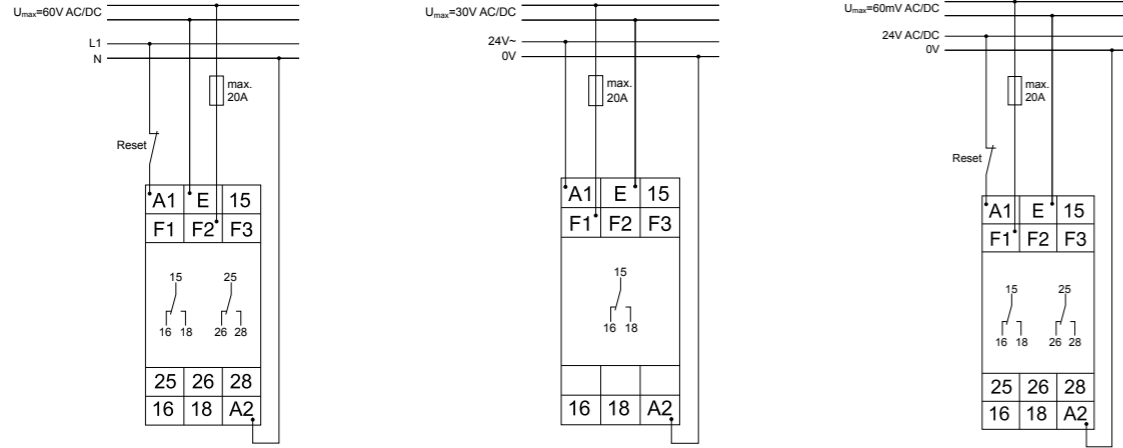

Width 22,5mm

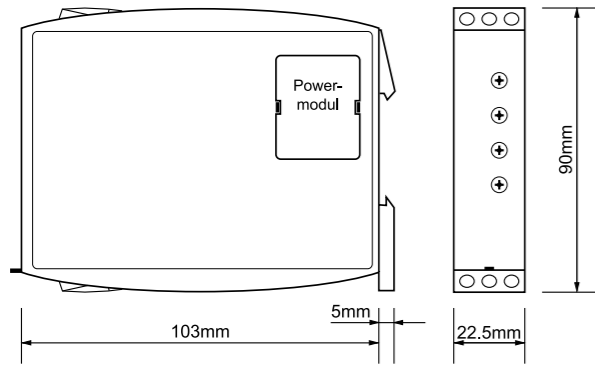

Functions



Sensing & Monitoring Relays Series GAMMA

WatchDog



Current monitoring in 1-phase mains

- Multifunction
- Frequency range 16,6 to 400Hz
- Fault latch
- Supply voltage selectable via PowerModules or by zoom voltage 24 to 240V AC/DC
- 1 CO contact; 2 CO contacts
- Width 22,5mm
- Industrial design

Connections

types

G2IM10AL20
24-240V

G2IM10AL20

G2IM10AL10

G2IM5AL20
24-240V

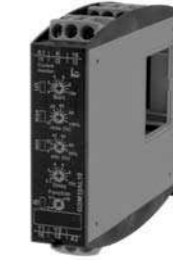

Art.No. (PQ1)

Art.No. (PQ10)

EAN13-Code

Measured variable

Measuring ranges

Controls

Indicators (LEDs)

Functions

Switching threshold max.

Switching threshold min.

Tripping delay

Start-up suppression time

Fault latch

Supply

Output

Width

Certificates

Mechanical design

Terminal capacity

Ambient conditions

Accessories

| | G2IM10AL20 24-240V | G2IM10AL20 | G2IM10AL10 | G2IM5AL20 24-240V |
|---------------------------|---|---|---|---|
| Art.No. (PQ1) | 2390410 | 2390406 | 2390400 | 2390411 |
| Art.No. (PQ10) | - | - | - | - |
| EAN13-Code | 900866200273 | 900866200269 | 900866200263 | 900866200274 |
| Measured variable | Current AC/DC AC Sinus (16,6 to 400Hz) | Current AC/DC AC Sinus (16,6 to 400Hz) | Current AC/DC AC Sinus (16,6 to 400Hz) | Current AC/DC AC Sinus (16,6 to 400Hz) |
| Measuring ranges | 100mA AC/DC; terminals K-11(+) 1A AC/DC; terminals K-12(+) 10A AC/DC; terminals K-13(+) | 100mA AC/DC; terminals K-11(+) 1A AC/DC; terminals K-12(+) 10A AC/DC; terminals K-13(+) | 100mA AC/DC; terminals K-11(+) 1A AC/DC; terminals K-12(+) 10A AC/DC; terminals K-13(+) | 20mA AC/DC; terminals K-11(+) 1A AC/DC; terminals K-12(+) 5A AC/DC; terminals K-13(+) |
| Controls | Start • max • min • Delay • Function | Start • max • min • Delay • Function | Start • max • min • Delay • Function | Start • max • min • Delay • Function |
| Indicators (LEDs) | U/t • max • min • R | U/t • max • min • R | U/t • max • min • R | U/t • max • min • R |
| Functions | OVER OVER+LATCH UNDER UNDER+LATCH WIN WIN+LATCH | OVER OVER+LATCH UNDER UNDER+LATCH WIN WIN+LATCH | OVER OVER+LATCH UNDER UNDER + Latch WIN WIN+Latch | OVER OVER+LATCH UNDER UNDER+LATCH WIN WIN+LATCH |
| Switching threshold max. | 10% to 100% from I _N | 10% to 100% from I _N | 10% to 100% from I _N | 10% to 100% from I _N |
| Switching threshold min. | 5% to 95% from I _N | 5% to 95% from I _N | 5% to 95% from I _N | 5% to 95% from I _N |
| Tripping delay | 0,1s to 10s | 0,1s to 10s | 0,1s to 10s | 0,1s to 10s |
| Start-up suppression time | 0s to 10s | 0s to 10s | 0s to 10s | 0s to 10s |
| Fault latch | selectable | selectable | selectable | selectable |
| Supply | 24 to 240V terminals A1-A2 | PowerModule TR2 or SNT2 terminals A1-A2 | PowerModule TR2 or SNT2 terminals A1-A2 | 24 to 240V terminals A1-A2 |
| Output | 2 CO contacts 250V, 5A AC | 2 CO contacts 250V, 5A AC | 1 CO contact 250V, 5A AC | 2 CO contacts 250V, 5A AC |
| Width | 22,5mm | 22,5mm | 22,5mm | 22,5mm |
| Certificates | CE • cULus • GOST | CE • cULus • GOST | CE • cULus • GOST | CE • cULus • GOST |

Self-extinguishing plastic housing, IP rating IP40 • Mounted on DIN-Rail TS 35 in accordance with EN 60715 • Mounting position any • Shockproof terminal connection according to VBG 4 (PZ1 required) • IP rating IP20 • Tightening torque max. 1Nm

1 x 0,5 to 2,5mm² with/without multicore cable end • 1 x 4mm² without multicore cable end • 2 x 0,5 to 1,5mm² with/without multicore cable end • 2 x 2,5mm² flexible without multicore cable end

Ambient temperature: -25 to 55°C (in accordance with IEC 60068-1); -25 to 40°C (in accordance with UL 508) • Storage temperature: -25 to +70°C • Transport temperature: -25 to +70°C • relative humidity: 15% to 85% (in accordance with IEC 60721-3-3 class 3K3) • Pollution degree: 3 (in accordance with IEC 60664-1) • Vibration resistance: 10 to 55Hz 0,35mm (in accordance with IEC 60068-2-6) • Shock resistance: 15g 11ms (in accordance with IEC 60068-2-27)

PowerModulee TR2 (12 to 440V AC) • DC power supply SNT2 24V DC • Current Transformers Series DSW and WSW • sealable intervention protection shield FA-G2

OVER Overcurrent monitoring
 UNDER Undercurrent monitoring
 WIN Monitoring the window between Min and Max

OVER+Latch Overcurrent monitoring with fault latch
 UNDER+Latch Undercurrent monitoring with fault latch
 WIN+Latch Monitoring the window between Min and Max with fault latch

Measured range 100mA AC/DC,
 supply voltage: 24V AC/DC

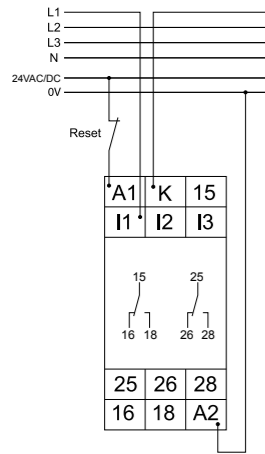

Measured range 1A AC/DC with
 Powermodule 230V AC

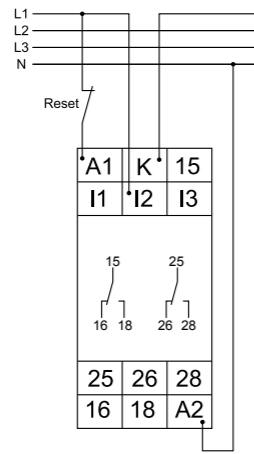

Measured range 5A AC/DC,
 supply voltage: 24V AC/DC

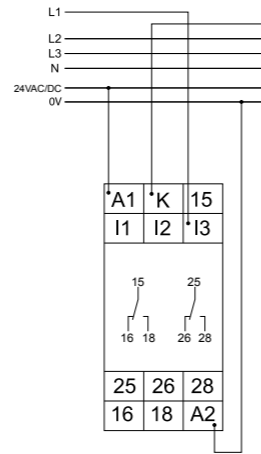

Width 22,5mm

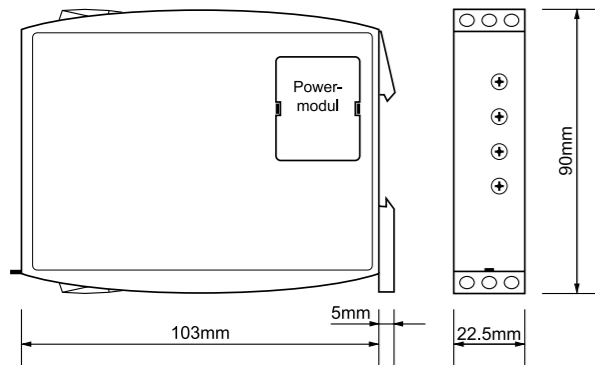

Functions



Sensing & Monitoring Relays Series GAMMA

WatchDog



Current monitoring in 1-phase mains

- Multifunction
- Frequency range 16,6 to 400Hz
- Fault latch
- Supply voltage selectable via PowerModules or by zoom voltage 24-240V
- 1 CO contact; 2 CO contacts
- Width 22,5mm
- Industrial design

Connections

G2IM10AL20 24-240V
 G2IM10AL20
 G2IM5AL20 24-240V

types

G2IM5AL20

G2IM5AL10

G2IM2AL20 24-240V



Art.No. (PQ1)

2390405

2390401

2390417

Art.No. (PQ10)

-

-

-

EAN13-Code

900866200268

900866200264

9008662006164

Measured variable

Current AC/DC AC Sinus (16,6 to 400Hz)

Current AC/DC
 AC Sinus (16,6 to 400Hz)

Current AC/DC
 AC Sinus (16,6 to 400Hz)

Measuring ranges

20mA AC/DC; terminals K-I1(+)
 1A AC/DC; terminals K-I2(+)
 5A AC/DC; terminals K-I3(+)

20mA AC/DC; terminals K-I1(+)
 1A AC/DC; terminals K-I2(+)
 5A AC/DC; terminals K-I3(+)

800mA AC/DC; terminals K-I1(+)
 1,5A AC/DC; terminals K-I2(+)
 2A AC/DC; terminals K-I3(+)

Controls

Start • max • min • Delay • Function

Start • max • min • Delay • Function

Start • max • min • Delay • Function

Indicators (LEDs)

U/t • max • min • R

U/t • max • min • R

U/t • max • min • R

Functions

OVER
 OVER+LATCH
 UNDER
 UNDER+LATCH
 WIN
 WIN+LATCH

OVER
 OVER+LATCH
 UNDER
 UNDER + Latch
 WIN
 WIN+LATCH

OVER
 OVER+LATCH
 UNDER
 UNDER + Latch
 WIN
 WIN+LATCH

Switching threshold max.

10% to 100% from I_N

10% to 100% from I_N

30% to 100% from I_N

Switching threshold min.

5% to 95% from I_N

5% to 95% from I_N

25% to 95% from I_N

Tripping delay

0,1s to 10s

0,1s to 10s

0,1s to 10s

Start-up suppression time

0s to 10s

0s to 10s

0s to 10s

Fault latch

selectable

selectable

selectable

Supply

PowerModule TR2 or SNT2
 terminals A1-A2

PowerModule TR2 or SNT2
 terminals A1-A2

24-240V
 terminals A1-A2

Output

2 CO contacts 250V, 5AAC

1 CO contact
 250V, 5AAC

1 CO contact
 250V, 5AAC

Width

22,5mm

22,5mm

22,5mm

Certificates

CE • cULus • GOST

CE • cULus • GOST

CE • cULus • GOST

Mechanical design

Self-extinguishing plastic housing, IP rating IP40 • Mounted on DIN-Rail TS 35 in accordance with EN 60715 • Mounting position any • Shockproof terminal connection according to VBG 4 (PZ1 required) • IP rating IP20 • Tightening torque max. 1Nm

Terminal capacity

1 x 0,5 to 2,5mm² with/without multicore cable end • 1 x 4mm² without multicore cable end • 2 x 0,5 to 1,5mm² with/without multicore cable end • 2 x 2,5mm² flexible without multicore cable end

Ambient conditions

Ambient temperature: -25 to 55°C (in accordance with IEC 60068-1); -25 to 40°C (in accordance with UL 508) • Storage temperature: -25 to +70°C • Transport temperature: -25 to +70°C • relative humidity: 15% to 85% (in accordance with IEC 60721-3-3 class 3K3) • Pollution degree: 3 (in accordance with IEC 60664-1) • Vibration resistance: 10 to 55Hz 0,35mm (in accordance with IEC 60068-2-6) • Shock resistance: 15g 11ms (in accordance with IEC 60068-2-27)

Accessories

PowerModule TR2 (12 to 440V AC) • DC power supply SNT2 24V DC • Current Transformers Series DSW and WSW • sealable intervention protection shield FA-G2

OVER Overcurrent monitoring
 UNDER Undercurrent monitoring
 WIN Monitoring the window between Min and Max

OVER+Latch Overcurrent monitoring with fault latch
 UNDER+Latch Undercurrent monitoring with fault latch
 WIN+Latch Monitoring the window between Min and Max with fault latch

Measuring range 20mA AC/DC, supply voltage: 24V AC/DC

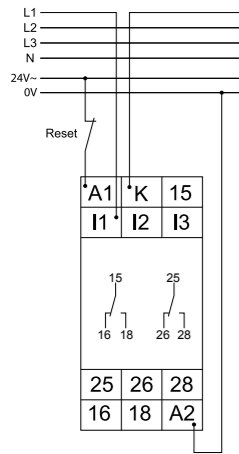

Measuring range 5A AC/DC with Powermodule 400V AC

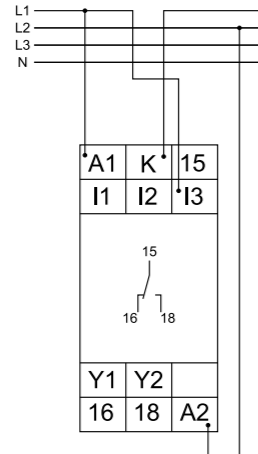

Measuring range 2A AC/DC, supply voltage: 24V AC/DC

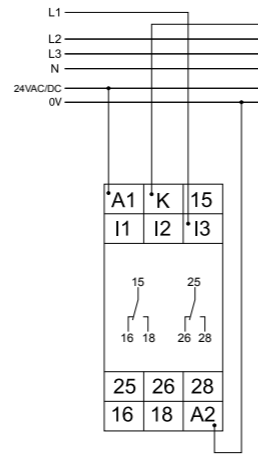

Width 22.5mm

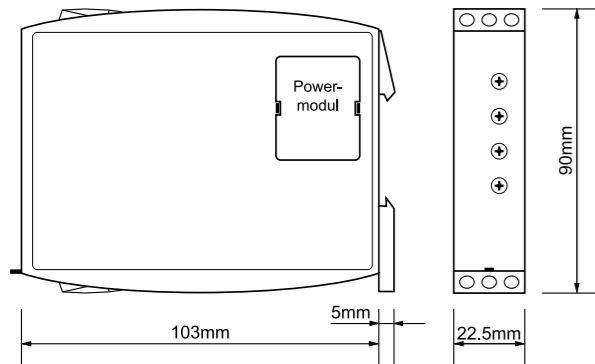

Functions



Sensing & Monitoring Relays Series GAMMA

WatchDog



Current monitoring in 1-phase mains

- Overcurrent monitoring (G2IO)
- UNDERcurrent monitoring (G2IU)
- Supply voltage via PowerModules or DC power supply
- 1 CO contact
- Width 22,5mm
- Industrial design

Connections

G2IM5AL20
 G2IM5AL10
 G2IM2AL20 24-240V

types

G2IO10A10

G2IO5A10

G2IU10A10

G2IU5A10

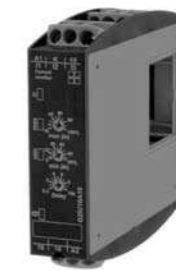
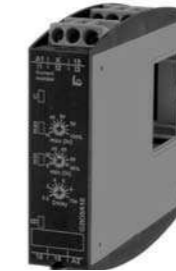
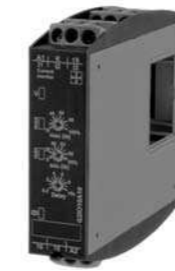

Art.No. (PQ1)

2390408

2390403

2390409

2390404

Art.No. (PQ10)

-

-

-

-

EAN13-Code

900866200271

900866200266

900866200272

900866200267

Measured variable

Current AC/DC
 AC Sinus (48 to 63Hz)

Current AC/DCAC Sinus (48 to 63Hz)

Current AC/DC
 AC Sinus (48 to 63Hz)

Current AC/DC
 AC Sinus (48 to 63Hz)

Measuring ranges

100mA AC/DC; terminals K-I1(+)
 1A AC/DC; terminals K-I2(+)
 10A AC/DC; terminals K-I3(+)

20mA AC/DC; terminals K-I1(+)
 1A AC/DC; terminals K-I2(+)
 5A AC/DC; terminals K-I3(+)

100mA AC/DC; terminals K-I1(+)
 1A AC/DC; terminals K-I2(+)
 10A AC/DC; terminals K-I3(+)

20mA AC/DC; terminals K-I1(+)
 1A AC/DC; terminals K-I2(+)
 5A AC/DC; terminals K-I3(+)

Controls

max • min • Delay

max • min • Delay

max • min • Delay

max • min • Delay

Indicators (LEDs)

U • max • min • R

U • max • min • R

U • max • min • R

U • max • min • R

Functions

OVER

OVER

UNDER

UNDER

Switching threshold max.

10% to 100% from I_N

10% to 100% from I_N

10% to 100% from I_N

10% to 100% from I_N

Switching threshold min.

5% to 95% from I_N

5% to 95% from I_N

5% to 95% from I_N

5% to 95% from I_N

Tripping delay

0,2s to 10s

0,2s to 10s

0,2s to 10s

0,2s to 10s

Start-up suppression time

-

-

-

-

Fault latch

-

-

-

-

Supply

PowerModule TR2 or SNT2
 terminals A1-A2

PowerModule TR2 or SNT2
 terminals A1-A2

PowerModule TR2 or SNT2
 terminals A1-A2

PowerModule TR2 or SNT2
 terminals A1-A2

Output

1 CO contact
 250V, 5A AC

1 CO contact
 250V, 5A AC

1 CO contact
 250V, 5A AC

1 CO contact
 250V, 5A AC

Width

22,5mm

22,5mm

22,5mm

22,5mm

Certificates

CE • cULus • GOST

CE • cULus • GOST

CE • cULus • GOST

CE • cULus • GOST

Mechanical design

Self-extinguishing plastic housing, IP rating IP40 • Mounted on DIN-Rail TS 35 in accordance with EN 60715 • Mounting position any • Shockproof terminal connection according to VBG 4 (PZ1 required) • IP rating IP20 • Tightening torque max. 1Nm

Terminal capacity

1 x 0,5 to 2,5mm² with/without multicore cable end • 1 x 4mm² without multicore cable end • 2 x 0,5 to 1,5mm² with/without multicore cable end • 2 x 2,5mm² flexible without multicore cable end

Ambient conditions

Ambient temperature: -25 to 55°C (in accordance with IEC 60068-1); -25 to 40°C (in accordance with UL 508) • Storage temperature: -25 to +70°C • Transport temperature: -25 to +70°C • relative humidity: 15% to 85% (in accordance with IEC 60721-3-3 class 3K3) • Pollution degree: 3 (in accordance with IEC 60664-1) • Vibration resistance: 10 to 55Hz 0,35mm (in accordance with IEC 60068-2-6) • Shock resistance: 15g 11ms (in accordance with IEC 60068-2-27)

Accessories

PowerModules TR2 (12 to 440V AC) • DC power supply SNT2 24V DC • Current Transformers Series DSW and WSW • sealable intervention protection shield FA-G2

Dimensions

OVER
UNDER

Overcurrent monitoring
Undercurrent monitoring

Measured range 20mA with Powermodule 24V AC

Measured range 1A with Powermodule 230V AC

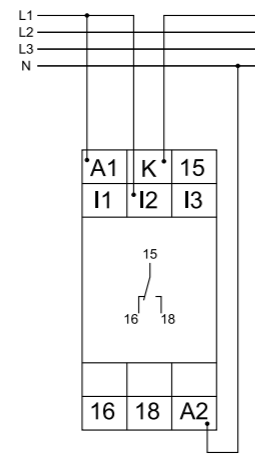
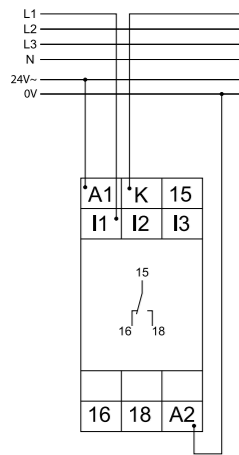

Width 22,5mm

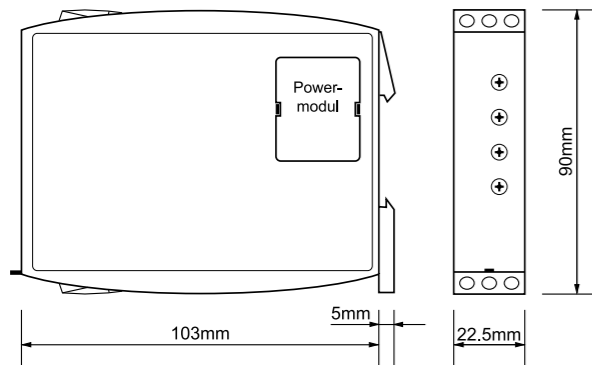

Functions



Sensing & Monitoring Relays Series GAMMA
Current monitoring in 3-phase mains

WatchDog



- Multifunction
- Fault latch
- Supply voltage selectable via PowerModules or by zoom voltage 24 to 240V AC/DC
- 2 CO contacts
- Width 22,5mm
- Industrial design

Connections

G2IO5A10
G2IU5A10
G2IO10A10
G2IU10A10

types

G2JM5AL20 24-240V

G2JM5AL20



Art.No. (PQ1)

2390801

2390800

Art.No. (PQ10)

-

-

EAN13-Code

900866200294

900866200293

Measured variable

Current 3~
AC Sinus (48 to 63Hz)

Current 3~
AC Sinus (48 to 63Hz)

Measured range

5A AC
terminals K-I1, K-I2, K-I3

5A AC
terminals K-I1, K-I2, K-I3

Controls

Start • max • min • Delay • Function

Start • max • min • Delay • Function

Indicators (LEDs)

U/t • max • min • R

U/t • max • min • R

Functions

OVER
OVER+LATCH
UNDER
UNDER+LATCH
WIN
WIN+LATCH

OVER
OVER+LATCH
UNDER
UNDER+LATCH
WIN
WIN+LATCH

Switching threshold max.

10% to 100% from I_N

10% to 100% from I_N

Switching threshold min.

5% to 95% from I_N

5% to 95% from I_N

Tripping delay

0,1s to 10s

0,1s to 10s

Start-up suppression time

0s to 10s

0s to 10s

Fault latch

selectable

selectable

Supply

24 to 240V AC/DC
terminals A1-A2

PowerModule TR2 or SNT2
terminals A1-A2

Output

2 CO contacts
250V, 5A AC

2 CO contacts
250V, 5A AC

Width

22,5mm

22,5mm

Certificates

CE • cULus • GOST

CE • cULus • GOST

Mechanical design

Self-extinguishing plastic housing, IP rating IP40 • Mounted on DIN-Rail TS 35 in accordance with EN 60715 • Mounting position any • Shockproof terminal connection according to VBG 4 (PZ1 required) • IP rating IP20 • Tightening torque max. 1Nm

Terminal capacity

1 x 0,5 to 2,5mm² with/without multicore cable end • 1 x 4mm² without multicore cable end • 2 x 0,5 to 1,5mm² with/without multicore cable end • 2 x 2,5mm² flexible without multicore cable end

Ambient conditions

Ambient temperature: -25 to 55°C (in accordance with IEC 60068-1); -25 to 40°C (in accordance with UL 508) • Storage temperature: -25 to +70°C • Transport temperature: -25 to +70°C • relative humidity: 15% to 85% (in accordance with IEC 60721-3-3 class 3K3) • Pollution degree: 3 (in accordance with IEC 60664-1) • Vibration resistance: 10 to 55Hz 0,35mm (in accordance with IEC 60068-2-6) • Shock resistance: 15g 11ms (in accordance with IEC 60068-2-27)

Accessories

PowerModulees TR2 (12 to 440V AC) • DC power supply SNT2 24V DC • Current Transformers Series DSW and WSW • sealable intervention protection shield FA-G2

| | |
|-------------|--|
| OVER | Overcurrent monitoring |
| OVER+LATCH | Overcurrent monitoring with fault latch |
| UNDER | Undercurrent monitoring |
| UNDER+LATCH | Undercurrent monitoring with fault latch |
| WIN | Monitoring the window between Min and Max |
| WIN+LATCH | Monitoring the window between Min and Max with fault latch |

G2JM5AL20, Supply 230V AC and Current Transformers

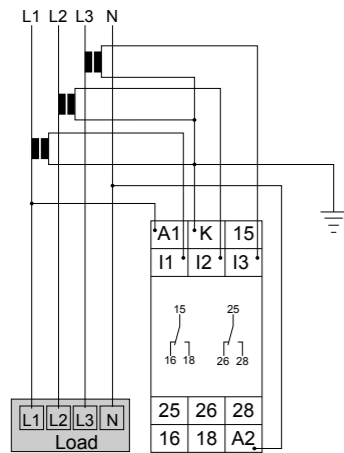

G2JM5AL20, Supply 24-240V AC/DC without fault latch

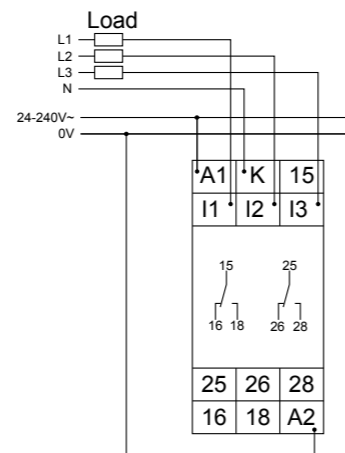

G2JM5AL20, Supply 230V AC and fault latch

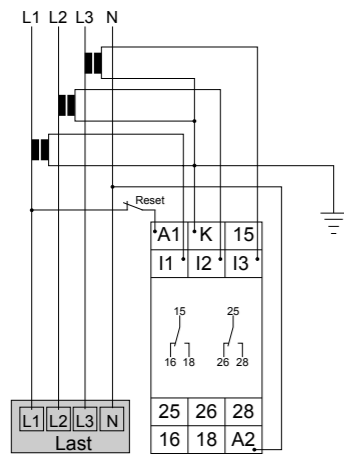

Width 22,5mm

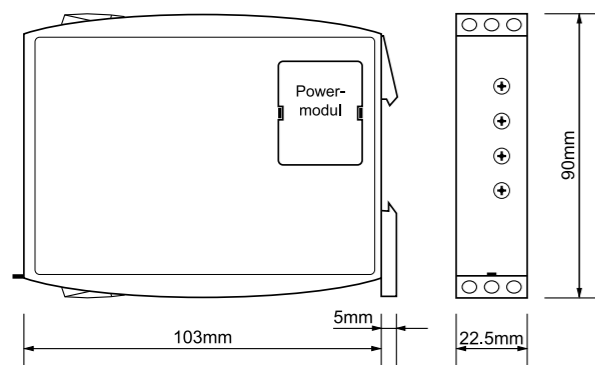

Functions



Sensing & Monitoring Relays Series GAMMA



Temperature monitoring

- Temperature monitoring by PT100 probes (2- and 3-wire connection)
- Multifunction
- Monitoring of short circuit or line break of sensor line
- Fault latch
- Supply voltage by zoom voltage 24 to 240V AC/DC
- 2 CO contacts
- Width 22,5mm
- Industrial design

Connections

types

G2TMPT100L20 24-240V



Art.No. (PQ1)

2390904

Art.No. (PQ10)

-

EAN13-Code

900866200295

Measured variable

Temperature monitoring PT100
2- and 3-wire connection

Measured range

-50°C to +200°C
terminals T1-T2-T3

Controls

Start • max • min • Offset • Function

Indicators (LEDs)

U/t • max • min • Sense • R

Functions

OVER
OVER+LATCH
UNDER
UNDER+LATCH
WIN
WIN+LATCH

Switching threshold max.

-45°C to +200°C

Switching threshold min.

-50°C to 195°C

Tripping delay

-

Start-up suppression time

0min to 30min

Fault latch

selectable

Supply

24 to 240V AC/DC
terminals A1-A2

Output

2 CO contacts
250V, 5A AC

Width

22,5mm

Certificates

CE • cULus • GOST

Mechanical design

Self-extinguishing plastic housing, IP rating IP40 • Mounted on DIN-Rail TS 35 in accordance with EN 60715 • Mounting position any • Shockproof terminal connection according to VBG 4 (PZ1 required), IP rating IP20 • Tightening torque max. 1Nm

Terminal capacity

1 x 0,5 to 2,5mm² with/without multicore cable end • 1 x 4mm² without multicore cable end • 2 x 0,5 to 1,5mm² with/without multicore cable end • 2 x 2,5mm² flexible without multicore cable end

Ambient conditions

Ambient temperature: -25 to 55°C (in accordance with IEC 60068-1); -25 to 40°C (in accordance with UL 508) • Storage temperature: -25 to +70°C • Transport temperature: -25 to +70°C • relative humidity: 15% to 85% (in accordance with IEC 60721-3-3 class 3K3) • Pollution degree: 3 (in accordance with IEC 60664-1) • Vibration resistance: 10 to 55Hz 0,35mm (in accordance with IEC 60068-2-6) • Shock resistance: 15g 11ms (in accordance with IEC 60068-2-27)

Accessories

Sealable intervention protection shield FA-G2

Connections

Dimensions

| | |
|-------------|--|
| OVER | Monitoring of overtemperature |
| OVER+LATCH | Monitoring of overtemperature with fault latch |
| UNDER | Monitoring of undertemperature |
| UNDER+LATCH | Monitoring of undertemperature with fault latch |
| WIN | Monitoring the window between Min and Max |
| WIN+LATCH | Monitoring the window between Min and Max with fault latch |

2-wire connection, Supply 24V AC/DC and fault latch

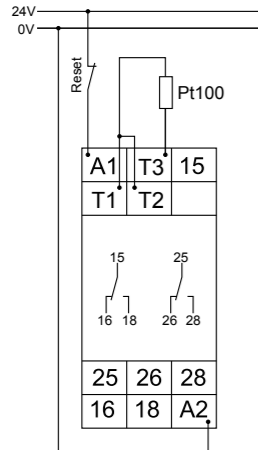

3-wire connection, Supply 230V AC without fault latch

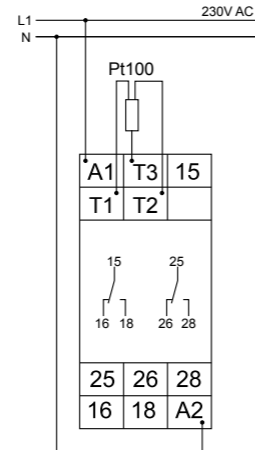

Width 22,5mm

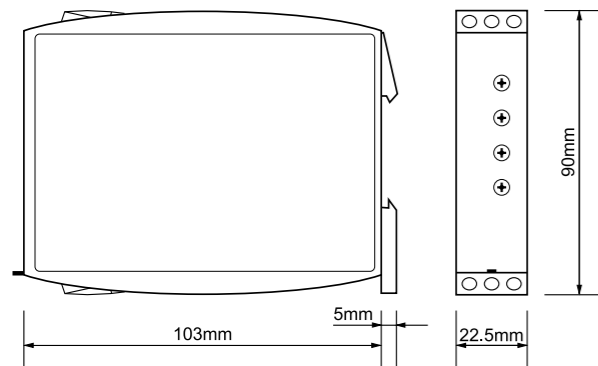

Functions



Sensing & Monitoring Relays Series GAMMA



Temperature monitoring

- Temperature monitoring of the motor winding in accordance with DIN 44081
- Maximal 6 PTC probes
- Fault latch
- Short circuit monitoring of the PTC Input (G2TFKN02)
- Testfunction with integrated Test/Reset button; possibility for external reset
- Supply voltage selectable via PowerModules or by zoom voltage 24 to 240VAC/DC
- 1 CO contact; 2 CO contacts
- Width 22,5mm
- Industrial design

Connections

types

G2TFKN02
24-240V

G2TFKN02

G2TF02 24-240V

G2TF02



Art.No. (PQ1)

2390110

2390101

2390111

2390100

Art.No. (PQ10)

-

-

-

-

EAN13-Code

900866200251

900866200237

900866200252

900866200236

Measured variable

PTC (motortemperature)
max. 6 PTC probes

PTC (motortemperature)
max. 6 PTC probes

PTC (motortemperature)
max. 6 PTC probes

PTC (motortemperature)
max. 6 PTC probes

Measured range

total resistance cold <1,5kΩ
terminals T1-T2

total resistance cold <1,5kΩ
terminals T1-T2

total resistance cold <1,5kΩ
terminals T1-T2

total resistance cold <1,5kΩ
terminals T1-T2

Measuring voltage

≤2,5V DC at R ≤4,0kΩ
(DIN VDE 0660 part 302)

≤2,5V DC at R ≤4,0kΩ
(DIN VDE 0660 part 302)

≤2,5V DC at R ≤4,0kΩ
(DIN VDE 0660 part 302)

≤2,5V DC at R ≤4,0kΩ
(DIN VDE 0660 part 302)

Controls

Test/Reset button • Function

Test/Reset button • Function

Test/Reset button

Test/Reset button

Indicators (LEDs)

U • Failure • R

U • Failure • R

U • Failure

U • Failure

Functions

Overtemperature
selectable functions:
+K (short circuit monitoring)
+N (remanent latch function)
+K+N (short circuit monitoring
and remanent latch function)

Overtemperature
selectable functions:
+K (short circuit monitoring)
+N (remanent latch function)
+K+N (short circuit monitoring
and remanent latch function)

Overtemperature

Overtemperature

Response value

3,6kΩ

3,6kΩ

3,6kΩ

3,6kΩ

Release value

1,8kΩ

1,8kΩ

1,8kΩ

1,8kΩ

Short circuit monitoring

<20Ω

<20Ω

-

-

Fault latch

yes (auto)

yes (auto)

yes (auto)

yes (auto)

Reset

internal or external
terminals R-T2

internal or external
terminals R-T2

internal or external
terminals R-T2

internal or external
terminals R-T2

Supply

24 to 240V AC/DC
terminals A1-A2

PowerModule TR2 or SNT2
terminals A1-A2

24-240V AC/DC
terminals A1-A2

PowerModule TR2 or SNT2
terminals A1-A2

Output

2 CO contacts
250V, 5A AC

2 CO contacts
250V, 5A AC

2 CO contacts
250V, 5A AC

2 CO contacts
250V, 5A AC

Width

22,5mm

22,5mm

22,5mm

22,5mm

Certificates

CE • cULus • GOST

CE • cULus • GOST

CE • cULus • GOST

CE • cULus • GOST

Mechanical design

Self-extinguishing plastic housing, IP rating IP40 • Mounted on DIN-Rail TS 35 in accordance with EN 60715 • Mounting position any • Shockproof terminal connection according to VBG 4 (PZ1 required) • IP rating IP20 • Tightening torque max. 1Nm

Terminal capacity

1 x 0,5 to 2,5mm² with/without multicore cable end • 1 x 4mm² without multicore cable end • 2 x 0,5 to 1,5mm² with/without multicore cable end • 2 x 2,5mm² flexible without multicore cable end

Ambient conditions

Ambient temperature: -25 to 55°C (in accordance with IEC 60068-1); -25 to 40°C (in accordance with UL 508) • Storage temperature: -25 to +70°C • Transport temperature: -25 to +70°C • relative humidity: 15% to 85% (in accordance with IEC 60721-3-3 class 3K3) • Pollution degree: 3 (in accordance with IEC 60664-1) • Vibration resistance: 10 to 55Hz 0,35mm (in accordance with IEC 60068-2-6) • Shock resistance: 15g 11ms (in accordance with IEC 60068-2-27)

Accessories

PowerModulees TR2 (12 to 440V AC) • DC power supply SNT2 24V DC • sealable intervention protection shield FA-G2

Dimensions

Temperature monitoring of the motor winding (max. 6 PTC) with fault latch, for temperature probes in accordance with DIN 44081, test function with integrated test/reset key and the following additional functions (G2TFKN02):

- Off Basic function
- +K Short circuit monitoring of thermistor line
- +N Zero-voltage latch
- +K+N Short circuit monitoring and zero-voltage latch

G2TF01

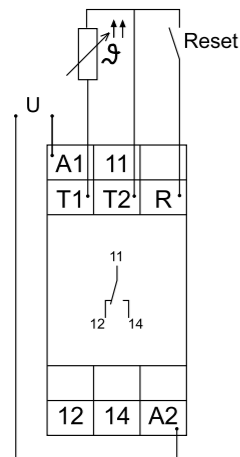

G2TFKN02

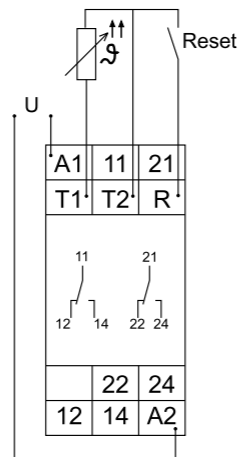

automatic reset by wire link R-T2

automatic reset by wire link R-T2

Width 22,5mm

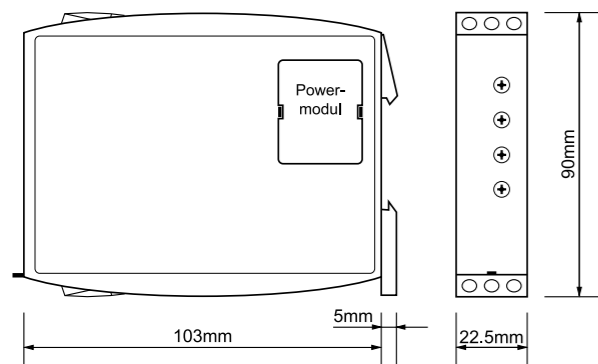

Functions



Sensing & Monitoring Relays Series GAMMA *WatchDog*



Temperature monitoring

- Temperature monitoring of the motor winding in accordance with DIN 44081
- Maximal 6 PTC probes
- Fault latch
- Testfunction with integrated Test/Reset button
- Possibility for external reset
- Supply voltage selectable via PowerModules or by zoom voltage 24 to 240V AC/DC
- 1 CO contact; 2 CO contacts
- Width 22,5mm
- Industrial design

Connections

types

G2TF02 230V AC

G2TF02 110V AC

G2TF01

G2TF01 230V AC



Art.No. (PQ1)

2390104

2390109

2390103

2390102

Art.No. (PQ10)

-

-

-

2390102A

EAN13-Code

900866200241

900866200249

900866200240

900866200238

Measured variable

PTC (motortemperature)
max. 6 PTC probes

PTC (motortemperature)
max. 6 PTC probes

PTC (motortemperature)
max. 6 PTC probes

PTC (motortemperature)
max. 6 PTC probes

Measured range

total resistance cold <1,5kΩ
terminals T1-T2

total resistance cold <1,5kΩ
terminals T1-T2

total resistance cold <1,5kWter-
minals T1-T2

total resistance cold <1,5kWter-
minals T1-T2

Measuring voltage

≤2,5V DC at R ≤4,0kΩ
(DINVDE 0660 part 302)

≤2,5V DC at R ≤4,0kΩ
(DINVDE 0660 part 302)

≤2,5V DC at R ≤4,0kW(DINVDE
0660 Part 302)

≤2,5V DC at R ≤4,0kW(DINVDE
0660 Part 302)

Controls

Test/Reset button

Test/Reset button

Test/Reset button

Test/Reset button

Indicators (LEDs)

U • Failure

U • Failure

U • Failure

U • Failure

Functions

Overtemperature

Overtemperature

Overtemperature

Overtemperature

Response value

3,6kΩ

3,6kΩ

3,6kΩ

3,6kΩ

Release value

1,8kΩ

1,8kΩ

1,8kΩ

1,8kΩ

Short circuit monitoring

-

-

-

-

Fault latch

yes (auto)

yes (auto)

yes (auto)

yes (auto)

Reset

internal or external
terminals R-T2

internal or external
terminals R-T2

internal or external
terminals R-T2

internal or external
terminals R-T2

Supply

230V AC
terminals A1-A2

110V AC
terminals A1-A2

PowerModule TR2 or SNT2
terminals A1-A2

230V AC
terminals A1-A2

Output

2 CO contacts
250V, 5AAC

2 CO contacts
250V, 5AAC

1 CO contact
250V, 5AAC

1 CO contact
250V, 5AAC

Width

22,5mm

22,5mm

22,5mm

22,5mm

Certificates

CE • cULus • GOST

CE • cULus • GOST

CE • cULus • GOST

CE • cULus • GOST

Mechanical design

Self-extinguishing plastic housing, IP rating IP40 • Mounted on DIN-Rail TS 35 in accordance with EN 60715 • Mounting position any • Shockproof terminal connection according to VBG 4 (PZ1 required), IP rating IP20 • Tightening torque max. 1Nm

Terminal capacity

1 x 0,5 to 2,5mm² with/without multicore cable end • 1 x 4mm² without multicore cable end • 2 x 0,5 to 1,5mm² with/without multicore cable end • 2 x 2,5mm² flexible without multicore cable end

Ambient conditions

Ambient temperature: -25 to 55°C (in accordance with IEC 60068-1); -25 to 40°C (in accordance with UL 508) • Storage temperature: -25 to +70°C • Transport temperature: -25 to +70°C • relative humidity: 15% to 85% (in accordance with IEC 60721-3-3 class 3K3) • Pollution degree: 3 (in accordance with IEC 60664-1) • Vibration resistance: 10 to 55Hz 0,35mm (in accordance with IEC 60068-2-6) • Shock resistance: 15g 11ms (in accordance with IEC 60068-2-27)

Accessories

PowerModulees TR2 (12 to 440V AC) • DC power supply SNT2 24V DC • sealable intervention protection shield FA-G2

Dimensions

Temperature monitoring of motor winding (max. 6 PTC) with fault latch for probes in accordance with DIN 44081, testfunction with integrated Test/Reset button.

G2TF02

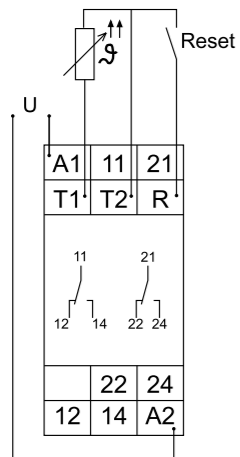

automatic reset by wire link R-T2

Width 22,5mm

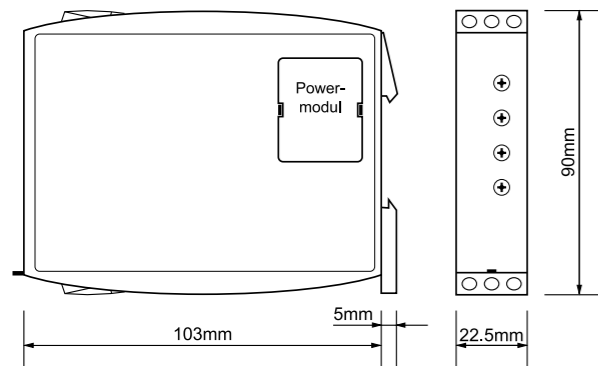

Functions



Sensing & Monitoring Relays Series GAMMA

WatchDog



Level monitoring

- Level monitoring of conductive substances
- Pump up or minimum monitoring
- Pump down or maximum monitoring
- Secure galvanic separation of measuring circuit
- 2 CO contacts
- Width 22,5mm
- Industrial design

Connections

types

G2LM20 24V AC

G2LM20 110V AC

G2LM20 230V AC



Art.No. (PQ1)

2390201

2390202

2390200

Art.No. (PQ10)

-

-

-

EAN13-Code

900866200254

900866200255

900866200253

Measured variable

level with
conductive probe

level with
conductive probe

level with
conductive probe

Measured range

0,25 to 100kΩ

0,25 to 100kΩ

0,25 to 100kΩ

Probe voltage

max. 16V AC

max. 16V AC

max. 16V AC

Probe current

max. 7mA

max. 7mA

max. 7mA

Wiring distance

max. 1000m (adjustment <50%)
max. 100m (adjustment <100%)
capacity of cable 100nF/km

max. 1000m (adjustment <50%)
max. 100m (adjustment <100%)
capacity of cable 100nF/km

max. 1000m (adjustment <50%)
max. 100m (adjustment <100%)
capacity of cable 100nF/km

Control

Delay on • Delay off • Sensitivity • Function

Delay on • Delay off • Sensitivity • Function

Delay on • Delay off • Sensitivity • Function

Indicators (LEDs)

U • R

U • R

U • R

Functions

Pump up
Pump down

Pump up
Pump down

Pump up
Pump down

Trigger level

0,25 to 100 kΩ (Sensitivity)

0,25 to 100 kΩ (Sensitivity)

0,25 to 100 kΩ (Sensitivity)

Tripping delay

0,5s to 10s

0,5s to 10s

0,5s to 10s

Turn-off delay

0,5s to 10s

0,5s to 10s

0,5s to 10s

Supply

24V AC
terminals A1-A2

110V AC
terminals A1-A2

230V AC
terminals A1-A2

Output

2 CO contacts
250V, 5A AC

2 CO contacts
250V, 5A AC

2 CO contacts
250V, 5A AC

Width

22.5mm

22.5mm

22.5mm

Certificates

CE • cULus • GOST

CE • cULus • GOST

CE • cULus • GOST

Mechanical design

Self-extinguishing plastic housing, IP rating IP40 • Mounted on DIN-Rail TS 35 in accordance with EN 60715 • Mounting position any • Shockproof terminal connection according to VBG 4 (PZ1 required) • IP rating IP20 • Tightening torque max. 1Nm

Terminal capacity

1 x 0,5 to 2,5mm² with/without multicore cable end • 1 x 4mm² without multicore cable end • 2 x 0,5 to 1,5mm² with/without multicore cable end • 2 x 2,5mm² flexible without multicore cable end

Ambient conditions

Ambient temperature: -25 to 55°C (in accordance with IEC 60068-1); -25 to 40°C (in accordance with UL 508) • Storage temperature: -25 to +70°C • Transport temperature: -25 to +70°C • relative humidity: 15% to 85% (in accordance with IEC 60721-3-3 class 3K3) • Pollution degree: 3 (in accordance with IEC 60664-1) • Vibration resistance: 10 to 55Hz 0,35mm (in accordance with IEC 60068-2-6) • Shock resistance: 15g 11ms (in accordance with IEC 60068-2-27)

Accessories

conductive probes (types SK1, SK2, SK3) • sealable intervention protection shield FA-G2

Dimensions

Level monitoring of conductive substances, timing for tripping delay and turn-off delay separately adjustable and the following functions:

Pump up Pump up or minimum monitoring
 Pump down Pump down or maximum monitoring

G2LM20

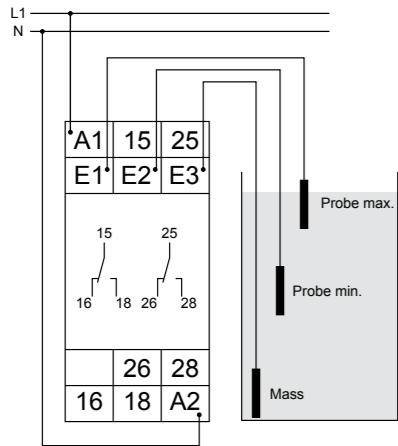

Width 22,5mm

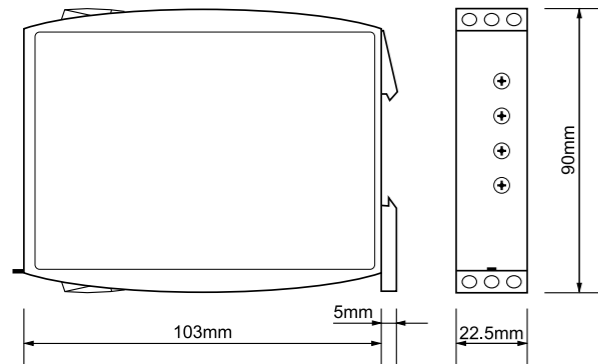

Sensing & Monitoring Relays Series TREND

Voltage monitoring in 3-phase mains



- Windowfunction (TPW...VN4X)
- Windowfunction with integrated phase sequence monitoring (TPW...VSN4X)
- Connection of neutral wire optional
- Supply voltage selectable via PowerModules or DC power supply
- 1 CO contact
- Width 45mm
- Industrial design

Functions

Connections

types

TPW400VSN4X

TPW230VSN4X

TPW115VSN4X

TPW400VN4X



Art.No. (PQ1)

2400008

2401310

2401210

2401410

Art.No. (PQ10)

-

-

-

-

EAN13-Code

900866200298

900866200304

900866200303

900866200305

Measured variable

3(N)~
AC Sinus (48 to 63Hz)

3(N)~
AC Sinus (48 to 63Hz)

3(N)~
AC Sinus (48 to 63Hz)

3(N)~
AC Sinus (48 to 63Hz)

Measured range

$U_N = 400/230V$
terminals (N)-L1-L2-L3

$U_N = 230/133V$
terminals (N)-L1-L2-L3

$U_N = 115/66V$
terminals (N)-L1-L2-L3

$U_N = 400/230V$
terminals (N)-L1-L2-L3

Controls

max • min • Delay (t_1)

max • min • Delay (t_1)

max • min • Delay (t_1)

max • min • Delay (t_1)

Indicators (LEDs)

max • R • min

max • R • min

max • R • min

max • R • min

Functions

WIN+SEQ

WIN+SEQ

WIN+SEQ

WIN

Asymmetry

crabwise by U_{min}/U_{max}

crabwise by U_{min}/U_{max}

crabwise by U_{min}/U_{max}

crabwise by U_{min}/U_{max}

Switching threshold max.

-20% to 30% from U_N

-20% to 30% from U_N

-20% to 30% from U_N

-20% to 30% from U_N

Switching threshold min.

-30% to 20% from U_N

-30% to 20% from U_N

-30% to 20% from U_N

-30% to 20% from U_N

Tripping delay

0,1s to 10s

0,1s to 10s

0,1s to 10s

0,1s to 10s

Start-up suppression time

-

-

-

-

Fault latch

-

-

-

-

Supply

PowerModule TR2 or SNT2
terminals A1-A2

PowerModule TR2 or SNT2
terminals A1-A2

PowerModule TR2 or SNT2
terminals A1-A2

PowerModule TR2 or SNT2
terminals A1-A2

Output

1 CO contact
250V, 5AAC

1 CO contact
250V, 5AAC

1 CO contact
250V, 5AAC

1 CO contact
250V, 5AAC

Width

45mm

45mm

45mm

45mm

Certificates

CE

CE

CE

CE

Mechanical design

Self-extinguishing plastic housing, IP rating IP40 • Mounted on DIN-Rail TS 35 in accordance with EN 60715 • Mounting position any • Shockproof terminal connection according to VBG 4 (PZ1 required) • IP rating IP20 • Tightening torque max. 1Nm

Terminal capacity

1 x 0,5 to 2,5mm² with/without multicore cable end • 1 x 4mm² without multicore cable end • 2 x 0,5 to 1,5mm² with/without multicore cable end • 2 x 2,5mm² flexible without multicore cable end

Ambient conditions

Ambient temperature: -25 to +55°C (in accordance with IEC 60068-1) • Storage temperature: -25 to +70°C • Transport temperature: -25 to +70°C • relative humidity: 15% to 85% (in accordance with IEC 60721-3-3 class 3K3) • Pollution degree: 3 (in accordance with IEC 60664-1)

Accessories

PowerModulees TR2 (12 to 440V AC) • DC power supply SNT2 24V DC

Dimensions

Voltage monitoring in 3-phase mains with adjustable setpoints, adjustable tripping delay and phase sequence monitoring.

WIN Monitoring the window between Min and Max
 WIN+SEQ Monitoring the window between Min and Max and phase sequence monitoring

TPW...N4X; TPW...SN4X

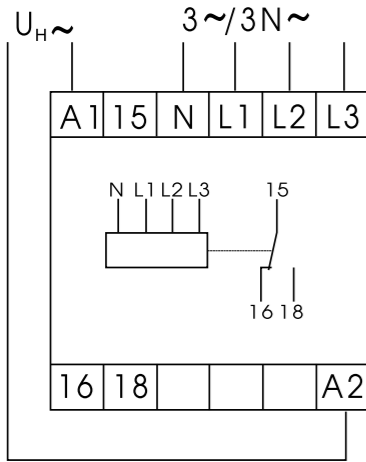

Width 45mm

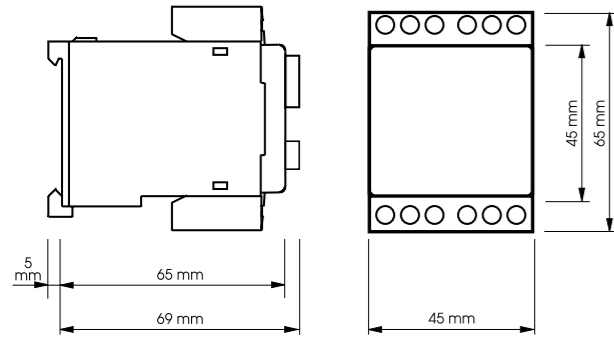

Sensing & Monitoring Relays Series TREND

Voltage monitoring in 3-phase mains



- Phase sequence, phase loss and asymmetry monitoring with fixed asymmetry
- No connection of neutral wire required
- 1 CO contact
- Width 45mm
- Industrial design

Functions

Connections

types

TPF230VS4X

TPF400VS4X



Art.No. (PQ1)

2442153

2402058

Art.No. (PQ10)

-

-

EAN13-Code

900866200315

900866200306

Measured variable

3~
AC Sinus (48 to 63Hz)

3~
AC Sinus (48 to 63Hz)

Measured range

$U_N = 230V/132V$
terminals L1-L2-L3

$U_N = 400V/230V$
terminals L1-L2-L3

Controls

-

-

Indicators (LEDs)

R

R

Functions

Monitoring of phase sequence
and phase failure

Monitoring of phase sequence
and phase failure

Asymmetry

fixed, approx. 10%

fixed, approx. 10%

Switching threshold max.

-

-

Tripping delay

-

-

Start-up suppression time

-

-

Fault latch

-

-

Supply

= measuring voltage; 3~ 230V $\pm 15\%$
terminals L1-L2-L3

= measuring voltage; 3~ 400V $\pm 15\%$
terminals L1-L2-L3

Output

1 CO contact
250V, 5A AC

1 CO contact
250V, 5A AC

Width

45mm

45mm

Certificates

CE

CE

Mechanical design

Self-extinguishing plastic housing, IP rating IP40 • Mounted on DIN-Rail TS 35 in accordance with EN 60715 • Mounting position any • Shockproof terminal connection according to VBG 4 (PZ1 required) • IP rating IP20 • Tightening torque max. 1Nm

Terminal capacity

1 x 0,5 to 2,5mm² with/without multicore cable end • 1 x 4mm² without multicore cable end • 2 x 0,5 to 1,5mm² with/without multicore cable end • 2 x 2,5mm² flexible without multicore cable end

Ambient conditions

Ambient temperature: -25 to +55°C (in accordance with IEC 60068-1) • Storage temperature: -25 to +70°C • Transport temperature: -25 to +70°C • relative humidity: 15% to 85% (in accordance with IEC 60721-3-3 class 3K3) • Pollution degree: 3 (in accordance with IEC 60664-1)

Accessories

-

Dimensions

Phase sequence, phase loss and asymmetry monitoring with fixed asymmetry, no connection of neutral wire necessary.

TPF...S4X

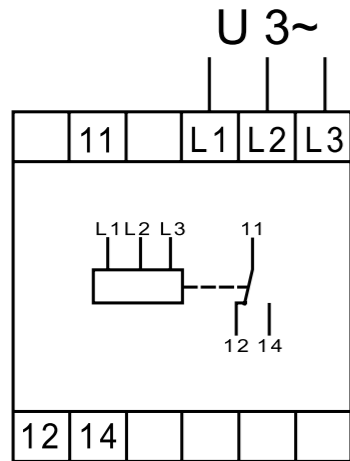

Width 45mm

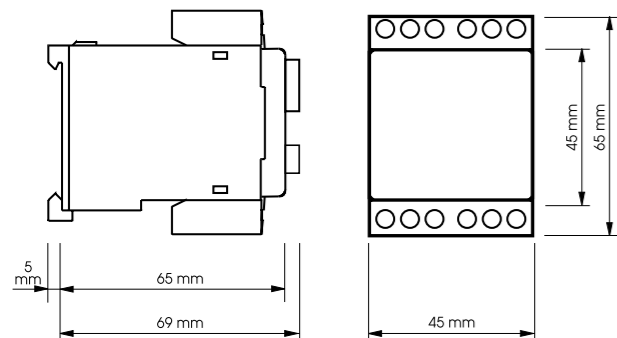

Functions



Sensing & Monitoring Relays Series TREND

Voltage monitoring in 1-phase mains



- Windowfunction or reverse Windowfunction (TUW4X)
- 1 trigger level with adjustable hysteresis OVER/UNDER (TUH4X)
- Position of output relay selectable
- DIP-Switch for adjusting to AC/DC monitoring and relay position
- Fault latch
- Supply voltage selectable via PowerModules or DC power supply
- 1 CO contact
- Width 45mm
- Industrial design

Connections

types

TUW4X

TUH4X



Art.No. (PQ1)

2420510

2422510

Art.No. (PQ10)

-

-

EAN13-Code

900866200308

900866200309

Measured variable

Voltage AC/DC
AC Sinus (48 to 63Hz)

Voltage AC/DC
AC Sinus (48 to 63Hz)

Measuring ranges (U_N)

24V AC/DC; terminals E1-F1(+)
115V AC/DC; terminals E1-F2(+)
230V AC/DC; terminals E1-F3(+)
440V AC/DC; terminals E2-F3(+)

30V AC/DC; terminals E1-F1(+)
60V AC/DC; terminals E1-F2(+)
300V AC/DC; terminals E1-F3(+)
600V AC/DC; terminals E2-F3(+)

Controls

max • min • Delay (t_1) • Start (t_2) • AC/DC • REL/REL • Start On/Off

U_s • Hyst • Delay (t_1) • Start (t_2) • AC/DC • REL/REL • Start On/Off

Indicators (LEDs)

max • R • min

U • R

Functions

WIN • reverse WIN

1 trigger level with hysteresis (OVER/UNDER)

Switching threshold max.

-20% to 30% from U_N

trigger level U_s : 10% to 100% from U_N

-30% to 20% from U_N

Hysteresis: 5% to 50% from U_s

Tripping delay

$t_1 = 0,1s$ to 10s

$t_1 = 0,1s$ to 10s

Start-up suppression time

$t_2 = 0,1s$ to 10s

$t_2 = 0,1s$ to 10s

Fault latch

selectable

selectable

Supply

PowerModule TR2 or SNT2
terminals A1-A2

PowerModule TR2 or SNT2
terminals A1-A2

Output

1 CO contact
250V, 5A AC

1 CO contact
250V, 5A AC

Width

45mm

45mm

Certificates

CE

CE

Mechanical design

Self-extinguishing plastic housing, IP rating IP40 • Mounted on DIN-Rail TS 35 in accordance with EN 60715 • Mounting position any • Shockproof terminal connection according to VBG 4 (PZ1 required) • IP rating IP20 • Tightening torque max. 1Nm

Terminal capacity

1 x 0,5 to 2,5mm² with/without multicore cable end • 1 x 4mm² without multicore cable end • 2 x 0,5 to 1,5mm² with/without multicore cable end • 2 x 2,5mm² flexible without multicore cable end

Ambient conditions

Ambient temperature: -25 to +55°C (in accordance with IEC 60068-1) • Storage temperature: -25 to +70°C • Transport temperature: -25 to +70°C • relative humidity: 15% to 85% (in accordance with IEC 60721-3-3 class 3K3) • Pollution degree: 3 (in accordance with IEC 60664-1)

Accessories

PowerModulees TR2 (12 to 440V AC) • DC power supply SNT2 24V DC

Dimensions

TUW:
AC/DC voltage monitoring in 1-phase mains with adjustable thresholds, timing for start-up suppression and tripping delay separately adjustable and the following functions (selectable by means of DIP switch)

DIP-Switch 1: AC/DC preselection
DIP-Switch 2: Monitoring inside (W) or outside (R) the window between U_{min} and U_{max}
DIP-Switch 3: ON Relay picks up during the start-up suppression time (t_2)
OFF Relay remains in off position during the start-up suppression time (t_2)

TUH:
AC/DC overvoltage monitoring in 1-phase mains with adjustable threshold, timing for start-up suppression and tripping delay separately adjustable and adjustable hysteresis and the following functions (selectable by means of DIP-switch)

DIP-Switch 1: AC/DC preselection
DIP-Switch 2: REL relay in on-position if error occurs REL relays in off-position if error occurs
DIP-Switch 3: ON Relay picks up during the start-up suppression time (t_2)
OFF Relay remains in off position during the start-up suppression time (t_2)

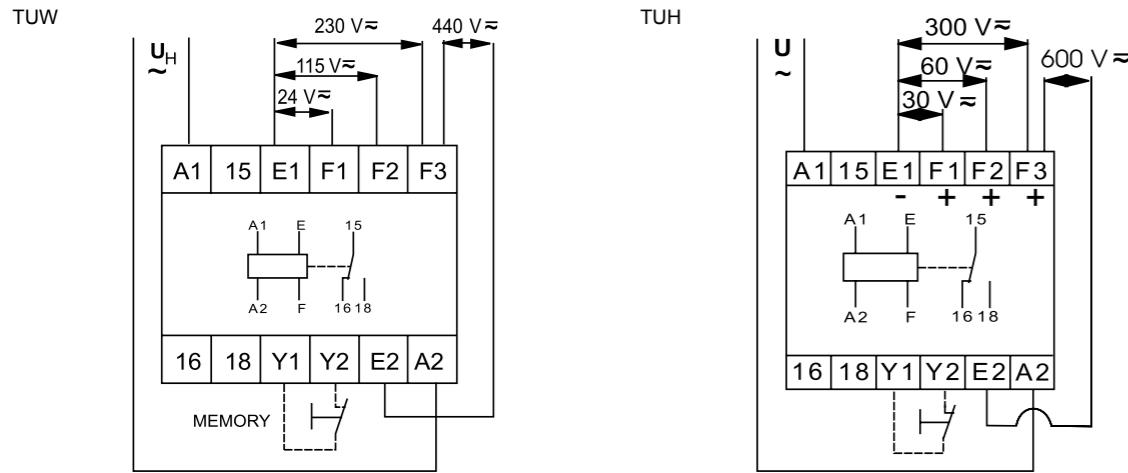

Width 45mm

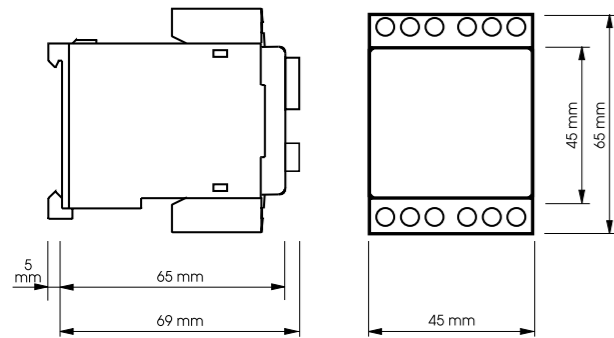

Functions

- Windowfunction (TIW4X)
- 2 trigger level (TIF)
- Hysteresis OVER/UNDER (TIH4X)
- Position of output relay selectable (TIW4X; TIH4X)
- DIP-Switch for adjusting to AC/DC monitoring and relay position (TIW4X; TIH4X)
- Fault latch (TIW4X; TIH4X)
- Permissible continuous load on measuring input 15A(TIF)
- Supply voltage selectable via PowerModules or DC power supply (TIW4X; TIH4X)
- 1 CO contact; 2 CO contacts; Width 45mm; Industrial design

Connections

types

TIW4X

TIH4X

TIF30-300mAAC4X



Art.No. (PQ1)

2430890

2432610

2432894

Art.No. (PQ10)

-

-

-

EAN13-Code

900866200311

900866200312

900866200313

Measured variable

Current AC/DC
AC Sinus (48 to 63Hz)

Current AC/DC
AC Sinus (48 to 63Hz)

Current AC
AC Sinus (48 to 63Hz)

Measuring ranges

100mA AC/DC; terminals K-13(+)
1A AC/DC; terminals K-12(+)
10A AC/DC; terminals K-11(+)

100mA AC/DC; terminals K-13(+)
1A AC/DC; terminals K-12(+)
10A AC/DC; terminals K-11(+)

15A AC; terminals K-1

Controls

max • min • Delay (t_1) • Start (t_2) • AC/DC • REL/REL • Start On/Off

I_s • Hyst • Delay (t_1) • Start (t_2) • AC/DC • REL/REL • Start On/Off

-

Indicators (LEDs)

max • R • min

U • R

U • R

Functions

WIN

1 trigger level with hysteresis (OVER/UNDER)

UNDER

Switching threshold max.

10% to 100% from I_N

trigger level I_s : 10% to 100% from I_N

fixed, 30mA
fixed, 300mA

5% to 50% from I_N

Hysteresis: 5% to 50% from I_s

Hysteresis: fixed, approx. 5%

Tripping delay

$t_1 = 0,1s$ to 10s

$t_1 = 0,1s$ to 10s

-

Start-up suppression time

$t_2 = 0,1s$ to 10s

$t_2 = 0,1s$ to 10s

-

Fault latch

selectable

selectable

-

Supply

PowerModule TR2 or SNT2
terminals A1-A2

PowerModule TR2 or SNT2
terminals A1-A2

230V AC
terminals A1-A2

Output

1 CO contact
250V, 5A AC

1 CO contact
250V, 5A AC

2 CO contacts
250V, 5A AC

Width

45mm

45mm

45mm

Certificates

CE

CE

CE

Mechanical design

Self-extinguishing plastic housing, IP rating IP40 • Mounted on DIN-Rail TS 35 in accordance with EN 60715 • Mounting position any • Shockproof terminal connection according to VBG 4 (PZ1 required) • IP rating IP20 • Tightening torque max. 1Nm

Terminal capacity

1 x 0,5 to 2,5mm² with/without multicore cable end • 1 x 4mm² without multicore cable end • 2 x 0,5 to 1,5mm² with/without multicore cable end • 2 x 2,5mm² flexible without multicore cable end

Ambient conditions

Ambient temperature: -25 to +55°C (in accordance with IEC 60068-1) • Storage temperature: -25 to +70°C • Transport temperature: -25 to +70°C • relative humidity: 15% to 85% (in accordance with IEC 60721-3-3 class 3K3) • Pollution degree: 3 (in accordance with IEC 60664-1)

Accessories

PowerModulees TR2 (12 to 440V AC) • DC power supply SNT2 24V DC • Current Transformers DWS and WSW

Sensing & Monitoring Relays Series TREND

Current monitoring in 1-phase mains



TIW: AC/DC current monitoring in 1-phase mains with adjustable thresholds, timing for start-up suppression and tripping delay separately adjustable and the following functions (selectable by means of DIP-switch)

DIP-Switch 1: AC/DC preselection
 DIP-Switch 2: W Monitoring inside (W) the window between I_{min} and I_{max}
 R Monitoring outside (R) the window between I_{min} and I_{max}
 DIP-Switch 3: ON Relay picks up during the start-up suppression time (t_2)
 OFF Relay remains in off position during the start-up suppression time (t_2)

TIH: AC/DC overcurrent monitoring in 1-phase mains with adjustable threshold, timing for start-up suppression and tripping delay separately adjustable and adjustable hysteresis and the following functions (selectable by means of DIP-switch)

DIP-Switch 1: AC/DC preselection
 DIP-Switch 2: REL relay in on-position if error occurs. \overline{REL} relays in off-position if error occurs
 DIP-Switch 3: ON Relay picks up during the start-up suppression time (t_2)
 OFF Relay remains in off position during the start-up suppression time (t_2)

TIF: Consumer failure detection for AC-current in 1-phase mains with 2 fixed thresholds (selectable via bridge X1-X2)

TIW4X; TIH4X

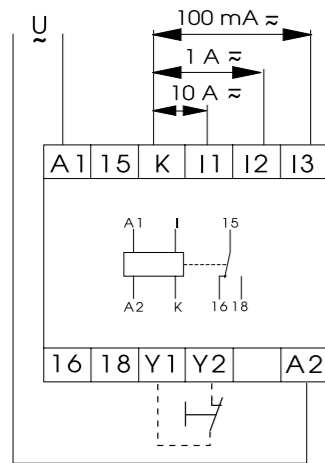

TIF30-300mAAC4X

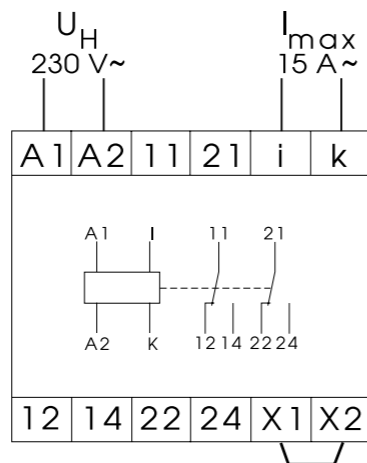

Width 45mm

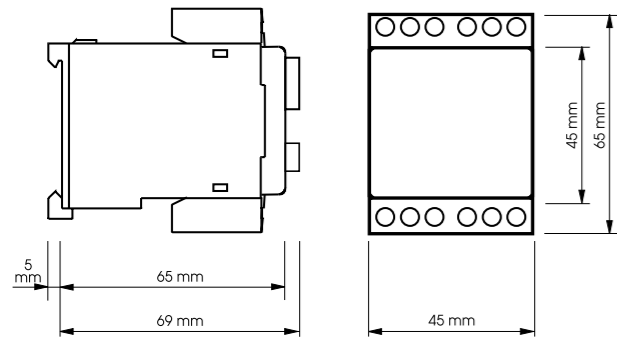

Functions



Sensing & Monitoring Relays Series TREND

Temperature monitoring

- Temperature monitoring of motor winding
- Maximum of 6 PTC probes per measuring circuit
- 2 measuring circuits (TDT4X)
- Fault latch for measuring circuit 2 (TDT4X)
- Short circuit monitoring of PTC circuits
- Supply voltage selectable via PowerModules or DC power supply (TDT4X)
- 1 NO contact; 1 CO contact per measuring circuit (TDT4X)
- Width 22,5mm or 45mm
- Industrial design



Connections

types

TDT4X

TT2X 24V AC

TT2X 230V AC



Art.No. (PQ1)

2480090

2480052

2480054

Art.No. (PQ10)

-

-

-

EAN13-Code

900866200328

900866200325

900866200327

Measured variable

2 x PTC (motortemperature)
max. 2 x 6 PTC probes

PTC (motortemperature)
max. 6 PTC probes

PTC (motortemperature)
max. 6 PTC probes

Measured range

total resistance cold <1.5k Ω
terminals 1T1-T2 (circuit 1)
terminals 2T1-T2 (circuit 2)

total resistance cold <1.5k Ω
terminals T1-T2

total resistance cold <1.5k Ω
terminals T1-T2

Measuring voltage

max. 12V DC

max. 12V DC

max. 12V DC

Controls

Test/Reset button

-

-

Indicators (LEDs)

U • Failure 1T1-T2 •
Failure 2T1-T2

U • Failure

U • Failure

Functions

Overtemperature

Overtemperature

Overtemperature

Response value

3,3k Ω

3,3k Ω

3,3k Ω

Release value

1,8k Ω

1,8k Ω

1,8k Ω

Short circuit monitoring

<15 Ω

<15 Ω

<15 Ω

Fault latch

yes (circuit 2)

-

-

Reset

internal or external
terminals 2R1-T2/2R2

-

-

Supply

PowerModule TR2 or SNT2
terminals A1-A2

24V AC
terminals A1-A2

230V AC
terminals A1-A2

Output

1 CO contact each circuit
250V, 5AAC

1 NO contact
250V, 5AAC

1 NO contact
250V, 5AAC

Width

45mm

22,5mm

22,5mm

Certificates

CE

CE

CE

Mechanical design

Self-extinguishing plastic housing, IP rating IP40 • Mounted on DIN-Rail TS 35 in accordance with EN 60715 • Mounting position any • Shockproof terminal connection according to VBG 4 (PZ1 required) • IP rating IP20 • Tightening torque max. 1Nm

Terminal capacity

1 x 0,5 to 2,5mm² with/without multicore cable end • 1 x 4mm² without multicore cable end • 2 x 0,5 to 1,5mm² with/without multicore cable end • 2 x 2,5mm² flexible without multicore cable end

Ambient conditions

Ambient temperature: -25 to +55°C (in accordance with IEC 60068-1) • Storage temperature: -25 to +70°C • Transport temperature: -25 to +70°C • relative humidity: 15% to 85% (in accordance with IEC 60721-3-3 class 3K3) • Pollution degree: 3 (in accordance with IEC 60664-1)

Accessories

PowerModulees TR2 (12 to 440V AC) • DC power supply SNT2 24V DC

Dimensions

Temperature monitoring of motor winding (max. 6 PTC) with fault latch (only measuring circuit 2) for probes in accordance with DIN 44081
Short circuit monitoring of PTC circuits



Sensing & Monitoring Relays Series TREND



Level monitoring

- Level monitoring of conductive substances
- Pump up or minimum monitoring
- Pump down or maximum monitoring
- 1 CO contact
- Width 45mm
- Industrial design

TDT4X

TT2X

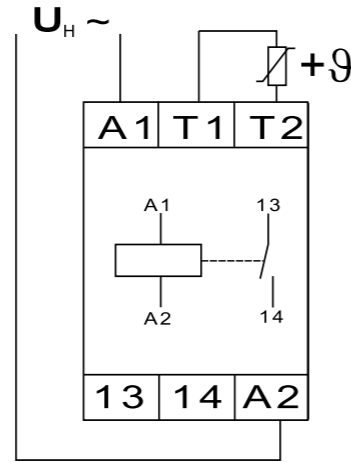
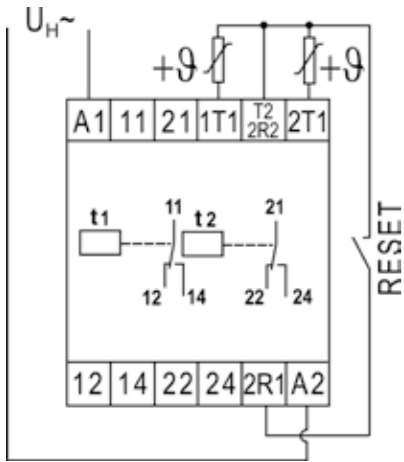

Width 22,5mm

Width 45mm

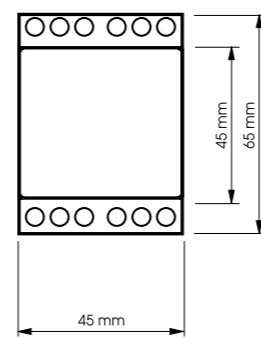
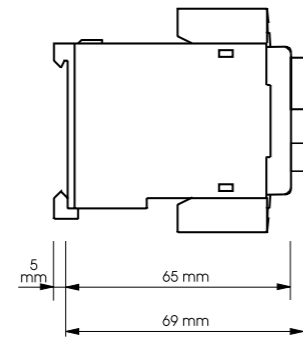
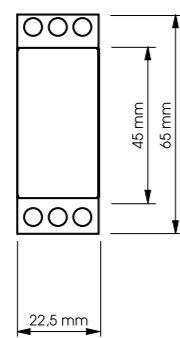
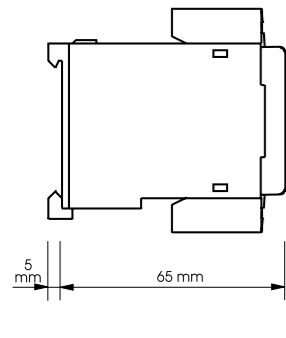

Connections

types

TLH4X 24V AC

TLH4X 230V AC

TLC4X 230V AC



Art.No. (PQ1)

2472012

2472014

2472114

Art.No. (PQ10)

-

-

-

EAN13-Code

900866200317

900866200318

900866200323

Measured variable

conductive probe min.
conductive probe max.
terminals E1-E2-E3

conductive probe min.
conductive probe max.
terminals E1-E2-E3

conductive probe min.
conductive probe max.
terminals E1-E2-E3

Measuring ranges

0,25 to 5k Ω / 5 to 100k Ω

0,25 to 5k Ω / 5 to 100k Ω

5 to 100k Ω

Probe voltage

max. 16VAC

max. 16VAC

max. 16VAC

Probe current

max. 7mA / max. 200 μ A

max. 7mA / max. 200 μ A

max. 200 μ A

Wiring distance

max. 1000m / max. 100m

max. 1000m / max. 100m

max. 100m

Control

Sensitivity • Delay on (t_1) • Delay off (t_2) •
Function • Measuring ranges

Sensitivity • Delay on (t_1) • Delay off (t_2) •
Function • Measuring ranges

Sensitivity • Function

Indicators (LEDs)

U • R

U • R

U • R

Functions

Pump up
Pump down

Pump up
Pump down

Pump up
Pump down

Trigger level

0,25 to 5k Ω / 5 to 100k Ω
(Sensitivity)

0,25 to 5k Ω / 5 to 100k Ω
(Sensitivity)

5 to 100k Ω
(Sensitivity)

Tripping delay

0,5s to 10s (t_1)

0,5s to 10s (t_1)

2s fixed

Turn-off delay

0,5s to 10s (t_2)

0,5s to 10s (t_2)

2s fixed

Supply

24V AC
terminals A1-A2

230V AC
terminals A1-A2

230V AC
terminals A1-A2

Output

1 CO contact
250V, 5AAC

1 CO contact
250V, 5AAC

1 CO contact
250V, 5AAC

Width

45mm

45mm

45mm

Certificates

CE

CE

CE

Mechanical design

Self-extinguishing plastic housing, IP rating IP40 • Mounted on DIN-Rail TS 35 in accordance with EN 60715 • Mounting position any • Shockproof terminal connection according to VBG 4 (PZ1 required) • IP rating IP20 • Tightening torque max. 1Nm

Terminal capacity

1 x 0,5 to 2,5mm² with/without multicore cable end • 1 x 4mm² without multicore cable end • 2 x 0,5 to 1,5mm² with/without multicore cable end • 2 x 2,5mm² flexible without multicore cable end

Ambient conditions

Ambient temperature: -25 to +55°C (in accordance with IEC 60068-1) • Storage temperature: -25 to +70°C • Transport temperature: -25 to +70°C • relative humidity: 15% to 85% (in accordance with IEC 60721-3-3 class 3K3) • Pollution degree: 3 (in accordance with IEC 60664-1)

Accessories

conductive probes (types SK1, SK2, SK3)

Dimensions

Ambient conditions

Ambient temperature: -25 to +55°C (in accordance with IEC 60068-1) • Storage temperature: -25 to +70°C • Transport temperature: -25 to +70°C • relative humidity: 15% to 85% (in accordance with IEC 60721-3-3 class 3K3) • Pollution degree: 3 (in accordance with IEC 60664-1)

Accessories

conductive probes (types SK1, SK2, SK3)

TLH:
Level monitoring of conductive substances, timing for tripping delay and turn-off delay separately adjustable and the following functions:

Pump down Pump down or maximum monitoring
Pump up Pump up or minimum monitoring

TLC:
Level monitoring of conductive substances with adjustable threshold, fixed tripping delay and turn-off delay and the following functions:

Pump down Pump down or maximum monitoring
Pump up Pump up or minimum monitoring

Connection of 3-probes (pump up/down)

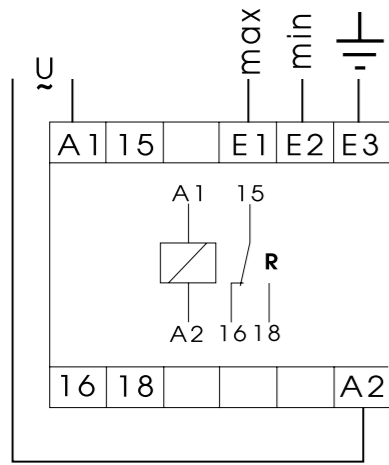

Connection of 2-probes (Minimum-/Maximum monitoring)

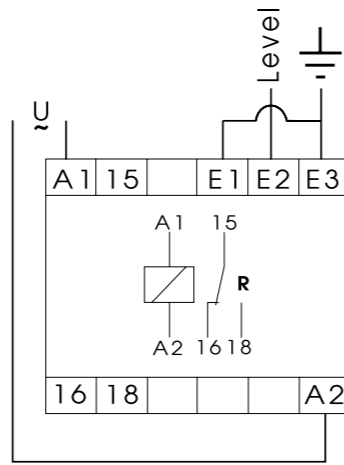

Width 45mm

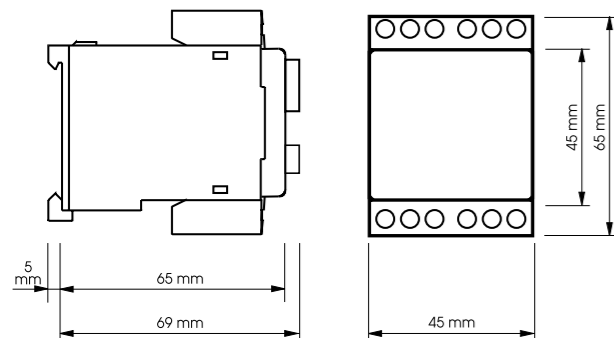

Functions



Sensing & Monitoring Relays Series KAPPA



Voltage and current monitoring of mains



- AC voltage monitoring in 1- and 3-phase mains (K3YM)
- AC/DC voltage monitoring in 1-phase mains (K3UM)
- AC current monitoring in 1-phase mains (K3IM)
- Monitoring of phase sequence, phase failure and asymmetry (K3PF)
- Monitoring of phase failure; monitoring of phase sequence selectable (K3YM)
- Multifunction (K3YM; K3IM; K3UM)
- Supply voltage = measuring voltage (K3PF; K3YM; K3UM)
- Supply voltage = 230V (K3IM)
- 2 CO contacts; Width 38mm; Plug-in mounting

Connections

| types | K3YM400VSY20 | K3PF400VSY02 | K3UM230VAC02 | K3UM24VDC02 | K3IM5AACL20 230V |
|-------|--------------|--------------|--------------|-------------|------------------|
|-------|--------------|--------------|--------------|-------------|------------------|



| | | | | | |
|---------------------------|---|---|--|---|---|
| Art.No. (PQ1) | 1380402 | 1380301 | 1380107 | 1380106 | 1380202 |
| Art.No. (PQ10) | - | - | - | - | - |
| EAN13-Code | 9008662005419 | 9008662005426 | 9008662005396 | 9008662005402 | 9008662005433 |
| Measured variable | 3(N)~ AC Sinus (48 to 63Hz) | 3(N)~ AC Sinus (48 to 63Hz) | Voltage AC AC Sinus (48 to 63Hz) | Voltage DC | Current AC AC Sinus (48 to 63Hz) |
| Measured range | $U_N = 400/230V$ pins (S10)-S5-S6-S7 | $U_N = 400/230V$ pins (S10)-S5-S6-S7 | 230V AC pins S5-S7 | 24V DC pins S5-S7 | 5A AC pins S5-S7 |
| Control | ASYM • Max • Min • Function / Delay | ASYM | Max • Min • Function | Max • Min • Function | Start • Max • Min • Function • Delay |
| Indicators (LEDs) | ASYM • SEQ • Max • Min • R | U • R | U • Max • Min • R | U • Max • Min • R | U/t • Max • Min • R |
| Functions | UNDER • UNDER+SEQ • WIN • WIN+SEQ | Monitoring of phase sequence, phase failure and asymmetry | UNDER • WIN | UNDER • WIN | OVER • OVER+Latch • UNDER • UNDER+Latch • WIN • WIN+Latch |
| Asymmetry | 5% to 30%; Off | 5% to 30%; Off | - | - | - |
| Switching threshold max. | 80% to 130% of U_N | - | 80% to 120% of U_N | 80% to 130% of U_N | 10% to 100% of I_N |
| Switching threshold min. | 70% to 120% of U_N | - | 70% to 110% of U_N | 75% to 125% of U_N | 5% to 95% of I_N |
| Hysteresis | adjustable | - | adjustable | adjustable | adjustable |
| Tripping delay | 0,1s to 10s | fixed circa 100ms | - | - | 0,1s to 10s |
| Start-up suppression time | - | - | - | - | 0s to 10s |
| Fault latch | - | - | - | - | selectable |
| Supply | = measuring voltage 3(N)~400/230V -30% to +30% pins (S10)-S5-S6-S7 | = measuring voltage 3(N)~400/230V -30% to +30% pins (S10)-S5-S6-S7 | = measuring voltage 230V AC -30% to +20% pins S5-S7 | = measuring voltage 24V DC -25% to +30% pins S5-S7 | 230V AC -15% to +10% pins S2-S10 |
| Output | 2 CO contacts 250V, 5A AC | 2 CO contacts 250V, 5A AC | 2 CO contacts 250V, 5A AC | 2 CO contacts 250V, 5A AC | 2 CO contacts 250V, 5A AC |
| Width | 38mm | 38mm | 38mm | 38mm | 38mm |
| Certificates | CE • GOST | CE • GOST | CE • GOST | CE • GOST | CE • GOST |
| Mechanical design | Self-extinguishing plastic housing, IP rating IP40 • Mounted on 11-pole screw terminal socket in accordance with IEC 60067-1-18a • Mounting position any | | | | |
| Ambient conditions | Ambient temperature: -25 to +55°C (in accordance with IEC 60068-1) • Storage temperature: -25 to +70°C • Transport temperature: -25 to +70°C • relative humidity: 15% to 85% (in accordance with IEC 60721-3-3 class 3K3) • Pollution degree: 2, if built in 3 (in accordance with IEC 60664-1) | | | | |
| Accessories | Relay socket R11X, ES12 | | | | |

Dimensions

K3YM: Voltage monitoring in 1-phase- and 3-phase mains with adjustable thresholds, adjustable tripping delay, monitoring of phase failure and monitoring of phase sequence selectable.

K3IM: AC current monitoring in 1-phase mains with adjustable thresholds, adjustable hysteresis and tripping delay.

K3UM: AC/DC voltage monitoring in 1-phase mains with adjustable thresholds and adjustable hysteresis.

K3PF: Monitoring of phase sequence, phase failure and asymmetry with adjustable asymmetry, connection of neutral wire optional.

| | |
|-------------|--|
| OVER | Overcurrent monitoring |
| UNDER | Undercurrent or undervoltage monitoring |
| WIN | Monitoring the window between Min and Max |
| OVER+Latch | Overcurrent monitoring with fault latch |
| UNDER+Latch | Undercurrent monitoring with fault latch |
| WIN+Latch | Monitoring the window between Min and Max with fault latch |
| UNDER+SEQ | Undervoltage monitoring and monitoring of phase sequence |
| WIN+SEQ | Monitoring the window between Min and Max and monitoring of phase sequence |

K3UM24VDC02

K3UM230VAC02

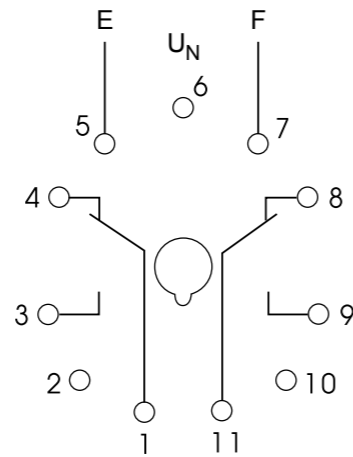
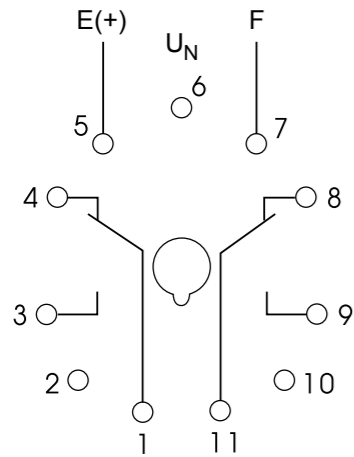

K3IM5AACL20 230V

K3PF400VSY02

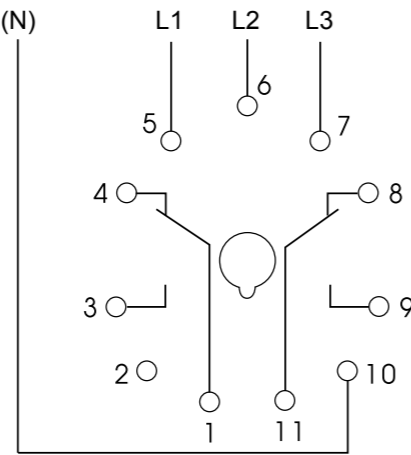
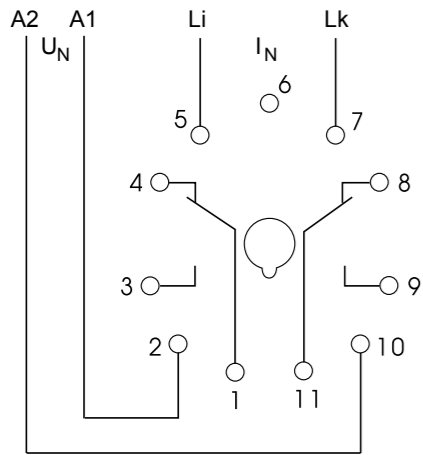

K3YM400VSY20

Width 38mm

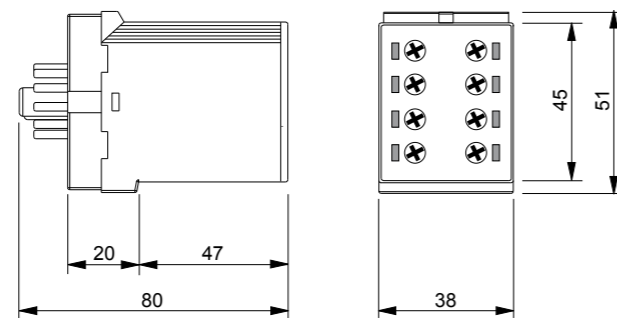
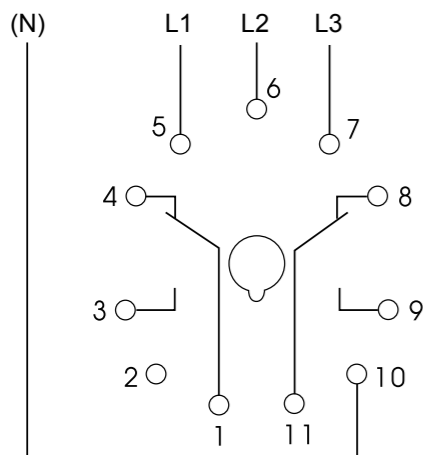

Functions



Sensing & Monitoring Relays Series ENYA



Voltage monitoring in 3- and 1-phase mains

- UNDERvoltage monitoring
- Integrated testswitch (E3YF400VT02 0.85)
- Start-up delay time in accordance with VDE 0108-100 and VDE 0100-718 (E3YF400VE20 0.85)
- Supply voltage = measuring voltage
- 2 CO contacts
- Width 35mm
- Installation design

Connections

types

E3YF400V02 0.85

E3YF400VE20 0.85

E3YF400VT02 0.85

E3YF400VT02 HTV 0.85



Art.No. (PQ1)

1341401

1341404

1341402

1341407

Art.No. (PQ10)

-

-

-

-

EAN13-Code

9008662005303

9008662005785

9008662005297

9008662006416

Measured variable

3N~
AC Sinus (48 to 63Hz)

3N~
AC Sinus (48 to 63Hz)

3N~
AC Sinus (48 to 63Hz)

3N~
AC Sinus (48 to 63Hz)

Measured range

$U_N = 400/230V$
terminals N-L1-L2-L3

$U_N = 400/230V$
terminals N-L1-L2-L3

$U_N = 400/230V$
terminals N-L1-L2-L3

$U_N = 400/230V$
terminals N-L1-L2-L3

Control

-

-

Testfunction

Testfunction

Indicators (LEDs)

U • R

L1 • L2 • L3 • R

L1 • L2 • L3 • R

L1 • L2 • L3 • R

Functions

UNDER

UNDER

UNDER
TEST (R=OFF)

UNDER
TEST (R=OFF)

Asymmetry

-

-

-

-

Switching threshold max.

-

-

-

-

Switching threshold min.

fixed 195,5V (L-N)
in accordance with
VDE 0100-718
VDE 0108-100
 $0,85 \times U_N$

fixed 195,5V (L-N)
in accordance with
VDE 0100-718
VDE 0108-100
 $0,85 \times U_N$

fixed 195,5V (L-N)
in accordance with
VDE 0100-718
VDE 0108-100
 $0,85 \times U_N$

fixed 195,5V (L-N)
in accordance with
VDE 0100-718
VDE 0108-100
 $0,85 \times U_N$

Hysteresis

approx. 5%

approx. 5%

approx. 5%

approx. 5%

Tripping delay

fixed, approx. 200ms

fixed, < 500ms

fixed, approx. 200ms

fixed, approx. 200ms

Start-up delay time

-

60 sec

-

-

Fault latch

-

-

-

-

Supply

= measuring voltage
3N~400/230V -30% to +10%
terminals N-L1-L2-L3

= measuring voltage
3N~400/230V -30% to +10%
terminals N-L1-L2-L3

= measuring voltage
3N~400/230V -30% to +10%
terminals N-L1-L2-L3

= measuring voltage
3N~400/230V -30% to +10%
terminals N-L1-L2-L3

Output

2 CO contacts
250V, 5AAC

2 CO contacts
250V, 5AAC

2 CO contacts
250V, 5AAC

2 CO contacts
250V, 5AAC

Width

35mm

35mm

35mm

35mm

Certificates

CE • cULus • GOST

CE • cULus • GOST

CE • cULus • GOST

CE • cULus • GOST

Mechanical design

Self-extinguishing plastic housing, IP rating IP40 • Mounted on DIN-Rail TS 35 in accordance with EN 60715 • Mounting position any • Shockproof terminal connection according to VBG 4 (PZ1 required), IP rating IP20 • Tightening torque max. 1Nm

Terminal capacity

1 x 0,5 to 2,5mm² with/without multicore cable end • 1 x 4mm² without multicore cable end • 2 x 0,5 to 1,5mm² with/without multicore cable end • 2 x 2,5mm² flexible without multicore cable end

Ambient conditions

Ambient temperature: -25 to +55°C (in accordance with IEC 60068-1) • Storage temperature: -25 to +70°C • Transport temperature: -25 to +70°C • relative humidity: 15% to 85% (in accordance with IEC 60721-3-3 class 3K3) • Pollution degree: 2 (in accordance with IEC 60664-1)

Accessories

-

Connections

Dimensions

E3YF400V02 0.85
 Undervoltage monitoring in single-phase and 3-phase mains
 UNDER Undervoltage monitoring

E3YF400VT02 0.85
 Undervoltage monitoring in single-phase and 3-phase mains
 UNDER Undervoltage monitoring
 T Integrated test switch

E3YF400VE20 0.85
 Undervoltage monitoring in single-phase and 3-phase mains
 UNDER Undervoltage monitoring
 On delay as per VDE 0100-718

E3YF

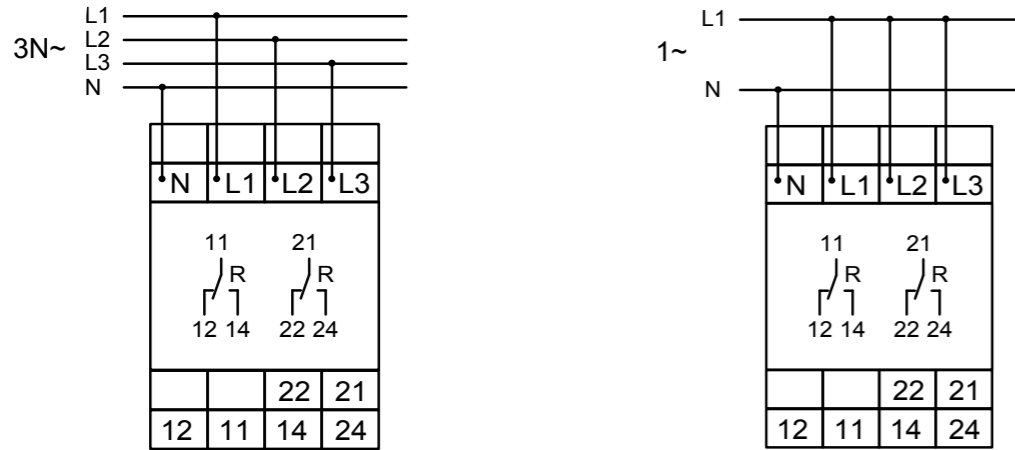

E3YF

E3YF

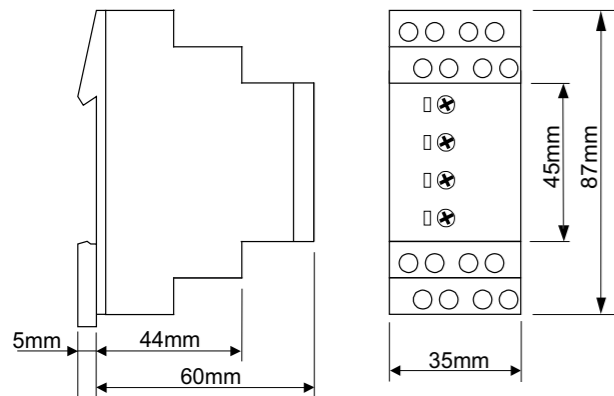

Width 35mm

Functions



Sensing & Monitoring Relays Series ENYA

Voltage monitoring in 3- and 1-phase mains

WatchDog



- Undervoltage monitoring
- Integrated testswitch (E1YF400VT01 0.85)
- Supply voltage = measuring voltage
- 1 CO contact
- Width 17,5mm
- Installation design

Connections

Type

E1YF400V01 0.85

E1YF400VT01 0.85

E1YF400V01 0.70



Art.No. (PQ1)

1340402

1340406

1340410

Art.No. (PQ10)

1340402A

-

-

EAN13-Code

900866200057

900866200487

9008662006140

Measured variable

3N~
AC Sinus (48 to 63Hz)

3N~
AC Sinus (48 to 63Hz)

3N~
AC Sinus (48 to 63Hz)

Measured range

$U_N = 400/230V$
terminals N-L1-L2-L3

$U_N = 400/230V$
terminals N-L1-L2-L3

$U_N = 400/230V$
terminals N-L1-L2-L3

Control

-

Testfunction

-

Indicators (LEDs)

R

L1 • L2 • L3 • R

R

Functions

UNDER

UNDER
TEST (R=OFF)

UNDER

Asymmetry

-

-

-

Switching threshold min.

-

-

-

Switching threshold min.

fixed 195,5V (L-N)
in accordance with
VDE 0100-718
VDE 0108-100
 $0,85 \times U_N$

fixed 195,5V (L-N)
in accordance with
VDE 0100-718
VDE 0108-100
 $0,85 \times U_N$

fixed 161V (L-N)

Hysteresis

ca. 5%

ca. 5%

ca. 5%

Tripping delay

fixed, ca. 200ms

fixed, ca. 200ms

fixed, ca. 200ms

Start-up delay time

-

-

-

Fault latch

-

-

-

Supply

= measuring voltage
3N~400/230V -30% to +10%
terminals N-L1-L2-L3

= measuring voltage
3N~400/230V -30% to +10%
terminals N-L1-L2-L3

= measuring voltage
3N~400/230V -30% to +10%
terminals N-L1-L2-L3

Output

1 CO contact
250V, 5AAC

1CO contact
250V, 5AAC

1 CO contact
250V, 5AAC

Width

17,5mm

17,5mm

17,5mm

Certificates

CE • cULus • GOST

CE • cULus • GOST

CE • GOST

Mechanical design

Self-extinguishing plastic housing, IP rating IP40 • Mounted on DIN-Rail TS 35 in accordance with EN 60715 • Mounting position any • Shockproof terminal connection according to VBG 4 (PZ1 required), IP rating IP20 • Tightening torque max. 1Nm

Terminal capacity

1 x 0,5 to 2,5mm² with/without multicore cable end • 1 x 4mm² without multicore cable end • 2 x 0,5 to 1,5mm² with/without multicore cable end • 2 x 2,5mm² flexible without multicore cable end

Ambient conditions

Ambient temperature: -25 to +55°C (in accordance with IEC 60068-1) • Storage temperature: -25 to +70°C • Transport temperature: -25 to +70°C • relative humidity: 15% to 85% (in accordance with IEC 60721-3-3 class 3K3) • Pollution degree: 2 (in accordance with IEC 60664-1)

Accessories

-

Dimensions

E1YF400V01 0.85
Voltage monitoring in 1-phase and 3-phase mains
UNDER Undervoltage monitoring

E1YF400VT01 0.85
Voltage monitoring in 1-phase and 3-phase mains
UNDER Undervoltage monitoring
T Integrated testswitch

E1YF

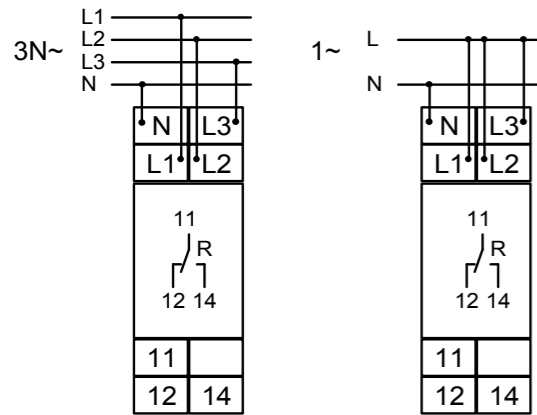

Width 17,5mm

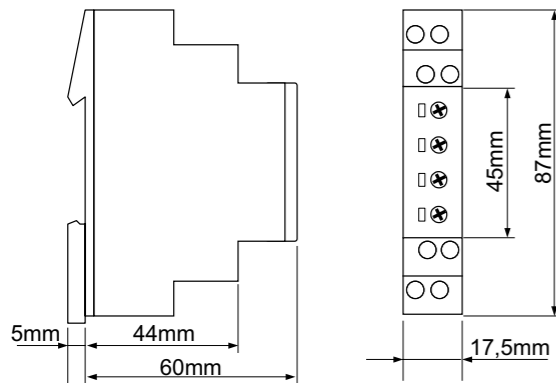

Functions



Sensing & Monitoring Relays Serie ENYA

Voltage monitoring in 3- and 1-phase mains

WatchDog



- Multifunction
- Monitoring of phase failure
- Monitoring of phase sequence selectable
- Connection of neutral wire optional
- Supply voltage = measuring voltage
- 1 CO contact; 2 CO contacts
- Width 17,5mm; 35mm
- Installation design

Connections

types

E3YM230VS20

E1YM400VS10

E1YM480Y/277VS10



Art.No. (PQ1)

1340406

1340405

1340409

Art.No. (PQ10)

-

-

-

EAN13-Code

9008662006393

900866200484

9008662006768

Measured variable

3(N)~
AC Sinus (48 bis 63Hz)

3(N)~
AC Sinus (48 bis 63Hz)

3(N)~
AC Sinus (48 bis 63Hz)

Measured range

$U_N = 230/132V$
terminals (N)-L1-L2-L3

$U_N = 400/230V$
terminals (N)-L1-L2-L3

$U_N = 480/277V$
terminals L1-L2-L3

Control

Delay • Max • Min • Function

Delay • max • min • Function

Delay • max • min • Function

Indicators (LEDs)

SEQ • Max • Min • R

SEQ • max • min • R

SEQ • max • min • R

Functions

UNDER
UNDER+SEQ
WIN
WIN+SEQ

UNDER
UNDER+SEQ
WIN
WIN+SEQ

UNDER
UNDER+SEQ
WIN
WIN+SEQ

Asymmetry

-

-

-

Switching threshold min.

80% to 130% of U_N

80% to 130% of U_N

75% to 110% of U_N

Switching threshold min.

70% to 120% of U_N

70% to 120% of U_N

65% to 100% of U_N

Hysteresis

-

-

-

Tripping delay

0 to 10s

0,1 to 10s

0,1 to 10s

Start-up delay time

-

-

-

Fault latch

-

-

-

Supply

= measuring voltage
3(N)~230/132V -30% to +30%
terminals (N)-L1-L2-L3

= measuring voltage
3(N)~400/230V -30% to +30%
terminals (N)-L1-L2-L3

= measuring voltage
3~480/277V -35% to +10%
terminals L1-L2-L3

Output

2 CO contacts
250V, 5A AC

1 CO contact
250V, 5A AC

1 CO contact
250V, 5A AC

Width

35mm

17,5mm

17,5mm

Certificates

CE • cULus • GOST

CE • cULus • GOST

CE • GOST

Mechanical design

Self-extinguishing plastic housing, IP rating IP40 • Mounted on DIN-Rail TS 35 in accordance with EN 60715 • Mounting position any • Shockproof terminal connection according to VBG 4 (PZ1 required), IP rating IP20 • Tightening torque max. 1Nm

Terminal capacity

1 x 0,5 to 2,5mm² with/without multicore cable end • 1 x 4mm² without multicore cable end • 2 x 0,5 to 1,5mm² with/without multicore cable end • 2 x 2,5mm² flexible without multicore cable end

Ambient conditions

Ambient temperature: -25 to +55°C (in accordance with IEC 60068-1) • Storage temperature: -25 to +70°C • Transport temperature: -25 to +70°C • relative humidity: 15% to 85% (in accordance with IEC 60721-3-3 class 3K3) • Pollution degree: 2 (in accordance with IEC 60664-1)

Accessories

-

E1YM, E3YM

Voltage monitoring in single-phase and 3-phase mains with adjustable thresholds, adjustable trip delay, monitoring of phase breakdown and phase sequence and the following functions that can be selected via rotary switches:

| | |
|-----------|--|
| UNDER | Undervoltage monitoring |
| UNDER+SEQ | Undervoltage and phase sequence monitoring |
| WIN | Window monitoring, monitoring of range between the min and max thresholds |
| WIN+SEQ | Monitoring the window between Min and Max and monitoring of phase sequence |

E3YM230VS20

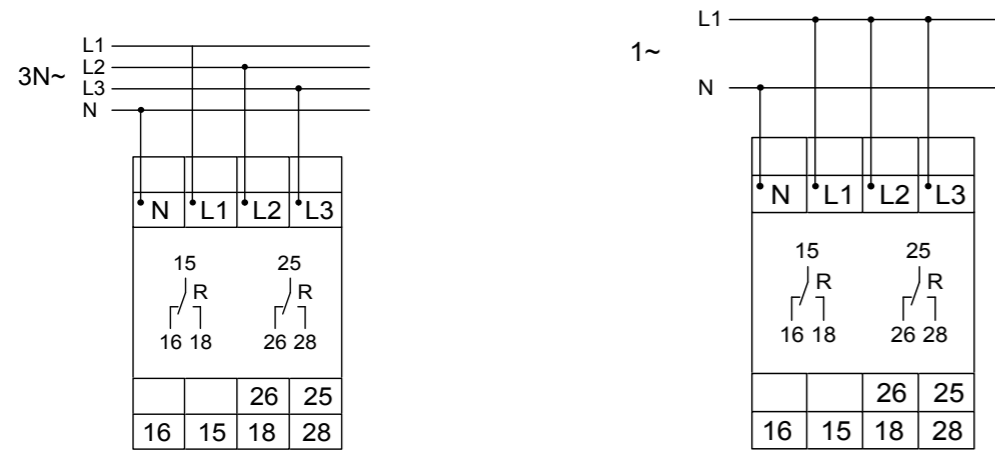

E1YM400VS10

E1YM480Y/277VS10

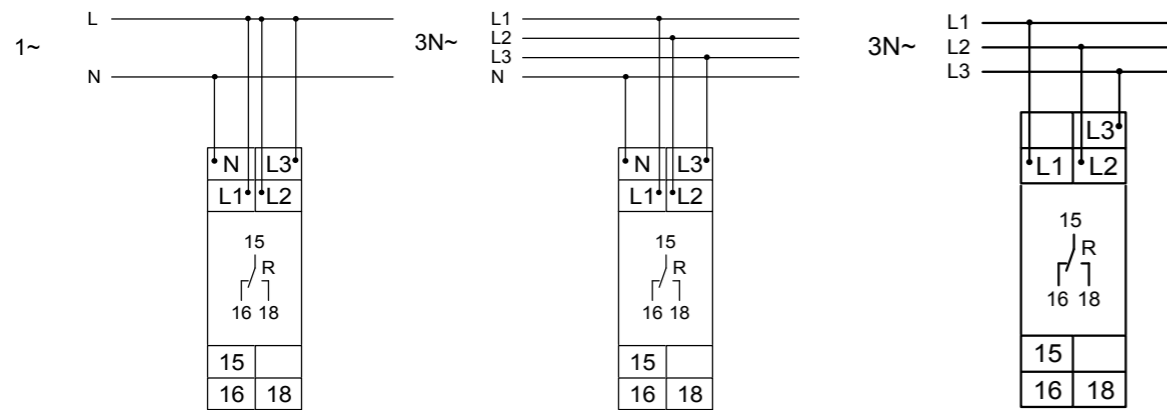

Width 17,5mm

Width 35mm

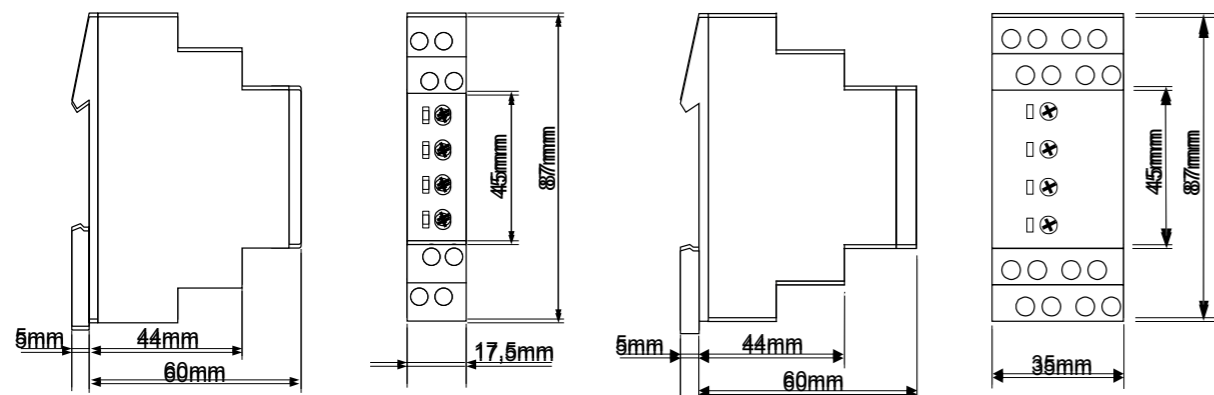

Functions



Sensing & Monitoring Relays Series ENYA

Voltage monitoring in 3- and 1-phase mains

WatchDog



- Undervoltage monitoring
- Supply voltage = measuring voltage
- 1 CO contact; 2 CO contacts
- Width 17,5mm; 35mm
- Installation design

Connections

types

E3YU400V02

E1YU400V01



Art.No. (PQ1)

1341403

1340403

Art.No. (PQ10)

-

-

EAN13-Code

9008662005617

900866200059

Measured variable

3(N)~
AC Sinus (48 to 63Hz)

3(N)~
AC Sinus (48 to 63Hz)

Measured range

$U_N = 400/230V$
terminals N-L1-L2-L3

$U_N = 400/230V$
terminals N-L1-L2-L3

Control

U_S

U_S

Indicators (LEDs)

L1 • L2 • L3 • R

L1 • L2 • L3 • R

Functions

UNDER

UNDER

Asymmetry

-

-

Switching threshold min.

160-240V (L-N)

160-240V (L-N)

Hysteresis

approx. 5%

approx. 5%

Tripping delay

fixed approx. 200ms

fixed, approx. 200ms

Start-up suppression time

-

-

Fault latch

-

-

Supply

= measuring voltage
3(N)~400/230V -30% to +10%
terminals (N)-L1-L2-L3

= measuring voltage
3(N)~400/230V -30% to +10%
terminals (N)-L1-L2-L3

Output

2 CO contacts
250V, 5A AC

1 CO contact
250V, 5A AC

Width

35mm

17,5mm

Certificates

CE • cULus • GOST

CE • cULus • GOST

Mechanical design

Self-extinguishing plastic housing, IP rating IP40 • Mounted on DIN-Rail TS 35 in accordance with EN 60715 • Mounting position any • Shockproof terminal connection according to VBG 4 (PZ1 required), IP rating IP20 • Tightening torque max. 1Nm

Terminal capacity

1 x 0,5 to 2,5mm² with/without multicore cable end • 1 x 4mm² without multicore cable end • 2 x 0,5 to 1,5mm² with/without multicore cable end • 2 x 2,5mm² flexible without multicore cable end

Ambient conditions

Ambient temperature: -25 to +55°C (in accordance with IEC 60068-1) • Storage temperature: -25 to +70°C • Transport temperature: -25 to +70°C • relative humidity: 15% to 85% (in accordance with IEC 60721-3-3 class 3K3) • Pollution degree: 2 (in accordance with IEC 60664-1)

Accessories

-

Dimensions

E1YU, E3YU

Undervoltage monitoring in 4-wire systems (each phase against neutral), with adjustable setpoint (E1YU) and with fixed hysteresis.

E3YU

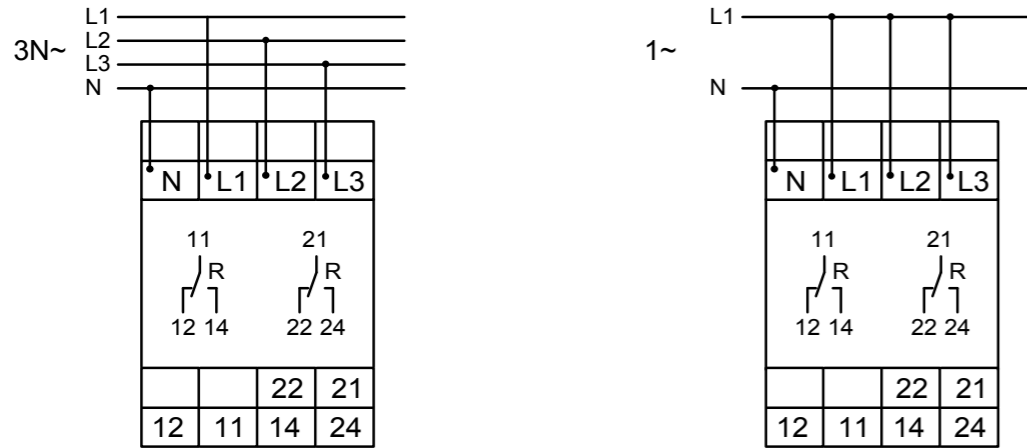

E1YU

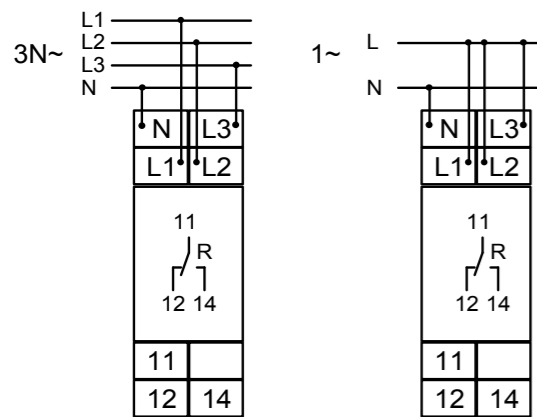

Width 17,5mm

Width 35mm

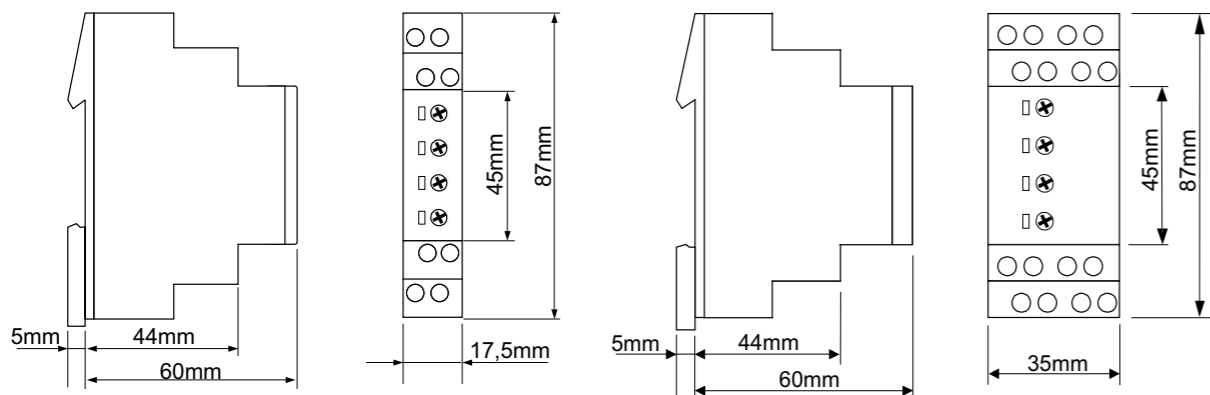

Functions



Sensing & Monitoring Relays Series ENYA

Voltage monitoring in 3- and 1-phase mains



- Voltage monitoring in accordance with VDE 0126-1-1
- Quick net error recognition
- Supply voltage = measuring voltage
- 2 CO contacts
- Width 35mm
- Installation design

Connections

types

E3YF400VFAL02



Art.No. (PQ1)

1341400

Art.No. (PQ10)

-

EAN13-Code

9008662005198

Measured variable

3(N)~
AC Sinus (48 to 63Hz)

Measured range

$U_N = 400/230V$
terminals (N)-L1-L2-L3

Control

Latch • Average

Indicators (LEDs)

U/t • R

Functions

WIN
WIN+LATCH

Asymmetry

-

Switching threshold min.

10-minute-average: +10% to +15% from U_N

Delay

$U \leq 80\%$ from U_N <200ms
 $U \geq 115\%$ from U_N <200ms
phase failure <20ms

On-delay

fixed 30s

Fault latch

selectable

Supply

= measuring voltage
3(N)~400/230V
terminals (N)-L1-L2-L3

Output

2 CO contacts
250V, 5A AC

Width

35mm

Certificates

CE • cULus • GOST

Mechanical design

Self-extinguishing plastic housing, IP rating IP40 • Mounted on DIN-Rail TS 35 in accordance with EN 60715 • Mounting position any • Shockproof terminal connection according to VBG 4 (PZ1 required), IP rating IP20 • Tightening torque max. 1Nm

Terminal capacity

1 x 0,5 to 2,5mm² with/without multicore cable end • 1 x 4mm² without multicore cable end • 2 x 0,5 to 1,5mm² with/without multicore cable end • 2 x 2,5mm² flexible without multicore cable end

Ambient conditions

Ambient temperature: -25 to +55°C (in accordance with IEC 60068-1) • Storage temperature: -25 to +70°C • Transport temperature: -25 to +70°C • relative humidity: 15% to 85% (in accordance with IEC 60721-3-3 class 3K3) • Pollution degree: 2, if built in 3 (in accordance with IEC 60664-1)

Accessories

-

E3YF400VFAL02

Voltage monitoring in 3-phase mains in accordance with VDE 0126-1-1 with fixed tripping delay, fixed threshold, adjustable 10-minute-average and selectable fault latch by means of rotary switch.

WIN Monitoring the fixed adjusted range
WIN+Latch Monitoring the fixed adjusted range with fault latch

E3YF400VFAL02

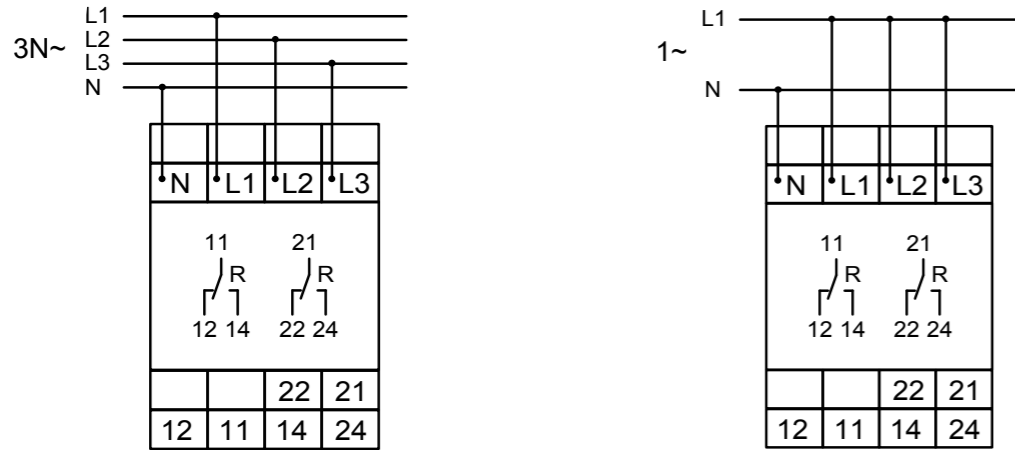

Width 35mm

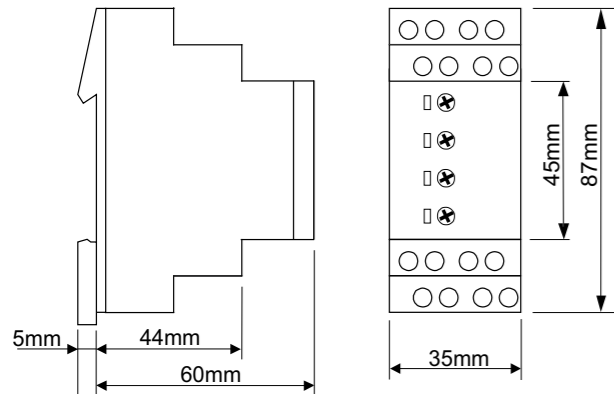

Functions



Sensing & Monitoring Relays Series ENYA

Voltage monitoring in 3- and 1-phase mains

WatchDog



- Monitoring of phase sequence, phase failure and asymmetry
- Connection of neutral wire optional (E1PF400VSY01, E3PF400VSY02)
- Supply voltage = measuring voltage
- 1 CO contact; 2 CO contacts
- Width 17,5mm or 35mm
- Installation design

Connections

types

E3PF400VSY02

E1PF400VSY01

E1PF480Y/277VSY10



Art.No. (PQ1)

1341300

1340300

1340305

Art.No. (PQ10)

-

-

-

EAN13-Code

900866200513

900866200486

-

Measured variable

3(N)~
AC Sinus (48 to 63Hz)

3(N)~
AC Sinus (48 to 63Hz)

3~
AC Sinus (48 to 63Hz)

Measured range

$U_N = 400/230V$
terminals (N)-L1-L2-L3

$U_N = 400/230V$
terminals (N)-L1-L2-L3

208V to 480V
terminals L1-L2-L3

Control

ASYM

ASYM

Delay • ASYM

Indicators (LEDs)

U • R

U • R

U • Failure • R

Functions

Monitoring of phase sequence, phase failure and asymmetry

Monitoring of phase sequence, phase failure and asymmetry

Monitoring of phase sequence, phase failure and asymmetry

Asymmetry

5% to 25%, OFF

5% to 25%; OFF

5% to 25%, OFF

Switching threshold max.

-

-

-

Switching threshold min.

-

-

-

Hysteresis

-

-

-

Tripping delay

fixed, approx. 100ms

fixed, approx. 100ms

0,1s to 20s

Start-up suppression time

-

-

-

Fault latch

-

-

-

Supply

= measuring voltage
3(N)~400/230V -30% to +30%
terminals (N)-L1-L2-L3

= measuring voltage
3(N)~400/230V -30% to +30%
terminals (N)-L1-L2-L3

= measuring voltage
3~208/120V to 480/277V
-10% to +10% from U_N
terminals L1-L2-L3

Output

2 CO contacts
250V, 5AAC

1 CO contact
250V, 5AAC

1 CO contact
250V, 5AAC

Width

35mm

17,5mm

17,5mm

Certificates

CE • cULus • GOST

CE • cULus • GOST

CE • cULus • GOST

Mechanical design

Self-extinguishing plastic housing, IP rating IP40 • Mounted on DIN-Rail TS 35 in accordance with EN 60715 • Mounting position any • Shockproof terminal connection according to VBG 4 (PZ1 required), IP rating IP20 • Tightening torque max. 1Nm

Terminal capacity

1 x 0,5 to 2,5mm² with/without multicore cable end • 1 x 4mm² without multicore cable end • 2 x 0,5 to 1,5mm² with/without multicore cable end • 2 x 2,5mm² flexible without multicore cable end

Ambient conditions

Ambient temperature: -25 to +55°C (in accordance with IEC 60068-1) • Storage temperature: -25 to +70°C • Transport temperature: -25 to +70°C • relative humidity: 15% to 85% (in accordance with IEC 60721-3-3 class 3K3) • Pollution degree: 2, if built in 3 (in accordance with IEC 60664-1)

Accessories

-

Dimensions

E1PF; E3PF

Monitoring of phase sequence, phase failure and asymmetry with adjustable asymmetry, connection of neutral wire optional.

E1PF400VSY01

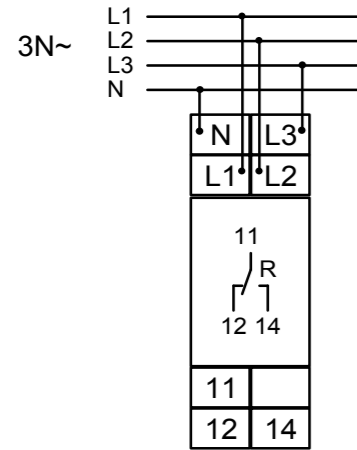

E3PF400VSY02

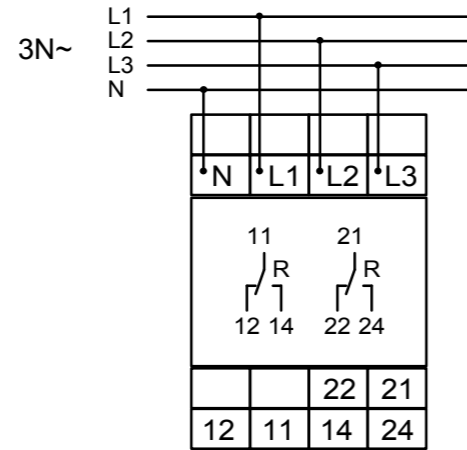

E1PF480Y/277VSY10

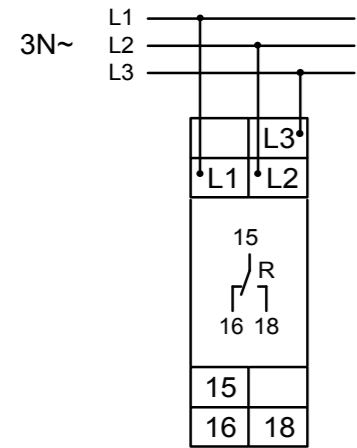

Width 17,5mm

Width 35mm

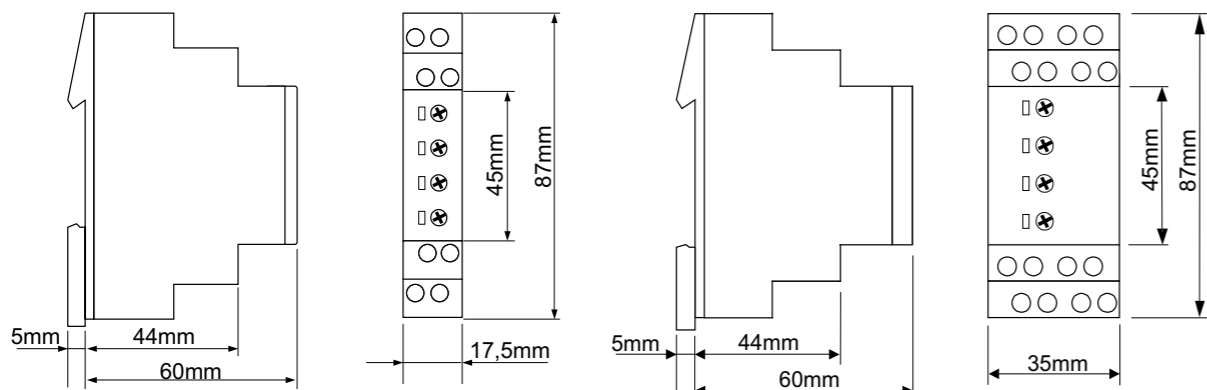

Functions



Sensing & Monitoring Relays Series ENYA

Voltage monitoring in 1-phase mains

WatchDog



- AC/DC voltage monitoring in 1-phase mains
- Multifunction (E1UM)
- Undervoltage monitoring (E1UU)
- Supply voltage = measuring voltage
- 1 CO contact
- Width 17,5mm
- Installation design

Connections

types

E1UM230V01

E1UU230V01



Art.No. (PQ1)

1340101

1340102

Art.No. (PQ10)

-

-

EAN13-Code

900866200510

900866200505

Measured variable

Voltage AC/DC
AC Sinus (48 to 63Hz)

Voltage AC/DC
AC Sinus (48 to 63Hz)

Measuring ranges

24V DC; terminals E-F1(+)
24V AC; terminals E-F2
230V AC; terminals E-F3

24V DC; terminals E-F1(+)
24V AC; terminals E-F2
230V AC; terminals E-F3

Controls

Max • Min • Function

Min

Indicators (LEDs)

U • Max • Min • R

U • R

Functions

UNDER
WIN

UNDER

Switching threshold max.

80% to 120% from U_N

-

Switching threshold min.

75% to 115% from U_N

75% to 115% from U_N

Hysteresis

adjustable

fixed 5%

Tripping delay

-

-

Start-up suppression time

-

-

Fault latch

-

-

Supply

= measuring voltage
24V DC; terminals E-F1(+)
24V AC; terminals E-F2
230V AC; terminals E-F3
-25% to +20%

= measuring voltage
24V DC; terminals E-F1(+)
24V AC; terminals E-F2
230V AC; terminals E-F3
-25% to +20%

Output

1 CO contact
250V, 5A AC

1 CO contact
250V, 5A AC

Width

17,5mm

17,5mm

Certificates

CE • cULus • GOST

CE • cULus • GOST

Mechanical design

Self-extinguishing plastic housing, IP rating IP40 • Mounted on DIN-Rail TS 35 in accordance with EN 60715 • Mounting position any • Shockproof terminal connection according to VBG 4 (PZ1 required), IP rating IP20 • Tightening torque max. 1Nm

Terminal capacity

1 x 0,5 to 2,5mm² with/without multicore cable end • 1 x 4mm² without multicore cable end • 2 x 0,5 to 1,5mm² with/without multicore cable end • 2 x 2,5mm² flexible without multicore cable end

Ambient conditions

Ambient temperature: -25 to +55°C (in accordance with IEC 60068-1) • Storage temperature: -25 to +70°C • Transport temperature: -25 to +70°C • relative humidity: 15% to 85% (in accordance with IEC 60721-3-3 class 3K3) • Pollution degree: 2 (in accordance with IEC 60664-1)

Accessories

-

E1UM

AC/DC voltage monitoring in 1-phase mains with adjustable thresholds and hysteresis.

UNDER Undervoltage monitoring
 WIN Monitoring the window between Min and Max

E1UU

AC/DC UNDERvoltage monitoring in 1-phase mains with adjustable threshold and fixed hysteresis.

UNDER Undervoltage monitoring

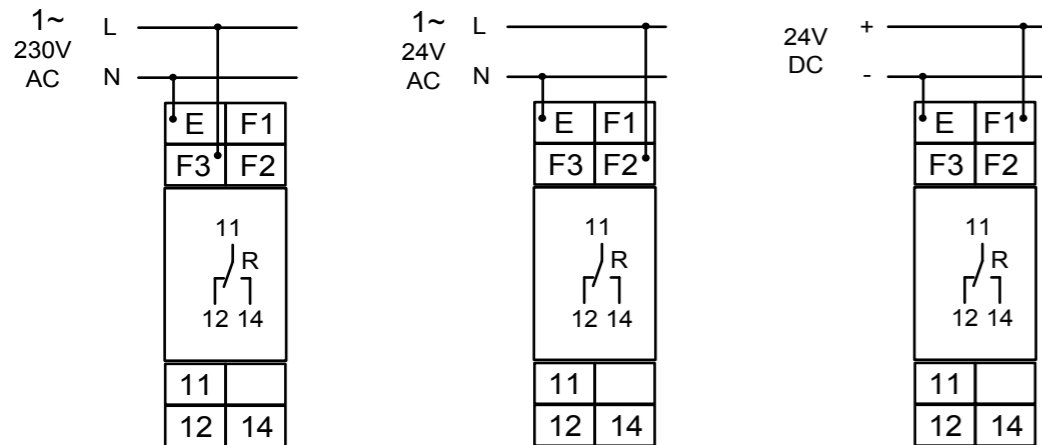
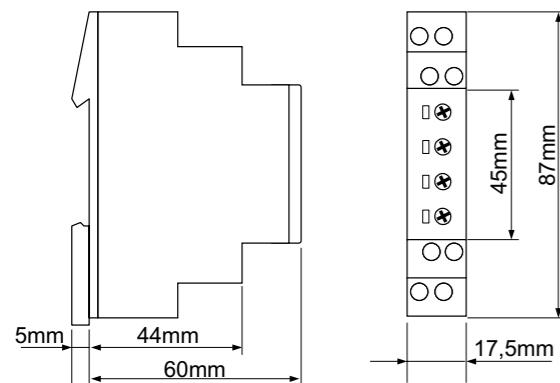
E1UM; E1UU**Width 17,5mm****Functions**

- AC/DC current monitoring (E3IM)
- AC current monitoring (E1IM; E1IU)
- Multifunction (E1IM; E3IM)
- Undercurrent monitoring (E1IU)
- Supply voltage 230V (E3IM - galvanically separated)
- 1 CO contact; 2 CO contacts
- Width 17,5mm; 35mm
- Installation design

Connections

types

E3IM10AL20

E1IM10AACL10

E1IU5AAC01

E1IU500mAAC01

Art.No. (PQ1)

1341200

1340200

1340201

1340204

Art.No. (PQ10)

-

-

-

-

EAN13-Code

900866200594

900866200486

900866200504

9008662005341

Measured variable

Current
 AC/DC Sinus (16 to 400Hz)
 100mA AC/DC; terminals k-11
 1A AC/DC; terminals k-12
 10A AC/DC; terminals k-13

Current
 AC Sinus (48 to 63Hz)
 10A AC; terminals Li-Lk

Current
 AC Sinus (48 to 63Hz)
 5A AC; terminals Li-Lk

Current
 AC Sinus (48 to 63Hz)
 500mA AC; terminals Li-Lk

Measuring ranges

Controls

Start • Max • Min • Function • Delay

Delay • Max • Min • Function

 I_s I_s

Indicators (LEDs)

U/t • Max • Min • R

U/t • Max • Min • R

U • R

U • R

Functions

OVER
 OVER+LATCH
 UNDER
 UNDER+LATCH
 WIN
 WIN+LATCH

OVER
 OVER+LATCH
 UNDER
 UNDER+LATCH
 WIN
 WIN+LATCH

UNDER

UNDER

Switching threshold max.

10% to 100% of I_N 10% to 100% of I_N

-

-

Switching threshold min.

5% to 95% of I_N 5% to 95% of I_N 10% to 100% of I_N 10% to 100% of I_N

Hysteresis

adjustable

adjustable

fixed, 10%

fixed, 10%

Tripping delay

0,1s to 10s

0,1s to 10s

-

-

Start-up suppression time

0s to 10s

-

-

-

Fault latch

selectable

selectable

-

-

Supply

230V AC
 terminals A1-A2
 -15% to +15%

230V AC
 terminals Li-N
 -15% to +15%

230V AC
 terminals Li-N
 -15% to +15%

230V AC
 terminals Li-N
 -15% to +15%

Output

2 CO contacts
 250V, 5A AC

1 CO contact
 250V, 5A AC

1 CO contact
 250V, 5A AC

1 CO contact
 250V, 5A AC

Width

35mm

17,5mm

17,5mm

17,5mm

Certificates

CE

CE • cULus • GOST

CE • cULus • GOST

CE • cULus • GOST

Mechanical design

Self-extinguishing plastic housing, IP rating IP40 • Mounted on DIN-Rail TS 35 in accordance with EN 60715 • Mounting position any • Shockproof terminal connection according to VBG 4 (PZ1 required), IP rating IP20 • Tightening torque max. 1Nm

Terminal capacity

1 x 0,5 to 2,5mm² with/without multicore cable end • 1 x 4mm² without multicore cable end • 2 x 0,5 to 1,5mm² with/without multicore cable end • 2 x 2,5mm² flexible without multicore cable end

Ambient conditions

Ambient temperature: -25 to +55°C (in accordance with IEC 60068-1) • Storage temperature: -25 to +70°C • Transport temperature: -25 to +70°C • relative humidity: 15% to 85% (in accordance with IEC 60721-3-3 class 3K3) • Pollution degree: 2 (in accordance with IEC 60664-1)

Accessories

Mounting plate MP; Current transformer Series DSW and WSW

E11M: DC current monitoring with adjustable thresholds, hysteresis and tripping delay.
E31M: AC/DC current monitoring with adjustable thresholds, hysteresis and tripping delay.

OVER Overcurrent monitoring
 UNDER Undercurrent monitoring
 WIN Monitoring the window between Min and Max
 OVER+Latch Overcurrent monitoring with fault latch
 UNDER+Latch Undercurrent monitoring with fault latch
 WIN+Latch Monitoring the window between Min and Max with fault latch

E11U
 AC current monitoring with adjustable threshold and fixed hysteresis.

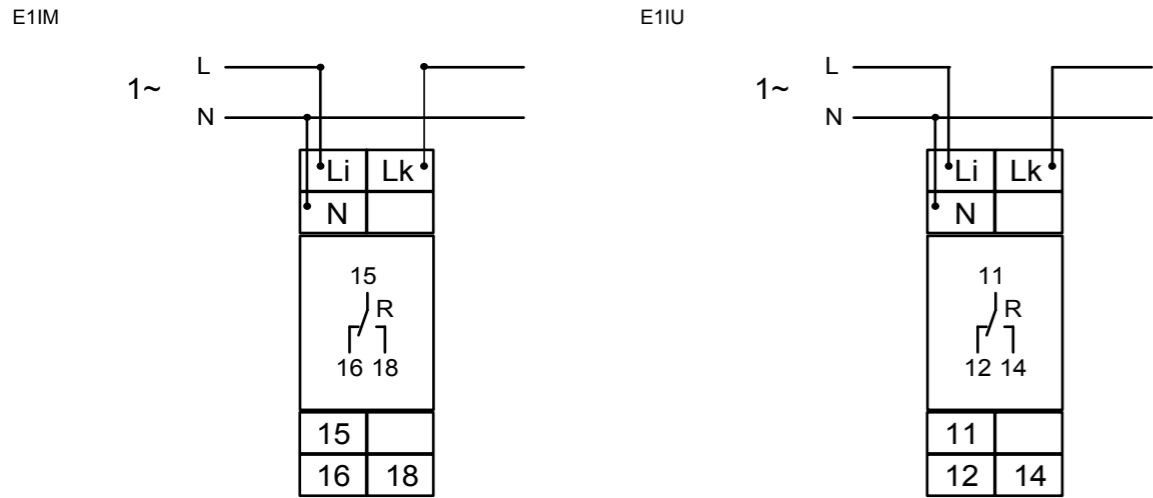

E31M measuring range 100mA; 1A; 10A

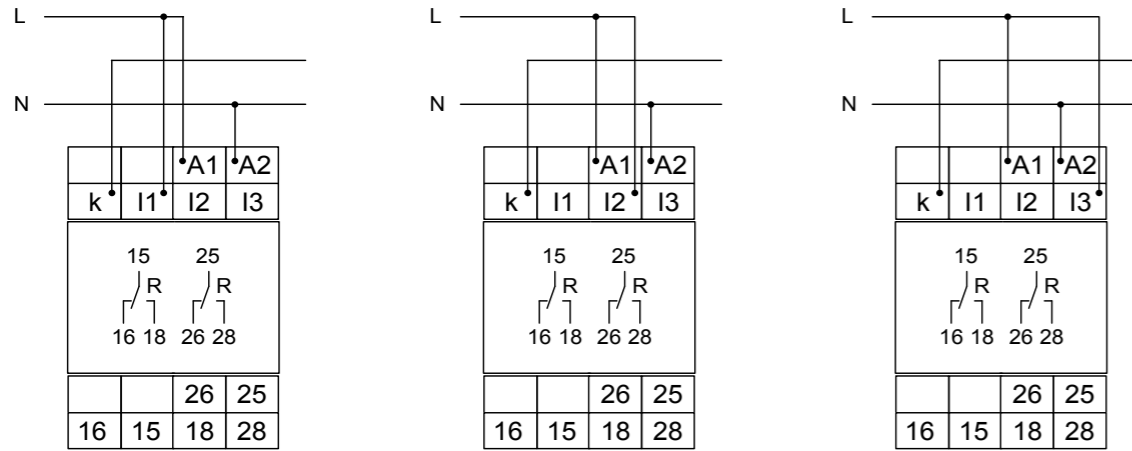

Width 17,5mm

Width 35mm

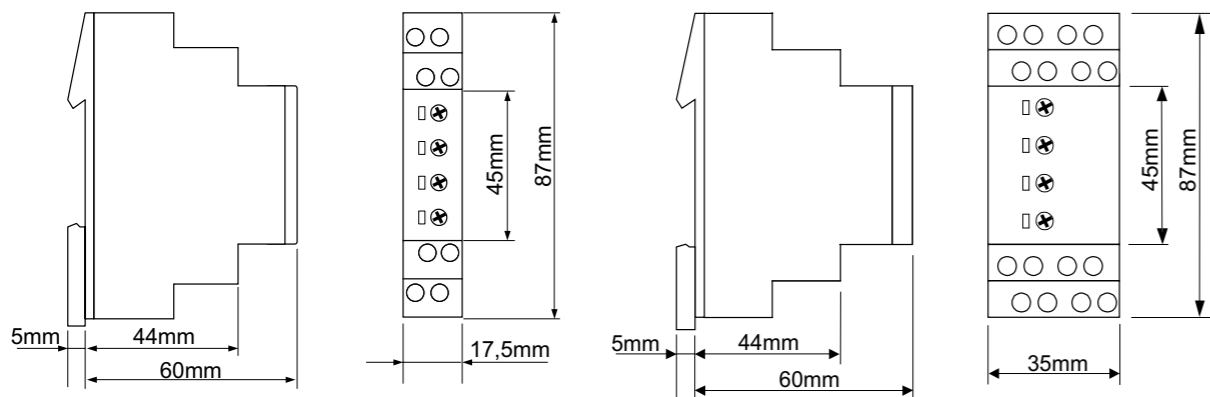

Functions



Sensing & Monitoring Relays Series ENYA



Temperature monitoring

- Temperature monitoring of the motor winding for temperature sensors in accordance with DIN 44081
- Maximum 6 PTC sensors
- Short circuit monitoring of the thermistor line (selectable by means of terminals)
- Optional evaluation of one thermal contact
- Test function with integrated reset key
- Rated isolated voltage on the sensor circuit up to 690V
- 1 CO contact
- Width 35mm
- Installation design

Connections

types

E3TF01



Art.No. (PQ1)

1341600

Art.No. (PQ10)

-

EAN13-Code

900866200512

Measured variable

PTC (motortemperature)

max. 6 PTC probes

Measured range

total resistance cold <1,5kΩ
 terminals T1-T2 or T1-T3

Measuring voltage

≤7,5V DC by R ≤4,0kΩ
 (in accordance with EN 60947-8)

Controls

Test/Reset button

Indicators (LEDs)

U • Failure

Functions

Overtemperature

Response value

≥3,6kΩ

Release value

≤1,65kΩ

Short circuit monitoring

<20Ω

Fault latch

yes

Reset

internal or external
 terminals R1-R2

Supply

230V AC
 terminals A1-A2

Output

1 CO contacts
 250V, 5A AC

Width

35mm

Certificates

CE • cULus • GOST

Mechanical design

Self-extinguishing plastic housing, IP rating IP40 • Mounted on DIN-Rail TS 35 in accordance with EN 60715 • Mounting position any • Shockproof terminal connection according to VBG 4 (PZ1 required), IP rating IP20 • Tightening torque max. 1Nm

Terminal capacity

1 x 0,5 to 2,5mm² with/without multicore cable end • 1 x 4mm² without multicore cable end • 2 x 0,5 to 1,5mm² with/without multicore cable end • 2 x 2,5mm² flexible without multicore cable end

Ambient conditions

Ambient temperature: -25 to +55°C (in accordance with IEC 60068-1) • Storage temperature: -25 to +70°C • Transport temperature: -25 to +70°C • relative humidity: 15% to 85% (in accordance with IEC 60721-3-3 class 3K3) • Pollution degree: 2 (in accordance with IEC 60664-1)

Accessories

-

Dimensions

E3TF01
 Temperature monitoring of the motor winding (max. 6 PTC) with fault latch for temperature sensors in accordance with DIN 44081, short circuit monitoring of the thermistor line (selectable by means of terminals), integrated test/reset key.

Note:
 Only one of this circuit versions (either monitoring of the temperature sensor or monitoring of the thermal contact) can be executed.

Monitoring Temperature sensor

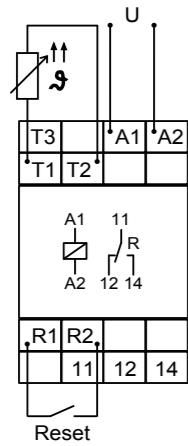

Monitoring Thermal contact

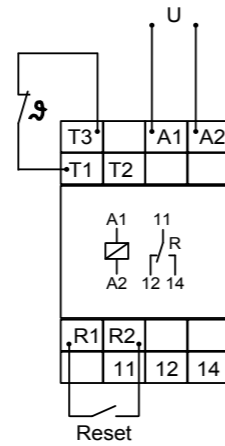

Width 35mm

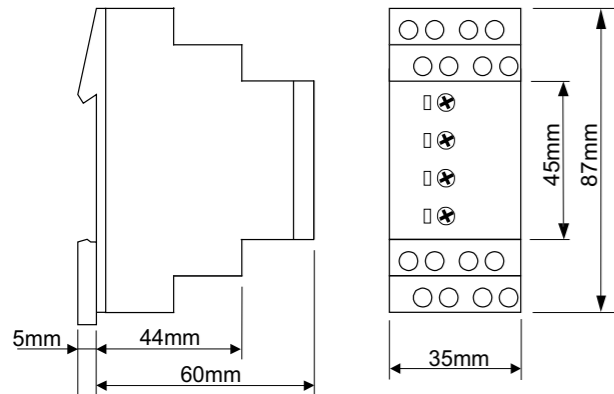

Functions



Sensing & Monitoring Relays Series ENYA



Level monitoring

- Level monitoring of conductive liquids
- Multifunction
- Reinforced insulation of the measuring circuit
- 1 CO contact
- Width 35mm
- Installation design

Connections

types

E3LM10



| | |
|--------------------|--|
| Art.No. (PQ1) | 1341500 |
| Art.No. (PQ10) | - |
| EAN13-Code | 900866200509 |
| Measured variable | level with conductive probe |
| Measured range | 0,25 to 100kΩ |
| Probe voltage | 12V AC |
| Probe current | max. 7mA |
| Wiring distance | max. 1000m (adjustment <50%) max. 100m (adjustment <100%) capacity of cable 100nF/km |
| Control | Delay ON • Delay OFF • Sensitivity • Function |
| Indicators (LEDs) | U • R |
| Functions | Pump up Pump down |
| trigger level | 0,25 to 100 kΩ (Sensitivity) |
| Tripping delay | 0,5s to 10s |
| Turn-off delay | 0,5s to 10s |
| Supply | 230V AC terminals A1-A2 |
| Output | 1 CO contact 250V, 5A AC |
| Width | 35mm |
| Certificates | CE • cULus • GOST |
| Mechanical design | Self-extinguishing plastic housing, IP rating IP40 • Mounted on DIN-Rail TS 35 in accordance with EN 60715 • Mounting position any • Shockproof terminal connection according to VBG 4 (PZ1 required), IP rating IP20 • Tightening torque max. 1Nm |
| Terminal capacity | 1 x 0,5 to 2,5mm ² with/without multicore cable end • 1 x 4mm ² without multicore cable end • 2 x 0,5 to 1,5mm ² with/without multicore cable end • 2 x 2,5mm ² flexible without multicore cable end |
| Ambient conditions | Ambient temperature: -25 to +55°C (in accordance with IEC 60068-1) • Storage temperature: -25 to +70°C • Transport temperature: -25 to +70°C • relative humidity: 15% to 85% (in accordance with IEC 60721-3-3 class 3K3) • Pollution degree: 2 (in accordance with IEC 60664-1) |
| Accessories | Conductive probes (types SK1, SK2, SK3) |

Dimensions

E3LM10

Level monitoring of conductive liquid, timing for tripping delay and turn-off delay separately adjustable and the following functions (selectable by means of rotary switch):

| | |
|-----------|---------------------------------|
| Pump up | pump up or minimum monitoring |
| Pump down | pump down or maximum monitoring |

Functions

E3LM

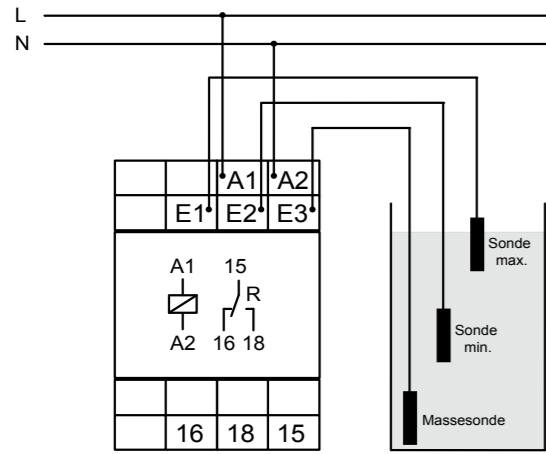

Connections

With 35mm

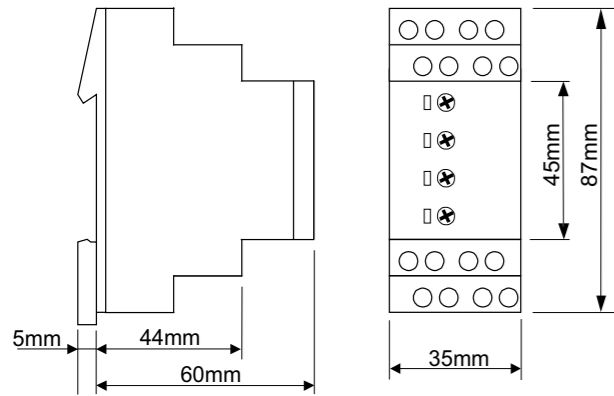

Dimensions

LOAD-MONITOR



“The motor as sensor”: Monitoring motors' efficiency or effective power makes it possible to draw a number of useful conclusions regarding the state of drives, machines and installations, and this can often be used to reduce the cost of maintenance, servicing and downtime. TELE offers the widest range of products with the following performance features:

- Measurement of one or more quantities such as power factor ($\cos \varphi$) and effective power
- Measuring voltages in conventional mains grids at 230/400 V or 240/415 V as well as special industrial power supplies at 400/690 V
- Single-phase and three-phase loads
- Direct measurement of up to 16 amps with no scaling components

The robust design with generous terminal space throughout plus facilities for taking measurements downstream from frequency converters together ensure very good usability and installability.

OVERVIEW

Seite

Selection matrix Quick, explicit and time-saving to the right product. 88

Industry Series: GAMMA

- True power monitoring 89
- Active power transducer 97
- Active current transducer 99
- Power factor monitoring 101



SERIES Design



GAMMA
Industrie

True power monitors

Current

COSφ - Monitors

| Function | True power monitors | | | | | | | | | | Current | COSφ - Monitors | | |
|---|---------------------|----------------|------------------|--------------------------------|-----------------|------------------|-----------------|----------------|-----------------|-----------------|-----------------|-----------------|-----------------|----------------|
| Underload detection | ■ | ■ | ■ | ■ | ■ | ■ | ■ | ■ | ■ | ■ ⁵⁾ | ■ ⁵⁾ | ■ | ■ | ■ |
| Overload detection | ■ | ■ | ■ | ■ | ■ | ■ | ■ | ■ | ■ | ■ ⁵⁾ | ■ ⁵⁾ | ■ ¹⁾ | ■ ¹⁾ | |
| Under- and overload detection (Window) | ■ | ■ | ■ | ■ | ■ | ■ | | | | ■ ⁵⁾ | ■ ⁵⁾ | ■ ¹⁾ | ■ ¹⁾ | |
| I=0 (zero current-) detection ²⁾ | ■ | ■ | ■ | ■ | ■ | ■ | ■ | ■ | ■ | | | ■ | ■ | ■ |
| Temperature monitoring for motor windings | ■ | | ■ | ■ | ■ | ■ | | | | | | | | |
| Configurable threshold | ■ | ■ | ■ | ■ | ■ | ■ | ■ | ■ | ■ | ■ ⁵⁾ | ■ ⁵⁾ | ■ | ■ | ■ |
| Configurable hysteresis ³⁾ | | | ■ | ■ | | | | | | ■ ⁵⁾ | ■ ⁵⁾ | ■ | ■ | |
| Fault storage | ■ | ■ | ■ | ■ | ■ | ■ | ■ | ■ | ■ | ■ ⁵⁾ | ■ ⁵⁾ | ■ | ■ | ■ |
| Override on start-up ⁴⁾ | ■ | ■ | ■ | ■ | ■ | ■ | ■ | ■ | ■ | ■ ⁵⁾ | ■ ⁵⁾ | ■ | ■ | ■ |
| Tripping delay | ■ | ■ | ■ | ■ | ■ | ■ | ■ | ■ | ■ | ■ ⁵⁾ | ■ ⁵⁾ | ■ | ■ | ■ |
| Reduced tripping times | | | | | | ■ | ■ | | ■ | | | | | |
| Digital control | | | ■ | ■ | | | | | | | | | | |
| Outputs | | | | | | | | | | | | | | |
| 1 CO contact | | | | | | | | ■ | ■ | ■ | | | | ■ |
| 2 CO contacts | ■ | ■ | ■ | ■ | ■ | ■ | | | | | | ■ | ■ | |
| Current rating | 16A | 16A | 12A | 12A | 12A | 12A | 12A | 12A | 12A | 12A | 15A | 10A | 2A | 10A |
| Analogue output | | | | | | | | | | 4-20mA | 4-20mA | | | |
| Measured voltage | | | | | | | | | | | | | | |
| | 400/690V AC | 400/690V AC | 277/480V AC | 277/480V AC | 277/480V AC | 277/480V AC | 277/480V AC | 230/400V AC | 277/480V AC | 277/480V AC | - | 230/400V AC | 230/400V AC | 230/400V AC |
| Mains voltage | | | | | | | | | | | | | | |
| | 12 - 500V AC | 12 - 500V AC | 12 - 500V AC | 24 - 240V AC/DC | 12 - 500V AC | 12 - 500V AC | 12 - 400V AC | 12 - 400V AC | 12 - 400V AC | 24 - 240V AC/DC | 24 - 240V AC/DC | 12 - 400V AC | 12 - 400V AC | 12 - 400V AC |
| Type | | | | | | | | | | | | | | |
| | G4BM690V16ATL20 | G4BM690V16AL20 | G4BM480V12ADTL20 | G4BM480V12ADTL20 24-240V AC/DC | G4BM480V12ATL20 | G4BM480V12AFTL20 | G2BM480V12AFL10 | G2BM400V12AL10 | G2BM480V12AFL10 | G2BA480V12A | G2IA15A | G2CM400V10AL20 | G2CM400V2AL20 | G2CU400V10AL10 |
| Technical data page | 89 | 89 | 91 | 91 | 93 | 93 | 95 | 95 | 95 | 97 | 99 | 101 | 101 | 101 |

1) Due to cos φ characteristics maximum detection is only possible within underload range of the motor.
 2) Optional detection of disconnected load. A standby condition of the monitoring relay will be triggered.
 3) For two-point controller, the differential gap (hysteresis) can be set separately. It's the difference between the upper and lower threshold.
 4) Time function which disables an error message during start up; this enables a start-up without shut off from inrush load.
 5) Monitoring and controlling functions via PLC.



Loadmonitors Series GAMMA

Effective power recording for 1 or 3 phase loads



- Multifunction
- Temperature monitoring of the motor coil (G4BM690V16ATL20)
- Fault memory; reset button
- Detection of shorted loads I=0
- Frequency converter suitable (10 to 100Hz)
- Supply voltage selectable via power module
- 2 CO contacts
- Width 45mm
- Industrial design

types

G4BM690V16ATL20

G4BM690V16AL20



| | | |
|----------------------------|--|--|
| Art.No. (PQ1) | 2394720 | 2394721 |
| Art.No. (PQ10) | - | - |
| EAN13-Code | | |
| Measured variable | True power consumption 1- or 3-phase Loads AC Sinus (10 to 400Hz) | True power consumption 1- or 3-phase Loads AC Sinus (10 to 400Hz) |
| Measuring range | 2kW • 4kW • 8kW • 16kW | 2kW • 4kW • 8kW • 16kW |
| Measuring voltage | 1-Phase loads: 42 to 690V AC 3-Phase loads: 3~ 42 to 690/400V | 1-Phase loads: 42 to 690V AC 3-Phase loads: 3~ 42 to 690/400V |
| Measuring range Current | Measuring range 2 and 4kW: 0,2 to 8A Measuring range 8 and 16kW: 0,4 to 16A | Measuring range 2 and 4kW: 0,2 to 8A Measuring range 8 and 16kW: 0,4 to 16A |
| Controls | Start • P1 • Delay • Range • Function • I < P2 • Reset | Start • P1 • Delay • Range • Function • I < P2 • Reset |
| Indicators (LEDs) | U/t • Failure P1 • Rel1 • I=0 • Failure P2 • Temp • Rel2 | U/t • Failure P1 • Rel1 • I=0 • Failure P2 • Rel2 |
| Functions | 2MAX 2MIN WIN MIN/MAX I=0 with optionally selectable relay setting | 2MAX 2MIN WIN MIN/MAX I=0 with optionally selectable relay setting |
| Threshold Th_A and Th_B | P1: 10% to 120% from P_N P2: 5% to 110% from P_N | P1: 10% to 120% from P_N P2: 5% to 110% from P_N |
| Hysteresis | fixed, ca. 3% from P_N | fixed, ca. 3% from P_N |
| Triggering delay | 0,1s to 50s | 0,1s to 50s |
| Start-up suppression time | 1s to 100s | 1s to 100s |
| Fault latch | Wire link Y1-Y2 | Wire link Y1-Y2 |
| Supply | PowerModule TR3 (12 - 500V AC) Terminals A1-A2 | PowerModule TR3 (12 - 500V AC) Terminals A1-A2 |
| Output | 2 CO contact 250V 5A AC | 2 CO contact 250V 5A AC |
| Width | 45mm | 45mm |
| Certificates | CE • GOST | CE • GOST |
| Mechanical design | Self-extinguishing plastic housing, IP rating IP40 • Mounted on DIN-Rail TS 35 in accordance with EN 60715 • Mounting position any • Shockproof terminal connection according to VBG 4 (PZ1 required), IP rating IP20 • Tightening torque max. 1Nm | |
| Terminal capacity | 1 x 0,5 to 2,5mm ² with/without multicore cable end • 1 x 4mm ² without multicore cable end • 2 x 0,5 to 1,5mm ² with/without multicore cable end • 2 x 2,5mm ² flexible without multicore cable end | |
| Ambient conditions | Ambient temperature: -25 to 55°C (in accordance with IEC 60068-1); -25 to 40°C (in accordance with UL 508) • Storage temperature: -25 to +70°C • Transport temperature: -25 to +70°C • relative humidity: 15% to 85% (in accordance with IEC 60721-3-3 class 3K3) • Pollution degree: 3 (in accordance with IEC 60664-1) • Vibration resistance: 10 to 55Hz 0,35mm (in accordance with IEC 60068-2-6) • Shock resistance: 15g 11ms (in accordance with IEC 60068-2-27) | |
| Accessories | PowerModules TR3 (12 - 500V AC) • sealable intervention protection shield FA-G2 | |

2MIN Underload monitoring for two independent thresholds
 2MAX Underload monitoring for two independent thresholds
 WIN Monitoring of the threshold level between min and max areas
 MIN/MAX Underload and overload monitoring for two independent thresholds

I< Detection of shorted loads with selectable relay setting

Connected 3~ 230/400V with power module 230V AC with fault latch and temperature monitoring sensor $I_N < 16A$

Connected 3~ 400/690V with power module 24V AC without fault latch $I_N < 16A$

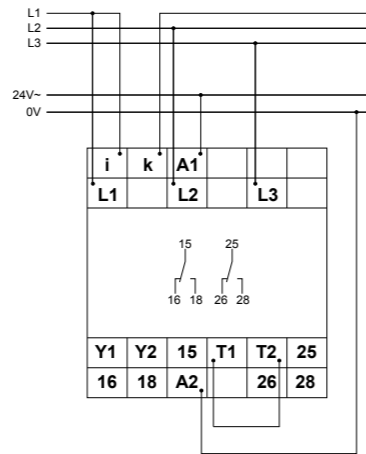
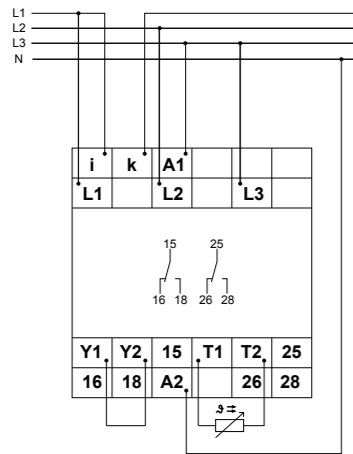

Connected 3~ 400/690V with power module 400V AC with fault latch and current transformer $I_N > 16A$

Connected 3~ 500V with power module 500V AC with fault latch $I_N < 16A$

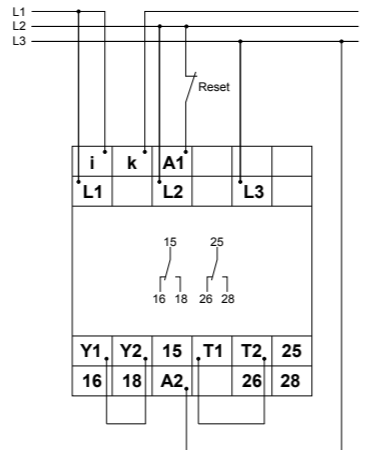
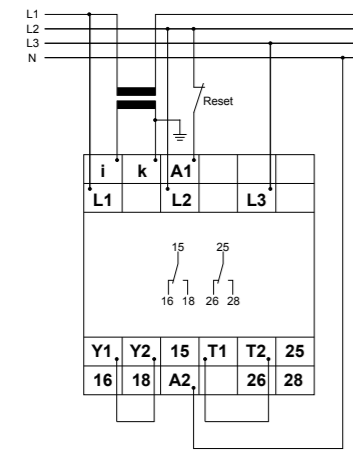

Width 45mm

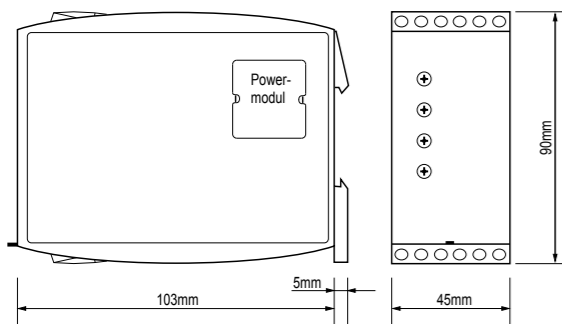

Functions



- Multifunction
- Digital setting
- Temperature monitoring of the motor coil
- Fault latch
- Recognition of disconnected load I=0
- Suitable for VFI (10 to 100Hz)
- Supply voltage selectable via power modules or zoom voltage 24-240V AC/DC
- 2 CO contact
- Width 45mm
- Industrial design

Connections

types

G4BM480V12ADTL20

G4BM480V12ADTL20 24-240V



Art.No. (PQ1)

2394700

2394706

Art.No. (PQ10)

-

-

EAN13-Code

9008662006072

-

Measured variable

True power consumption 1- or 3-phase Loads
AC Sinus (10 to 400Hz)

True power consumption 1- or 3-phase Loads
AC Sinus (10 to 400Hz)

Measuring range

2,5kW and 10kW

2,5kW and 10kW

Measuring voltage

1-Phase loads: 0 to 480VAC
3-Phase loads: 3~ 0 to 480/277V

1-Phase loads: 0 to 480VAC
3-Phase loads: 3~ 0 to 480/277V

Measuring range Current

Measuring ranges 2,5kW: 0,15 to 6A
Measuring ranges 10kW: 0,3 to 12A

Measuring ranges 2,5kW: 0,15 to 6A
Measuring ranges 10kW: 0,3 to 12A

Controls

Programming buttons

Programming buttons

Indicators (LEDs)

Display

Display

Functions

OVER • OVER+I=0 ON • UNDER • UNDER+I=0 ON
2MIN • 2MIN+I=0 ON • 2MAX • 2MAX+I=0 ON
WIN • WIN+I=0 ON • MIN/MAX • MIN/MAX+I=0 ON

OVER • OVER+I=0 ON • UNDER • UNDER+I=0 ON
2MIN • 2MIN+I=0 ON • 2MAX • 2MAX+I=0 ON
WIN • WIN+I=0 ON • MIN/MAX • MIN/MAX+I=0 ON

Threshold

Th_A and Th_B
Measuring ranges 2,5kW: 120W to 2490W
Measuring ranges 10kW: 480W to 9960W

Measuring ranges 2,5kW: 120W to 2490W
Measuring ranges 10kW: 480W to 9960W

Hysteresis

fixed 5% or adjustable

fixed 5% or adjustable

Triggering delay

0,1s to 50s

0,1s to 50s

Start-up suppression time

0s to 100s

0s to 100s

Fault latch

Wire link Y1-Y2

Wire link Y1-Y2

Supply

PowerModule TR3 (12 - 500V AC)
Terminals A1-A2

24-240V AC/DC
Terminals A1-A2

Output

2 CO contact
250V 5A AC

2 CO contact
250V 5A AC

Width

45mm

45mm

Certificates

CE • GOST

CE • GOST

Mechanical design

Self-extinguishing plastic housing, IP rating IP40 • Mounted on DIN-Rail TS 35 in accordance with EN 60715 • Mounting position any • Shockproof terminal connection according to VBG 4 (PZ1 required), IP rating IP20 • Tightening torque max. 1Nm

Terminal capacity

1 x 0,5 to 2,5mm² with/without multicore cable end • 1 x 4mm² without multicore cable end • 2 x 0,5 to 1,5mm² with/without multicore cable end • 2 x 2,5mm² flexible without multicore cable end

Ambient conditions

Ambient temperature: -25 to 55°C (in accordance with IEC 60068-1); -25 to 40°C (in accordance with UL 508) • Storage temperature: -25 to +70°C • Transport temperature: -25 to +70°C • relative humidity: 15% to 85% (in accordance with IEC 60721-3-3 class 3K3) • Pollution degree: 3 (in accordance with IEC 60664-1) • Vibration resistance: 10 to 55Hz 0,35mm (in accordance with IEC 60068-2-6) • Shock resistance: 15g 11ms (in accordance with IEC 60068-2-27)

Accessories

PowerModules TR3 (12 - 500V AC)



True power monitoring of 1- or 3-phase loads with adjustable switching thresholds, adjustable start-up suppression time, separately adjustable tripping delay, selectable fault latch and temperature monitoring of the motor winding.

- OVER:** Overload monitoring
- OVER+I=0 ON:** Overload monitoring and recognition of disconnected consumers (relay ON or OFF)
- UNDER:** UNDERload monitoring
- UNDER+I=0 ON:** UNDERload monitoring and recognition of disconnected consumers (relay ON or OFF)
- 2MIN:** Minimum monitoring
- 2MIN+I=0 ON:** Minimum monitoring and recognition of disconnected consumers (relay ON or OFF)
- 2MAX:** Maximum monitoring
- 2MAX+I=0 ON:** Maximum monitoring and recognition of disconnected consumers (relay ON or OFF)
- WIN:** Monitoring the window between MIN and MAX
- WIN+I=0 ON:** Monitoring the window between MIN and MAX and recognition of disconnected consumers (relay ON or OFF)
- MIN/MAX:** Minimum- and Maximum monitoring
- MIN/MAX+I=0 ON:** Minimum- and maximum monitoring and recognition of disconnected consumers (relay ON or OFF)

Connected 3~ 400V with power module 24V AC without fault latch
I_N<12A

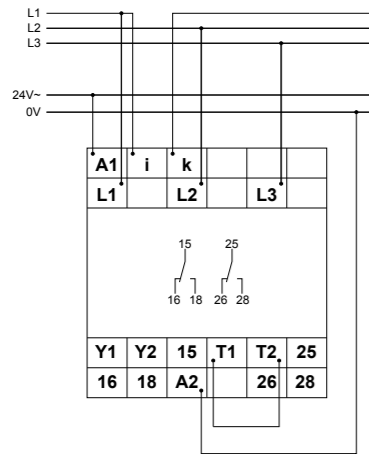

Connected 1~ 230V with power module 230V AC without fault latch but with current transformer. I_N>12A

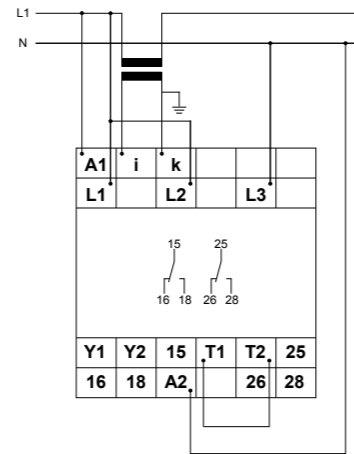

Connected 3~ 400V with power module 400V AC with fault latch
I_N<12A

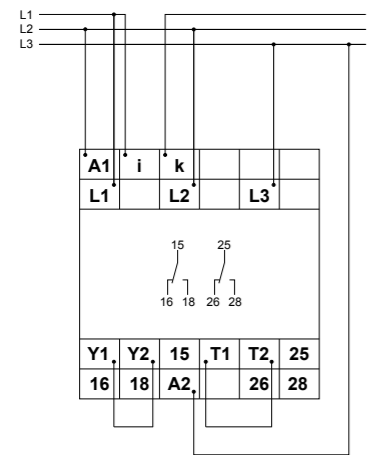

Connected 3~ 400V with power module 400V AC with fault latch and current transformer I_N>12A

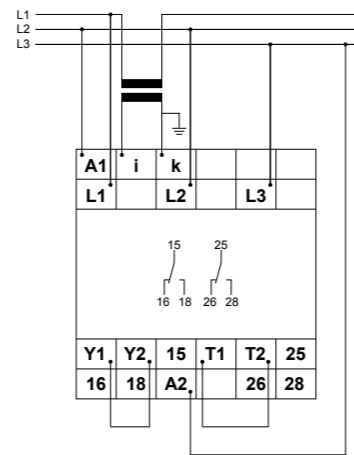

Connected 3~ 400V with power module 400V AC with fault latch and temperature monitoring sensor I_N<12A

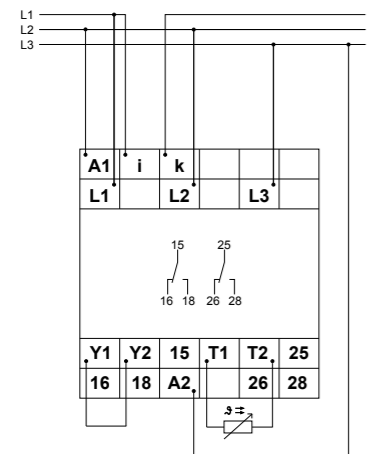

Width 45mm

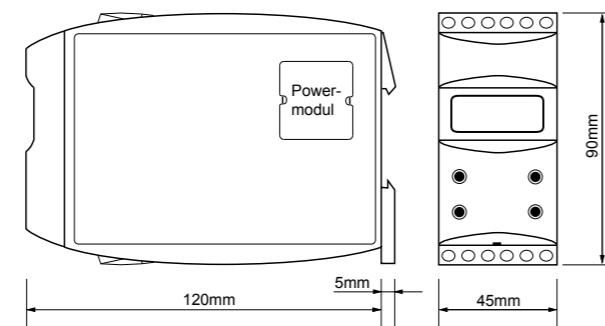

Functions



Loadmonitors Series GAMMA
True power monitoring for 1- or 3-phase loads



- Multifunction
- Temperature monitoring of the motor coil
- Fault latch; Reset button
- Recognition of disconnected load I=0
- Suitable for VFI (10 to 100Hz)
- Supply voltage selectable via power modules
- 2 CO contact
- Width 45mm
- Industrial design

Connections

Type

G4BM480V12ATL20

G4BM480V12AFTL20



Art.No. (PQ1)

2394702

2394705

Art.No. (PQ10)

-

-

EAN13-Code

900866200615

9008662006010

Measured variable

True power consumption 1- or 3-phase Loads
AC Sinus (10 to 400Hz)

True power consumption 1- or 3-phase Loads
AC Sinus (10 to 400Hz)

Measured range P_N

0,75kW • 1,5kW • 3kW • 6kW

0,75kW • 1,5kW • 3kW • 6kW

Measuring voltage

1-Phase loads: 0 to 480V AC
3-Phase loads: 3~ 0 to 480/277V

1-Phase loads: 0 to 480V AC
3-Phase loads: 3~ 0 to 480/277V

Mesuring ranges Current

Measuring rangese 0,75 and 1,5kW: 0 to 6A
Measuring rangese 3 and 6kW: 0 to 12A

Measuring rangese 0,75 and 1,5kW: 0 to 6A
Measuring rangese 3 and 6kW: 0 to 12A

Controls

Start • P1 • Delay • Range • Function •
I< • P2 • Reset

Start • P1 • Delay • Range • Function •
I< • P2 • Reset

Indicators (LEDs)

U/t • Failure P1 • Rel1 • I=0 • Failure P2 • Temp • Rel2

U/t • Failure P1 • Rel1 • I=0 • Failure P2 • Temp • Rel2

Functions

2MAX
2MIN
WIN
MIN/MAX
I=0 with optionally selectable relay setting

2MAX
2MIN
WIN
MIN/MAX
I=0 with optionally selectable relay setting

Trigger level P

P1: 10% to 120% from P_N
P2: 5% to 110% from P_N

P1: 10% to 120% from P_N
P2: 5% to 110% from P_N

Hysteresis

fixed, ca. 3% from P_N

fixed, ca. 3% from P_N

Tripping delay

0,1s to 50s

0s to 10s

Start-up suppression time

1s to 100s

1s to 10s

Fault latch

Wire link Y1-Y2

Wire link Y1-Y2

Supply

PowerModule TR3 (12 - 500V AC)
Terminals A1-A2

PowerModule TR3 (12 - 500V AC)
Terminals A1-A2

Output

2 CO contact
250V 5AAC

2 CO contact
250V 5AAC

Width

45mm

45mm

Certificates

CE • GOST

CE • GOST

Mechanical design

Self-extinguishing plastic housing, IP rating IP40 • Mounted on DIN-Rail TS 35 in accordance with EN 60715 • Mounting position any • Shockproof terminal connection according to VBG 4 (PZ1 required), IP rating IP20 • Tightening torque max. 1Nm

Terminal capacity

1 x 0,5 to 2,5mm² with/without multicore cable end • 1 x 4mm² without multicore cable end • 2 x 0,5 to 1,5mm² with/without multicore cable end • 2 x 2,5mm² flexible without multicore cable end

Ambient conditions

Ambient temperature: -25 to 55°C (in accordance with IEC 60068-1); -25 to 40°C (in accordance with UL 508) • Storage temperature: -25 to +70°C • Transport temperature: -25 to +70°C • relative humidity: 15% to 85% (in accordance with IEC 60721-3-3 class 3K3) • Pollution degree: 3 (in accordance with IEC 60664-1) • Vibration resistance: 10 to 55Hz 0,35mm (in accordance with IEC 60068-2-6) • Shock resistance: 15g 11ms (in accordance with IEC 60068-2-27)

Accessories

PowerModules TR3 (12 - 500V AC) • sealable intervention protection shield FA-G2

2MIN
2MAX
WIN
MIN/MAX

Underload monitoring for two independent thresholds
Underload monitoring for two independent thresholds
Monitoring of the threshold level between min and max areas
Underload and overload monitoring for two independent thresholds

I< Detection of shorted loads with selectable relay setting

Connected 3~ 400V with power module 400V AC with fault latch
 $I_N < 12A$

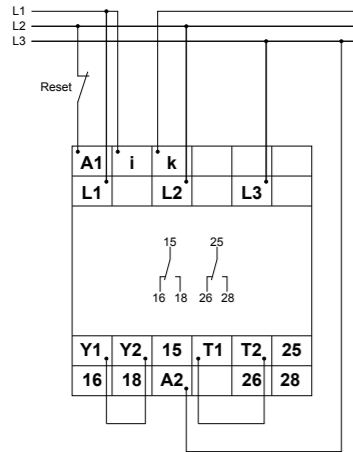

Connected 3~ 400V with power module 400V AC with fault latch and temperature monitoring sensor $I_N > 12A$

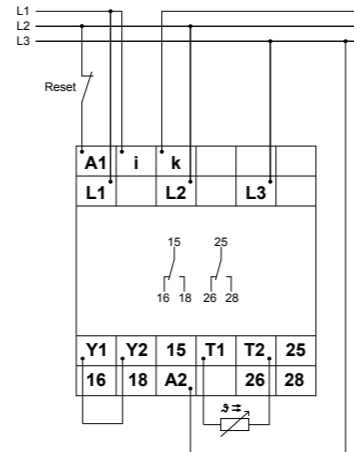

Connected 3~ 400V with power module 400V AC with fault latch and current transformer $I_N < 12A$

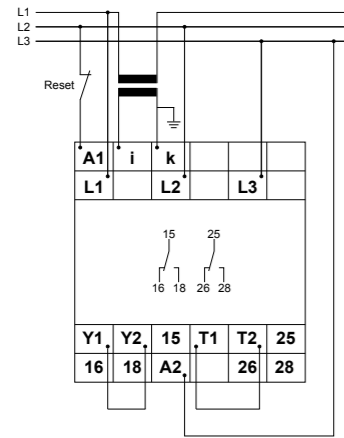

Connected 3~ 400V with power module 24V AC without fault latch and current transformer $I_N > 12A$

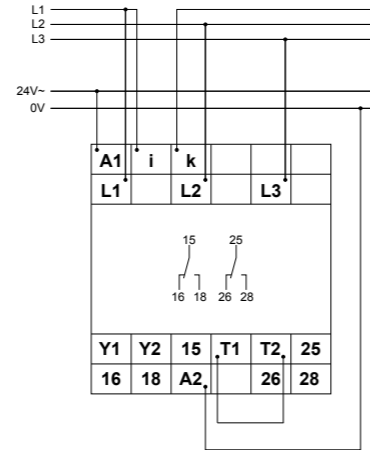

Width 45mm

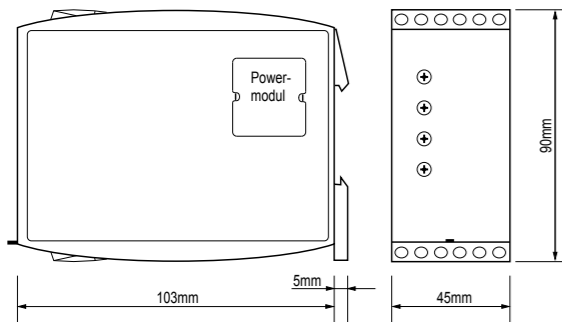

Functions



- Multifunction
- Fault latch
- Recognition of disconnected consumers
- Suitable for VFI (10 to 100Hz)
- Supply voltage selectable via PowerModules
- 1 CO contact; 2 CO contacts
- Width 22,5mm or 45mm
- Industrial design

Connections

types

G2BM480V12AFL10

G2BM400V12AL10

G2BM400V12AFL10



Art.No. (PQ1)

2390707

2390700

2390702

Art.No. (PQ10)

-

-

-

EAN13-Code

9008662006119

900866200291

900866200292

Measured variable

True power consumption 1- or 3-phase loads AC Sinus (10 to 400Hz)

True power consumption of 1- or 3-phase loads AC Sinus (10 to 400Hz)

True power consumption of 1- or 3-phase loads AC Sinus (10 to 400Hz)

Measuring ranges P_N

0,75kW • 1,5kW • 3kW • 6kW

0,5kW • 1kW • 2kW • 4kW

0,5kW • 1kW • 2kW • 4kW

Measuring voltage

1-phase loads: 0 to 480V AC
3-phase loads: 3~ 0 to 480/277V

1-phase loads: 0 to 415VAC
3-phase loads: 3~ 0 to 415/240V

1-phase loads: 0 to 415VAC
3-phase loads: 3~ 0 to 415/240V

Measuring range Current

Measuring ranges 0,75 and 1,5kW: 0 to 6A
Measuring ranges 3 and 6kW: 0 to 12A

Measuring ranges 0,5 and 1kW: 0 to 6A
Measuring ranges 2 and 4kW: 0 to 12A

Measuring ranges 0,5 and 1kW: 0 to 6A
Measuring ranges 2 and 4kW: 0 to 12A

Controls

Start • Power • Delay • Range • Function

Start • Power • Delay • Range • Function

Start • Power • Delay • Range • Function

Indicators (LEDs)

U/t • Failure • I=0 • R

U/t • Failure • I=0 • R

U/t • Failure • I=0 • R

Functions

OVER + I=0
OVER + I=0
UNDER
UNDER + I=0

OVER
OVER + I=0
UNDER
UNDER + I=0

OVER + I=0
OVER + I=0
UNDER
UNDER + I=0

Trigger level P

5% to 120% from P_N

5% to 120% of P_N

5% to 120% of P_N

Hysteresis

fixed, approx. 3% from P_N

fixed, approx. 3% of P_N

fixed, approx. 3% of P_N

Tripping delay

0,1s to 2s

0,1s to 50s

0,1s to 2s

Start-up suppression time

0,1s to 2s

1s to 100s

0,1s to 2s

Fault latch

wire link Y1-Y2

wire link Y1-Y2

wire link Y1-Y2

Supply

PowerModule TR2 or SNT2 terminals A1-A2

PowerModule TR2 or SNT2 terminals A1-A2

PowerModule TR2 or SNT2 terminals A1-A2

Output

1 CO contact
250V 5A AC

1 CO contact
250V 5A AC

1 CO contact
250V 5A AC

Width

22,5mm

22,5mm

22,5mm

Certificates

CE • GOST

CE • GOST

CE • GOST

Mechanical design

Self-extinguishing plastic housing, IP rating IP40 • Mounted on DIN-Rail TS 35 in accordance with EN 60715 • Mounting position any • Shockproof terminal connection according to VBG 4 (PZ1 required), IP rating IP20 • Tightening torque max. 1Nm

Terminal capacity

1 x 0,5 to 2,5mm² with/without multicore cable end • 1 x 4mm² without multicore cable end • 2 x 0,5 to 1,5mm² with/without multicore cable end • 2 x 2,5mm² flexible without multicore cable end

Ambient conditions

Ambient temperature: -25 to 55°C (in accordance with IEC 60068-1); -25 to 40°C (in accordance with UL 508) • Storage temperature: -25 to +70°C • Transport temperature: -25 to +70°C • relative humidity: 15% to 85% (in accordance with IEC 60721-3-3 class 3K3) • Pollution degree: 3 (in accordance with IEC 60664-1) • Vibration resistance: 10 to 55Hz 0,35mm (in accordance with IEC 60068-2-6) • Shock resistance: 15g 11ms (in accordance with IEC 60068-2-27)

Accessories

PowerModules TR2 (12 - 440V AC) and DC power supply SNT2 24VDC • sealable intervention protection shield FA-G2

OVER Overload monitoring
 UNDER Underload monitoring
 OVER+I=0 Overload monitoring with recognition of disconnected consumers
 UNDER+I=0 Underload monitoring with recognition of disconnected consumers
 OVER+I=0 Overload monitoring with recognition of disconnected consumers (Rel.ON if I=0)

Connected 3~ 400V mains with PowerModule 24V AC without fault latch. $I_N < 12A$

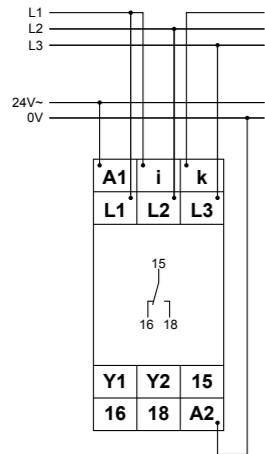

Connected 1~ 230V mains with PowerModule 230V AC without fault latch. $I_N < 12A$

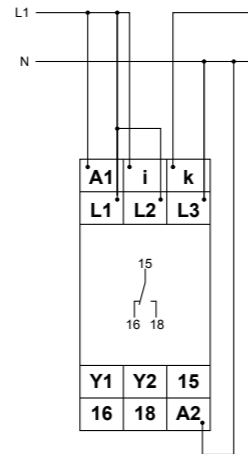

Connected 3~ 400V mains with PowerModule 400V AC and fault latch. $I_N < 12A$

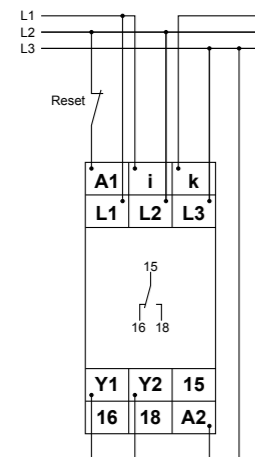

Connected 1~ 230V mains with PowerModule 230V AC without fault latch. $I_N > 12A$

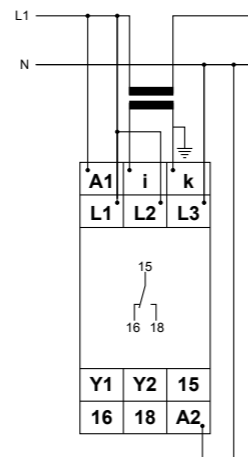

Width 22,5mm

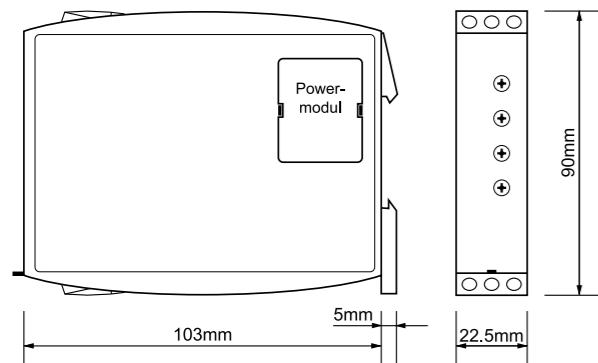

Functions



Loadmonitors Series GAMMA

Measuring transducer

- True power monitoring of 1- or 3-phase loads
- Analogue output 4...20mA
- Suitable for VFI (10 to 100Hz)
- Zoom voltage 24V to 240V DC and 48V to 240V AC
- Width 22,5mm
- Industrial design

Connections

Type

G2BA480V12A 4...20mA



Art.No. (PQ1)

2390705

Art.No. (PQ10)

-

EAN13-Code

9008662006119

Measured variable

True power consumption 1- or 3-phase loads
 AC Sinus (10 to 400Hz)

Measured ranges

0,75kW • 1,5kW • 3kW • 6kW

Measuring voltage

1-Phase loads: 0 to 480V AC
 3-Phase loads: 3~ 0 to 480/277V

Rated current

Measuring rangese 0,5kW and 1,5kW: 0 to 6A
 Measuring rangese 3kW and 6kW: 0 to 12A

Controls

Zero • Zero Fine • Span • Range

Indicators (LEDs)

U • 8 x Analogue Output

Functions

Signal converter for true power

Output

4 to 20mA (Working resistance max. 500Ω)

Isolation

3kV DC

Setting time

< 300 ms

Supply

24 - 240V DC / 48 - 240V AC
 Terminals A1-A2

Width

22,5mm

Certificates

CE • GOST

Mechanical design

Self-extinguishing plastic housing, IP rating IP40 • Mounted on DIN-Rail TS 35 in accordance with EN 60715 • Mounting position any • Shockproof terminal connection according to VBG 4 (PZ1 required), IP rating IP20 • Tightening torque max. 1Nm

Terminal capacity

1 x 0,5 to 2,5mm² with/without multicore cable end • 1 x 4mm² without multicore cable end • 2 x 0,5 to 1,5mm² with/without multicore cable end • 2 x 2,5mm² flexible without multicore cable end

Ambient conditions

Ambient temperature: -25 to 55°C (in accordance with IEC 60068-1); -25 to 40°C (in accordance with UL 508) • Storage temperature: -25 to +70°C • Transport temperature: -25 to +70°C • relative humidity: 15% to 85% (in accordance with IEC 60721-3-3 class 3K3) • Pollution degree: 3 (in accordance with IEC 60664-1) • Vibration resistance: 10 to 55Hz 0,35mm (in accordance with IEC 60068-2-6) • Shock resistance: 15g 11ms (in accordance with IEC 60068-2-27)

Accessories

Sealable intervention protection shield FA-G2

Dimensions

Zero setting of zero point (0%, 25%, 50%, 75% of nominal value)
 Zero Fine fine setting of zero point (0% ... 25% of nominal value)
 Span span (100%, 75%, 50%, 25% of nominal value)
 Range measuring range reversible between 0.6kW, 1.2kW, 2.4kW, 4.8kW

G2BA480V12A 4...20mA in 3-phase mains

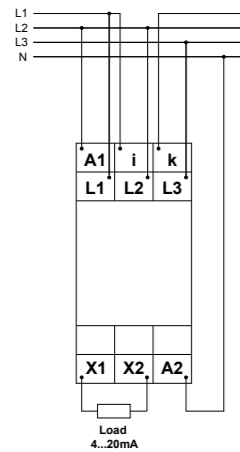

G2BA480V12A 4...20mA in 3-phase mains with current transformer

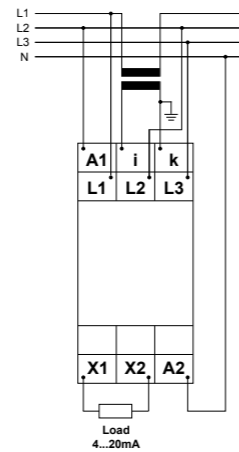

Width 22,5mm

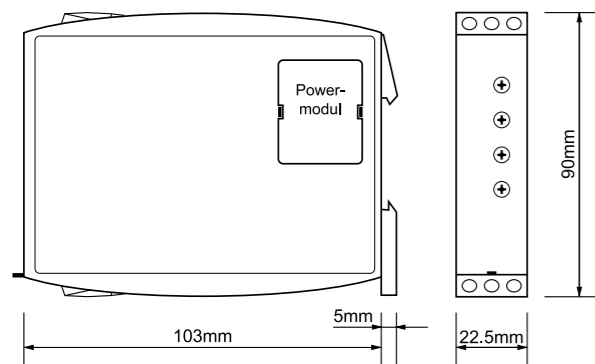

Functions



Loadmonitors Serie GAMMA

Measuring transducer



- Effective current measurement
- Analogue output 4...20mA
- Suitable for VFI (10 to 100Hz)
- Zoom voltage 24V to 240V DC and 48V to 240V AC
- Width 22,5mm
- Industrial design

Connections

types

G2IA15A 4...20mA



Art.No. (PQ1)

2390710

Art.No. (PQ10)

-

EAN13-Code

9008662006645

Measured variable

Current DC/AC (10 bis 400 Hz)

Measured range

5A • 10A • 15A

Controls

Zero • Zero Time • Span • Range

Indicators (LEDs)

U • 8 x Analogue output

Functions

Signal converter for effective current

Output

4 bis 20mA (Working resistance max. 500Ω)

Isolation

3kV DC

Setting time

< 500 ms

Supply

24-240V DC / 48-240V AC
terminals A1-A2

Width

22,5mm

Certificates

CE • GOST

Mechanical design

Self-extinguishing plastic housing, IP rating IP40 • Mounted on DIN-Rail TS 35 in accordance with EN 60715 • Mounting position any • Shockproof terminal connection according to VBG 4 (PZ1 required), IP rating IP20 • Tightening torque max. 1Nm

Terminal capacity

1 x 0,5 to 2,5mm² with/without multicore cable end • 1 x 4mm² without multicore cable end • 2 x 0,5 to 1,5mm² with/without multicore cable end • 2 x 2,5mm² flexible without multicore cable end

Ambient conditions

Ambient temperature: -25 to 55°C (in accordance with IEC 60068-1); -25 to 40°C (in accordance with UL 508) • Storage temperature: -25 to +70°C • Transport temperature: -25 to +70°C • relative humidity: 15% to 85% (in accordance with IEC 60721-3-3 class 3K3) • Pollution degree: 3 (in accordance with IEC 60664-1) • Vibration resistance: 10 to 55Hz 0,35mm (in accordance with IEC 60068-2-6) • Shock resistance: 15g 11ms (in accordance with IEC 60068-2-27)

Accessories

Sealable intervention protection shield FA-G2

Dimensions

Zero setting of zero point (0%, 25%, 50%, 75% of nominal value)
 Zero Fine fine setting of zero point (0% ... 25% of nominal value)
 Span span (100%, 75%, 50%, 25% of nominal value)
 Range measuring range reversible between 5A, 10A, 15A

G2IA15A 4...20mA in 3-phase mains

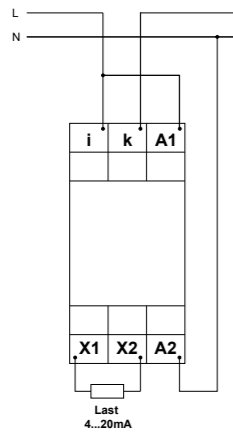

G2IA15A 4...20mA in 3-phase mains with current transformer

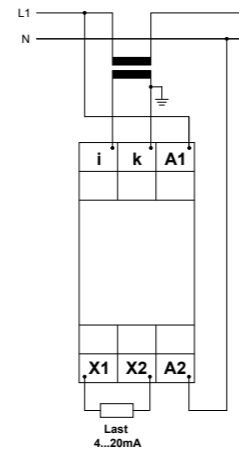

Width 22,5mm

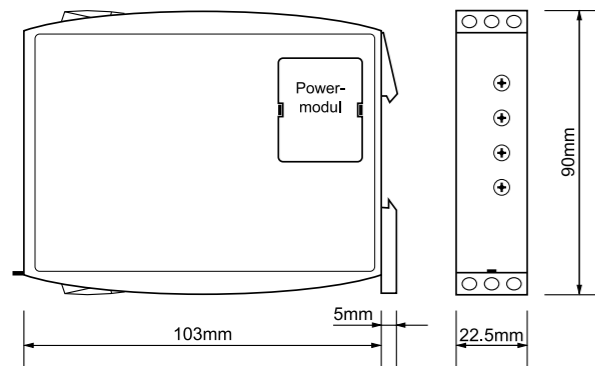

Functions



Loadmonitors Series GAMMA

Power factor monitoring (cosφ) in 1- or 3-phase mains



- Multifunction (G2CM)
- Underload monitoring (G2CU)
- Fault latch
- Recognition of disconnected consumers I=0
- Suitable for VFI (10 to 100Hz)
- Supply voltage selectable via PowerModules
- 2 CO contacts (G2CM); 1 CO contact (G2CU)
- Width 22,5mm
- Industrial design

Connections

types

G2CM400V10AL20

G2CM400V2AL20

G2CU400V10AL10



Art.No. (PQ1)

2390602

2390606

2390600

Art.No. (PQ10)

-

-

-

EAN13-Code

900866200289

900866200290

900866200288

Measured variable

Power factor (cosφ) of 1- or 3-phase loads AC Sinus (10 to 100Hz)

Power factor (cosφ) of 1- or 3-phase loads AC Sinus (10 to 100Hz)

Power factor (cosφ) of 1- or 3-phase loads AC Sinus (10 to 100Hz)

Measured range

0,1 to 1

0,1 to 1

0,1 to 1

Measuring voltage

1-phase loads: 40 to 240VAC
3-phase loads: 3~ 40/23 to 415/240V

1-phase loads: 40 to 240VAC
3-phase loads: 3~ 40/23 to 415/240V

1-phase loads: 40 to 240VAC
3-phase loads: 3~ 40/23 to 415/240V

Rated current

0,5 to 10A

0,05 to 2A

0,5 to 10A

Controls

Start • max • min • Delay • Function

Start • max • min • Delay • Function

Start • min • Delay • Function

Indicators (LEDs)

U/t • min • max • I=0 • R

U/t • min • max • I=0 • R

U/t • min • I=0 • R

Functions

OVER
OVER+LATCH
UNDER
UNDER+LATCH
WIN
WIN+LATCH

OVER
OVER+LATCH
UNDER
UNDER+LATCH
WIN
WIN+LATCH

UNDER
UNDER+LATCH

Switching threshold max.

cosφ = 0,2 to 1,0

cosφ = 0,2 to 1,0

-

Switching threshold min.

cosφ = 0,1 to 0,99

cosφ = 0,1 to 0,99

cosφ = 0,1 to 1,0

Hysteresis

-

-

fixed, approx. 3°
(according to 3% bei cosφ=0,8)

Tripping delay

0,1s to 40s

0,1s to 40s

0,1s to 40s

Start-up suppression time

1s to 100s

1s to 100s

1s to 100s

Fault latch

selectable

selectable

selectable

Supply

PowerModule TR2 or SNT2 terminals A1-A2

PowerModule TR2 or SNT2 terminals A1-A2

PowerModule TR2 or SNT2 terminals A1-A2

Output

2 CO contacts; 250V, 5A AC

2 CO contacts; 250V, 5A AC

1 CO contact; 250V, 5A AC

Width

22,5mm

22,5mm

22,5mm

Certificates

CE • cULus • GOST

CE • cULus • GOST

CE • cULus • GOST

Mechanical design

Self-extinguishing plastic housing, IP rating IP40 • Mounted on DIN-Rail TS 35 in accordance with EN 60715 • Mounting position any • Shockproof terminal connection according to VBG 4 (PZ1 required), IP rating IP20 • Tightening torque max. 1Nm

Terminal capacity

1 x 0,5 to 2,5mm² with/without multicore cable end • 1 x 4mm² without multicore cable end • 2 x 0,5 to 1,5mm² with/without multicore cable end • 2 x 2,5mm² flexible without multicore cable end

Ambient conditions

Ambient temperature: -25 to 55°C (in accordance with IEC 60068-1); -25 to 40°C (in accordance with UL 508) • Storage temperature: -25 to +70°C • Transport temperature: -25 to +70°C • relative humidity: 15% to 85% (in accordance with IEC 60721-3-3 class 3K3) • Pollution degree: 3 (in accordance with IEC 60664-1) • Vibration resistance: 10 to 55Hz 0,35mm (in accordance with IEC 60068-2-6) • Shock resistance: 15g 11ms (in accordance with IEC 60068-2-27)

Accessories

PowerModules TR2 (12 - 440V AC) and DC power supply SNT2 24 VDC • sealable intervention protection shield FA-G2

| | |
|-------------|--|
| OVER | Overload monitoring |
| OVER+LATCH | Overload monitoring with fault latch |
| UNDER | Underload monitoring |
| UNDER+LATCH | Underload monitoring with fault latch |
| WIN | Monitoring the window between Min and Max |
| WIN+LATCH | Monitoring the window between Min and Max with fault latch |

Functions

Connected to 3~ 400V mains with PowerModule 24V AC without fault latch. $I_N < 10A$

Connected to 1~ 230V mains with PowerModule 230V AC without fault latch. $I_N < 10A$

Connected to 3~ 400V mains with PowerModule 400V AC and fault latch. $I_N < 10A$

Connected to 3~ 400V mains with PowerModule 400V AC and fault latch. $I_N > 10A$

Connections

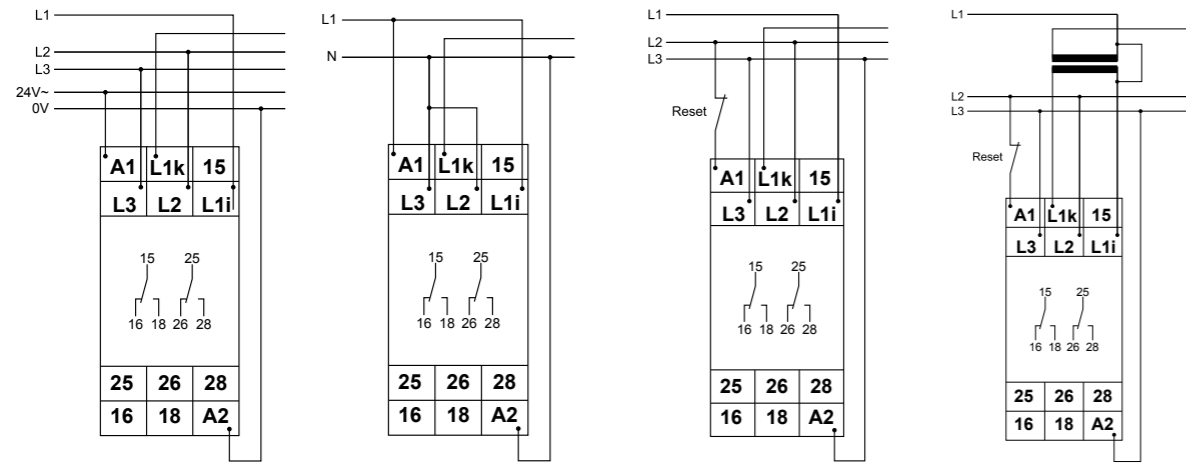

Width 22,5mm

Dimensions

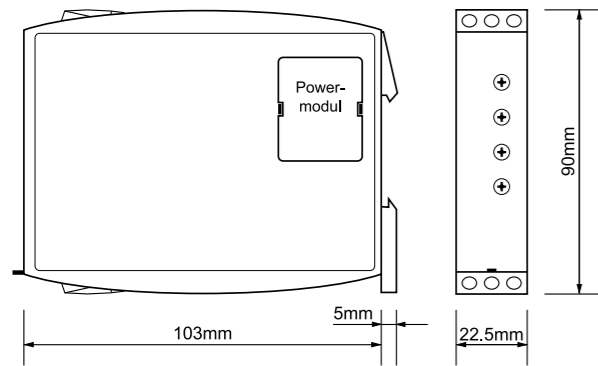

TIME RELAYS



OVERVIEW

TELE offers the widest range of products with the following performance features:

- Functionality ranging from simple delayed activation right up to multifunctional timing relays with a remote potentiometer connection and potential-free control contact
- Internal or external power supply (e.g. 24V DC)
- Various forms of housing for control engineering, industrial systems and machine building as well as building installations
- Variants available for DIN rails, switchboard or front installation, 11-pole plug-in base or industrial relays

The robust design with generous terminal space throughout ensures very good usability and installability.



| | | Page |
|-------------------------------------|--|--|
| Selection matrix Time relays | Quick and explicit to the right product. | 105 |
| Function overview | Explanations of important terms - A, Bi, Bp, ... | 108 |
| Time Relays | - Series Industry: GAMMA - Series Industry compact: DELTA - Series plugable: KAPPA, PLUS - Series Installation: ENYA - Front installation: FRONT, RONDO - TimeModule: COMBI | 111 121 131 135 147 149 |
| Star-Delta-Relays | - Series Industry: GAMMA - Series Industry compact: DELTA - Series plugable: KAPPA - Series Installation: ENYA | 119 129 131 141 |
| Light Controller | - Series Installation: ENYA | 143 |
| Emergency light tester | - Series Installation: ENYA | 145 |

A
OFF Delay without Auxiliary Voltage

Bi
Flasher pulse first

Bp
Flasher pause first

R
OFF delay

S
Star-Delta start-up

T
Automatic timer without switch-off warning

E
ON delay

ER
ON and OFF delay with control contact

Es
ON delay with control contact

TW
Automatic timer with switch-off warning

Wa
Single shot trailing edge with control contact

Wi
Impulse switch with OFF delay

EWs
ON delay and single shot leading edge with control contact

EWu
ON delay and single shot leading edge voltage controlled

li
Asymmetric flasher pulse first

Ws
Single shot leading edge with control contact

WsWa
Single shot leading and trailing edge with control contact

Wt
Pulse detection

Ip
Asymmetric flasher pause first

P
Impulse switch mode without time function

PN
Impulse switch mode power fail latch

Wu
Single shot leading edge voltage controlled

nWa
Maintained single shot trailing edge

nWuWa
Maintained single shot leading and trailing edge



Time Relays Series GAMMA

Multifunction Timer



- Multifunction
- 16 time ranges (G2ZMF11); 7 time ranges (G2ZM20)
- Time setting by 2 or 3 controls for the selection of range and fine tuning
- Remote potentiometer optional (G2ZMF11)
- Supply voltage 12-240V AC/DC (G2ZM20)
- Supply voltage selectable via PowerModules, DC power supply or by zoom voltage
- 2 CO contacts (G2ZMF11: individual switching by functions with instantaneous contact)
- Width 22,5mm
- Industrial design

types

G2ZMF11 24-240V AC/DC

G2ZMF11

G2ZM20 12-240V AC/DC

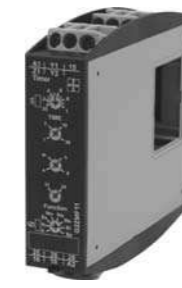

Art.No. (PQ1)

120103

120100

120401

Art.No. (PQ10)

-

-

-

EAN13-Code

900866200026

900866200025

900866200031

Controls

Time • 11/20 • Function

Time • 11/20 • Function

Time • Function

Indicators (LEDs)

U/t • R

U/t • R

U/t • R

Functions

E11 • E20
R11 • R20
Es11 • Es20
Wu11 • Wu20
Ws11 • Ws20
Wa11 • Wa20
Bi11 • Bi20
Bp11 • Bp20

E11 • E20
R11 • R20
Es11 • Es20
Wu11 • Wu20
Ws11 • Ws20
Wa11 • Wa20
Bi11 • Bi20
Bp11 • Bp20

E
R
Es
Wu
Ws
Wa
Bi
Bp

Inst. contact

selectable

selectable

-

2-time function

-

-

-

Time ranges

1 • 3 • 10 • 30s
1 • 3 • 10 • 30min
1 • 3 • 10 • 30h
1 • 3 • 10 • 30d

1 • 3 • 10 • 30s
1 • 3 • 10 • 30min
1 • 3 • 10 • 30h
1 • 3 • 10 • 30d

1 • 10s
1 • 10min
1 • 10 • 100h

Adjustment range

5% to 100%

5% to 100%

5% to 100%

Control input

terminals Y1-Y2
galvanic separated

terminals Y1-Y2
galvanic separated

terminals A1-B1
loadable

Remote potentiometer

1 (optional); Z1-Y2

1 (optional); Z1-Y2

-

Supply

24 to 240V AC/DC
terminals A1-A2

PowerModulee TR2 or SNT2
terminals A1-A2

12 to 240V AC/DC
terminals A1-A2

Output

2 CO contacts
250V, 5AAC

2 CO contacts
250V, 5AAC

2 CO contacts
250V, 5AAC

Width

22,5mm

22,5mm

22,5mm

Certificates

CE • cULus • GOST

CE • cULus • GOST

CE • cULus • GOST

Mechanical design

Self-extinguishing plastic housing, IP rating IP40 • Mounted on DIN-Rail TS 35 in accordance with EN 60715 • Mounting position any • Shockproof terminal connection according to VBG 4 (PZ1 required) • IP rating IP20 • Tightening torque max. 1Nm

Terminal capacity

1 x 0,5 to 2,5mm² with/without multicore cable end • 1 x 4mm² without multicore cable end • 2 x 0,5 to 1,5mm² with/without multicore cable end • 2 x 2,5mm² flexible without multicore cable end

Ambient conditions

Ambient temperature: -25 to 55°C (in accordance with IEC 60068-1); -25 to 40°C (in accordance with UL 508) • Storage temperature: -25 to +70°C • Transport temperature: -25 to +70°C • relative humidity: 15% to 85% (in accordance with IEC 60721-3-3 class 3K3) • Pollution degree: 3 (in accordance with IEC 60664-1) • Vibration resistance: 10 to 55Hz 0,35mm (in accordance with IEC 60068-2-6) • Shock resistance: 15g 11ms (in accordance with IEC 60068-2-27)

Accessories

PowerModules TR2 (12 - 440V AC) • DC power supply SNT2 24V DC • Remote potentiometer R2 • sealable intervention protection shield FA-G2

G2ZMF11 and G2ZMF11 24-240V

1 delayed contact (cl. 15-16-18) and 1 inst. contact (cl. 25-26-28)

- E11 ON delay
- R11 OFF delay with control contact
- Es11 ON delay with control contact
- Wu11 Single shot leading edge voltage controlled
- Ws11 Single shot leading edge with control contact
- Wa11 Single shot trailing edge with control contact
- Bi11 Flasher pulse first
- Bp11 Flasher pause first

2 delayed contacts

- E20 ON delay
- R20 OFF delay with control contact
- Es20 ON delay with control contact
- Wu20 Single shot leading edge voltage controlled
- Ws20 Single shot leading edge with control contact
- Wa20 Single shot trailing edge with control contact
- Bi20 Flasher pulse first
- Bp20 Flasher pause first

G2ZM20

- E ON delay
- R OFF delay with control input
- Es ON delay with control input
- Wu Single shot leading edge voltage controlled
- Ws Single shot leading edge with control input
- Wa Single shot trailing edge with control input
- Bi Flasher pulse first
- Bp Flasher pause first

G2ZMF11; G2ZMF11 24-240V

G2ZM20

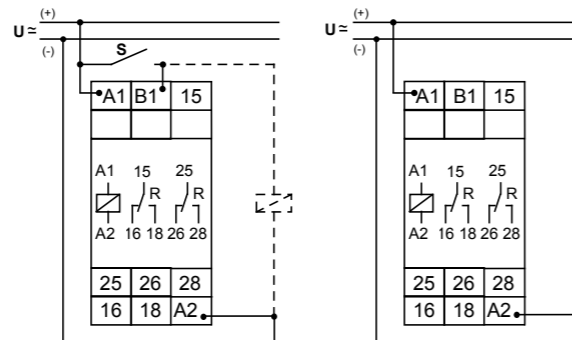
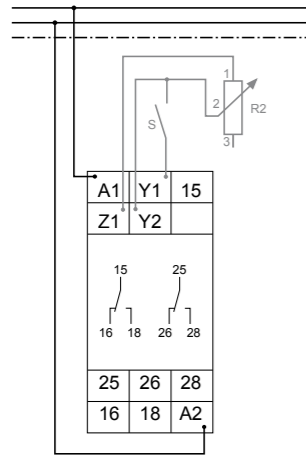

Width 22,5mm

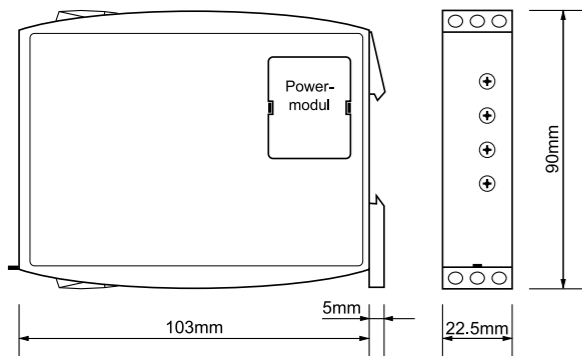

Functions



Time Relays Serie GAMMA

Multifunction Timer

- Multifunction
- Off delay without auxiliary voltage
- Four time ranges
- Supply voltage can be selected via power module or zoom voltage
- 2 CO contacts
- Width 22,5mm
- Industrial design



Connections

types

G2ZA20 10min 24-240V AC/DC

G2ZA20 10min



Art.No. (PQ1)

120600

120601

Art.No. (PQ10)

-

-

EAN13-Code

Controls

Time • Function

Time • Function

Indicators (LEDs)

U

U

Functions

E • A • nWa • nWu • nWuWa

E • A • nWa • nWu • nWuWa

Inst. contact

-

-

2-time function

-

-

Time ranges

1 • 10s
1 • 10min

1 • 10s
1 • 10min

Adjustment range

5% to 100%

5% to 100%

Control input

-

-

Remote potentiometer

-

-

Supply

24 to 240V AC/DC
terminals A1-A2

PowerModulee TR2 or SNT2
terminals A1-A2

Output

2 CO contacts
250V, 5AAC

2 CO contacts
250V, 5AAC

Width

22,5mm

22,5mm

Certificates

CE • GOST

CE • GOST

Mechanical design

Self-extinguishing plastic housing, IP rating IP40 • Mounted on DIN-Rail TS 35 in accordance with EN 60715 • Mounting position any • Shockproof terminal connection according to VBG 4 (PZ1 required) • IP rating IP20 • Tightening torque max. 1Nm

Terminal capacity

1 x 0,5 to 2,5mm² with/without multicore cable end • 1 x 4mm² without multicore cable end • 2 x 0,5 to 1,5mm² with/without multicore cable end • 2 x 2,5mm² flexible without multicore cable end

Ambient conditions

Ambient temperature: -25 to 55°C (in accordance with IEC 60068-1); -25 to 40°C (in accordance with UL 508) • Storage temperature: -25 to +70°C • Transport temperature: -25 to +70°C • relative humidity: 15% to 85% (in accordance with IEC 60721-3-3 class 3K3) • Pollution degree: 3 (in accordance with IEC 60664-1) • Vibration resistance: 10 to 55Hz 0,35mm (in accordance with IEC 60068-2-6) • Shock resistance: 15g 11ms (in accordance with IEC 60068-2-27)

Accessories

PowerModules TR2 (12-440V AC) • DC power supply SNT2 24V DC • sealable intervention protection shield FA-G2

Dimensions

E On delay
 A Off delay without auxiliary voltage
 nWa Maintained single shot trailing edge
 nWu Maintained single shot leading edge
 nWuWa Maintained single shot leading and single shot trailing edge

G2ZA20

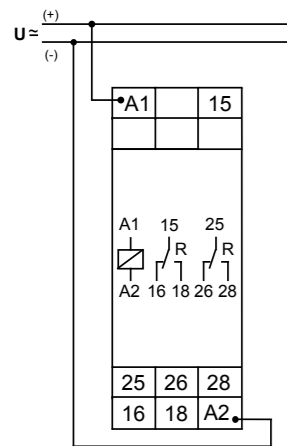

Width 22,5mm

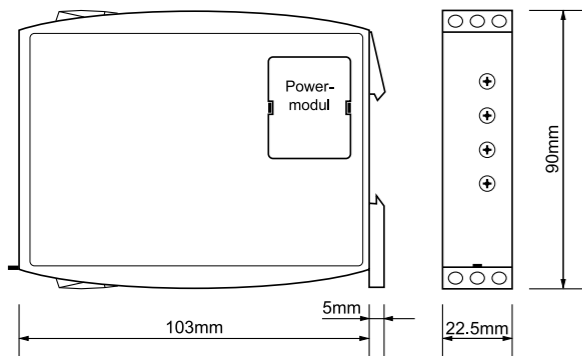

Functions



- Multifunction
- 10 time ranges (G2ZIF20); 7 time ranges (G2ZI20)
- Remote potentiometer optional (G2ZIF20)
- Supply voltage 12-240V AC/DC (G2ZI20)
- Supply voltage selectable via PowerModules or by zoom voltage
- 2 CO contacts
- Width 22,5mm
- Industrial design

Time Relays Series GAMMA

2-Time Multifunction Timer



Connections

types

G2ZIF20 24-240V AC/DC

G2ZIF20

G2ZI20 12-240V AC/DC



Art.No. (PQ1)

120201

120200

120501

Art.No. (PQ10)

-

-

-

EAN13-Code

900866200028

900866200027

900866200032

Controls

Time1 • Time2 • Function

Time1 • Time2 • Function

Time1 • Time2 • Function

Indicators (LEDs)

U/t₁ • t₂ • R

U/t₁ • t₂ • R

U/t • R

Functions

Ip • li • ER • EWu • EWs • WsWa • Wt

Ip • li • ER • EWu • EWs • WsWa • Wt

Ip • li • ER • EWu • EWs • WsWa

Inst. contact

-

-

-

2-time function

yes

yes

yes

Time ranges

1 • 3 • 10 • 30s
 1 • 3 • 10 • 30min
 1 • 10h

1 • 3 • 10 • 30s
 1 • 3 • 10 • 30min
 1 • 10h

1 • 10s
 1 • 10min
 1 • 10 • 100h

Adjustment range

5% to 100%

5% to 100%

5% to 100%

Control input

terminals Y1-Y2
 galvanic separated

terminals Y1-Y2
 galvanic separated

terminals A1-B1
 loadable

Remote potentiometer

Time1: terminals Z1-Y2
 Time2: terminals Z2-Y2

Time1: terminals Z1-Y2
 Time2: terminals Z2-Y2

-

Supply

24 to 240V AC/DC
 terminals A1-A2

PowerModule TR2 or SNT2
 terminals A1-A2

12 to 240V AC/DC
 terminals A1-A2

Output

2 CO contacts
 250V, 5A AC

2 CO contacts
 250V, 5A AC

2 CO contacts
 250V, 5A AC

Width

22,5mm

22,5mm

22,5mm

Certificates

CE • cULus • GOST

CE • cULus • GOST

CE • cULus • GOST

Mechanical design

Self-extinguishing plastic housing, IP rating IP40 • Mounted on DIN-Rail TS 35 in accordance with EN 60715 • Mounting position any • Shockproof terminal connection according to VBG 4 (PZ1 required) • IP rating IP20 • Tightening torque max. 1Nm

Terminal capacity

1 x 0,5 to 2,5mm² with/without multicore cable end • 1 x 4mm² without multicore cable end • 2 x 0,5 to 1,5mm² with/without multicore cable end • 2 x 2,5mm² flexible without multicore cable end

Ambient conditions

Ambient temperature: -25 to 55°C (in accordance with IEC 60068-1); -25 to 40°C (in accordance with UL 508) • Storage temperature: -25 to +70°C • Transport temperature: -25 to +70°C • relative humidity: 15% to 85% (in accordance with IEC 60721-3-3 class 3K3) • Pollution degree: 3 (in accordance with IEC 60664-1) • Vibration resistance: 10 to 55Hz 0,35mm (in accordance with IEC 60068-2-6) • Shock resistance: 15g 11ms (in accordance with IEC 60068-2-27)

Accessories

PowerModules TR2 (12 - 440V AC) • DC power supply SNT2 24V DC • Remote potentiometer RONDO R2 • sealable intervention protection shield FA-G2

Dimensions

Art.No. (PQ1)

Art.No. (PQ10)

EAN13-Code

Controls

Indicators (LEDs)

Functions

Inst. contact

2-time function

Time ranges

Adjustment range

Control input

Remote potentiometer

Supply

Output

Width

Certificates

Mechanical design

Terminal capacity

Ambient conditions

Accessories

G2ZIF20
 Ip Asymmetric flasher pause first
 li Asymmetric flasher pulse first
 ER ON delay and OFF delay with control contact
 EWu ON delay single shot leading edge voltage controlled
 EWs ON delay single shot leading edge with control contact
 WsWa Single shot leading and single shot trailing edge with control contact
 Wt Pulse sequence monitoring

G2ZI20
 Ip Asymmetric flasher pause first
 li Asymmetric flasher pulse first
 ER ON delay and OFF delay with control contact
 EWu ON delay single shot leading edge voltage controlled
 EWs ON delay single shot leading edge with control contact
 WsWa Single shot leading and single shot trailing edge with control contact

G2ZIF20; G2ZIF20 24-240V

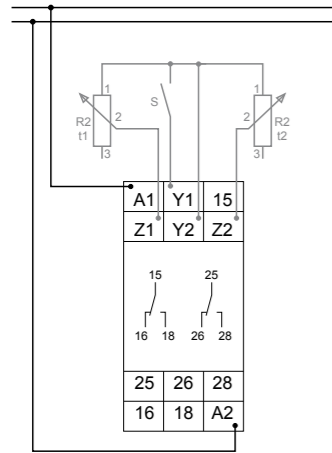

G2ZI20 12-240VAC/DC

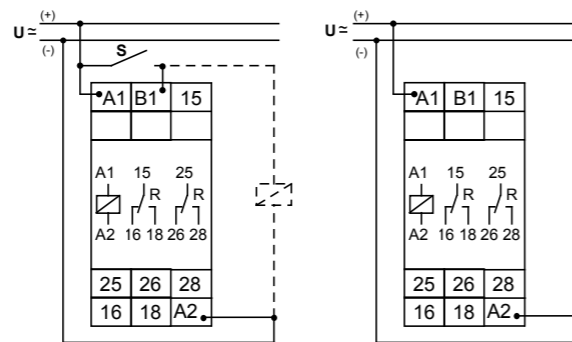

Width 22,5mm

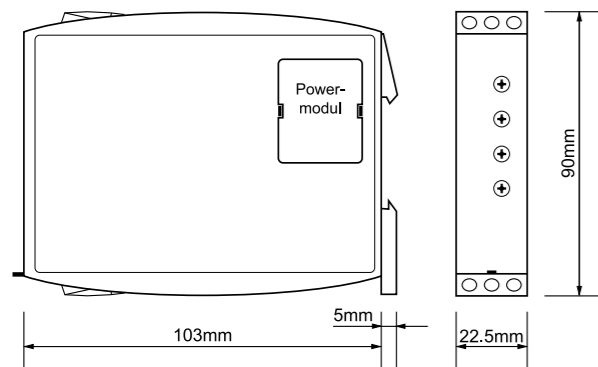

Functions



Time Relays Series GAMMA

Singlefunction Timer

- ON delay
- 16 time ranges
- Supply voltage 400V AC
- 1 CO contact
- Width 22,5mm
- Industrial design



Connections

types

G2ZE10 400V AC



Art.No. (PQ1)

120104

Art.No. (PQ10)

-

EAN13-Code

9008662005440

Controls

Time

Indicators (LEDs)

U/t • R

Functions

E

Inst. contact

-

2-time function

-

Time ranges

1 • 3 • 10 • 30s
 1 • 3 • 10 • 30min
 1 • 3 • 10 • 30h
 1 • 3 • 10 • 30d

Adjustment range

5% to 100%

Control input

-

Remote potentiometer

-

Supply

400V AC
 terminals A1-A2

Output

1 CO contact
 250V, 5AAC

Width

22,5mm

Certificates

CE • cULus • GOST

Mechanical design

Self-extinguishing plastic housing, IP rating IP40 • Mounted on DIN-Rail TS 35 in accordance with EN 60715 • Mounting position any • Shockproof terminal connection according to VBG 4 (PZ1 required), IP rating IP20 • Tightening torque max. 1Nm

Terminal capacity

1 x 0,5 to 2,5mm² with/without multicore cable end • 1 x 4mm² without multicore cable end • 2 x 0,5 to 1,5mm² with/without multicore cable end • 2 x 2,5mm² flexible without multicore cable end

Ambient conditions

Ambient temperature: -25 to 55°C (in accordance with IEC 60068-1); -25 to 40°C (in accordance with UL 508) • Storage temperature: -25 to +70°C • Transport temperature: -25 to +70°C • relative humidity: 15% to 85% (in accordance with IEC 60721-3-3 class 3K3) • Pollution degree: 3 (in accordance with IEC 60664-1) • Vibration resistance: 10 to 55Hz 0,35mm (in accordance with IEC 60068-2-6) • Shock resistance: 15g 11ms (in accordance with IEC 60068-2-27)

Accessories

Sealable intervention protection shield FA-G2

Dimensions

G2ZE10 400VAC

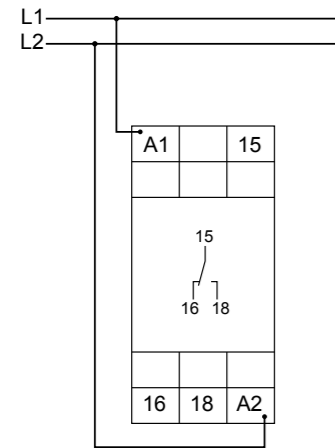

Width 22,5mm

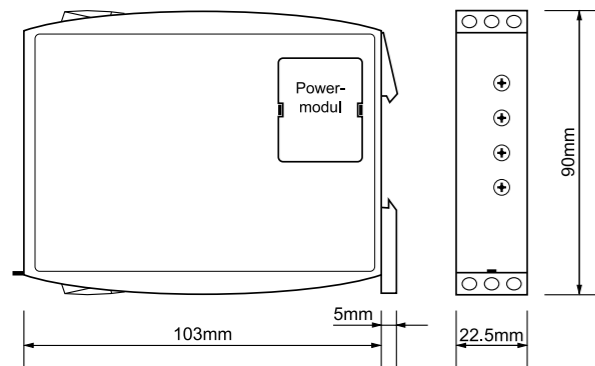

Functions



Time Relays Series GAMMA

Star-Delta Timer

- Star-Delta start-up
- 4 time ranges (star-time)
- Transit time selectable
- Supply voltage via PowerModules or DC power supply by zoom voltage 24 to 240V AC/DC
- 2 CO contacts
- Width 22,5mm
- Industrial design



Connections

types

G2ZS20 24-240V AC/DC

G2ZS20



| | 120301 | 120300 |
|--------------------|--|---|
| Art.No. (PQ1) | 120301 | 120300 |
| Art.No. (PQ10) | - | - |
| EAN13-Code | 900866200030 | 900866200029 |
| Controls | Time Y • Time Y → Δ | Time Y • Time Y → Δ |
| Indicators (LEDs) | U/Y • R | U/Y • R |
| Functions | S | S |
| Inst. contact | - | - |
| 2-time function | - | - |
| Time ranges | Time Y: 10s • 30s • 1min • 3min Time Y → Δ: 40ms • 60ms • 80ms • 100ms | Time Y: 10s • 30s • 1min • 3min Time Y → Δ: 40ms • 60ms • 80ms • 100ms |
| Adjustment range | 5% to 100% (TimeY) | 5% to 100% (TimeY) |
| Control input | - | - |
| Supply | 24 to 240V AC/DC terminals A1-A2 | PowerModule TR2 or SNT2 terminals A1-A2 |
| Output | 2 CO contacts 250V, 5A AC | 2 CO contacts 250V, 5A AC |
| Width | 22,5mm | 22,5mm |
| Certificates | CE • cULus • GOST | CE • cULus • GOST |
| Mechanical design | Self-extinguishing plastic housing, IP rating IP40 • Mounted on DIN-Rail TS 35 in accordance with EN 60715 • Mounting position any • Shockproof terminal connection according to VBG 4 (PZ1 required) • IP rating IP20 • Tightening torque max. 1Nm | |
| Terminal capacity | 1 x 0,5 to 2,5mm ² with/without multicore cable end • 1 x 4mm ² without multicore cable end • 2 x 0,5 to 1,5mm ² with/without multicore cable end • 2 x 2,5mm ² flexible without multicore cable end | |
| Ambient conditions | Ambient temperature: -25 to 55°C (in accordance with IEC 60068-1); -25 to 40°C (in accordance with UL 508) • Storage temperature: -25 to +70°C • Transport temperature: -25 to +70°C • relative humidity: 15% to 85% (in accordance with IEC 60721-3-3 class 3K3) • Pollution degree: 3 (in accordance with IEC 60664-1) • Vibration resistance: 10 to 55Hz 0,35mm (in accordance with IEC 60068-2-6) • Shock resistance: 15g 11ms (in accordance with IEC 60068-2-27) | |
| Accessories | PowerModules TR2 (12 - 440V AC) • DC power supply SNT2 24VDC • sealable intervention protection shield FA-G2 | |

Dimensions

G2ZS20; G2ZS20 24-240V

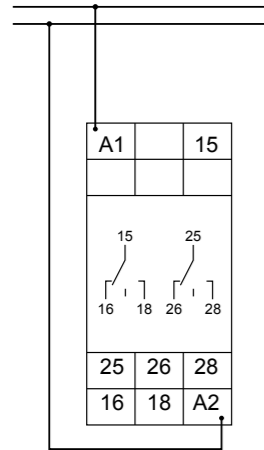

Width 22,5mm

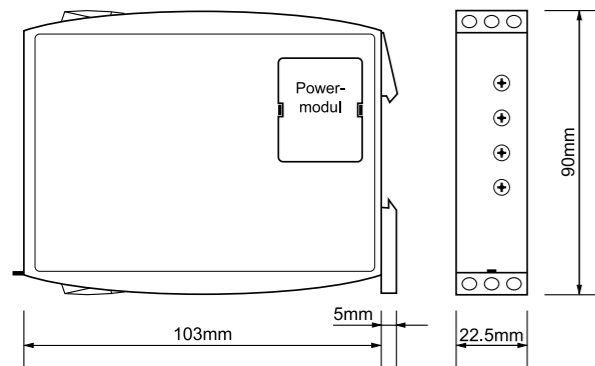

Functions



Time Relays Series DELTA

Multifunction Timer



- Multifunction
- 8 time ranges
- Supply voltage through zoom voltage 12 to 240V AC/DC (D6M); dualvoltage (D6DM; D6DQ)
- 1 CO contact
- Width 22,5mm
- Industrial design

Connections

types

D6M 12-240V AC/DC

D6DM
24V AC/DC 110-240V ACD6DQ
24V AC/DC 110-240V AC

Art.No. (PQ1)

234002

234000

234010

Art.No. (PQ10)

-

-

-

EAN13-Code

900866200130

900866200127

900866200134

Controls

Time • Function

Time • Function

Time • Function

Indicators (LEDs)

U/t • R

U/t • R

U/t • R

Functions

E • R • Ws • Wa • Es • Wu • Bp • Wt

E • R • Ws • Wa • Es • Wu • Bp • Wt

E • R • Wu • Bp

Inst. contact

-

-

-

2-time function

-

-

-

Time ranges

1 • 10s
1 • 10min
1 • 10h
1 • 10d1 • 10s
1 • 10min
1 • 10h
1 • 10d1 • 10s
1 • 10min
1 • 10h
1 • 10d

Adjustment range

5% to 100%

5% to 100%

5% to 100%

Control input

terminals A1-B1
loadableterminals A1-B1
loadableterminals A1-B1
loadable

Remote potentiometer

-

-

-

Supply

12 to 240V AC/DC
terminals A1-A2switchable
24V AC/DC or
110 to 240V AC
terminals A1-A2switchable
24V AC/DC or
110 to 240V AC
terminals A1-A2

Output

1 CO contact
250V, 5AAC1 CO contact
250V, 5AAC1 CO contact
250V, 5AAC

Width

22,5mm

22,5mm

22,5mm

Certificates

CE • cULus • GOST

CE • cULus • GOST

CE • cULus • GOST

Mechanical design

Self-extinguishing plastic housing, IP rating IP40 • Mounted on DIN-Rail TS 35 in accordance with EN 60715 • Mounting position any • Shockproof terminal connection according to VBG 4 (PZ1 required), IP rating IP20 • Tightening torque max. 1Nm

Terminal capacity

1 x 0,5 to 2,5mm² with/without multicore cable end • 1 x 4mm² without multicore cable end • 2 x 0,5 to 1,5mm² with/without multicore cable end • 2 x 2,5mm² flexible without multicore cable end

Ambient conditions

Ambient temperature: -25 to 55°C (in accordance with IEC 60068-1); -25 to 40°C (in accordance with UL 508) • Storage temperature: -25 to +70°C • Transport temperature: -25 to +70°C • relative humidity: 15% to 85% (in accordance with IEC 60721-3-3 class 3K3) • Pollution degree: 3 (in accordance with IEC 60664-1)

Accessories

-

- E ON delay
- R OFF delay with control contact
- Ws Single shot leading edge with control contact
- Wa Single shot trailing edge with control contact
- Es ON delay with control contact
- Wu Single shot leading edge voltage controlled
- Bp Flasher pause first
- Wt Pulse detection

D6M; D6DM; D6DQ

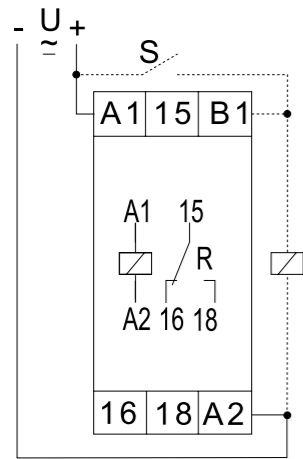

Width 22,5mm

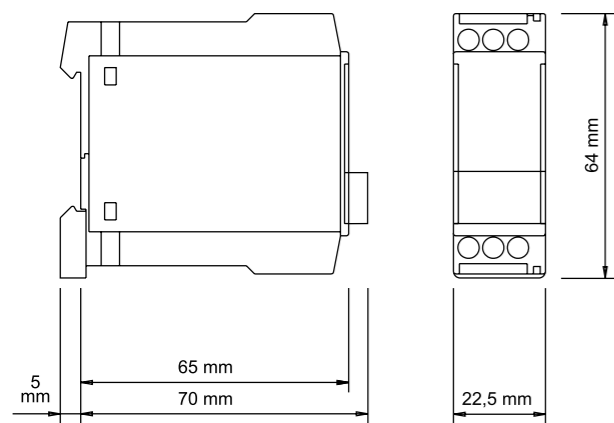

Functions



Time Relays Series DELTA

Singlefunction Timer



- ON delay (D6DE)
- ON delay two wire connection (D6DET)
- 8 time ranges (D6DE)
- 4 time ranges (D6DET)
- Dualvoltage
- 1 CO contact (D6DE)
- 1 Thyristor (D6DET)
- Width 22,5mm
- Industrial design

Connections

types D6DE 24V AC/DC 110V AC D6DE 24V AC/DC 230V AC D6DET 4MIN 12-240V AC/DC D6DET 40MIN 12-240V AC/DC



| | D6DE 24V AC/DC 110V AC | D6DE 24V AC/DC 230V AC | D6DET 4MIN 12-240V AC/DC | D6DET 40MIN 12-240V AC/DC |
|----------------------|--|--|--|--|
| Art.No. (PQ1) | 234051 | 234050 | 234090 | 234091 |
| Art.No. (PQ10) | - | - | - | - |
| EAN13-Code | 900866200137 | 900866200136 | 900866200145 | 900866200146 |
| Controls | Time | Time | Time | Time |
| Indicators (LEDs) | U/t • R | U/t • R | U/t • R | - |
| Functions | E | E | E | E |
| Inst. contact | - | - | - | - |
| 2-time function | - | - | - | - |
| Time ranges | 1 • 10s 1 • 10min 1 • 10h 1 • 10d | 1 • 10s 1 • 10min 1 • 10h 1 • 10d | 1 • 4s • 30s 4min | 10 • 40s 5 • 40min |
| Adjustment range | 5% to 100% | 5% to 100% | 5% to 100% | 5% to 100% |
| Control input | - | - | - | - |
| Remote potentiometer | - | - | - | - |
| Supply | switchable 24V AC/DC or 110V AC terminals A1-A2 | switchable 24V AC/DC or 230V AC terminals A1-A2 | selectable through wire link 12 to 60V AC/DC or 60 to 240V AC terminals A1-A2 | selectable through wire link 12 to 60V AC/DC or 60 to 240V AC terminals A1-A2 |
| Output | 1 CO contact 250V, 5AAC | 1 CO contact 250V, 5AAC | 1 Thyristor 250V, 10 to 500mA AC | 1 Thyristor 250V, 10 to 500mA AC |
| Width | 22,5mm | 22,5mm | 22,5mm | 22,5mm |
| Certificates | CE • cULus • GOST | CE • cULus • GOST | CE • GOST | CE • GOST |
| Mechanical design | Self-extinguishing plastic housing, IP rating IP40 • Mounted on DIN-Rail TS 35 in accordance with EN 60715 • Mounting position any • Shockproof terminal connection according to VBG 4 (PZ1 required), IP rating IP20 • Tightening torque max. 1Nm | | | |
| Terminal capacity | 1 x 0,5 to 2,5mm ² with/without multicore cable end • 1 x 4mm ² without multicore cable end • 2 x 0,5 to 1,5mm ² with/without multicore cable end • 2 x 2,5mm ² flexible without multicore cable end | | | |
| Ambient conditions | Ambient temperature: -25 to 55°C (in accordance with IEC 60068-1); -25 to 40°C (in accordance with UL 508) • Storage temperature: -25 to +70°C • Transport temperature: -25 to +70°C • relative humidity: 15% to 85% (in accordance with IEC 60721-3-3 class 3K3) • Pollution degree: 3 (in accordance with IEC 60664-1) | | | |
| Accessories | - | | | |

Dimensions

D6DE

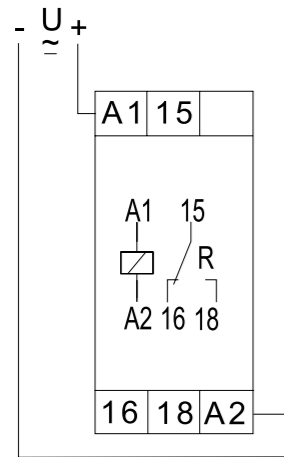

D6DET 12-60V AC/DC

D6DET 60-240V AC/DC

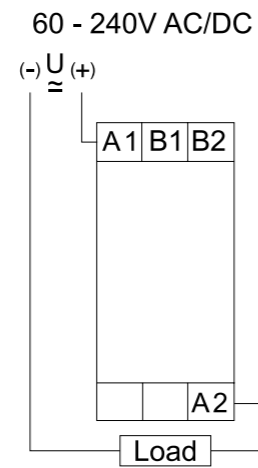
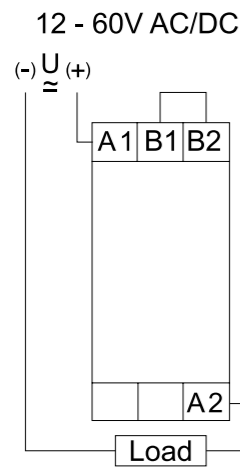

Width 22,5mm

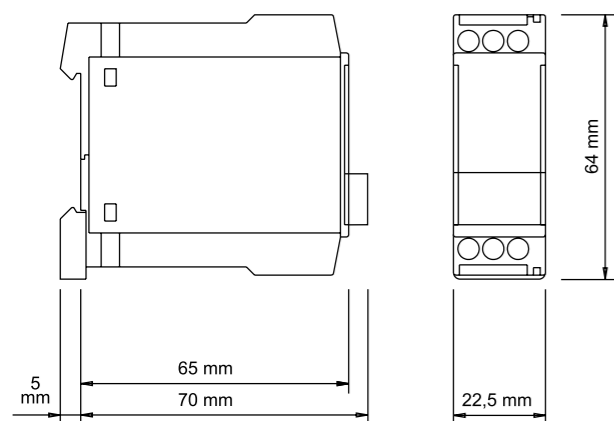

Functions



Time Relays Series DELTA

Singlefunction Timer

- OFF delay with control contact (D6DR)
- OFF delay without auxiliary voltage (D6A)
- 8 time ranges (D6DR)
- 4 time ranges (D6A)
- Dualvoltage (D6DR); zoom voltage (D6A)
- 1 CO contact
- Width 22,5mm
- Industrial design

Connections

types

D6DR 24V AC/DC 110V AC

D6DR 24V AC/DC 230V AC

D6A
3MIN 24-240V AC/DC

D6A
10MIN 24-240V AC/DC



Art.No. (PQ1)

234061

234060

234007

234008

Art.No. (PQ10)

-

-

-

-

EAN13-Code

900866200140

900866200139

9008662005754

9008662005976

Controls

Time

Time

Time

Time

Indicators (LEDs)

U/t • R

U/t • R

U

U

Functions

R

R

A

A

Inst. contact

-

-

-

-

2-time function

-

-

-

-

Time ranges

1 • 10s
1 • 10min
1 • 10h
1 • 10d

1 • 10s
1 • 10min
1 • 10h
1 • 10d

1 • 10s
1 • 3min

1 • 10s
1 • 10min

Adjustment range

5% to 100%

5% to 100%

10% to 100%

10% to 100%

Control input

terminals A1-B1
loadable

terminals A1-B1
loadable

-

-

Remote potentiometer

-

-

-

-

Supply

switchable
24V AC/DC or
110V AC
terminals A1-A2

switchable
24V AC/DC or
230V AC
terminals A1-A2

24-240V AC/DC
terminals A1-A2

24-240V AC/DC
terminals A1-A2

Output

1 CO contact
250V, 5AAC

1 CO contact
250V, 5AAC

1 CO contact
250V, 5AAC

1 CO contact
250V, 5AAC

Width

22,5mm

22,5mm

22,5mm

22,5mm

Certificates

CE • cULus • GOST

CE • cULus • GOST

CE • GOST

CE • GOST

Mechanical design

Self-extinguishing plastic housing, IP rating IP40 • Mounted on DIN-Rail TS 35 in accordance with EN 60715 • Mounting position any • Shockproof terminal connection according to VBG 4 (PZ1 required), IP rating IP20 • Tightening torque max. 1Nm

Terminal capacity

1 x 0,5 to 2,5mm² with/without multicore cable end • 1 x 4mm² without multicore cable end • 2 x 0,5 to 1,5mm² with/without multicore cable end • 2 x 2,5mm² flexible without multicore cable end

Ambient conditions

Ambient temperature: -25 to 55°C (in accordance with IEC 60068-1); -25 to 40°C (in accordance with UL 508) • Storage temperature: -25 to +70°C • Transport temperature: -25 to +70°C • relative humidity: 15% to 85% (in accordance with IEC 60721-3-3 class 3K3) • Pollution degree: 3 (in accordance with IEC 60664-1)

Accessories

-

Dimensions

- R OFF delay with control contact
- A OFF delay without auxiliary voltage

D6DR

D6A

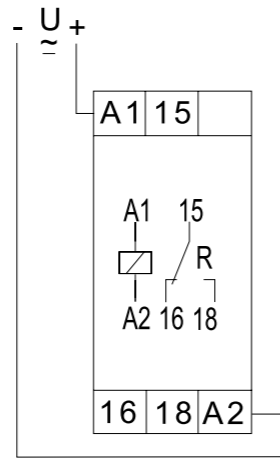
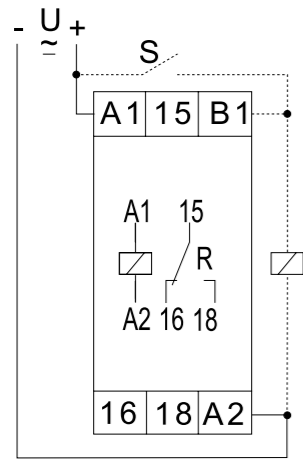

Width 22,5mm

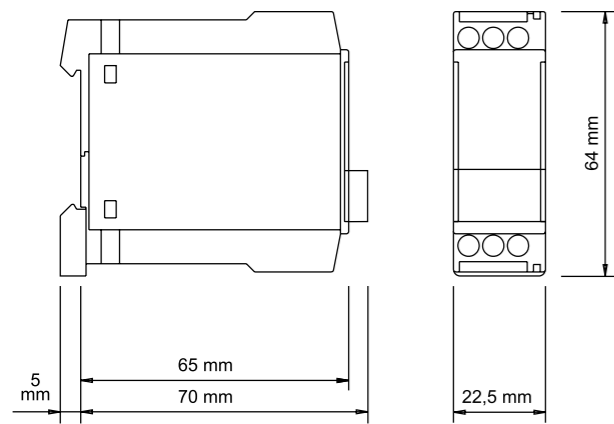

Functions



Time Relays Series DELTA

2-Time Multifunction Timer

- Asymmetric flasher
- 2-time function
- 8 time ranges
- Dualvoltage
- 1 CO contact
- Width 22,5mm
- Industrial design



Connections

types

D6DI 24V AC/DC 110-240V AC



Dimensions

| | |
|----------------------|--|
| Art.No. (PQ1) | 234011 |
| Art.No. (PQ10) | - |
| EAN13-Code | 900866200135 |
| Controls | Time1 • Time2 |
| Indicators (LEDs) | U/t • R |
| Functions | Ip • Ii (with wire link A1-B1) |
| Inst. contact | - |
| 2-time function | yes |
| Time ranges | 1 • 10s 1 • 10min 1 • 10h 1 • 10d |
| Adjustment range | 5% to 100% |
| Control input | - |
| Remote potentiometer | - |
| Supply | switchable 24V AC/DC or 110 to 240V AC terminals A1-A2 |
| Output | 1 CO contact 250V, 5AAC |
| Width | 22,5mm |
| Certificates | CE • cULus • GOST |
| Mechanical design | Self-extinguishing plastic housing, IP rating IP40 • Mounted on DIN-Rail TS 35 in accordance with EN 60715 • Mounting position any • Shockproof terminal connection according to VBG 4 (PZ1 required), IP rating IP20 • Tightening torque max. 1Nm |
| Terminal capacity | 1 x 0,5 to 2,5mm ² with/without multicore cable end • 1 x 4mm ² without multicore cable end • 2 x 0,5 to 1,5mm ² with/without multicore cable end • 2 x 2,5mm ² flexible without multicore cable end |
| Ambient conditions | Ambient temperature: -25 to 55°C (in accordance with IEC 60068-1); -25 to 40°C (in accordance with UL 508) • Storage temperature: -25 to +70°C • Transport temperature: -25 to +70°C • relative humidity: 15% to 85% (in accordance with IEC 60721-3-3 class 3K3) • Pollution degree: 3 (in accordance with IEC 60664-1) |
| Accessories | - |

- lp Asymmetric flasher pause first
- li Asymmetric flasher pulse first (with wire link A1-B1)

D6DI

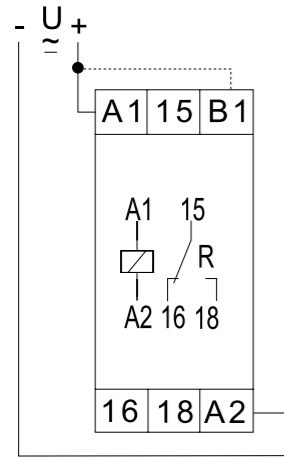

Width 22,5mm

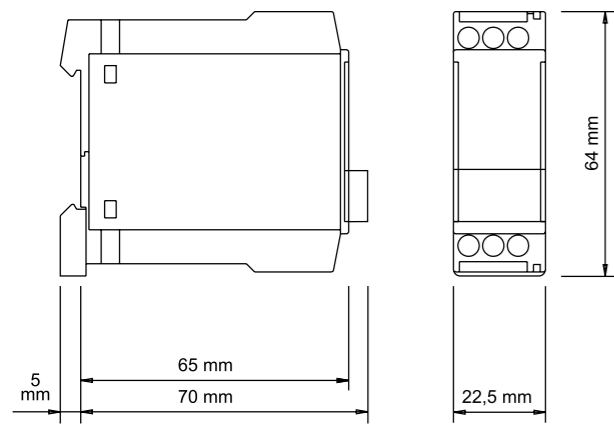

Functions



Time Relays Series DELTA

Star-Delta Timer

- Star-Delta start-up
- 4 time ranges
- Dualvoltage
- 2 NO contacts
- Width 22,5mm
- Industrial design



Connections

types

D6DS 24V AC/DC 110-240V AC



Dimensions

| | |
|--------------------|--|
| Art.No. (PQ1) | 234070 |
| Art.No. (PQ10) | - |
| EAN13-Code | 900866200141 |
| Controls | Time Y • Time Y → Δ |
| Indicators (LEDs) | U • R |
| Functions | S |
| Inst. contact | - |
| 2-time function | - |
| Time ranges | Time Y: 10s • 30s • 1min • 3min Time Y → Δ: 40ms • 60ms • 80ms • 100ms |
| Adjustment range | 5% to 100% (TimeY) |
| Control input | - |
| Supply | switchable 24V AC/DC or 110 to 240V AC terminals A1-A2 |
| Output | 2 NO contacts 250V, 8AAC |
| Width | 22,5mm |
| Certificates | CE • cULus • GOST |
| Mechanical design | Self-extinguishing plastic housing, IP rating IP40 • Mounted on DIN-Rail TS 35 in accordance with EN 60715 • Mounting position any • Shockproof terminal connection according to VBG 4 (PZ1 required), IP rating IP20 • Tightening torque max. 1Nm |
| Terminal capacity | 1 x 0,5 to 2,5mm ² with/without multicore cable end • 1 x 4mm ² without multicore cable end • 2 x 0,5 to 1,5mm ² with/without multicore cable end • 2 x 2,5mm ² flexible without multicore cable end |
| Ambient conditions | Ambient temperature: -25 to 55°C (in accordance with IEC 60068-1); -25 to 40°C (in accordance with UL 508) • Storage temperature: -25 to +70°C • Transport temperature: -25 to +70°C • relative humidity: 15% to 85% (in accordance with IEC 60721-3-3 class 3K3) • Pollution degree: 3 (in accordance with IEC 60664-1) |
| Accessories | - |

D6DS

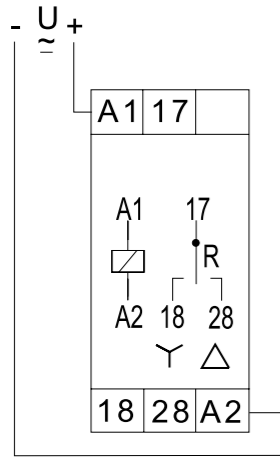

Width 22,5mm

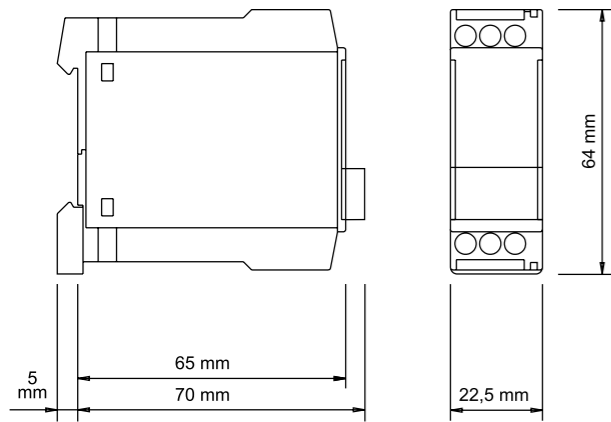

Functions



Time Relays Series KAPPA

Multifunction Timer

- Multifunction (K3ZM, K3ZA20)
- 2-Time Multifunction Timer (K3ZI20)
- Start-Delta start-up (K3ZS20)
- 7 time ranges (K3ZM and K3ZI20)
- 4 time ranges (K3ZS20, K3ZA20)
- Supply voltage through zoom voltage 12 to 240V AC/DC or 24 to 240V AC/DC
- 2 CO contacts
- Width 38mm
- Plug-in mounting



Connections

types

K3ZM20 12-240V AC/DC K3ZM20P 12-240V AC/DC K3ZI20 12-240V AC/DC K3ZS20 12-240V AC/DC K3ZA20 24-240V AC/DC



| | K3ZM20 12-240V AC/DC | K3ZM20P 12-240V AC/DC | K3ZI20 12-240V AC/DC | K3ZS20 12-240V AC/DC | K3ZA20 24-240V AC/DC |
|----------------------|--|--|--|---|------------------------------|
| Art.No. (PQ1) | 135100 | 135200 | 135101 | 135300 | 135400 |
| Art.No. (PQ10) | - | - | - | - | - |
| EAN13-Code | 9008662005914 | 9008662006492 | 9008662005921 | 9008662005938 | 9008662006133 |
| Controls | Time • Function | Time • Function | Time 1 • Time 2 • Function | Time Y • Time Y → Δ | Time • Function |
| Indicators (LEDs) | U/t • R | U/t • R | U/t • R | U/t • R | U |
| Functions | E • R • Es • Wa • Es • Wu • Bp | E • R • Es • Wa • Es • Wu • Bp | Ip • li • ER • EWu • EWs • WsWa • Wt | S | E • A • nWa • nWu • nWuWa |
| Inst. contact | - | - | - | - | - |
| 2-time function | - | - | yes | - | - |
| Time ranges | 1 • 10s 1 • 10min 1 • 10h • 100h | 1 • 10s 1 • 10min 1 • 10h • 100h | 1 • 10s 1 • 10min 1 • 10h • 100h | Time Y: 10s • 30s • 1min • 3min Time Y → Δ: 40ms • 60ms • 80ms • 100ms | 1 • 10s 1 • 3min |
| Adjustment range | 5% to 100% | 5% to 100% | 5% to 100% | 5% to 100% (Time Y) | 5% to 100% |
| Control input | pins S2-S5 loadable | pins S5-S6 Not potential free Potential free control | pins S2-S5 loadable | - | - |
| Remote potentiometer | - | - | - | - | - |
| Supply | 12 to 240V AC/DC pins S2-S10 | 12 to 240V AC/DC pins S2-S10 | 12 to 240V AC/DC pins S2-S10 | 12 to 240V AC/DC pins S2-S10 | 24 to 240V AC/DC pins S2-S10 |
| Output | 2 CO 250V, 8A AC | 2 CO 250V, 8A AC | 2 CO 250V, 8A AC | 2 CO 250V, 8A AC | 2 CO 250V, 8A AC |
| Width | 38mm | 38mm | 38mm | 38mm | 38mm |
| Certificates | CE | CE | CE | CE | CE |
| Mechanical design | Self-extinguishing plastic housing, IP rating IP40 • Mounted on 11-pole screw terminal socket in accordance with IEC 60067-1-18a • Mounting position: any | | | | |
| Ambient conditions | Ambient temperature: -25 to +55°C • Storage temperature: -25 to +70°C • Transport temperature: -25 to +70°C • Relative humidity: 15% to 85% (in accordance with IEC 60721-3-3 class 3K3) • Pollution degree: 2, if built in 3 (in accordance with IEC 60664-1) | | | | |
| Accessories | Relay socket R11X, PF-113BEIM | | | | |

Dimensions

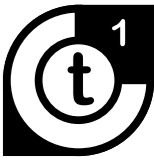

- K3ZM20**
 E ON delay
 R OFF delay with control contact
 Ws Single shot leading edge with control contact
 Wa Single shot trailing edge with control contact
 Es ON delay with control contact
 Wu Single shot leading edge voltage controlled
 Bp Flasher pause first
- K3ZI20**
 Ip Asymmetric flasher pause first
 li Asymmetric flasher pulse first (with wire link A1-B1)
 ER ON delay and OFF delay with control contact
 EWu ON delay single shot leading edge voltage controlled
 EWs ON delay single shot leading edge with control contact
 WsWa Single shot leading and single shot trailing edge with control contact
 Wt Pulse sequence monitoring

- K3ZA20**
 E - ON delay
 A - Off delay without auxiliary voltage
 nWa - Maintained single shot trailing edge
 nWu - Maintained single shot leading edge
 nWuWa - Maintained single shot leading and single shot trailing edge

- K3ZS20**
 S Star-Delta start-up

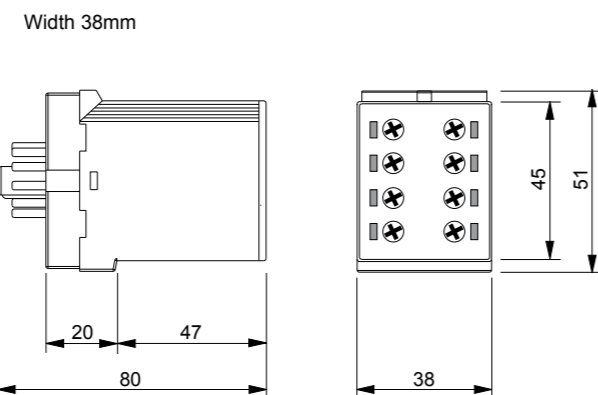
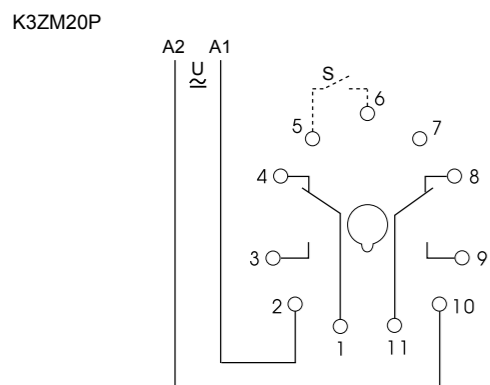
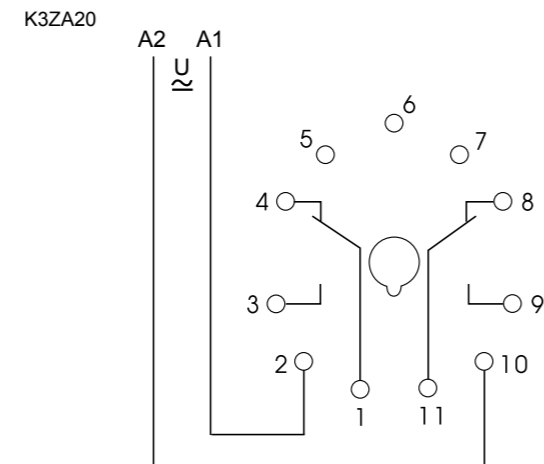
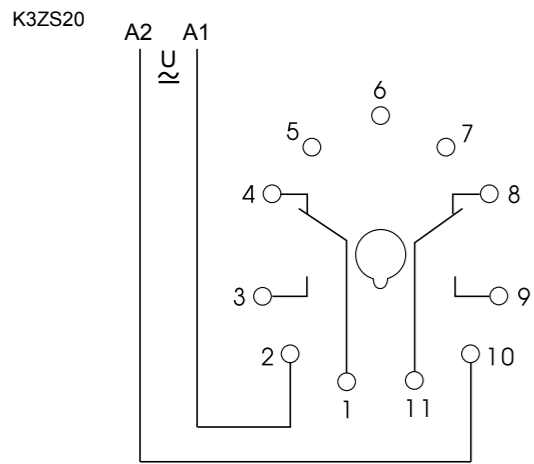
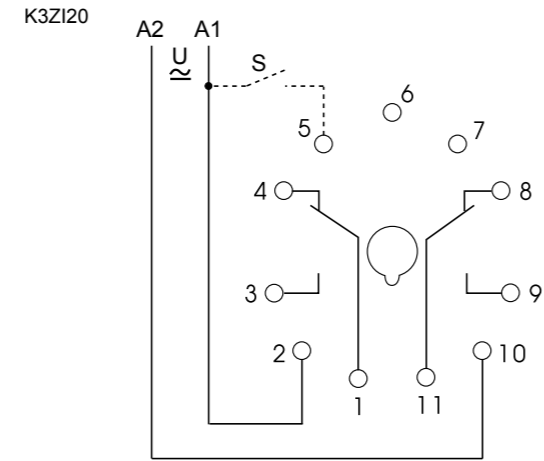
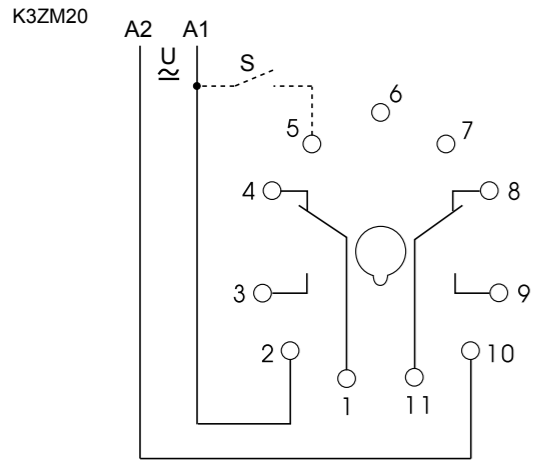

Functions



Time Relays Series PLUS

Multifunction Timer

- Multifunction
- 8 to 16 time ranges
- Remote potentiometer for time setting required (PDM20F; PDI20F)
- 1 CO contact and 1 NO contact (PDM20F)
- 2 CO contacts (PDM11)
- 1 normally closed contact and 1 normally open contact
- Width 38mm
- Cap size 45mm
- Plug-in mounting

Connections

types

PDM20F
24VAC/DC 110-240VAC

PDM11
24VAC/DC 110-240VAC

PDI20F
24VAC/DC 110-240VAC



Art.No. (PQ1)
 Art.No. (PQ10)
 EAN13-Code
 Controls

236003

236100

236011

900866200194

900866200201

900866200198

Time • Function

Time • Function

Time1 • Time2 • Function

Indicators (LEDs)
 Functions

U/t • R

U/t • R

U/t • R

E
 R
 Ws
 Wa
 Es
 Wu
 Bp
 Wt

E11 • E20
 R11 • R20
 Ws11 • Ws20
 Wa11 • Wa20
 Es11 • Es20
 Wu11 • Wu20
 Bp11 • Bp20
 Wt11 • Wt20

Ip
 li
 ER
 EWs
 EWu

Inst. contact
 2-time function
 Time ranges

1 • 10sec
 1 • 10min
 1 • 10h
 1 • 10d

1 • 3 • 10 • 30sec
 1 • 3 • 10 • 30min
 1 • 3 • 10 • 30h
 1 • 3 • 10 • 30d

1 • 10sec
 1 • 10min
 1 • 10h
 1 • 10d

Adjustment range
 Control input

5% to 100%

5% to 100%

5% to 100%

pins S2-S5
 loadable

pins S2-S5
 loadable

pins S2-S5
 loadable

Remote potentiometer

pins S6-S8

-

Time1: pins S3-S6
 Time2: pins S6-S8

Supply

selectable via pins
 24V AC/DC (S2-S7)
 110 to 240V AC (S2-S10)

selectable via pins
 24V AC/DC (S2-S7)
 110 to 240V AC (S2-S10)

selectable via pins
 24V AC/DC (S2-S7)
 110 to 240V AC (S2-S10)

Output

1 CO contact and
 1 NO contact
 250V, 8A AC

2 CO contacts
 250V, 8A AC

1 CO contact and
 1 NO contact
 250V, 8A AC

Width

38mm

38mm

38mm

Certificates

CE • GOST

CE • GOST

CE • GOST

Mechanical design

Self-extinguishing plastic housing, IP rating IP40 • Connection and mounting by 11-pin socket in accordance with IEC 60067-1-18a • Mounting position: any

Ambient conditions

Ambient temperature: -25 to 55°C (in accordance with IEC 60068-1); -25 to 40°C (in accordance with UL 508) • Storage temperature: -25 to +70°C • Transport temperature: -25 to +70°C • relative humidity: 15% to 85% (in accordance with IEC 60721-3-3 class 3K3) • Pollution degree: 3 (in accordance with IEC 60664-1)

Accessories

Relay socket R11X, PF-113BEIM; Remote potentiometer RONDO R2 (1Ω)

Dimensions

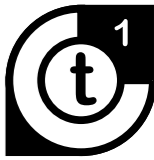

PDM20; PDM20F; PDM10

- E On delay
- R OFF delay with control contact
- Ws Single shot leading edge with control contact
- Wa Single shot trailing edge with control contact
- Es ON delay with control contact
- Wu Single shot leading edge voltage controlled
- Bp Flasher pause first
- Wt Pulse sequence monitoring

PDI20F

- lp Asymmetric flasher pause first
- li Asymmetric flasher pulse first
- ER On delay and off delay with control input
- EWs On delay and single shot leading edge with control input
- EWu On delay and single shot leading edge voltage controlled

PDM11

- 1 delayed contact (S1-S3-S4) and 1 instantaneous contact (S8-S9-S11)
- E11 ON delay
- R11 OFF delay with control contact
- Ws11 Single shot leading edge with control contact
- Wa11 Single shot trailing edge with control contact
- Es11 ON delay with control contact
- Wu11 Single shot leading edge voltage controlled
- Bp11 Flasher pause first
- Wt11 Pulse sequence monitoring

2 delayed contacts

- E20 ON delay
- R20 OFF delay with control contact
- Ws20 Single shot leading edge with control contact
- Wa20 Single shot trailing edge with control contact
- Es20 ON delay with control contact
- Wu20 Single shot leading edge voltage controlled
- Bp20 Flasher pause first
- Wt20 Pulse sequence monitoring

PDM20F (110-240V~)

PDM20F (24V)

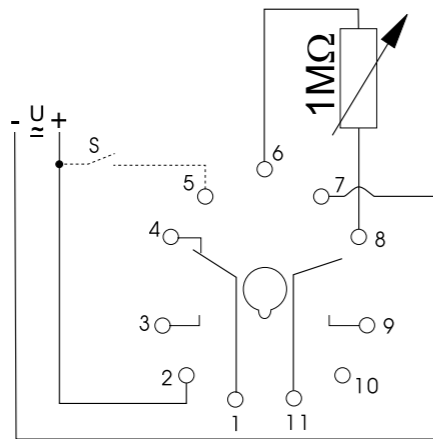
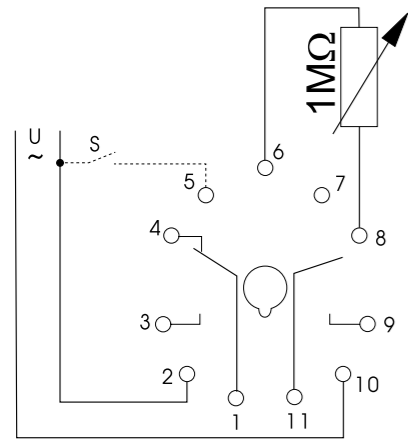

PDM11 (110-240V~)

PDI20F (24V)

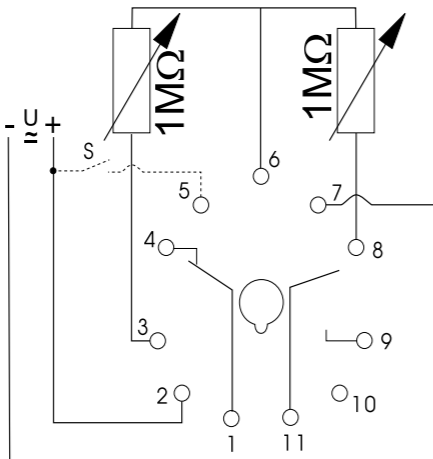
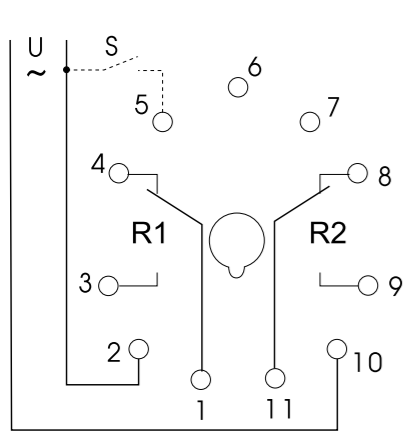

Width 38mm

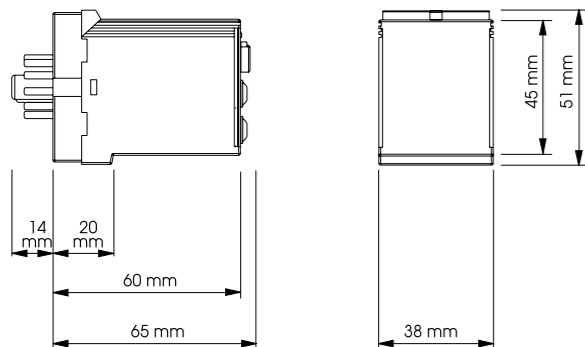

Functions



Time Relays Series ENYA

Multifunction Timer

- Multifunction
- 7 time ranges
- Zoom voltage 12 to 240V AC/DC or 24 to 240V AC/DC
- 1 CO contact (E1Z)
- 2 CO contacts (E3Z)
- Width 17,5mm and 35mm
- Installation design

Connections

types

| | E3ZM20 12-240V AC/DC | E1ZM10 12-240V AC/DC | E1ZM10 24-240V AC/DC | E1ZMW10 24-240V AC/DC | E1ZMQ10 24-240V AC/DC |
|-----------------------------|--|--|--|--|--|
| Art.No. (PQ1) | 111100 | 110100 | 110200 | - | 110202 |
| Art.No. (PQ10) | - | 110100A | 110200A | 110206A | 110202A |
| EAN13-Code | 900866200019 | 900866200009 | 900866200012 | 900866200521 | 900866200014 |
| Controls | Time • Function | Time • Function | Time • Function | Time • Function | Time • Function |
| Indicators (LEDs) | U/t • R | U/t • R | U/t • R | U/t • R | U/t • R |
| Functions | E • R • Ws • Wa • Es • Wu • Bp | E • R • Ws • Wa • Es • Wu • Bp | E • R • Ws • Wa • Es • Wu • Bp | E • R • Ws • Wa • WsWa • Wu • Wt | E • R • Wu • Bp |
| Inst. contact | - | - | - | - | - |
| 2-time function | - | - | - | - | - |
| Time ranges | 1 • 10s 1 • 10min 1 • 10h • 100h | 1 • 10s 1 • 10min 1 • 10h • 100h | 1 • 10s 1 • 10min 1 • 10h • 100h | 1 • 10s 1 • 10min 1 • 10h • 100h | 1 • 10s 1 • 10min 1 • 10h • 100h |
| Adjustment range | 5% to 100% | 5% to 100% | 5% to 100% | 5% to 100% | 5% to 100% |
| Control input | terminals A1-B1 loadable | Terminals A1-B1 loadable | terminals A1-B1 selectable | terminals A1-B1 loadable | terminals A1-B1 loadable |
| Remote potentiometer Supply | - | - | - | - | - |
| Output | 2 CO contacts 250V, 8A AC | 1 CO contact 250V, 8A AC | 1 CO contact 250V, 8A AC | 1 CO contact 250V, 8A AC | 1 CO contact 250V, 8A AC |
| Width | 35mm | 17,5mm | 17,5mm | 17,5mm | 17,5mm |
| Certificates | CE • cULus • GOST | CE • cULus • GOST | CE • cULus • GOST | CE • cULus • GOST | CE • cULus • GOST |
| Mechanical design | Self-extinguishing plastic housing, IP rating IP40 • Mounted on DIN-Rail TS 35 in accordance with EN 60715 • Mounting position any • Shockproof terminal connection according to VBG 4 (PZ1 required), IP rating IP20 • Tightening torque max. 1Nm | | | | |
| Terminal capacity | 1 x 0,5 to 2,5mm ² with/without multicore cable end • 1 x 4mm ² without multicore cable end • 2 x 0,5 to 1,5mm ² with/without multicore cable end • 2 x 2,5mm ² flexible without multicore cable end | | | | |
| Ambient conditions | Ambient temperature: -25 to +55°C (in accordance with IEC 60068-1) • Storage temperature: -25 to +70°C • Transport temperature: -25 to +70°C • relative humidity: 15% to 85% (in accordance with IEC 60721-3-3 class 3K3) • Pollution degree: 2 (in accordance with IEC 60664-1) | | | | |
| Accessories | - | | | | |

Dimensions

- E ON delay
- R OFF delay with control input
- Ws Single shot leading edge with control input
- Wa Single shot trailing edge with control input
- Es ON delay with control input
- Wu Single shot leading edge voltage controlled
- Bp Flasher pause first
- WsWa Single shot leading edge and single shot trailing edge with control input
- Wt Pulse sequence maintaining

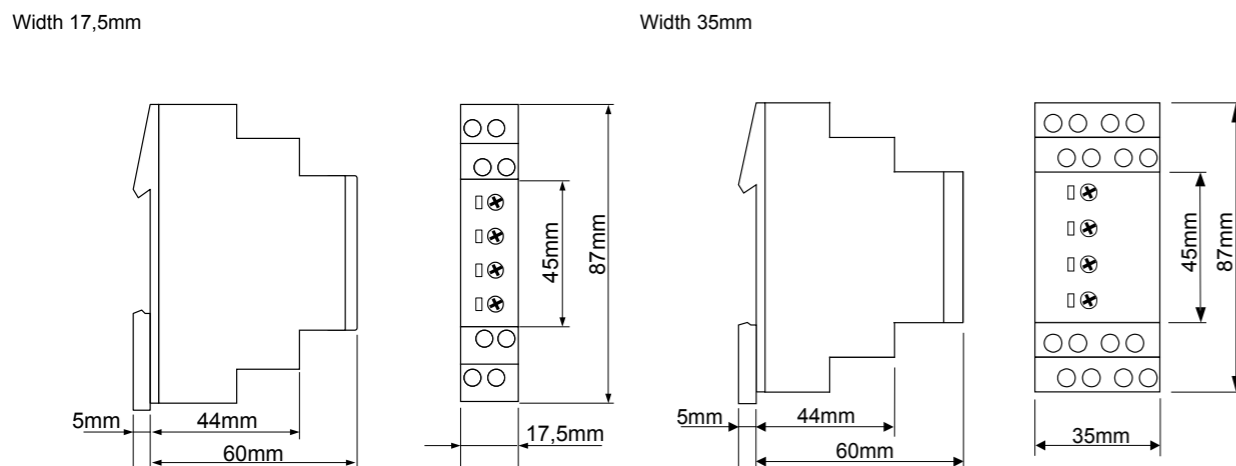
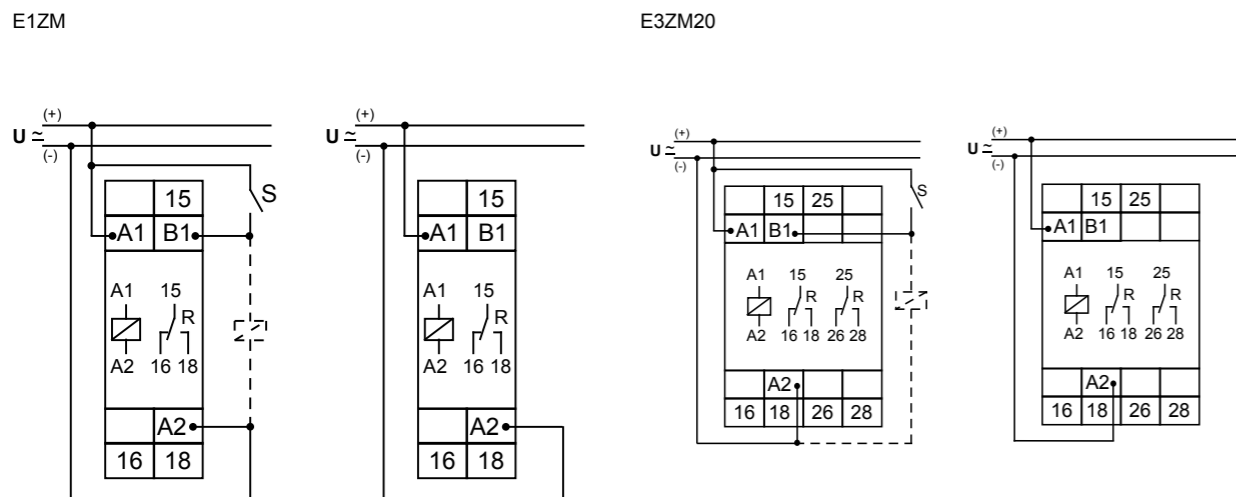

Functions



Time Relays Serie ENYA

Singlefunction

- Singlefunction
- 7 time ranges
- Zoom voltage 24 to 240V AC/DC
- 1 CO contact
- Width 17,5mm
- Installation design



Connections

types E1Z1E10 24-240V AC/DC E1Z1R10 24-240V AC/DC E1Z1ER10 24-240V AC/DC



| | | | |
|----------------------|--|---------------------------------------|---------------------------------------|
| Art.No. (PQ1) | - | - | - |
| Art.No. (PQ10) | 110204A | 110205A | 110208A |
| EAN13-Code | 9008662000162 | 9008662006065 | 9008662006270 |
| Controls | Time | Time | Time |
| Indicators (LEDs) | U/t • R | U/t • R | U/t • R |
| Functions | E | R | ER |
| Inst. contact | - | - | - |
| 2-time function | - | - | ja |
| Time ranges | 1 • 10s 1 • 10min 1 • 10 • 100h | 1 • 10s 1 • 10min 1 • 10 • 100h | 1 • 10s 1 • 10min 1 • 10 • 100h |
| Adjustment range | 5% to 100% | 5% to 100% | 5% to 100% |
| Control input | - | terminals A1-B1 loadable | terminals A1-B1 loadable |
| Remote potentiometer | - | - | - |
| Supply | 24 to 240V AC/DC terminals A1-A2 | 24 to 240V AC/DC terminals A1-A2 | 24 to 240V AC/DC terminals A1-A2 |
| Output | 1 CO contact 250V, 8AAC | 1 CO contact 250V, 8AAC | 1 CO contact 250V, 8AAC |
| Width | 17,5mm | 17,5mm | 17,5mm |
| Certificates | CE • cULus • GOST | CE • cULus • GOST | CE • cULus • GOST |
| Mechanical design | Self-extinguishing plastic housing, IP rating IP40 • Mounted on DIN-Rail TS 35 in accordance with EN 60715 • Mounting position any • Shockproof terminal connection according to VBG 4 (PZ1 required), IP rating IP20 • Tightening torque max. 1Nm | | |
| Terminal capacity | 1 x 0,5 to 2,5mm ² with/without multicore cable end • 1 x 4mm ² without multicore cable end • 2 x 0,5 to 1,5mm ² with/without multicore cable end • 2 x 2,5mm ² flexible without multicore cable end | | |
| Ambient conditions | Ambient temperature: -25 to +55°C (in accordance with IEC 60068-1) • Storage temperature: -25 to +70°C • Transport temperature: -25 to +70°C • relative humidity: 15% to 85% (in accordance with IEC 60721-3-3 class 3K3) • Pollution degree: 2 (in accordance with IEC 60664-1) | | |
| Accessories | - | | |

Dimensions

E ON delay
 R OFF delay with control input
 ER On delay and off delay with control input

E1Z

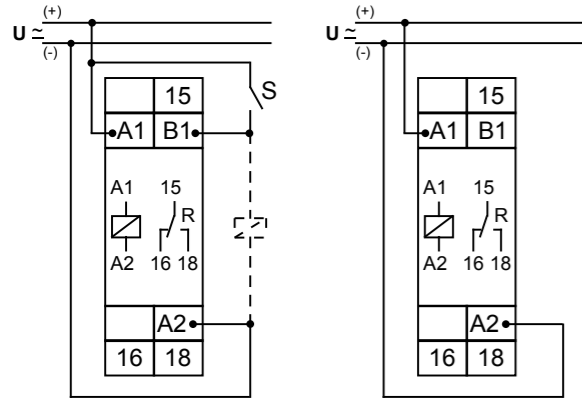

Width 17,5mm

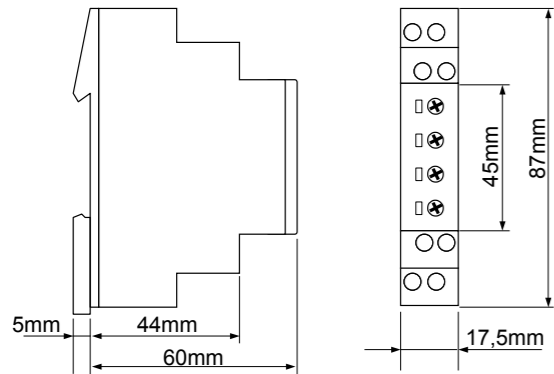

Functions



Time Relays Series ENYA

2-Time Multifunction Timer

- Asymmetric flasher (E1Z)
- 2-time multifunction (E3Z)
- 7 time ranges
- Zoom voltage 12 to 240 V AC/DC
- 1 CO contact (E1Z); 2 CO contacts (E3Z)
- Width 17,5mm; 35mm
- Installation design



Connections

types

E1ZI10 12-240V AC/DC

E3ZI20 12-240V AC/DC



Art.No. (PQ1)

110101

111101

Art.No. (PQ10)

-

-

EAN13-Code

900866200011

900866200020

Controls

Time 1 • Time 2

Time 1 • Time 2 • Function

Indicators (LEDs)

U/t • R

U/t • R

Functions

Ip • li (wire link A1-B1)

Ip • li • ER • EWu • EWs • WsWa • Wt

Inst. contact

-

-

2-time function

yes

yes

Time ranges

1 • 10s
 1 • 10min
 1 • 10h • 100h

1 • 10s
 1 • 10min
 1 • 10h • 100h

Adjustment range

5% to 100%

5% to 100%

Control input

-

terminals A1-B1
 loadable

Remote potentiometer

-

-

Supply

12 to 240V AC/DC
 terminals A1-A2

12 to 240V AC/DC
 terminals A1-A2

Output

1 CO contact
 250V, 8AAC

2 CO contacts
 250V, 8AAC

Width

17,5mm

35mm

Certificates

CE • cULus • GOST

CE • cULus • GOST

Mechanical design

Self-extinguishing plastic housing, IP rating IP40 • Mounted on DIN-Rail TS 35 in accordance with EN 60715 • Mounting position any • Shockproof terminal connection according to VBG 4 (PZ1 required), IP rating IP20 • Tightening torque max. 1Nm

Terminal capacity

1 x 0,5 to 2,5mm² with/without multicore cable end • 1 x 4mm² without multicore cable end • 2 x 0,5 to 1,5mm² with/without multicore cable end • 2 x 2,5mm² flexible without multicore cable end

Ambient conditions

Ambient temperature: -25 to +55°C (in accordance with IEC 60068-1) • Storage temperature: -25 to +70°C • Transport temperature: -25 to +70°C • relative humidity: 15% to 85% (in accordance with IEC 60721-3-3 class 3K3) • Pollution degree: 2 (in accordance with IEC 60664-1)

Accessories

-

Dimensions

| | |
|------|--|
| lp | Asymmetric flasher pause first |
| li | Asymmetric flasher pulse first |
| ER | ON delay and OFF delay with control contact |
| EWu | ON delay single shot leading edge voltage controlled |
| EWs | ON delay single shot leading edge with control contact |
| WsWa | Single shot leading and single shot trailing edge with control contact |
| Wt | Pulse sequence monitoring |

E1Z110

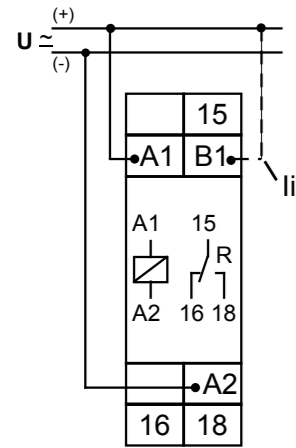

E3Z120

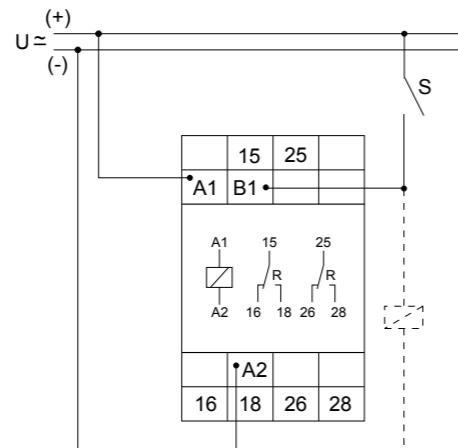

Width 17,5mm

Width 35mm

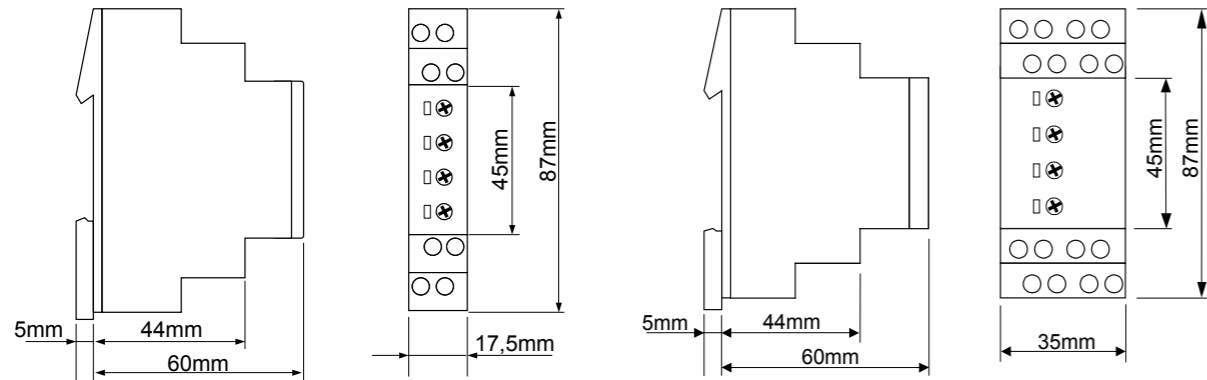

Functions



Time Relays Series ENYA

Star-Delta Timer

- Star-Delta start-up
- 4 time ranges (star-time)
- Selectable transit time
- Zoom voltage 12 to 240V AC/DC
- 2 CO contacts
- Width 35mm
- Installation design

Connections

types

E3ZS20 12-240V AC/DC



Art.No. (PQ1)

111300

Art.No. (PQ10)

-

EAN13-Code

900866200021

Controls

Time • Time Y → Δ

Indicators (LEDs)

U/t • R

Functions

S

Inst. contact

-

2-time function

-

Time ranges

Time Y: 10s • 30s • 1min • 3min
Time Y → Δ: 40ms • 60ms • 80ms • 100ms

Adjustment range

5% to 100% (Time Y)

Control input

-

Supply

12 to 240V AC/DC
terminals A1-A2

Output

2 CO contacts
250V, 8A AC

Width

35mm

Certificates

CE • cULus • GOST

Mechanical design

Self-extinguishing plastic housing, IP rating IP40 • Mounted on DIN-Rail TS 35 in accordance with EN 60715 • Mounting position any • Shockproof terminal connection according to VBG 4 (PZ1 required), IP rating IP20 • Tightening torque max. 1Nm

Terminal capacity

1 x 0,5 to 2,5mm² with/without multicore cable end • 1 x 4mm² without multicore cable end • 2 x 0,5 to 1,5mm² with/without multicore cable end • 2 x 2,5mm² flexible without multicore cable end

Ambient conditions

Ambient temperature: -25 to +55°C (in accordance with IEC 60068-1) • Storage temperature: -25 to +70°C • Transport temperature: -25 to +70°C • relative humidity: 15% to 85% (in accordance with IEC 60721-3-3 class 3K3) • Pollution degree: 2 (in accordance with IEC 60664-1)

Accessories

-



E3ZS

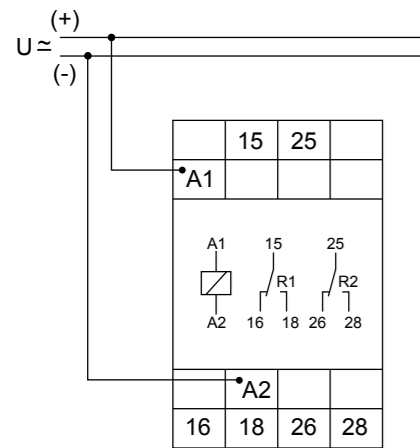

Width 35mm

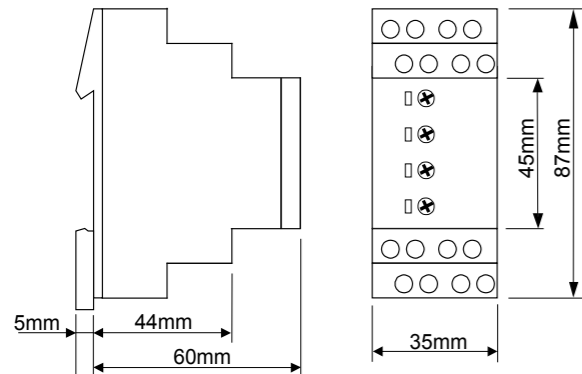

Functions



Time Relays Series ENYA

Light Controller



- Electronic staircase lighting timer with switch-off warning
- Retrigger, time extension and energy saving function programmable
- Impulse switch mode selectable
- Low switching noise
- High switching capacity, 80A peak inrush current
- Automatic 3/4 - wire detection
- Push-button glow lamp load up to 100mA
- Width 17,5mm
- Installation design

Connections

types

E1ZTPNC 230V AC

E1ZTP 230V AC

E1ZWI



Art.No. (PQ1)

110300

110301

110310

Art.No. (PQ10)

-

-

-

EAN13-Code

900866200017

900866200018

900866200506

Controls

Time • Function

Function/Time

Time

Indicators (LEDs)

U • R

U • R

U • R

Functions

TW • T • 1 • 0 • P • PN

TW • 1 • 0 • P

Wi

Inst. contact

-

-

-

2-time function

-

-

-

Time ranges

12min

12min

6min to 60min

Adjustment range

0,5 to 12min

0,5 to 12min

6min to 60min

Control input

terminal B1 (for pushbutton):
pushbutton B1-N (3-wire circuit)
pushbutton B1-L (4-wire circuit)
glow lamp load max. 100mA parallel to the
pushbuttons

terminal B1 (for pushbutton):
pushbutton B1-N (3-wire circuit)
pushbutton B1-L (4-wire circuit)
glow lamp load max. 100mA parallel to the
pushbuttons

terminal B1 (for pushbutton):
pushbutton B1-N (3-wire circuit)
pushbutton B1-L (4-wire circuit)
glow lamp load max. 100mA parallel to the
pushbuttons

terminals C1-C2
(additional Control input):
voltage range 8..230V AC/DC
galvanic separated

Remote potentiometer

-

-

-

Supply

230V AC
terminals L-N230V AC
terminals L-N230V AC
terminals L-N

Output

1 NO contact (terminals L-18)
250V, 16A AC1 NO contact (terminals L-18)
250V, 16A AC1 NO contact (terminals L-18)
250V, 16A AC

Width

17,5mm

17,5mm

17,5mm

Certificates

CE • cULus • GOST

CE • cULus • GOST

CE • cULus • GOST

Mechanical design

Self-extinguishing plastic housing, IP rating IP40 • Mounted on DIN-Rail TS 35 in accordance with EN 60715 • Mounting position any • Shockproof terminal connection according to VBG 4 (PZ1 required), IP rating IP20 • Tightening torque max. 1Nm

Terminal capacity

1 x 0,5 to 2,5mm² with/without multicore cable end • 1 x 4mm² without multicore cable end • 2 x 0,5 to 1,5mm² with/without multicore cable end • 2 x 2,5mm² flexible without multicore cable end

Ambient conditions

Ambient temperature: -25 to +55°C (in accordance with IEC 60068-1) • Storage temperature: -25 to +70°C • Transport temperature: -25 to +70°C • relative humidity: 15% to 85% (in accordance with IEC 60721-3-3 class 3K3) • Pollution degree: 2 (in accordance with IEC 60664-1)

Accessories

-

Electronic staircase lighting timer with switch-off warning. The control input allows the connection of pushbuttons with a total glow lamp load up to 100mA and enables the application in 3- or 4-wire circuits. The unit can be retriggered via the connected pushbuttons. A long keypress will switch off the light (energy saving function). A fast sequence of pushes (pumping) will extend the period to a multiple of the selected value. Depending upon distinct type, the following operating methods can be selected by the controls on the unit:

- TW Automatic timer with switch-off warning
- T Automatic timer without switch-off warning
- 1 Steady light (ON)
- 0 Switch-off
- P Impulse switch mode without time function (only types with option P)
- PN Impulse switch mode power fail latch (only types with option PN)
- Wi Impulse switch mode with off delay

For additional functions of control input (E1ZTPNC) refer to datasheet.

E1ZT (3-wire circuit)

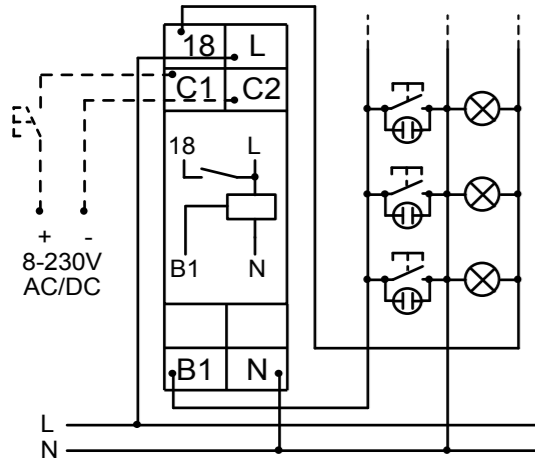

E1ZT (4-wire circuit with attic illumination)

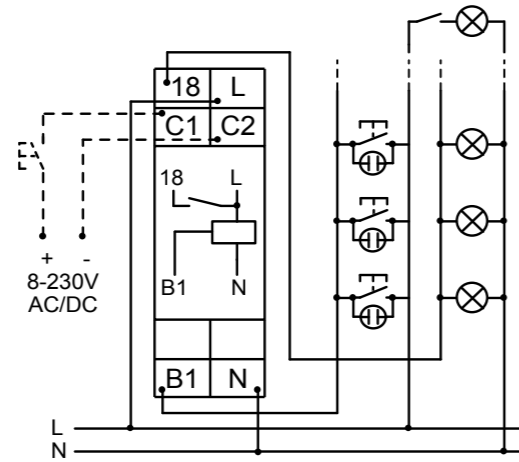

E1ZWI 3-wire-circuit

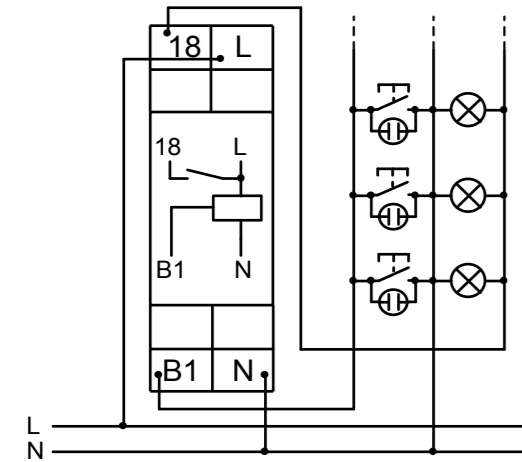

E1ZWI 4-wire-circuit with attic illumination

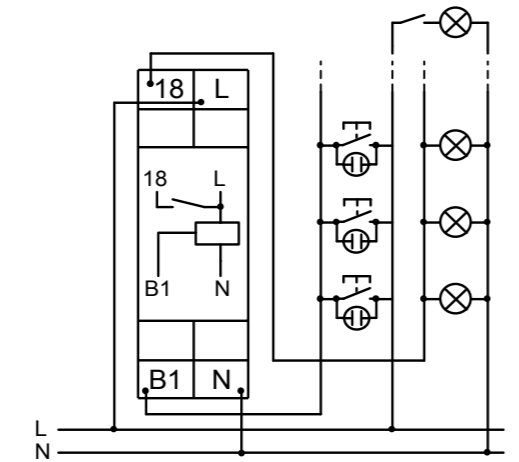

Width 17,5mm

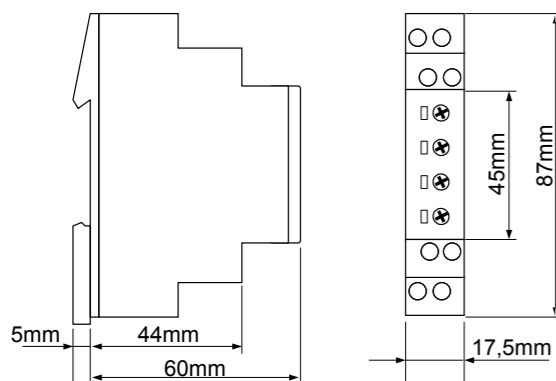

Functions



Time Relays Series ENYA

Emergency light tester

- Timer for automatic test of emergency light batteries
- Intergrated test button
- 1 CO contact
- Width 17,5mm
- Installation design

Connections

types

E1ZNT 230V AC



| | |
|--------------------|--|
| Art.No. (PQ1) | 110500 |
| Art.No. (PQ10) | - |
| EAN13-Code | 900866200586 |
| Controls | Time • Test |
| Indicators (LEDs) | U/t • R |
| Functions | Ws |
| Time ranges | 10min • 30min • 60min • 90min • 2h • 3h switchable |
| Control input | - |
| Supply | 230V AC terminals L-N |
| Output | 1 CO contact 250V, NC 16AAC; NO 5AAC |
| Width | 17,5mm |
| Certificates | CE • GOST |
| Mechanical design | Self-extinguishing plastic housing, IP rating IP40 • Mounted on DIN-Rail TS 35 in accordance with EN 60715 • Mounting position any • Shockproof terminal connection according to VBG 4 (PZ1 required), IP rating IP20 • Tightening torque max. 1Nm |
| Terminal capacity | 1 x 0,5 to 2,5mm ² with/without multicore cable end • 1 x 4mm ² without multicore cable end • 2 x 0,5 to 1,5mm ² with/without multicore cable end • 2 x 2,5mm ² flexible without multicore cable end |
| Ambient conditions | Ambient temperature: -25 to +55°C (in accordance with IEC 60068-1) • Storage temperature: -25 to +70°C • Transport temperature: -25 to +70°C • relative humidity: 15% to 85% (in accordance with IEC 60721-3-3 class 3K3) • Pollution degree: 2 (in accordance with IEC 60664-1) |
| Accessories | - |

Dimensions

Ws Single shot leading edge with control contact

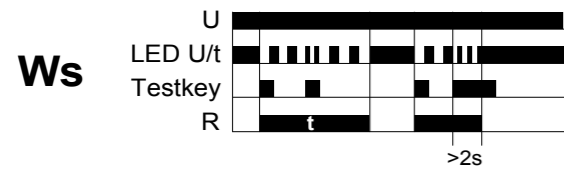

Direct connection of emergency lights (I < 16A)

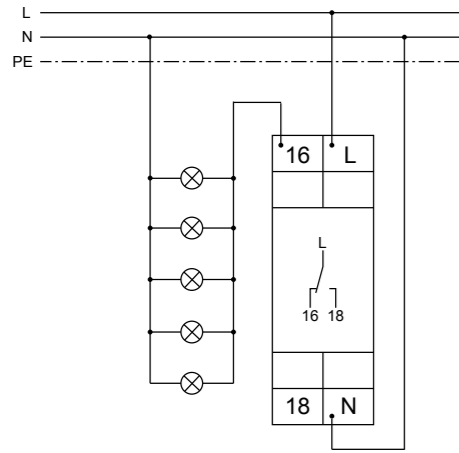

Switching emergency lights with contactor (I > 16A)

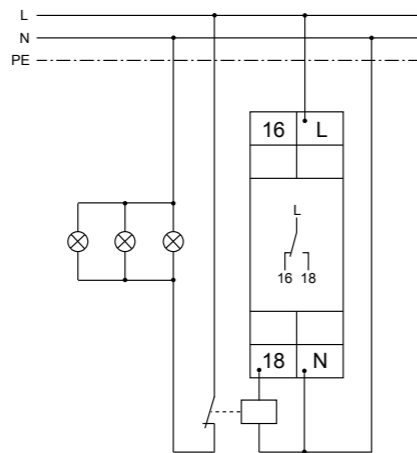

Width 17,5mm

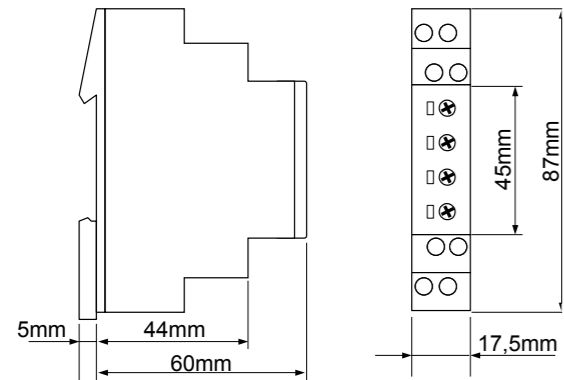

Functions



Time Relays Series FRONT

Multifunction Timer



- 8 Functions
- Digital time setting from 0,001s to 999,9h
- Supply voltage 24V AC/DC or 100-240V AC
- 1 CO contact
- Width 48mm
- Front panel mounting (aperture 45mm x 45mm)

Connections

types

FSM10 24V AC/DC

FSM10 100-240V AC



Art.No. (PQ1)

180600

180601

Art.No. (PQ10)

-

-

EAN13-Code

9008662

9008662

Controls

buttons for programming

buttons for programming

Indicators (LEDs)

Display

Display

Functions

functions refer to datasheet

functions refer to datasheet

Inst. contact

-

-

2-time function

-

-

Time ranges

digital adjustment

digital adjustment

Adjustment range

0,001 to 999,9h

0,001 to 999,9h

Control input

signal input pin 3-6
stop input pin 3-5
reset input pin 3-7
keylock input pin 3-4

signal input pin 3-6
stop input pin 3-5
reset input pin 3-7
keylock input pin 3-4

Remote potentiometer

-

-

Supply

24V AC/DC
pins 2-10

100 to 240V AC
pins 2-10

Output

1 CO contact
250V, 5A AC

1 CO contact
250V, 5A AC

Width

48mm

48mm

Certificates

CE • UR • cUR • GOST

CE • UR • cUR • GOST

Mechanical design

Self-extinguishing plastic housing, IP rating IP66 • Mounted in front panel aperture 45mm x 45mm by means of retaining clip (included) in accordance with DIN 43700 • Mounting position any

Ambient conditions

Ambient temperature: -10 to +55°C • Storage temperature: -10 to +70°C • Transport temperature: -10 to +70°C • relative humidity: 15% to 85% (in accordance with IEC 60721-3-3 class 3K3) • Pollution degree: 2, if built in 3 (in accordance with IEC 60664-1)

Accessories

AZ511, R11X

Dimensions

- A ON delay
- A2 ON delay with power failure detection
- B ON delay with control contact
- C OFF delay with control contact
- D Single shot leading edge with control contact
- E ON delay pulse operated
- F Flasher pause first
- G ON delay with control contact, adding, power failure

FSM10

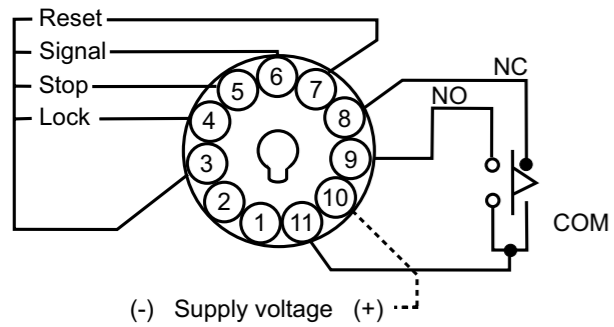

Width 48mm

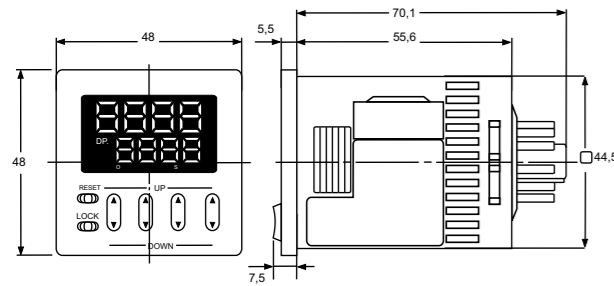

Functions



Time Relays Series COMBI

Multifunction Timing Module



- Timing modul for industrial relays
- 8 Functions
- 8 time ranges
- Supply voltage through zoom voltage 24-240V AC/DC (must match to used relay)
- Solid state output to control the connected industrial relay
- Width 35mm
- Combination only with industrial relays Series RT and socket types ES9 or PF-113BE/M

Connections

types

COM3TP 24-240V AC/DC



Art.No. (PQ1)

237010

Art.No. (PQ10)

-

EAN13-Code

900866200202

Controls

Time • Function

Indicators (LEDs)

U/t

Functions

E • R • Ws • Wa • Wu • Es • Bp • Bi

Inst. contact

-

2-time function

-

Time ranges

1 • 10s
1 • 10min
1 • 10h
1 • 10d

Adjustment range

5% to 100%

Control input

terminals A1-B1
loadable

Remote potentiometer

-

Supply

24 to 240V AC/DC
terminals A1-A2

Output

2 or 3 CO contacts, Industrial relays

Width

35mm

Certificates

CE • GOST

Mechanical design

Self-extinguishing plastic housing, IP rating IP40 • Connection and mounting by 11-pin socket in accordance with IEC 60067-1-18a (types ES9 or PF-113BE/M) • Mounting position any

Ambient conditions

Ambient temperature: -25 to +55°C (in accordance with IEC 60068-1) • Storage temperature: -25 to +70°C • Transport temperature: -25 to +70°C • relative humidity: 15% to 85% (in accordance with IEC 60721-3-3 class 3K3) • Pollution degree: 2, if built in 3 (in accordance with IEC 60664-1)

Accessories

Socket ES9 and PF-113BE/M; industrial relays RT

Dimensions

| | |
|----|--|
| E | ON delay |
| R | OFF delay with control contact |
| Ws | Single shot leading edge with control contact |
| Wa | Single shot trailing edge with control contact |
| Wu | Single shot leading edge voltage controlled |
| Es | ON delay with control contact |
| Bp | Flasher pause first |
| Bi | Flasher pulse first |

COM3T + RTx.x.xxx + PF-113BE/M

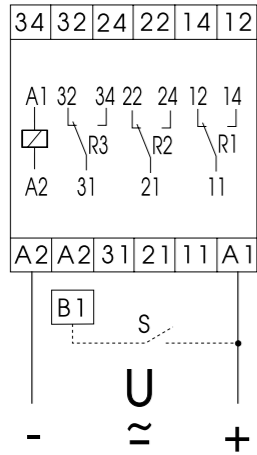

Width 35mm

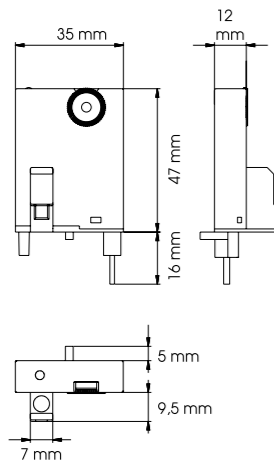

Functions



Time Relays Series RONDO

Timer with solid state output



- ON delay
- 1 time range
- Transistor output
- Diameter 28mm
- Front panel mounting

Connections

| | | | | | | |
|-------|-------------------------|-------------------------|--------------------------|-------------------------|--------------------------|--------------------------|
| types | SRE2-PNP 1SEC 24V DC | SRE2-PNP 3SEC 24V DC | SRE2-PNP 10SEC 24V DC | SRE2-PNP 1MIN 24V DC | SRE2-PNP 10MIN 24V DC | SRE2-PNP 60MIN 24V DC |
|-------|-------------------------|-------------------------|--------------------------|-------------------------|--------------------------|--------------------------|



| | | | | | | |
|----------------------|---|--------------|--------------|--------------|--------------|--------------|
| Art.No. (PQ1) | 237060 | 237066 | 237061 | 237062 | 237063 | 237064 |
| Art.No. (PQ10) | - | - | - | - | - | - |
| EAN13-Code | 900866200208 | 900866200213 | 900866200209 | 900866200210 | 900866200211 | 900866200212 |
| Controls | Time | Time | Time | Time | Time | Time |
| Indicators (LEDs) | U • R | U • R | U • R | U • R | U • R | U • R |
| Functions | E | E | E | E | E | E |
| Inst. contact | - | - | - | - | - | - |
| 2-time function | - | - | - | - | - | - |
| Time ranges | 1s | 3s | 10s | 1min | 10min | 60min |
| Adjustment range | 10% to 100% | 10% to 100% | 10% to 100% | 10% to 100% | 10% to 100% | 10% to 100% |
| Control input | - | - | - | - | - | - |
| Remote potentiometer | - | - | - | - | - | - |
| Supply | 24V DC terminals 2-3 | | | | | |
| Output | 1 transistor 6W (200mA / 30V) integrated overcurrent protection | | | | | |
| Width | diameter 28mm | | | | | |
| Certificates | CE • GOST | | | | | |
| Mechanical design | Self-extinguishing plastic housing, IP rating IP64 (frontside) • Mounted in front panel aperture clear diameter 22.5mm by means of retaining clip (included) in accordance with DIN 43700 • Mounting position any • Shockproof terminal connection according to VBG 4, Schutzart IP10 • Tightening torque max 1Nm | | | | | |
| Terminal capacity | 1 x 0,5 to 1mm ² with/without multicore cable end | | | | | |
| Ambient conditions | Ambient temperature: -25 to 55°C (in accordance with IEC 60068-1) • Storage temperature: -25 to +65°C • Transport temperature: -25 to +65°C • relative humidity: 15% to 85% (in accordance with IEC 60721-3-3 class 3K3) • Pollution degree: 3 (in accordance with IEC 60664-1) | | | | | |
| Accessories | - | | | | | |

Dimensions

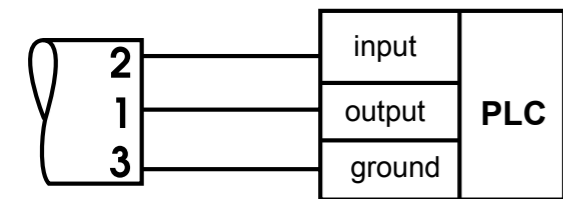
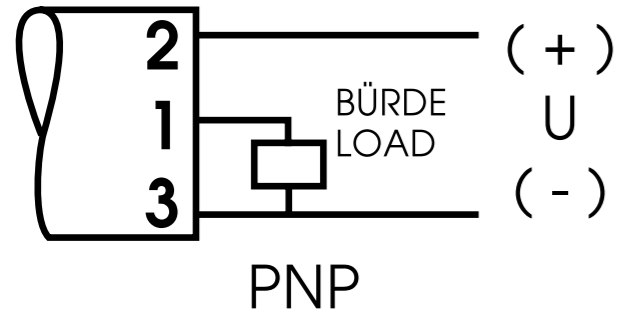

diameter 28mm

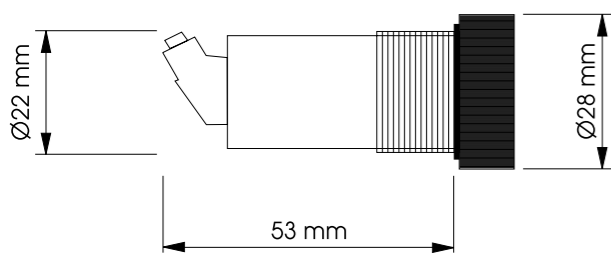

Functions



Time Relays Series RONDO

Timer with solid state output

- Single shot leading edge voltage controlled
- 1 Time range
- Transistor output
- Front panel mounting
- Diameter 28mm



Connections

types

| SRW2-PNP 1SEC 24V DC | SRW2-PNP 10SEC 24V DC | SRW2-PNP 1MIN 24V DC | SRW2-PNP 10MIN 24V DC | SRW2-PNP 60MIN 24V DC |
|-------------------------|--------------------------|-------------------------|--------------------------|--------------------------|
|-------------------------|--------------------------|-------------------------|--------------------------|--------------------------|



| | SRW2-PNP 1SEC 24V DC | SRW2-PNP 10SEC 24V DC | SRW2-PNP 1MIN 24V DC | SRW2-PNP 10MIN 24V DC | SRW2-PNP 60MIN 24V DC |
|----------------------|---|--|--|--|--|
| Art.No. (PQ1) | 237080 | 237081 | 237082 | 237083 | 237084 |
| Art.No. (PQ10) | - | - | - | - | - |
| EAN13-Code | 900866200217 | 900866200218 | 900866200219 | 900866200220 | 900866200221 |
| Controls | Time | Time | Time | Time | Time |
| Indicators (LEDs) | U • R | U • R | U • R | U • R | U • R |
| Functions | Wu | Wu | Wu | Wu | Wu |
| Inst. contact | - | - | - | - | - |
| 2-time function | - | - | - | - | - |
| Time ranges | 1s | 10s | 1min | 10min | 60min |
| Adjustment range | 10% to 100% | 10% to 100% | 10% to 100% | 10% to 100% | 10% to 100% |
| Control input | - | - | - | - | - |
| Remote potentiometer | - | - | - | - | - |
| Supply | 24V DC terminals 2-3 | 24V DC terminals 2-3 | 24V DC terminals 2-3 | 24V DC terminals 2-3 | 24V DC terminals 2-3 |
| Output | 1 transistor 6W (200mA / 30V) integrated overcurrent protection | 1 transistor 6W (200mA / 30V) integrated overcurrent protection | 1 transistor 6W (200mA / 30V) integrated overcurrent protection | 1 transistor 6W (200mA / 30V) integrated overcurrent protection | 1 transistor 6W (200mA / 30V) integrated overcurrent protection |
| Width | diameter 28mm | diameter 28mm | diameter 28mm | diameter 28mm | diameter 28mm |
| Certificates | CE • GOST | CE • GOST | CE • GOST | CE • GOST | CE • GOST |
| Mechanical design | Self-extinguishing plastic housing, IP rating IP64 (frontside) • Mounted in front panel aperture clear diameter 22.5mm by means of retaining clip (included) in accordance with DIN 43700 • Mounting position any • Shockproof terminal connection according to VBG 4, Schutzart IP10 • Tightening torque max 1Nm | | | | |
| Terminal capacity | 1 x 0,5 to 1mm ² with/without multicore cable end | | | | |
| Ambient conditions | Ambient temperature: -25 to 55°C (in accordance with IEC 60068-1) • Storage temperature: -25 to +65°C • Transport temperature: -25 to +65°C • relative humidity: 15% to 85% (in accordance with IEC 60721-3-3 class 3K3) • Pollution degree: 3 (in accordance with IEC 60664-1) | | | | |
| Accessories | - | | | | |

Connections

Dimensions

- Terminal capacity
- Ambient conditions
- Accessories

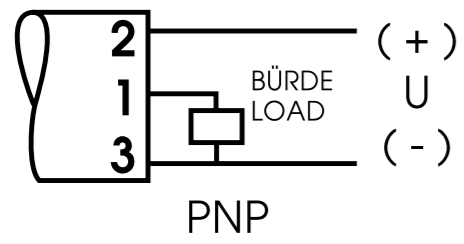

diameter 28mm

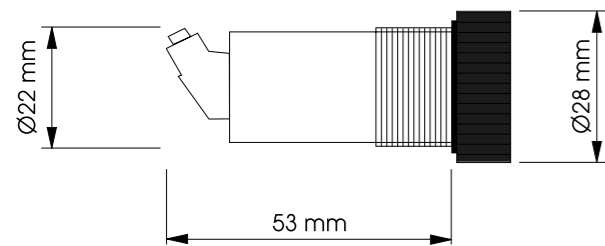

MONITORING SYSTEMS



OVERVIEW



Monitoring Systems



WatchDog pro is a modular, industry-compliant monitoring system that combines classical monitoring and time-related functions with the communication potential of fieldbuses, SMS and e-mail. The central control unit makes the system intelligent, so that sophisticated monitoring and automation functions can also be implemented. WatchDog pro combines the flexibility of SPC with a robust monitoring system for industrial applications.

| | Page |
|------------------|------|
| Introduction | 158 |
| Selection Matrix | 162 |
| Modules | 163 |

Energy management ECO III

The consumption of energy as uniformly as possible throughout the day offers the supplier the prospect of considerable savings. Agreeing a peak load rate also gives the end consumer the opportunity to significantly reduce his energy costs.

201

Sequence controller STEP-T8

Periodic filter cleaning with compressed air, simple water treatment plants, feeding systems, lighting controls, up to 9 output channels are controlled in a timed sequence. No special programming knowledge is required to put the device into operation.

203

Pumpalternator

As a compact unit the pumpcontroller allot the feed of 2 pumps by alternating operation. According to requirments two different modes of parallel operation might be activated to cover high loads. Uniform load sharing and periodical operation of both pump sets are the best condition for operational readiness.

205

**MORE THAN
THE SUM OF
INDIVIDUAL
SENSOR RELAYS**

WatchDog pro is a modular, industry-compliant monitoring system that combines classical monitoring and time-related functions with the communication potential of fieldbuses, SMS and e-mail. The central control unit makes the system intelligent, so that sophisticated monitoring and automation functions can also be implemented. As the problem solver for stationary and mobile applications in the mechanical engineering field as well as for industrial and building systems, *WatchDog pro* combines the flexibility of PLC with a robust monitoring system for industrial applications. Thanks to its withstand voltage, clearances, creepage distances

and rated surge voltage it can perform under the harshest industrial conditions. Its modular design will bring end-to-end advantages from planning through power-on to plant expansion. *WatchDog pro* is thus above the equipment class to which classical time and monitoring relays belong. The monitoring functions for current, voltage, phase sequence, phase failure, active power and temperature have been combined into an integrated, modular monitoring scheme with a system application in mind. By combining all necessary monitoring and control functions it meets the requirements placed on an automation system.

An integral component of the central control unit is the datalogger. Supported by *WatchDog pro*, plant and system data can be logged on a memory card and used for high-speed evaluating. Forming another part of an efficient maintenance management system, the interfaces (fieldbuses, web server, SMS) will allow simple remote maintenance as well as integration into a more comprehensive process control system. *WatchDog pro* is a quantum leap in the field of monitoring technology, building on the long-established TELE products of the GAMMA industrial series. Typical applications are to be found in the areas of water supply and waste water disposal,

power distribution as well as heating, ventilation and air conditioning. The system's modular design and industry compliance make it perfectly suitable for monitoring small and medium-sized machines and plant as well as for use in the process industry.

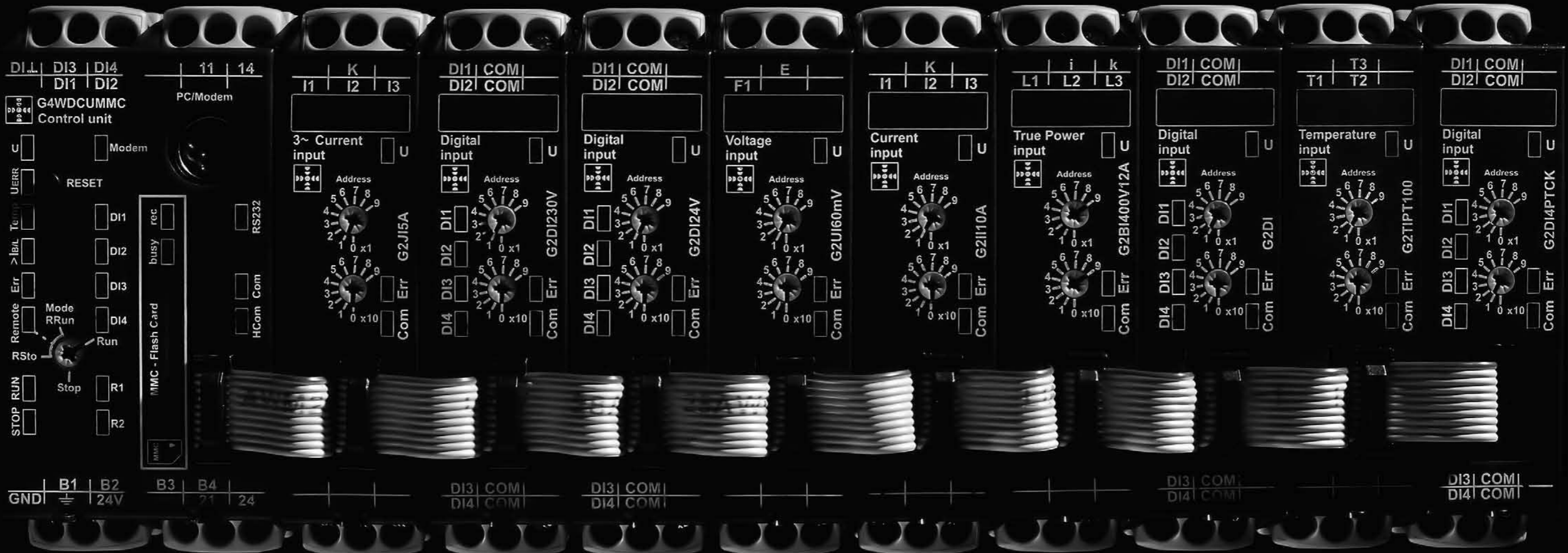

COMMUNICATION

WatchDog pro's parameters are set using a clearly arranged software interface. Plant documentation can be produced at the press of a button from the annotated function list. Communication takes place via a serial interface or over the net using a web server (LAN or WAN).

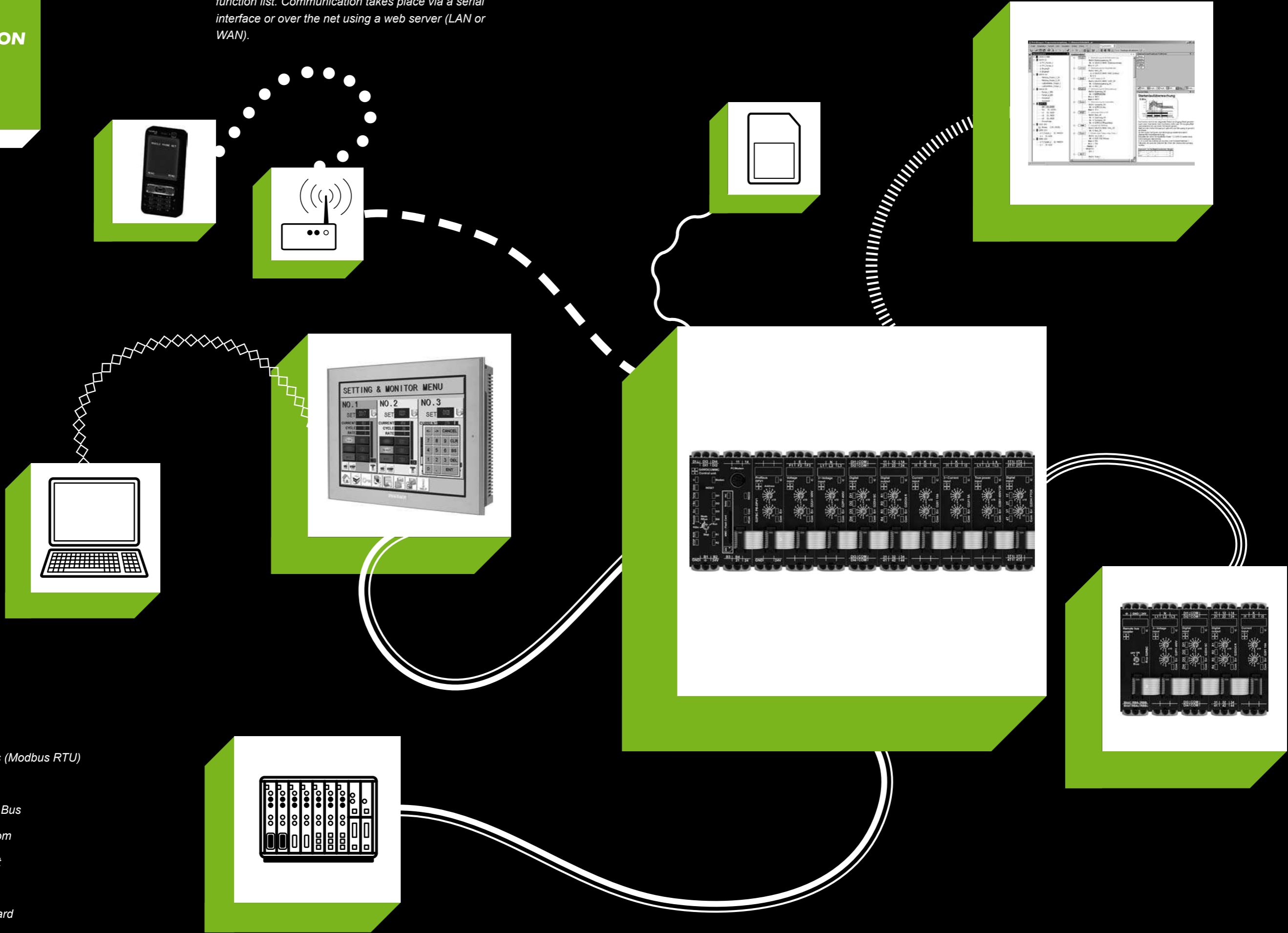

- Fieldbus (Modbus RTU)
- RS232
- Remote Bus
- WDP Com
- Ethernet
- SMS
- MMC Card

OVERVIEW

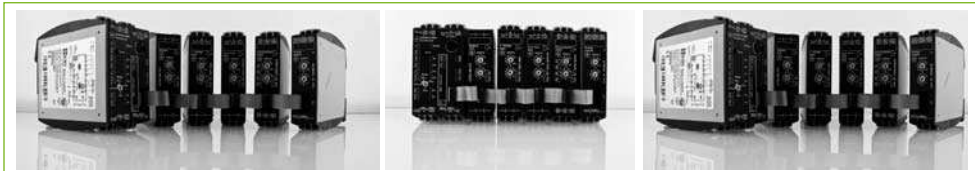

WatchDog pro Module

Measuring modules

| Measured variable | | Measured range | Type | Page |
|-------------------|--|---|---------------|------|
| Voltage | 1-phase | 60mV; 150mV; 10V AC/DC (16,6 - 400Hz) | G2UI1 10V | 163 |
| | | 30V; 60V; 300V AC/DC (16,6 - 400Hz) | G2UI1 300V | 165 |
| | 3-phase | 230/400V AC (48 - 63Hz) Phase sequence, asymmetry | G2PI1 400V | 167 |
| | | 277/480V AC (48 - 63Hz) Phase sequence, asymmetry | G2PI1 480V | 167 |
| | | 60mV AC/DC (Shunt measurement) | G2YI3 60mV | 169 |
| Current | 1-phase | 20mA; 1A; 5AAC/DC (16,6 - 400Hz) | G2II1 5A | 171 |
| | | 100mA; 1A; 10AAC/DC (16,6 - 400Hz) | G2II1 10A | 171 |
| | 3-phase | 5A AC (48 - 63Hz) (Common) | G2JI1 5A | 173 |
| | | 1A AC (48 - 63Hz) (Common) | G2JI1 1A | 173 |
| | | | | |
| Power | True power | 600W; 1200W; 2400W; 4800W (max. 12A) | G2BI1 400V12A | 175 |
| | True-, apparent-, reactive power; power factor | 1200W; 4800W (max. 12A) | G2CI1 400V12A | 177 |
| | PT100 / PT1000 Sensors (4-fold) | -100 to +300°C / -200 to +850°C | G2TI4 PT | 179 |

In-/ Outputs

| Module | Number | Type | Type | Page |
|------------------------------|---------------------|---|----------------|------|
| Digital input module | 4-point | 24V AC/DC (48 - 63Hz) | G2DI4 24V | 181 |
| | | 230V AC (48 - 63Hz) | G2DI4 230V | 181 |
| | | potential free inputs, NPN sensors | G2DI4 SC | 181 |
| | | PTC | G2DI4 PTCK | 183 |
| | 8-point | 24V DC | G2DI8 24V | 185 |
| Digital output module | 4-point | isolated relay contacts 250V AC | G2DO4 R | 187 |
| | | isolated PNP semiconductor outputs 24V DC | G2DO4 SP24VDC | 187 |
| | | isolated NPN semiconductor outputs 24V DC | G2DO4 SN24VDC | 187 |
| | 8-point | PNP semiconductor outputs 24VDC | G2DO8 SPC24VDC | 189 |
| | 4 Inputs / 1 Output | 0 - 10V; 4 - 20mA standard signals | G2AM4 M | 191 |

Central Unit

| | | | |
|------------|---|------------|-----|
| CPU | Central Unit with MMC Slot and GSM Modem driver | G4WDCU MMC | 163 |
|------------|---|------------|-----|

Communication

| | | | |
|---------------------------|---|---------------------|-----|
| Fieldbus module | Communication between the Central Unit and the process level via Modbus-RTU, Profibus-DP, DeviceNet, CANopen, Modbus-TCP, EtherNet/IP | G2FBC | 193 |
| Fieldbus gateway | Communication between WatchDog pro modules and the process level via Modbus-RTU, Profibus-DP, DeviceNet, CANopen, Modbus-TCP, EtherNet/IP | G2WDGW2 | 195 |
| Remote bus coupler | Distributed system enlargement | G2RBC | 197 |
| GSM-module | GSM Communications modules | WDP GSM DataCenter | 164 |
| GPRS-module | GPRS Communications modules | WDP GPRS DataCenter | 164 |

Accessories

| | | | |
|--|--|-----------------------|-----|
| Touchpanels | Display size from 3,4 to 10,4 Inch | AGP..., HSD..., GP... | 199 |
| MultiMediaCard™ (MMC) | Formatted MultiMediaCard™ for the datalogger function with 1 to 2GB memory | MMC | 164 |
| | MMC read out package including Datalogger software and MultiMediaCard Reader | MMC-Reader | 164 |
| Parameterisation software on CD, running on Windows 98 / ME / 2000 / XP / Vista | | WDP Soft | 164 |
| Communication equipment: USB serial converter and interface cable RS232 | | WDP COM | 164 |



WatchDog pro

Central Unit



- Information about the operating status (error, operation mode, status of In- and outputs, communication and datalogger)
- Selectable operation mode
- Recording of facility- and system data via MultiMediaCard™ (MMC™)
- Reinforced insulation of the input and output circuit
- 4 digital inputs
- 2 relay outputs
- Width 45mm
- Industrial design

Type

G4WDCU MMC



| | |
|---------------------|--|
| Art.No. (PQ1) | 2500000 |
| Art.No. (PQ10) | - |
| EAN13-Code | 900866200329 |
| Input circuit | Voltage AC/DC |
| Digital inputs | AC Sinus (48 to 63Hz) 24 to 230V AC • 24 to 100V DC (input activ) |
| Internal values | Device temperature • Current remote bus • Current local interface • Supply voltage • Battery voltage |
| Controls | RRun • RStop • Run • Stop |
| Indicators (LEDs) | U • U _{ERR} • Temp • I _{RB/LI} • Err • Remote • RUN • STOP • Modem • DI1 • DI2 • DI3 • DI4 • R1 • R2 • ready • busy • RS232 • HCom • Com |
| Datalogger | MMC |
| Businterface | Standard bus (RS485) |
| Communication | RS232 with PC • Modem |
| Remote bus | RS485 over RB _L , (RB+), RBA, RBB |
| Overvoltage cat. | III (in accordance with IEC 60664-1) |
| Rated surge voltage | 6kV |
| Registers | max. 845 |
| Permanent registers | 27 and 128 permanent boolean registers |
| Supply | 24VDC |
| Output | 2 NO contacts 250V AC, 3AAC |
| Width | 45mm |
| Certificates | CE • GOST |
| Mechanical design | Self-extinguishing plastic housing, IP rating IP20 • Mounted on DIN-rail TS 35 in accordance with EN 60715 • Mounting position: any • Shockproof terminal connection according to VBG 4 (PZ1 required), IP rating IP20 • Tightening torque: max. 1Nm |
| Terminal capacity | 1 x 0.5 to 2.5mm ² with/without multicore cable end • 1 x 4mm ² without multicore cable end • 2 x 0.5 to 1.5mm ² with/without multicore cable end • 2 x 2.5mm ² flexible without multicore cable end |
| Ambient conditions | Ambient temperature: -25 to +55°C (in accordance with IEC 60068-1); -25 to +40°C (in accordance with UL 508) • Storage temperature: -25 to +70°C • Transport temperature: -25 to +70°C • Relative humidity: 15% to 85% (in accordance with IEC 60721-3-3 class 3K3) • Absolute humidity: 1g to 25g H ₂ O/m ³ (in accordance with IEC 60721-3-3 class 3K3) • Pollution degree: 2 (in accordance with IEC 60664-1) • Vibration resistance: 10 to 55Hz 0.35mm (in accordance with IEC 60068-2-6) • Shock resistance: 15g 11ms (in accordance with IEC 60068-2-27) |
| Accessories | WDP SOFT • WDP COM • WDP GSM • MMC Card |

The user-defined program is stored and executed in the central unit (CU).
 The LED's provide information about the current operation status (error, mode of operation, status of in-/outputs, communication and data-logger) of the system. Facility- and system data are saved event-triggered on the MultiMediaCard™ (MMC™) by the usage of the datalogger. The operation mode can be chosen by the use of the mode selector with following settings:

| | |
|-------|--|
| RRun | Remote Run (program runs after reset, access of the programming environment to the Central unit is possible) |
| RStop | Remote Stop (program doesn't run after reset, access of the programming environment to the Central unit is possible) |
| Run | Program runs after reset, access of the programming environment to the Central unit is only possible to a limited degree, communication with modem |
| Stop | Program doesn't run after reset, access of the programming environment to the CU is only possible to a limited degree |

The firmware and applications can be updated via the software. The firmware and application update can also be performed by means of the MultiMediaCard™.

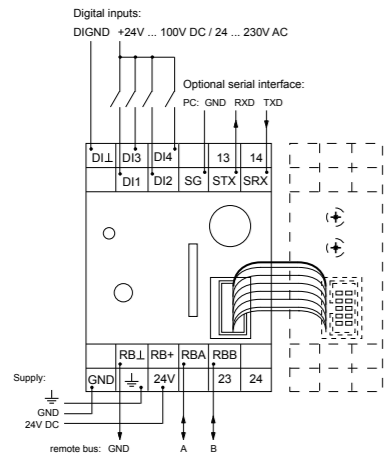

Width 45mm

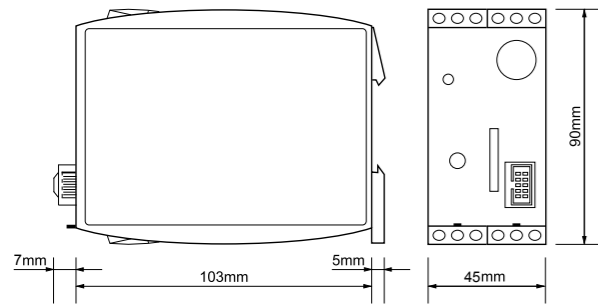

Accessories

| | | |
|---------------------------------|--|---------|
| G4NG230V24V2.5A | Power supply, 230VAC, 24VDC/2,5A, 1-phase | 2600000 |
| WDP SOFT | Parameterisation software Programming environment on CD, running on Windows 98/ME/2000/XP | 2500030 |
| MMC-READER | MMC read out package including Datalogger software and MMC Card Reader | 2500035 |
| WDP COM | Communication equipment WatchDog pro including USB serial converter and interface cable RS232 | 2500040 |
| WDP GSM Datacenter | WatchDog pro GSM Datensolution for the two-way communication | 2500046 |
| WDP GPRS Datacenter | WatchDog pro GPRS Datensolution for the two-way communication | 2500048 |
| WDP GSM | WatchDog pro GSM Package for the simple report of informations via SMS | 2500045 |
| MMC 1GB | MultiMediaCard 1GB (formatted memorycard) | 2500010 |
| MMC 2GB | MultiMediaCard 2GB (formatted memorycard) | 2500020 |
| STANDARD CABLE HMI/WDP RS485 5M | RS485 Standard connecting cable WDP/Touchpanel, display type LCD/STN/TFT | 2500894 |

Functions



WatchDog pro

Voltage monitoring in 1-phase mains



- Voltage measurement in 1-phase mains
- Measured range 10V for standard signal (G2UI1 10V)
- Measuring ranges for 30V, 60V and 300V (G2UI1 300V)
- Measuring ranges 60mV and 150mV for shunt measurement (G2UI1 10V)
- Reinforced insulation of the measuring circuit
- Measured value transmitting via standard bus
- Modular monitoring system
- Width 22,5mm
- Industrial design

Connections

Type

G2UI1 10V

G2UI1 300V



Art.No. (PQ1)

2500050

2500051

Art.No. (PQ10)

-

-

EAN13-Code

900866200523

900866200488

Measured variable

Voltage AC/DC
DC or AC Sinus (16,6 to 400Hz)

Voltage AC/DC
DC or AC Sinus (16,6 to 400Hz)

Measured ranges

60mV AC/DC; terminals E-F1(+)
150mV AC/DC; terminals E-F2(+)
10V AC/DC; terminals E-F3(+)

30V AC/DC; terminals E-F1(+)
60V AC/DC; terminals E-F2(+)
300V AC/DC; terminals E-F3(+)

Controls

Address adjustment:
Address range 1 to 99

Address adjustment:
Address range 1 to 99

Indicators (LEDs)

U • Err • Com

U • Err • Com

Businterface

Standard bus (RS485)

Standard bus (RS485)

Overvoltage cat.

III (in accordance with IEC 60664-1)

III (in accordance with IEC 60664-1)

Rated surge voltage

6kV

6kV

Supply

24V DC from local interface

24V DC from local interface

Output

-

-

Width

22,5mm

22,5mm

Certificates

CE • GOST

CE • GOST

Mechanical Design

Self-extinguishing plastic housing, IP rating IP20 • Mounted on DIN-rail TS 35 in accordance with EN 60715 • Mounting position: any • Shockproof terminal connection according to VBG 4 (PZ1 required), IP rating IP20 • Tightening torque: max. 1Nm

Terminal capacity

1 x 0.5 to 2.5mm² with/without multicore cable end • 1 x 4mm² without multicore cable end • 2 x 0.5 to 1.5mm² with/without multicore cable end • 2 x 2.5mm² flexible without multicore cable end

Ambient conditions

Ambient temperature: -25 to +55°C (in accordance with IEC 60068-1); -25 to +40°C (in accordance with UL 508) • Storage temperature: -25 to +70°C • Transport temperature: -25 to +70°C • Relative humidity: 15% to 85% (in accordance with IEC 60721-3-3 class 3K3) • Absolute humidity: 1g to 25g H₂O/m³ (in accordance with IEC 60721-3-3 class 3K3) • Pollution degree: 2 (in accordance with IEC 60664-1) • Vibration resistance: 10 to 55Hz 0.35mm (in accordance with IEC 60068-2-6) • Shock resistance: 15g 11ms (in accordance with IEC 60068-2-27)

Accessories

-



WatchDog pro

Voltage monitoring in 3-phase mains



- Voltage measurement in 3-phase mains for 3- and 4-wire circuit
- Connection of neutral conductor optional
- Monitoring of phase sequence and phase failure
- Monitoring of asymmetry
- Reinforced insulation of the measuring circuit
- Measured value transmitting via standard bus
- Modular monitoring system
- Width 22,5mm
- Industrial design

Measured ranges 60mV AC/DC

Measured ranges 150mV AC/DC

Measured ranges 10V AC/DC

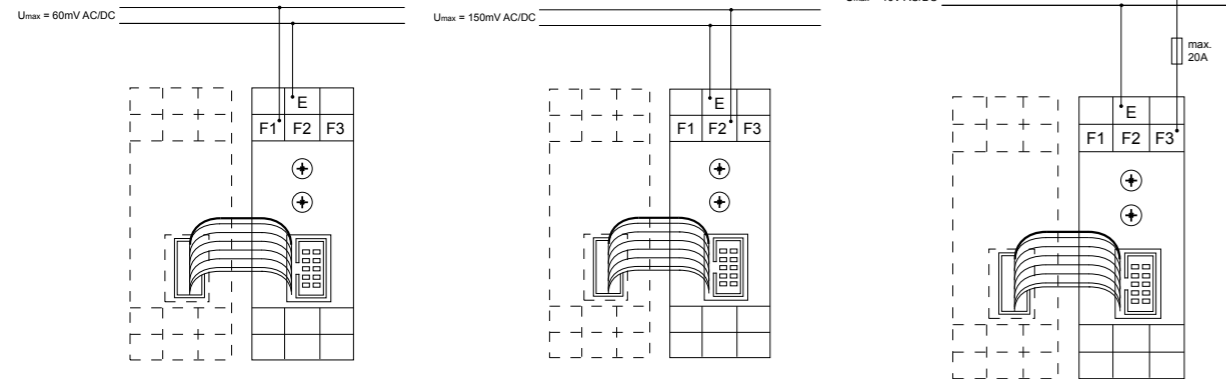

Measured ranges 30V AC/DC

Measured ranges 60V AC/DC

Measured ranges 300V AC/DC

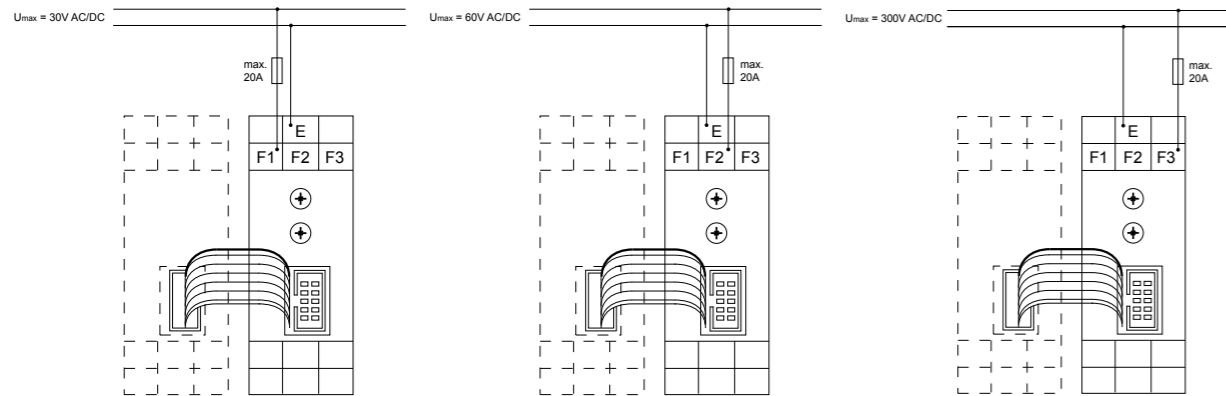

Width 22,5mm

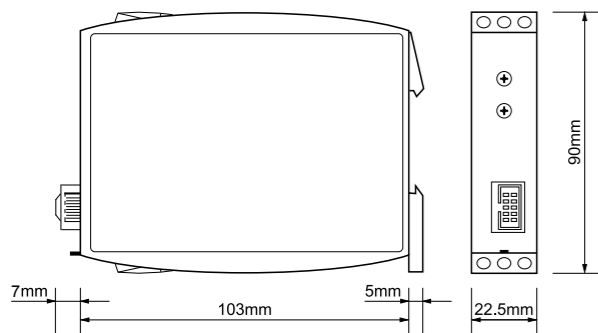

Connections

G2UI1 10V

Type

G2PI1 400V

G2PI480V

Art.No. (PQ1)

2500350

2500360

Art.No. (PQ10)

-

-

EAN13-Code

900866200490

-

Measured variable

Voltage AC Sinus (48 to 63Hz)

Voltage AC Sinus (48 to 63Hz)

Measured ranges

Phase voltages (U_1, U_2, U_3): 0 to 300V
 Average phase-phase voltage (U_{AVG}): 0 to 520V
 Asymmetry: 0% to 100%
 Phase sequence: 1 (clockwise rotation) • 0 (counter clockwise rotation)

Phase voltages (U_1, U_2, U_3): 0 to 360V
 Average phase-phase voltage (U_{AVG}): 0 to 624V
 Asymmetry: 0% to 100%
 Phase sequence: 1 (clockwise rotation) • 0 (counter clockwise rotation)

Controls

Address adjustment:
 Address range 1 to 99

Address adjustment:
 Address range 1 to 99

Indicators (LEDs)

U • Err • Com

U • Err • Com

Businterface

Standard bus (RS485)

Standard bus (RS485)

Overvoltage cat.

III (in accordance with IEC 60664-1)

III (in accordance with IEC 60664-1)

Rated surge voltage

6kV

6kV

Supply

24V DC from local interface

24V DC from local interface

Output

-

-

Width

22,5mm

22,5mm

Certificates

CE • GOST

CE • GOST

Mechanical Design

Self-extinguishing plastic housing, IP rating IP20 • Mounted on DIN-rail TS 35 in accordance with EN 60715 • Mounting position: any • Shockproof terminal connection according to VBG 4 (PZ1 required), IP rating IP20 • Tightening torque: max. 1Nm

Terminal capacity

1 x 0.5 to 2.5mm² with/without multicore cable end • 1 x 4mm² without multicore cable end • 2 x 0.5 to 1.5mm² with/without multicore cable end • 2 x 2.5mm² flexible without multicore cable end

Dimensions

Ambient conditions

Ambient temperature: -25 to +55°C (in accordance with IEC 60068-1); -25 to +40°C (in accordance with UL 508) • Storage temperature: -25 to +70°C • Transport temperature: -25 to +70°C • Relative humidity: 15% to 85% (in accordance with IEC 60721-3-3 class 3K3) • Absolute humidity: 1g to 25g H₂O/m³ (in accordance with IEC 60721-3-3 class 3K3) • Pollution degree: 2 (in accordance with IEC 60664-1) • Vibration resistance: 10 to 55Hz 0.35mm (in accordance with IEC 60068-2-6) • Shock resistance: 15g 11ms (in accordance with IEC 60068-2-27)

Accessories

-

WatchDog pro module for voltage measurement in 3-phase mains for 3- and 4-wire circuits. Monitoring of phase failure, phase sequence and asymmetry.



WatchDog pro

Monitoring voltage in 3-phase mains



- Measuring shunt voltage in 3-phase mains
- Common reference potential (GND)
- Reinforced isolation between the measuring circuit and the local interface
- Measured value transmission via standard bus
- Modular monitoring system
- Width 22,5mm
- Industrial design

G2PI1

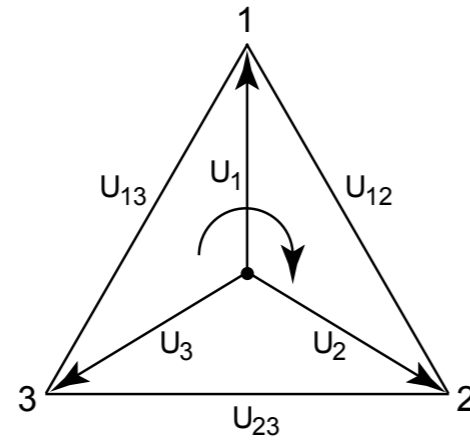
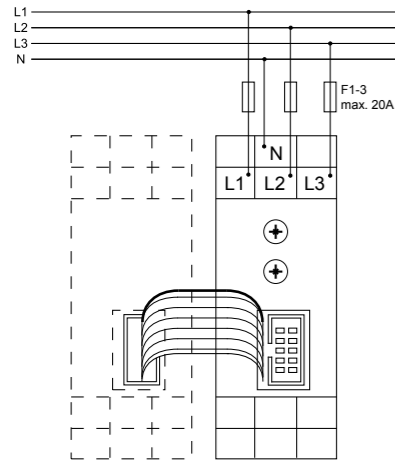

Width 22,5mm

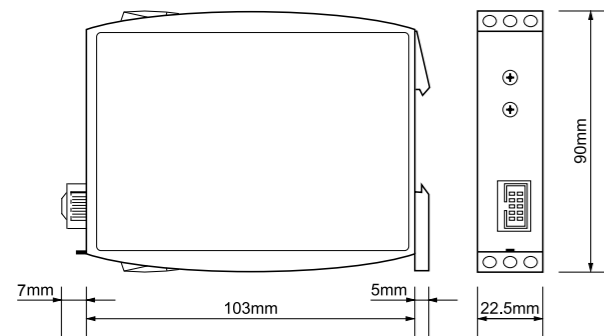

Functions

Connections

Type

G2YI3 60mV



| | |
|---------------------|--|
| Art.No. (PQ1) | 2500070 |
| Art.No. (PQ10) | - |
| EAN13-Code | 9008662006744 |
| Measured variable | Voltage DC or AC Sinus (48 bis 63Hz) |
| Measured ranges | 3 x 60mV AC/DC terminals E-F1(+) • E-F2(+) • E-F3(+) |
| Controls | Address adjustment: Address range 1 to 99 |
| Indicators (LEDs) | U • Err • Com |
| Businterface | Standard bus (RS485) |
| Overvoltage cat. | III (in accordance with IEC 60664-1) |
| Rated surge voltage | 6kV |
| Supply | 24V DC from local interface |
| Output | - |
| Width | 45mm |
| Certificates | CE • GOST |
| Mechanical Design | Self-extinguishing plastic housing, IP rating IP20 • Mounted on DIN-rail TS 35 in accordance with EN 60715 • Mounting position: any • Shockproof terminal connection according to VBG 4 (PZ1 required), IP rating IP20 • Tightening torque: max. 1Nm |
| Terminal capacity | 1 x 0.5 to 2.5mm ² with/without multicore cable end • 1 x 4mm ² without multicore cable end • 2 x 0.5 to 1.5mm ² with/without multicore cable end • 2 x 2.5mm ² flexible without multicore cable end |
| Ambient conditions | Ambient temperature: -25 to +55°C (in accordance with IEC 60068-1); -25 to +40°C (in accordance with UL 508) • Storage temperature: -25 to +70°C • Transport temperature: -25 to +70°C • Relative humidity: 15% to 85% (in accordance with IEC 60721-3-3 class 3K3) • Absolute humidity: 1g to 25g H ₂ O/m ³ (in accordance with IEC 60721-3-3 class 3K3) • Pollution degree: 2 (in accordance with IEC 60664-1) • Vibration resistance: 10 to 55Hz 0.35mm (in accordance with IEC 60068-2-6) • Shock resistance: 15g 11ms (in accordance with IEC 60068-2-27) |
| Accessories | - |

Dimensions

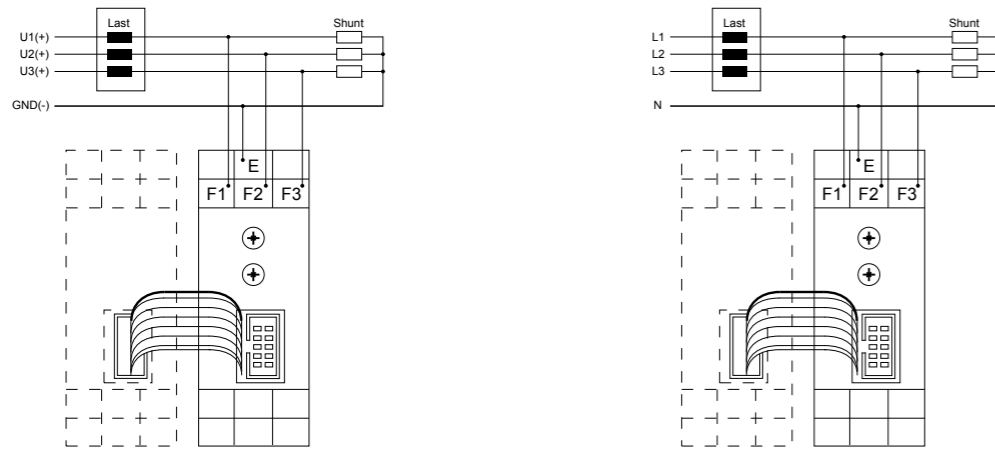

Width 22,5mm

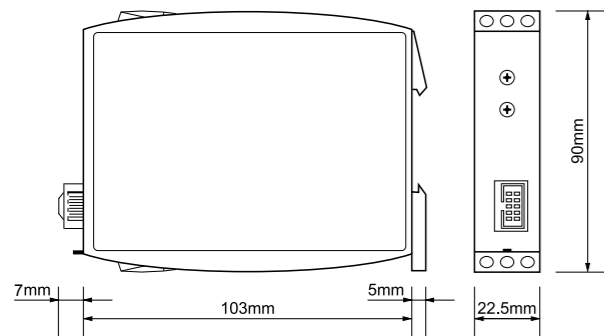

Functions



WatchDog pro

Current monitoring in 1-phase mains



- Current measurement in 1-phase mains
- Measuring range from 20mA and 5A (G2II1 5A)
- Measuring range from 100mA to 10A (G2II1 10A)
- Reinforced insulation of the measuring circuit
- Measured value transmitting via standard bus
- Modular monitoring system
- Width 22,5mm
- Industrial design

Connections

Type

G2II1 5A

G2II1 10A



| | | |
|---------------------|--|---|
| Art.No. (PQ1) | 2500251 | 2500250 |
| Art.No. (PQ10) | - | - |
| EAN13-Code | 900866200511 | 900866200491 |
| Measured variable | Current DC or AC Sinus (16,6 to 400Hz) | Current DC or AC Sinus (16,6 to 400Hz) |
| Measured ranges | 20mA AC/DC; terminals K-11(+) 1A AC/DC; terminals K-12(+) 5A AC/DC; terminals K-13(+) | 100mA AC/DC; terminals K-11(+) 1A AC/DC; terminals K-12(+) 10A AC/DC; terminals K-13(+) |
| Controls | Address adjustment: Address range 1 to 99 | Address adjustment: Address range 1 to 99 |
| Indicators (LEDs) | U • Err • Com | U • Err • Com |
| Businterface | Standard bus (RS485) | Standard bus (RS485) |
| Overvoltage cat. | III (in accordance with IEC 60664-1) | III (in accordance with IEC 60664-1) |
| Rated surge voltage | 6kV | 6kV |
| Supply | 24V DC from local interface | 24V DC from local interface |
| Output | - | - |
| Width | 22,5mm | 22,5mm |
| Certificates | CE • GOST | CE • GOST |
| Mechanical Design | Self-extinguishing plastic housing, IP rating IP20 • Mounted on DIN-rail TS 35 in accordance with EN 60715 • Mounting position: any • Shockproof terminal connection according to VBG 4 (PZ1 required), IP rating IP20 • Tightening torque: max. 1Nm | |
| Terminal capacity | 1 x 0.5 to 2.5mm ² with/without multicore cable end • 1 x 4mm ² without multicore cable end • 2 x 0.5 to 1.5mm ² with/without multicore cable end • 2 x 2.5mm ² flexible without multicore cable end | |
| Ambient conditions | Ambient temperature: -25 to +55°C (in accordance with IEC 60068-1); -25 to +40°C (in accordance with UL 508) • Storage temperature: -25 to +70°C • Transport temperature: -25 to +70°C • Relative humidity: 15% to 85% (in accordance with IEC 60721-3-3 class 3K3) • Absolute humidity: 1g to 25g H ₂ O/m ³ (in accordance with IEC 60721-3-3 class 3K3) • Pollution degree: 2 (in accordance with IEC 60664-1) • Vibration resistance: 10 to 55Hz 0.35mm (in accordance with IEC 60068-2-6) • Shock resistance: 15g 11ms (in accordance with IEC 60068-2-27) | |
| Accessories | - | |

Dimensions

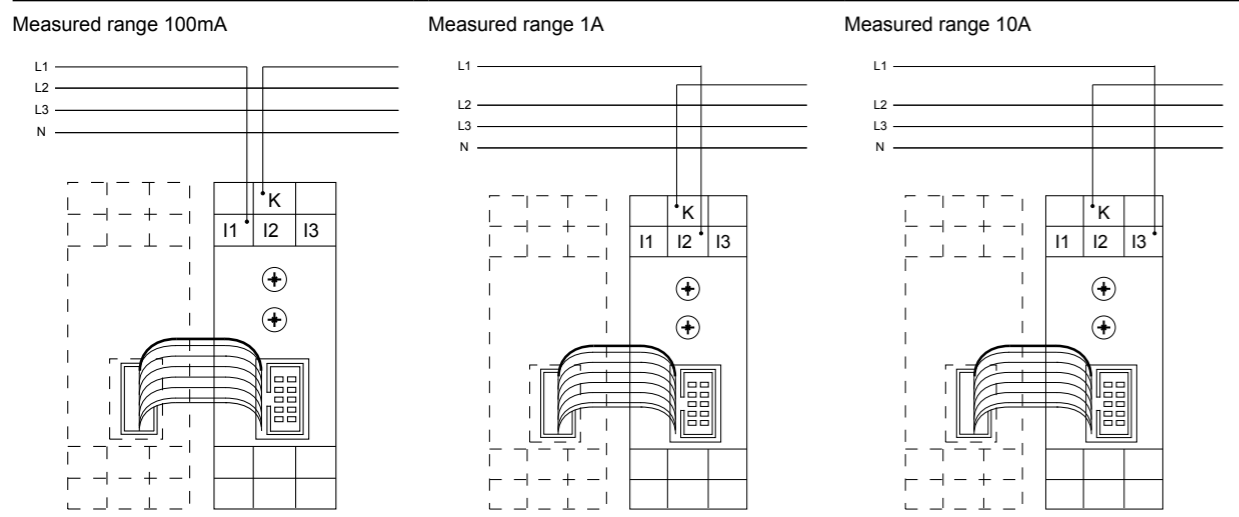
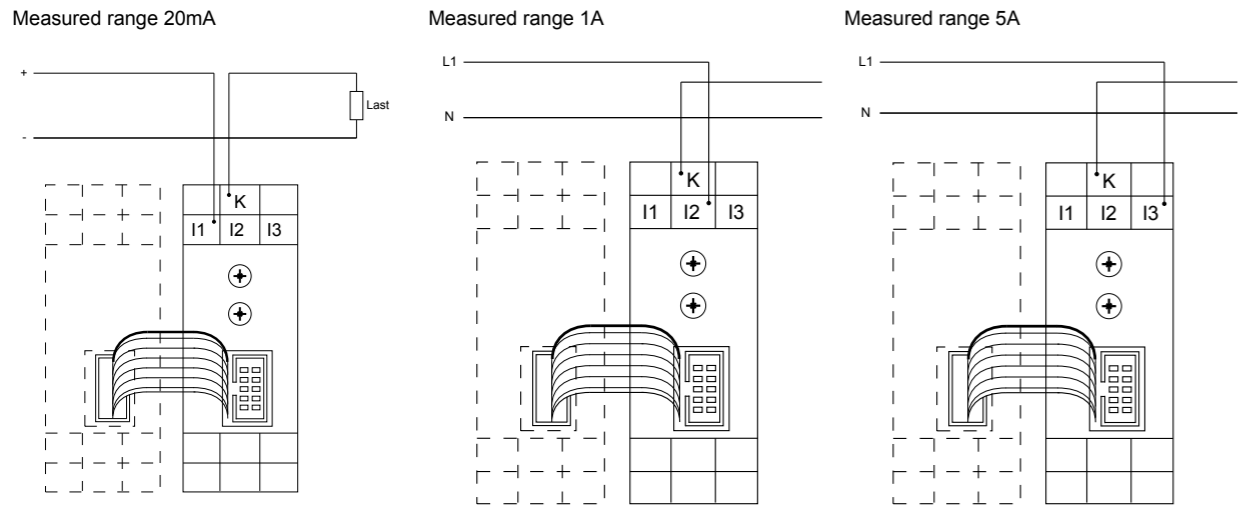

Width 22,5mm

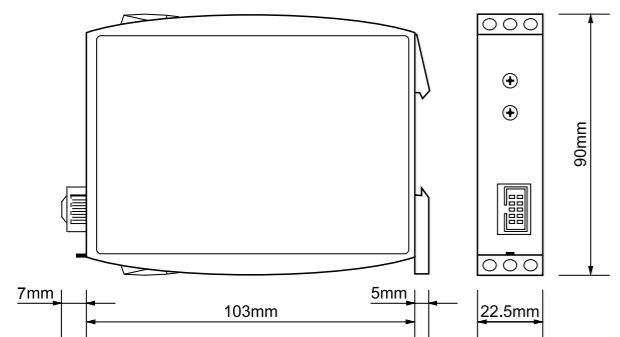

Functions



WatchDog pro
Current monitoring in 3-phase mains



- Current measurement in 3-phase mains
- Reinforced insulation of the measuring circuit
- Measured value transmitting via standard bus
- Modular monitoring system
- Width 22,5mm
- Industrial design

Connections

G2II1 5A

Type

G2JI1 5A

G2JI1 1A



Art.No. (PQ1)
Art.No. (PQ10)
EAN13-Code
Measured variable

Connections

G2II1 10A

Measured ranges
Controls
Indicators (LEDs)
Businterface
Overvoltage cat.
Rated surge voltage
Supply
Output
Width
Certificates
Mechanical Design
Terminal capacity

| | G2JI1 5A | G2JI1 1A |
|---------------------|--|--|
| Art.No. (PQ1) | 2500400 | 2500401 |
| Art.No. (PQ10) | - | - |
| EAN13-Code | 900866200526 | 9008662006331 |
| Measured variable | Current AC Sinus (48 to 63Hz) | Current AC Sinus (48 to 63Hz) |
| Measured ranges | 3 x 5AAC; terminals K-I1, K-I2, K-I3 | 3 x 1AAC; terminals K-I1, K-I2, K-I3 |
| Controls | Address adjustment: Address range 1 to 99 | Address adjustment: Address range 1 to 99 |
| Indicators (LEDs) | U • Err • Com | U • Err • Com |
| Businterface | Standard bus (RS485) | Standard bus (RS485) |
| Overvoltage cat. | III (in accordance with IEC 60664-1) | III (in accordance with IEC 60664-1) |
| Rated surge voltage | 6kV | 6kV |
| Supply | 24V DC from local interface | 24V DC from local interface |
| Output | - | - |
| Width | 22,5mm | 22,5mm |
| Certificates | CE • GOST | CE • GOST |
| Mechanical Design | Self-extinguishing plastic housing, IP rating IP20 • Mounted on DIN-rail TS 35 in accordance with EN 60715 • Mounting position: any • Shockproof terminal connection according to VBG 4 (PZ1 required), IP rating IP20 • Tightening torque: max. 1Nm | |
| Terminal capacity | 1 x 0.5 to 2.5mm ² with/without multicore cable end • 1 x 4mm ² without multicore cable end • 2 x 0.5 to 1.5mm ² with/without multicore cable end • 2 x 2.5mm ² flexible without multicore cable end | |
| Ambient conditions | Ambient temperature: -25 to +55°C (in accordance with IEC 60068-1); -25 to +40°C (in accordance with UL 508) • Storage temperature: -25 to +70°C • Transport temperature: -25 to +70°C • Relative humidity: 15% to 85% (in accordance with IEC 60721-3-3 class 3K3) • Absolute humidity: 1g to 25g H ₂ O/m ³ (in accordance with IEC 60721-3-3 class 3K3) • Pollution degree: 2 (in accordance with IEC 60664-1) • Vibration resistance: 10 to 55Hz 0.35mm (in accordance with IEC 60068-2-6) • Shock resistance: 15g 11ms (in accordance with IEC 60068-2-27) | |
| Accessories | - | |

Dimensions

G2JI1 5A without current transformer with common return

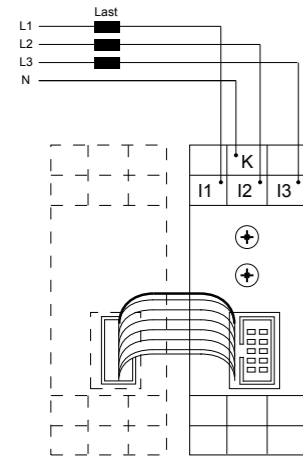

G2JI1 5A with current transformer with common return

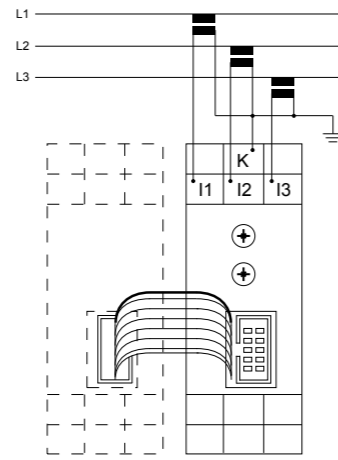

Width 22,5mm

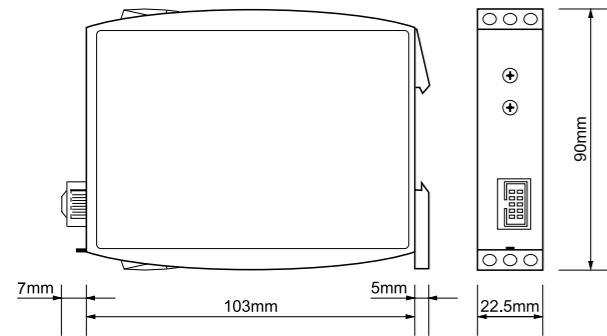

Functions



WatchDog pro

True power monitoring



- True power measurement of 1- or 3-phase loads
- Measurement ranges from 600W to 4,8kW
- Range adjustment via Central Unit
- Measured value transmitting via standard bus
- Modular monitoring system
- Width 22,5mm
- Industrial design

Connections

Type

G2BI1 400V12A



Art.No. (PQ1)

2500300

Art.No. (PQ10)

-

EAN13-Code

900866200489

Measured variable

True power of 1- or 3-phase loads
AC Sinus (10 to 400Hz)

Measured values

$P \cdot I_1$

True power ranges P_N

0,6kW • 1,2kW • 2,4kW • 4,8kW

Voltage ranges

1-phase loads: to 415VAC
3-phase loads: to 415/240VAC

Current ranges

Ranges 0,6 and 1,2kW: 6A
Ranges 2,4 and 4,8kW: 12A

Controls

Address adjustment:
Address range 1 to 99

Indicators (LEDs)

U • Err • Com

Businterface

Standard bus (RS485)

Overvoltage cat.

III (in accordance with IEC 60664-1)

Rated surge voltage

6kV

Supply

24V DC from local interface

Output

-

Width

22,5mm

Certificates

CE • GOST

Mechanical Design

Self-extinguishing plastic housing, IP rating IP20 • Mounted on DIN-rail TS 35 in accordance with EN 60715 • Mounting position: any • Shockproof terminal connection according to VBG 4 (PZ1 required), IP rating IP20 • Tightening torque: max. 1Nm

Terminal capacity

1 x 0.5 to 2.5mm² with/without multicore cable end • 1 x 4mm² without multicore cable end • 2 x 0.5 to 1.5mm² with/without multicore cable end • 2 x 2.5mm² flexible without multicore cable end

Ambient conditions

Ambient temperature: -25 to +55°C (in accordance with IEC 60068-1); -25 to +40°C (in accordance with UL 508) • Storage temperature: -25 to +70°C • Transport temperature: -25 to +70°C • Relative humidity: 15% to 85% (in accordance with IEC 60721-3-3 class 3K3) • Absolute humidity: 1g to 25g H₂O/m³ (in accordance with IEC 60721-3-3 class 3K3) • Pollution degree: 2 (in accordance with IEC 60664-1) • Vibration resistance: 10 to 55Hz 0.35mm (in accordance with IEC 60068-2-6) • Shock resistance: 15g 11ms (in accordance with IEC 60068-2-27)

Accessories

-

Dimensions

G2BI1 400V12A in 1-phase mains

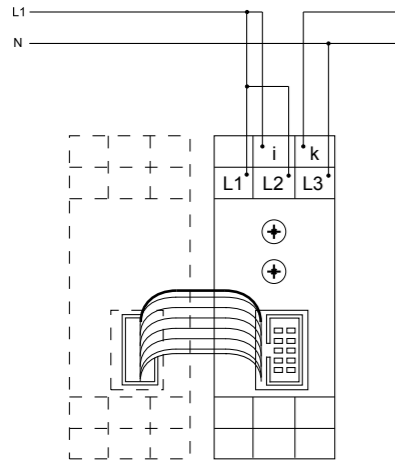

G2BI1 400V12A in 3-phase mains

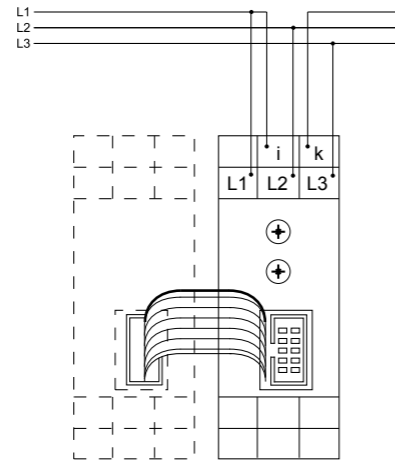

Phase voltage = $3 \times U_1$

G2BI1 400V12A in 3-phase mains with current transformer

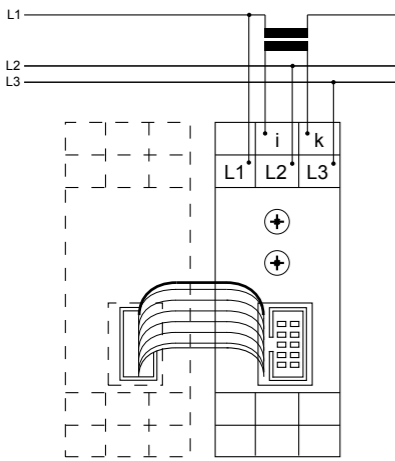

Width 22,5mm

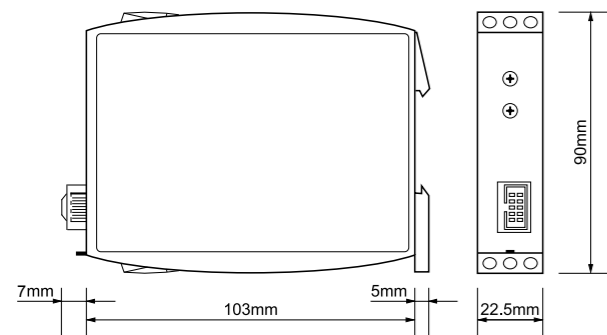

Functions



WatchDog pro

Power factor and power measurement



- Power factor and power measurement in 1- or 3-phase mains
- RMS measurement of one phase voltage and current of one phase
- Monitoring of motor / generator / capacitive / inductive loads
- 2 Measurement range 1,2kW and 4,8kW
- Measurement range adjustment via Central Unit
- Reinforced insulation of the measuring circuits
- Measured value transmitting via standard bus
- Width 22,5mm
- Industrial design

Connections

Type

G2CI1 400V12A



Art.No. (PQ1)

2500450

Art.No. (PQ10)

-

EAN13-Code

9008662005877

Measured variable

True power • Apparent power • Reactive power • Power factor • Phase voltage • Phase current
AC Sinus (10 to 400Hz)

Measured values

PF, P, S, Q, U_{eff} , I_{eff}

Measuring input current

6A • 12A

Measured range

1,2kW • 4,8kW

Voltage range

1-phase loads: to 415VAC
3-phase loads: to 415/240VAC

Controls

Address adjustment:
Address range 1 to 99

Indicators (LEDs)

U • Err • Com

Businterface

Standardbus (RS485)

Overvoltage cat.

III (in accordance with IEC 60664-1)

Rated surge voltage

6kV

Supply

24V DC from local interface

Output

-

Width

22,5mm

Certificates

CE • GOST

Mechanical Design

Self-extinguishing plastic housing, IP rating IP20 • Mounted on DIN-rail TS 35 in accordance with EN 60715 • Mounting position: any • Shockproof terminal connection according to VBG 4 (PZ1 required), IP rating IP20 • Tightening torque: max. 1Nm

Terminal capacity

1 x 0.5 to 2.5mm² with/without multicore cable end • 1 x 4mm² without multicore cable end • 2 x 0.5 to 1.5mm² with/without multicore cable end • 2 x 2.5mm² flexible without multicore cable end

Ambient conditions

Ambient temperature: -25 to +55°C (in accordance with IEC 60068-1); -25 to +40°C (in accordance with UL 508) • Storage temperature: -25 to +70°C • Transport temperature: -25 to +70°C • Relative humidity: 15% to 85% (in accordance with IEC 60721-3-3 class 3K3) • Absolute humidity: 1g to 25g H₂O/m³ (in accordance with IEC 60721-3-3 class 3K3) • Pollution degree: 2 (in accordance with IEC 60664-1) • Vibration resistance: 10 to 55Hz 0.35mm (in accordance with IEC 60068-2-6) • Shock resistance: 15g 11ms (in accordance with IEC 60068-2-27)

Accessories

-

Connections

Dimensions



WatchDog pro

Temperature monitoring



- 4 temperature measurement inputs with PT100 / PT1000 sensors
- Error indicators for short circuit and line break
- 2 and 3-wire connection
- Reinforced isolation between the input circuit and the local interface
- Measured value transmission via standard bus
- Modular monitoring system
- Width 22,5mm
- Industrial design

G2CI1 400V12A in 1-phase mains

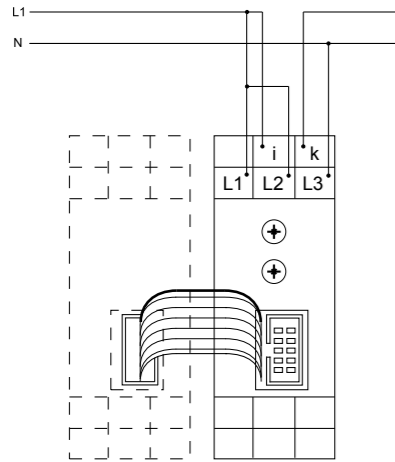

G2CI1 400V12A in 3-phase mains

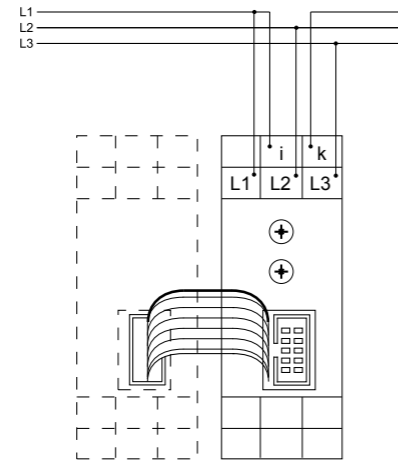

G2CI1 400V12A in 3-phase mains with current transformer

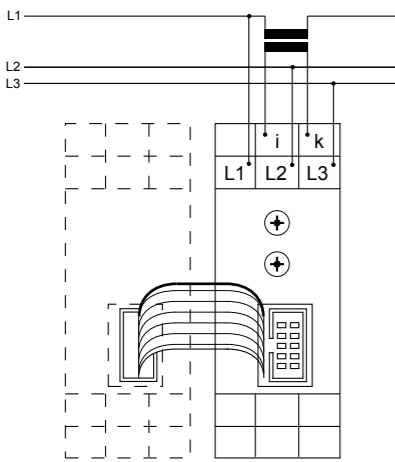

Width 22,5mm

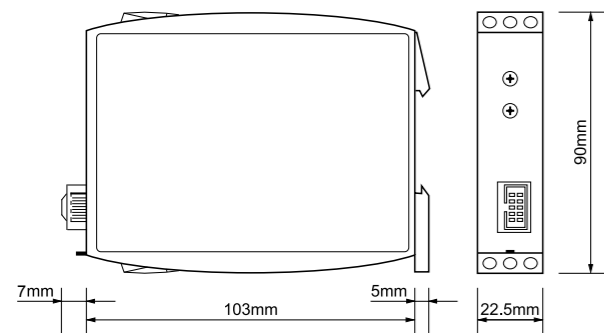

Functions

Connections

Connections

Dimensions

Type

G2TI4 PT



| | |
|---------------------|--|
| Art.No. (PQ1) | 2500160 |
| Art.No. (PQ10) | - |
| EAN13-Code | - |
| Measured variable | Temperature measurement PT100 or PT1000 (4-fold) 2-wire (with external bridge) and 3-wire connection |
| Measured ranges | -100°C to +300°C -200°C to +850°C |
| Controls | Address adjustment: Address range 1 to 99 |
| Indicators (LEDs) | U • Err • Com • 1PT • 2PT • 3PT • 4PT |
| Businterface | Standard bus (RS485) |
| Overvoltage cat. | III (in accordance with IEC 60664-1) |
| Rated surge voltage | 4kV |
| Supply | 24V DC from local interface |
| Output | - |
| Width | 22,5mm |
| Certificates | CE • GOST |
| Mechanical Design | Self-extinguishing plastic housing, IP rating IP20 • Mounted on DIN-rail TS 35 in accordance with EN 60715 • Mounting position: any • Shockproof terminal connection according to VBG 4 (PZ1 required), IP rating IP20 • Tightening torque: max. 1Nm |
| Terminal capacity | 1 x 0.5 to 2.5mm ² with/without multicore cable end • 1 x 4mm ² without multicore cable end • 2 x 0.5 to 1.5mm ² with/without multicore cable end • 2 x 2.5mm ² flexible without multicore cable end |
| Ambient conditions | Ambient temperature: -25 to +55°C (in accordance with IEC 60068-1); -25 to +40°C (in accordance with UL 508) • Storage temperature: -25 to +70°C • Transport temperature: -25 to +70°C • Relative humidity: 15% to 85% (in accordance with IEC 60721-3-3 class 3K3) • Absolute humidity: 1g to 25g H ₂ O/m ³ (in accordance with IEC 60721-3-3 class 3K3) • Pollution degree: 2 (in accordance with IEC 60664-1) • Vibration resistance: 10 to 55Hz 0.35mm (in accordance with IEC 60068-2-6) • Shock resistance: 15g 11ms (in accordance with IEC 60068-2-27) |
| Accessories | - |

3-wire measuring method

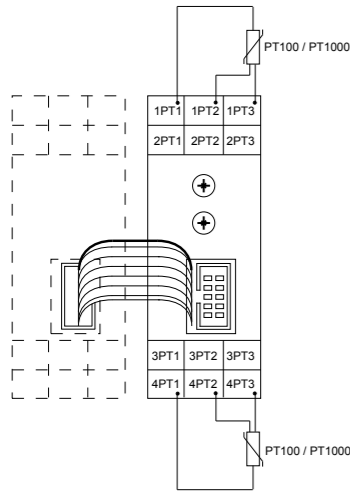

2-wire measuring method

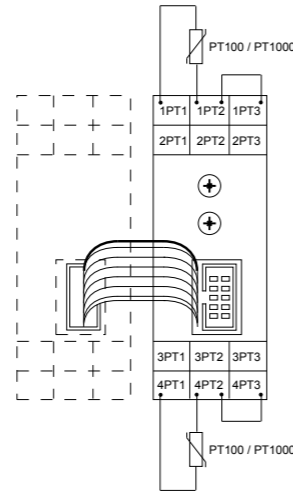

Width 22,5mm

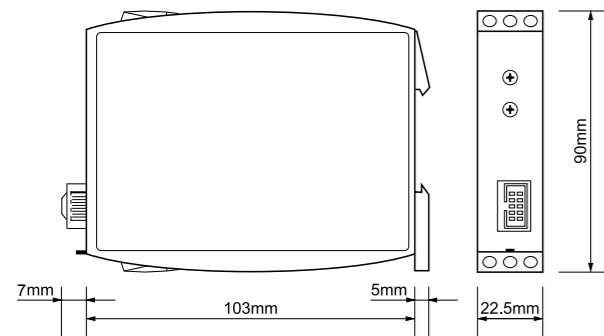

Functions



WatchDog pro

Digital Input



- 4 digital inputs with common ground (COM)
- Reinforced insulation of the input circuit
- Digital state transmitting via standard bus
- Modular monitoring system
- Width 22,5mm
- Industrial design

Connections

Type

G2DI4 24V

G2DI4 230V

G2DI4 SC



Art.No. (PQ1)

2500100

2500101

2500103

Art.No. (PQ10)

-

-

-

EAN13-Code

900866200330

900866200493

900866200492

Input circuit

Voltage AC/DC
AC Sinus (48 to 63Hz)

Voltage AC
AC Sinus (48 to 63Hz)

for potential free inputs
NPN sensors

Switch point
On / Off

DC: 9,3V / 5,3V
AC: 12,4V / 9,2V

AC: 153V / 53V

-

Controls

Address adjustment:
Address range 1 to 99

Address adjustment:
Address range 1 to 99

Address adjustment:
Address range 1 to 99

Indicators (LEDs)

U • Err • Com • DI1 • DI2 • DI3 • DI4

U • Err • Com • DI1 • DI2 • DI3 • DI4

U • Err • Com • DI1 • DI2 • DI3 • DI4

Businterface

Standard bus (RS485)

Standard bus (RS485)

Standard bus (RS485)

Overvoltage cat.

III (in accordance with IEC 60664-1)

III (in accordance with IEC 60664-1)

III (in accordance with IEC 60664-1)

Rated surge voltage

6kV

6kV

6kV

Supply

24V DC from local interface

24V DC from local interface

24V DC from local interface

Output

-

-

-

Width

22,5mm

22,5mm

22,5mm

Certificates

CE • GOST

CE • GOST

CE • GOST

Mechanical Design

Self-extinguishing plastic housing, IP rating IP20 • Mounted on DIN-rail TS 35 in accordance with EN 60715 • Mounting position: any • Shockproof terminal connection according to VBG 4 (PZ1 required), IP rating IP20 • Tightening torque: max. 1Nm

Terminal capacity

1 x 0.5 to 2.5mm² with/without multicore cable end • 1 x 4mm² without multicore cable end • 2 x 0.5 to 1.5mm² with/without multicore cable end • 2 x 2.5mm² flexible without multicore cable end

Ambient conditions

Ambient temperature: -25 to +55°C (in accordance with IEC 60068-1); -25 to +40°C (in accordance with UL 508) • Storage temperature: -25 to +70°C • Transport temperature: -25 to +70°C • Relative humidity: 15% to 85% (in accordance with IEC 60721-3-3 class 3K3) • Absolute humidity: 1g to 25g H₂O/m³ (in accordance with IEC 60721-3-3 class 3K3) • Pollution degree: 2 (in accordance with IEC 60664-1) • Vibration resistance: 10 to 55Hz 0.35mm (in accordance with IEC 60068-2-6) • Shock resistance: 15g 11ms (in accordance with IEC 60068-2-27)

Accessories

-

Dimensions

WatchDog pro module with 4 digital inputs.

G2DI4 24V

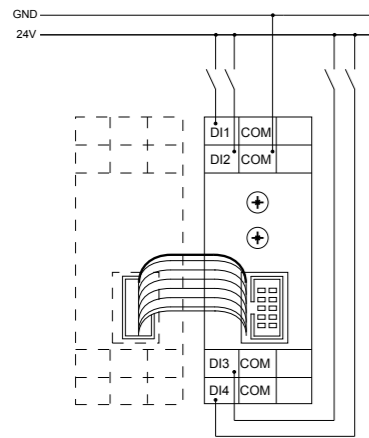

G2DI4 230V

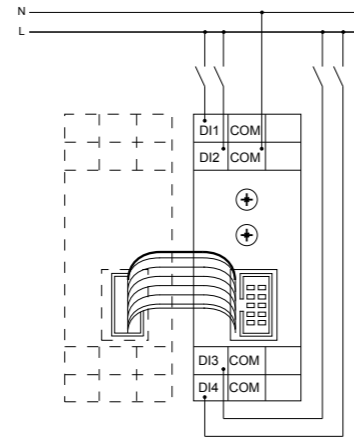

G2DI4 SC

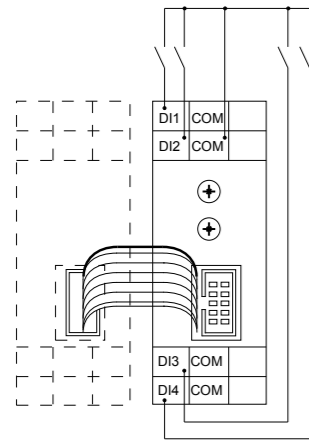

Width 22,5mm

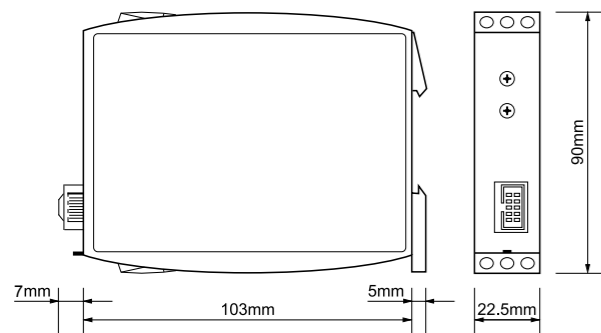

Functions



WatchDog pro

Overtemperature monitoring



- Temperature monitoring
- 4 PTC inputs
- Short circuit monitoring of the PTC inputs
- Reinforced insulation of the input circuit
- State transmission over Standard bus
- Modular monitoring system
- Width 22,5mm
- Industrial design

Connections

Type

G2DI4 PTCK



Art.No. (PQ1)

2500102

Art.No. (PQ10)

-

EAN13-Code

900866200494

Input circuit

PTC (Motor temperature)
max. 6 PTC sensors per input

Measured ranges

Initial resistance <1,5kΩ

Measuring voltage

max. 5V; ≤2,5V DC at R_{PTC} ≤4kΩ

Controls

Address adjustment:
Address range 1 to 99

Indicators (LEDs)

U • Err • Com • 1T • 2T • 3T • 4T

Response value

>3,6kΩ

Release value

<1,8kΩ

Short circuit monitoring

20Ω ± 10Ω

Businterface

Standard bus (RS485)

Overvoltage cat.

III (in accordance with IEC 60664-1)

Rated surge voltage

6kV

Supply

24V DC from local interface

Output

-

Width

22,5mm

Certificates

CE • GOST

Mechanical Design

Self-extinguishing plastic housing, IP rating IP20 • Mounted on DIN-rail TS 35 in accordance with EN 60715 • Mounting position: any • Shockproof terminal connection according to VBG 4 (PZ1 required), IP rating IP20 • Tightening torque: max. 1Nm

Terminal capacity

1 x 0.5 to 2.5mm² with/without multicore cable end • 1 x 4mm² without multicore cable end • 2 x 0.5 to 1.5mm² with/without multicore cable end • 2 x 2.5mm² flexible without multicore cable end

Ambient conditions

Ambient temperature: -25 to +55°C (in accordance with IEC 60068-1); -25 to +40°C (in accordance with UL 508) • Storage temperature: -25 to +70°C • Transport temperature: -25 to +70°C • Relative humidity: 15% to 85% (in accordance with IEC 60721-3-3 class 3K3) • Absolute humidity: 1g to 25g H₂O/m³ (in accordance with IEC 60721-3-3 class 3K3) • Pollution degree: 2 (in accordance with IEC 60664-1) • Vibration resistance: 10 to 55Hz 0.35mm (in accordance with IEC 60068-2-6) • Shock resistance: 15g 11ms (in accordance with IEC 60068-2-27)

Accessories

-

Connections

Dimensions

WatchDog pro Modul with 4 digital inputs for temperature monitoring with max. 6PTC.

G2DI4 PTCK

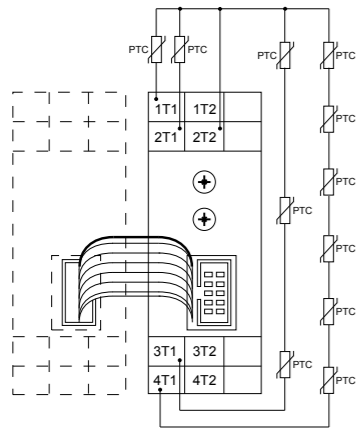

Width 22,5mm

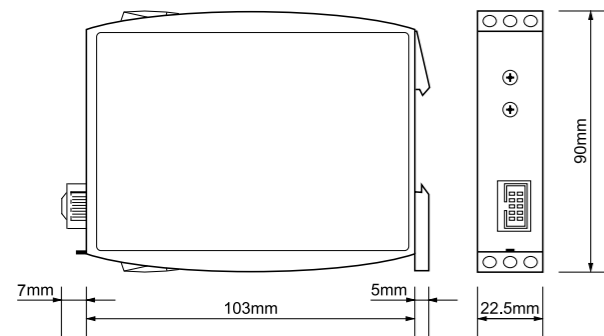

Functions



WatchDog pro

Digital input

WatchDog^{pro}



- 8 digital inputs with common reference potential
- Inputs are compatible with EN 61131-2 - digital input type 1
- Reinforced isolation between the input circuits and the local interface
- Status transmission via standard bus
- Modular monitoring system
- Width 22,5mm
- Industrial design

Connections

Type

G2DI8 24V



Art.No. (PQ1)

2500105

Art.No. (PQ10)

-

EAN13-Code

9008662006577

Input circuit

Voltage AC/DC
AC sinus (48 to 63Hz)

Controls

Address adjustment:
Address range 1 to 99

Indicators (LEDs)

U • Err • Com • DI1 • DI2 • DI3 • DI4 • DI5 • DI6 • DI7 • DI8

Businterface

Standard bus (RS485)

Overtoltage cat.

III (in accordance with IEC 60664-1)

Rated surge voltage

2,5kV

Supply

24V DC from local interface

Output

-

Width

22,5mm

Certificates

CE • GOST

Mechanical Design

Self-extinguishing plastic housing, IP rating IP20 • Mounted on DIN-rail TS 35 in accordance with EN 60715 • Mounting position: any • Shockproof terminal connection according to VBG 4 (PZ1 required), IP rating IP20 • Tightening torque: max. 1Nm

Terminal capacity

1 x 0.5 to 2.5mm² with/without multicore cable end • 1 x 4mm² without multicore cable end • 2 x 0.5 to 1.5mm² with/without multicore cable end • 2 x 2.5mm² flexible without multicore cable end

Ambient conditions

Ambient temperature: -25 to +55°C (in accordance with IEC 60068-1); -25 to +40°C (in accordance with UL 508) • Storage temperature: -25 to +70°C • Transport temperature: -25 to +70°C • Relative humidity: 15% to 85% (in accordance with IEC 60721-3-3 class 3K3) • Absolute humidity: 1g to 25g H₂O/m³ (in accordance with IEC 60721-3-3 class 3K3) • Pollution degree: 2 (in accordance with IEC 60664-1) • Vibration resistance: 10 to 55Hz 0.35mm (in accordance with IEC 60068-2-6) • Shock resistance: 15g 11ms (in accordance with IEC 60068-2-27)

Accessories

-

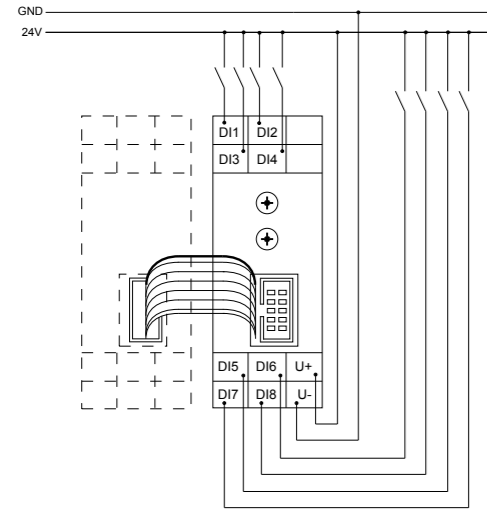

Width 22,5mm

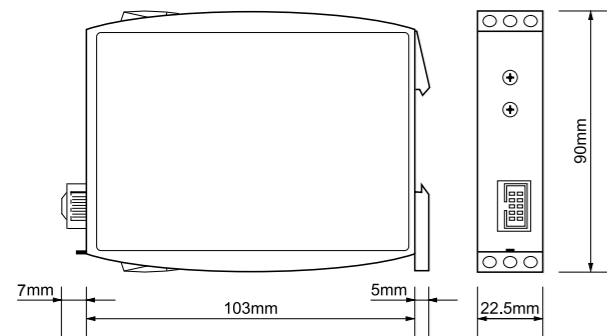

Functions



WatchDog pro

Digital outputs



- 4 potential free digital relay or semiconductor outputs
- Reinforced isolation between the outputs, relay version (G2DO4 R)
- Functional isolation between the outputs, semiconductor version (G2DO4 S)
- Short circuit protection of the outputs with error indicators (G2DO4 S)
- Reinforced isolation between the output circuits and the local interface
- Output state transmitting via standard bus
- Modular monitoring system
- Width 22,5mm
- Industrial design

Connections

Type

G2DO4 R

G2DO4 SP24VDC

G2DO4 SN24VDC



Art.No. (PQ1)

2500200

2500201

2500203

Art.No. (PQ10)

-

-

-

EAN13-Code

900866200525

9008662005655

9008662005662

Controls

Address adjustment:
Address range 1 to 99

Address adjustment:
Address range 1 to 99

Address adjustment:
Address range 1 to 99

Indicators (LEDs)

U • Err • Com • R1 • R2 • R3 • R4

U • Err • Com • O1 • O2 • O3 • O4

U • Err • Com • O1 • O2 • O3 • O4

Businterface

Standard bus (RS485)

Standard bus (RS485)

Standard bus (RS485)

Overvoltage cat.

III (in accordance with IEC 60664-1)

III (in accordance with IEC 60664-1)

III (in accordance with IEC 60664-1)

Rated surge voltage

6kV

2,5kV

2,5kV

Supply

24V DC from local interface

24V DC from local interface
24V DC for each output

24V DC from local interface
24V DC for each output

Output

4 potential free CO contacts

4 isolated PNP semiconductor outputs

4 isolated NPN semiconductor outputs

Switching capacity

1250VA (5A / 250V)

2A / 24V DC

2A / 24V DC

Width

22,5mm

22,5mm

22,5mm

Certificates

CE • GOST

CE • GOST

CE • GOST

Mechanical Design

Self-extinguishing plastic housing, IP rating IP20 • Mounted on DIN-rail TS 35 in accordance with EN 60715 • Mounting position: any • Shockproof terminal connection according to VBG 4 (PZ1 required), IP rating IP20 • Tightening torque: max. 1Nm

Terminal capacity

1 x 0.5 to 2.5mm² with/without multicore cable end • 1 x 4mm² without multicore cable end • 2 x 0.5 to 1.5mm² with/without multicore cable end • 2 x 2.5mm² flexible without multicore cable end

Ambient conditions

Ambient temperature: -25 to +55°C (in accordance with IEC 60068-1); -25 to +40°C (in accordance with UL 508) • Storage temperature: -25 to +70°C • Transport temperature: -25 to +70°C • Relative humidity: 15% to 85% (in accordance with IEC 60721-3-3 class 3K3) • Absolute humidity: 1g to 25g H₂O/m³ (in accordance with IEC 60721-3-3 class 3K3) • Pollution degree: 2 (in accordance with IEC 60664-1) • Vibration resistance: 10 to 55Hz 0.35mm (in accordance with IEC 60068-2-6) • Shock resistance: 15g 11ms (in accordance with IEC 60068-2-27)

Accessories

-

Dimensions

G2DO4 R

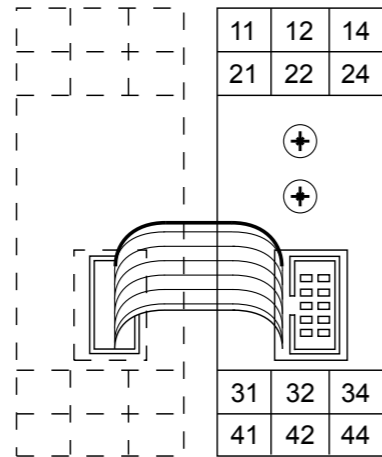
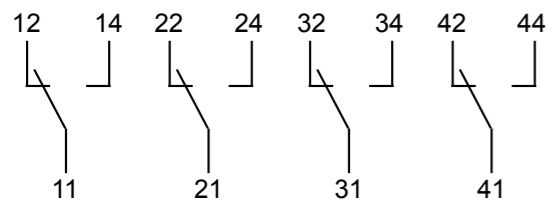

G2DO4 SP24VDC

G2DO4 SN24VDC

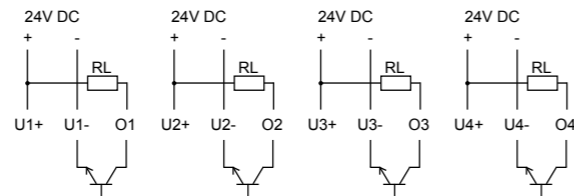
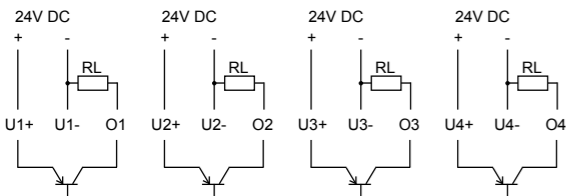

G2DO4 SP24VDC and G2DO4 SN24VDC

Width 22,5mm

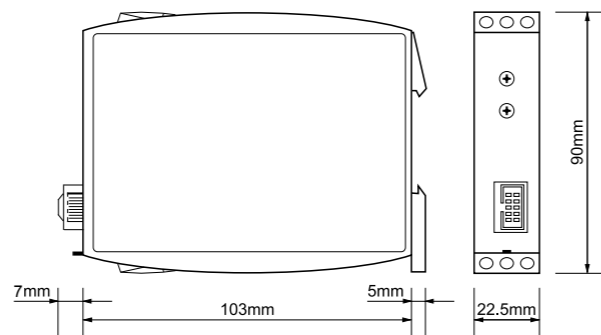
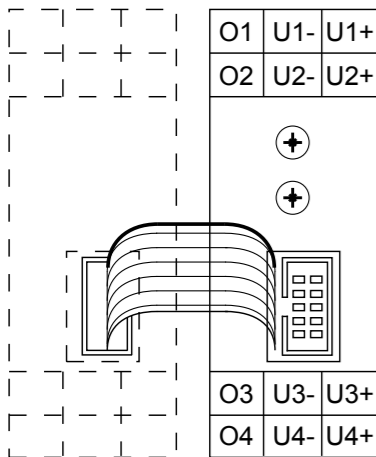

Functions



WatchDog pro

Digital output



- 8 separate semiconductor outputs
- Reinforced isolation between the output circuits and the local interface
- Common reference potential for all output circuits
- Short circuit protection of outputs with error display
- Output state transmitting via standard bus
- Modular monitoring system
- Width 22,5mm
- Industrial design

Connections

Type

G2DO8 SPC24VDC



Art.No. (PQ1)

2500205

Art.No. (PQ10)

-

EAN13-Code

9008662006584

Controls

Address adjustment:
Address range 1 to 99

Indicators (LEDs)

U • Err • Com • O1 • O2 • O3 • O4 • O4 • O5 • O6 • O7 • O8 • Oerr

Businterface

Standard bus (RS485)

Overvoltage cat.

III (in accordance with IEC 60664-1)

Rated surge voltage

2,5kV

Supply

24V DC from local interface

Output

8 isolated PNP semiconductor outputs

Width

22,5mm

Certificates

CE • GOST

Mechanical Design

Self-extinguishing plastic housing, IP rating IP20 • Mounted on DIN-rail TS 35 in accordance with EN 60715 • Mounting position: any • Shockproof terminal connection according to VBG 4 (PZ1 required), IP rating IP20 • Tightening torque: max. 1Nm

Terminal capacity

1 x 0.5 to 2.5mm² with/without multicore cable end • 1 x 4mm² without multicore cable end • 2 x 0.5 to 1.5mm² with/without multicore cable end • 2 x 2.5mm² flexible without multicore cable end

Ambient conditions

Ambient temperature: -25 to +55°C (in accordance with IEC 60068-1); -25 to +40°C (in accordance with UL 508) • Storage temperature: -25 to +70°C • Transport temperature: -25 to +70°C • Relative humidity: 15% to 85% (in accordance with IEC 60721-3-3 class 3K3) • Absolute humidity: 1g to 25g H₂O/m³ (in accordance with IEC 60721-3-3 class 3K3) • Pollution degree: 2 (in accordance with IEC 60664-1) • Vibration resistance: 10 to 55Hz 0.35mm (in accordance with IEC 60068-2-6) • Shock resistance: 15g 11ms (in accordance with IEC 60068-2-27)

Accessories

-

Connections

Dimensions

WatchDog pro module with 8 digital 24V PNP semi-conductor outputs.

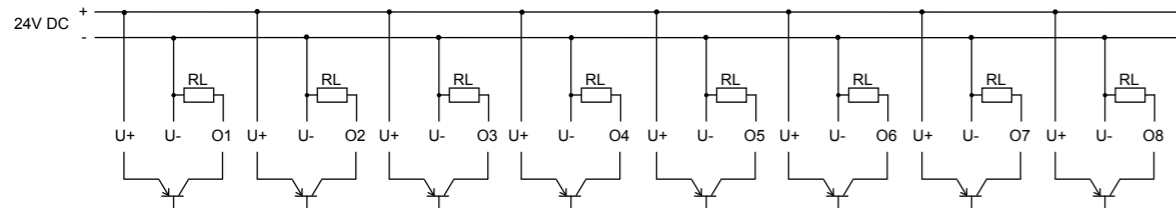
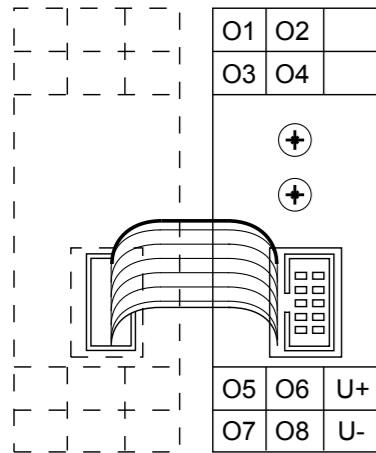

Width 22,5mm

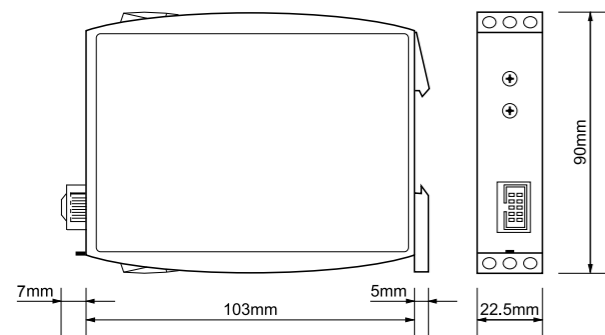

Functions



WatchDog pro

Standard signal In- and Output



- Analogue and digital input and output module for standard signals
- Common ground (GND)
- 2 voltage inputs (0-10V DC / 0-24V DC / NPN / PNP)
- 2 current inputs (0-20mA DC)
- 1 output (0-20mA DC / 0-10V DC / 12V / 24V)
- Reinforced insulation of the measuring circuits
- Measured value transmitting via standard bus
- Width 22,5mm
- Industrial design

Connections

Type

G2AM4 M



Art.No. (PQ1)
Art.No. (PQ10)
EAN13-Code
Measured variable

2500600

-

9008662005631

Standard signals

Input

0-20mA DC; terminals INI3 / INI4
0-10V / 0-24V / PNP / NPN; terminals INU1 / INU2

Output

0-20mA DC / 0-10V DC / 12V DC / 24V DC; terminals OUT-GND

Controls

Address adjustment:
Address range 1 to 99

Indicators (LEDs)

U • Err • Com

Businterface

Standard bus (RS485)

Overvoltage cat.

III (in accordance with IEC 60664-1)

Rated surge voltage

4kV

Supply

24V DC from local interface

Width

22,5mm

Certificates

CE • GOST

Mechanical Design

Self-extinguishing plastic housing, IP rating IP20 • Mounted on DIN-rail TS 35 in accordance with EN 60715 • Mounting position: any • Shockproof terminal connection according to VBG 4 (PZ1 required), IP rating IP20 • Tightening torque: max. 1Nm

Terminal capacity

1 x 0.5 to 2.5mm² with/without multicore cable end • 1 x 4mm² without multicore cable end • 2 x 0.5 to 1.5mm² with/without multicore cable end • 2 x 2.5mm² flexible without multicore cable end

Ambient conditions

Ambient temperature: -25 to +55°C (in accordance with IEC 60068-1); -25 to +40°C (in accordance with UL 508) • Storage temperature: -25 to +70°C • Transport temperature: -25 to +70°C • Relative humidity: 15% to 85% (in accordance with IEC 60721-3-3 class 3K3) • Absolute humidity: 1g to 25g H₂O/m³ (in accordance with IEC 60721-3-3 class 3K3) • Pollution degree: 2 (in accordance with IEC 60664-1) • Vibration resistance: 10 to 55Hz 0.35mm (in accordance with IEC 60068-2-6) • Shock resistance: 15g 11ms (in accordance with IEC 60068-2-27)

Accessories

-

Dimensions

WatchDog pro module with digital inputs and analog in- and outputs for standard signals with a common ground (GND).

Input signals: 0-10V DC, 0-24V DC, 0-20mA DC, NPN, PNP

Output signals: 0-10V DC, 0-20mA DC, 12V DC, 24V DC

G2AM4 M with voltage input signal

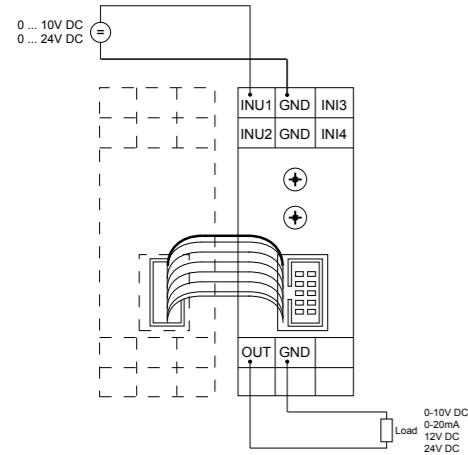

G2AM4 M with current input signal

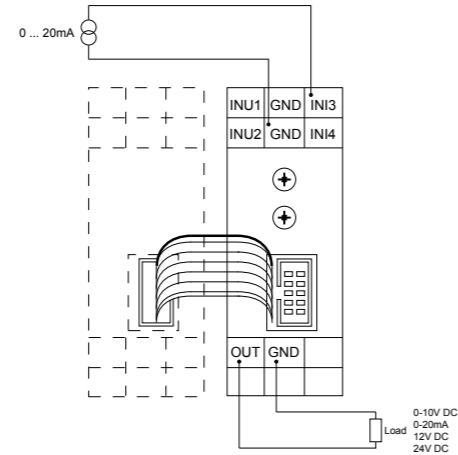

G2AM4 M with current and voltage input signal

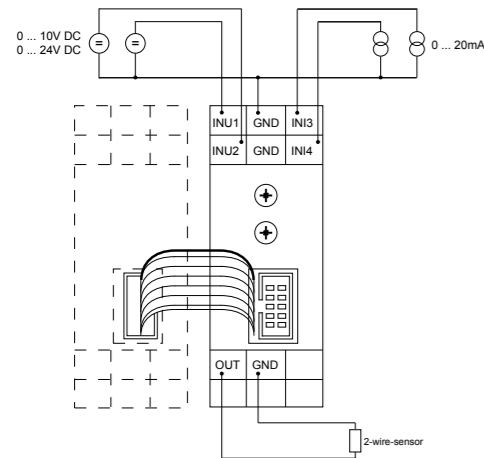

G2AM4 M with 2 PNP-sensors (supplied via G2AM4 M)

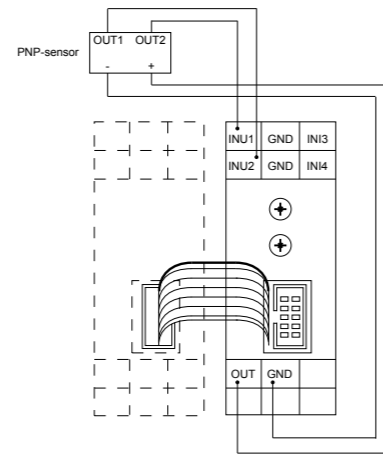

G2AM4 M with PNP-sensor and 4-20mA 3-wire-sensor

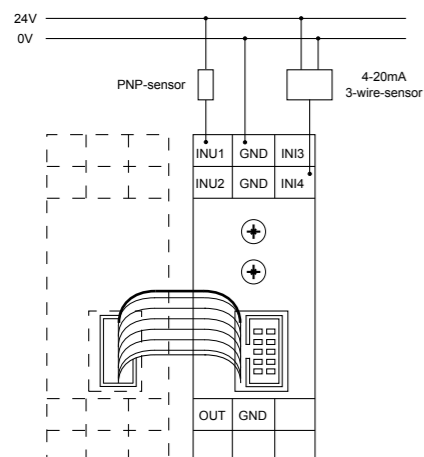

Width 22,5mm

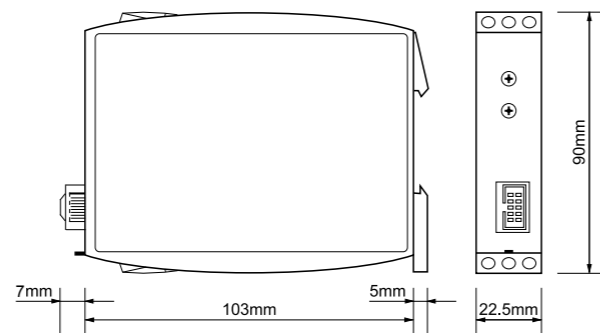

Functions



WatchDog pro

Fieldbus interface module



- WatchDog pro fieldbus connection to the process level
- Communication of I/O information to third party controls
- Data transmission via high speed bus
- Fieldbus interface modules are slaves on the fieldbus
- Modbus-RTU; Standard connection to touch panels
- Modbus-TCP
- Profibus-DPV1
- Width 22,5mm
- Industrial design

Connections

Type

G2FBC MB-RTU

G2FBC MB-TCP

G2FBC PB-DPV1



Art.No. (PQ1)

2500500

2500510

2500501

Art.No. (PQ10)

-

-

-

EAN13-Code

9008662005679

9008662005716

9008662005686

Fieldbus

Modbus-RTU

Modbus-TCP

Profibus-DPV1

Connector

Sub-D (female)

RJ45

Sub-D (female)

Controls

Baud rate
Address adjustment WatchDog pro:
Address range 1 to 99
Address adjustment Fieldbus:
Address range 1 to 247

Address adjustment WatchDog pro:
Address range 1 to 99

Address adjustment WatchDog pro:
Address range 1 to 99
Address adjustment Fieldbus:
Address range 1 to 126

Indicators (LEDs)

U • Err • Com

U • Err • Com

U • Err • Com

Businterface

High speed bus (RS485)

High speed bus (RS485)

High speed bus (RS485)

Galvanic separated

yes

yes

yes

Supply

24V DC from local interface

24V DC from local interface

24V DC from local interface

Width

22,5mm

22,5mm

22,5mm

Certificates

CE • GOST

CE • GOST

CE • GOST

Mechanical Design

Self-extinguishing plastic housing, IP rating IP20 • Mounted on DIN-rail TS 35 in accordance with EN 60715 • Mounting position: any • Shockproof terminal connection according to VBG 4 (PZ1 required), IP rating IP20 • Tightening torque: max. 1Nm

Terminal capacity

1 x 0.5 to 2.5mm² with/without multicore cable end • 1 x 4mm² without multicore cable end • 2 x 0.5 to 1.5mm² with/without multicore cable end • 2 x 2.5mm² flexible without multicore cable end

Ambient conditions

Ambient temperature: -25 to +55°C (in accordance with IEC 60068-1); -25 to +40°C (in accordance with UL 508) • Storage temperature: -25 to +70°C • Transport temperature: -25 to +70°C • Relative humidity: 15% to 85% (in accordance with IEC 60721-3-3 class 3K3) • Absolute humidity: 1g to 25g H₂O/m³ (in accordance with IEC 60721-3-3 class 3K3) • Pollution degree: 2 (in accordance with IEC 60664-1) • Vibration resistance: 10 to 55Hz 0.35mm (in accordance with IEC 60068-2-6) • Shock resistance: 15g 11ms (in accordance with IEC 60068-2-27)

Connections, Dimensions

Accessories
G2FBC MB-RTU

STANDARD CABLE HMI/WDP RS485 5M • CABLE HMI/WDP RS485 5M

Measured values, alarms and system information are sent from WatchDog pro to controllers or the process level with the field bus interface module. Via the fieldbus interface, control signals, nominal values or thresholds can be sent to WatchDog pro too. For the connection of WatchDog pro to touch panels with the Modbus-RTU interface module TELE provides cables as accessory.

G2FBC

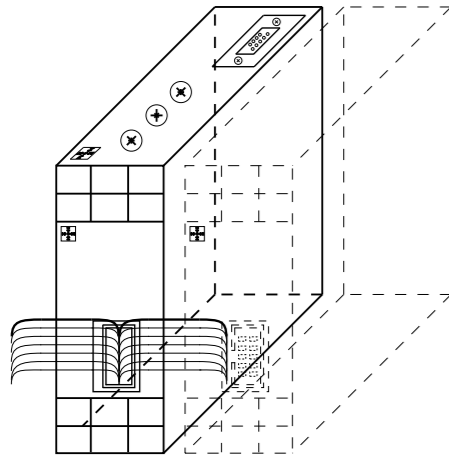

Width 22,5mm

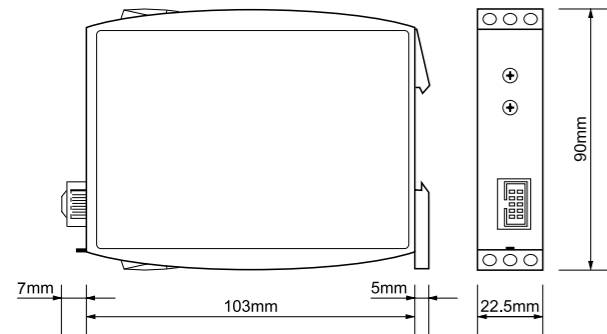

WatchDog pro

Fieldbus gateways



Functions

- Fieldbus connection between WatchDog pro modules and the process level
- No central unit, no monitoring functions
- Communication of measured values to third party controllers
- Gateways are slaves on the fieldbus
- Modbus-RTU
- Modbus-TCP
- Profibus-DPV1
- Width 22,5mm
- Industrial design

Connections

Type

G2WDGW2 MB-RTU

G2WDGW2 MB-TCP

G2WDGW2 PB-DVP1



Art.No. (PQ1)

2500550

2500560

2500551

Art.No. (PQ10)

-

-

-

EAN13-Code

9008662005693

9008662005747

9008662005709

Fieldbus

Modbus-RTU

Modbus-TCP

Profibus-DPV1

Connector

Sub-D (female)

RJ45

Sub-D (female)

Controls

Baud rate
Address adjustment Fieldbus:
Address range 1 to 247

-

Address adjustment Fieldbus:
Address range 1 to 126

Indicators (LEDs)

U • Err • Com

U • Err • Com

U • Err • Com

Businterface

Standard bus (RS485)

Standard bus (RS485)

Standard bus (RS485)

Galvanic separated

yes

yes

yes

Supply

24V DC

24V DC

24V DC

Width

22,5mm

22,5mm

22,5mm

Certificates

CE • GOST

CE • GOST

CE • GOST

Mechanical Design

Self-extinguishing plastic housing, IP rating IP20 • Mounted on DIN-rail TS 35 in accordance with EN 60715 • Mounting position: any • Shockproof terminal connection according to VBG 4 (PZ1 required), IP rating IP20 • Tightening torque: max. 1Nm

Terminal capacity

1 x 0.5 to 2.5mm² with/without multicore cable end • 1 x 4mm² without multicore cable end • 2 x 0.5 to 1.5mm² with/without multicore cable end • 2 x 2.5mm² flexible without multicore cable end

Ambient conditions

Ambient temperature: -25 to +55°C (in accordance with IEC 60068-1); -25 to +40°C (in accordance with UL 508) • Storage temperature: -25 to +70°C • Transport temperature: -25 to +70°C • Relative humidity: 15% to 85% (in accordance with IEC 60721-3-3 class 3K3) • Absolute humidity: 1g to 25g H₂O/m³ (in accordance with IEC 60721-3-3 class 3K3) • Pollution degree: 2 (in accordance with IEC 60664-1) • Vibration resistance: 10 to 55Hz 0.35mm (in accordance with IEC 60068-2-6) • Shock resistance: 15g 11ms (in accordance with IEC 60068-2-27)

Accessories

-

Dimensions

Measured values from the WatchDog pro modules are put directly to the used fieldbus. The output modules are controlled with the fieldbus. Monitoring and controlling tasks have to be managed with external controllers or in the process level.

Functions



WatchDog pro

Remote bus coupler



- Distributed WatchDog pro system enlargement
- System extension up to 99 modules
- Up to 24 modules per remote bus coupler
- Up to 40 remote bus couplers per Central unit
- Bus length is limited with 500 meters (remote bus cable)
- Width 22,5mm
- Industrial design

G2WDGW2

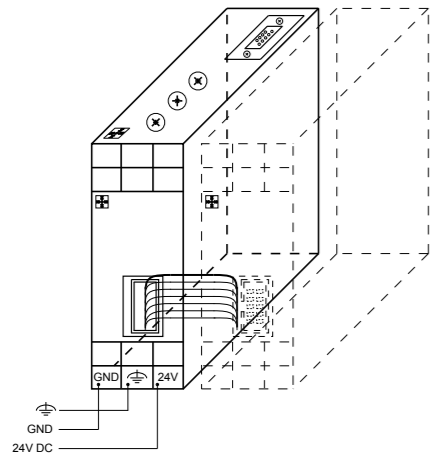

Connections

Width 22,5mm

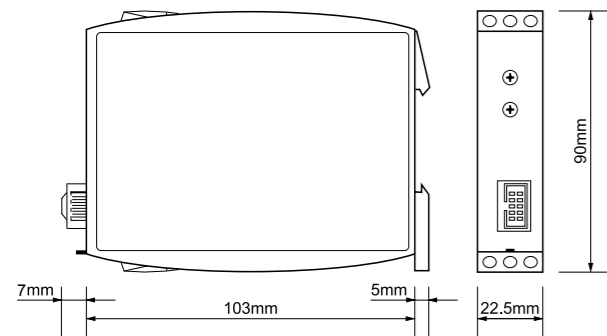

Dimensions

Type

G2RBC



| | |
|--------------------|--|
| Art.No. (PQ1) | 2500700 |
| Art.No. (PQ10) | - |
| EAN13-Code | 90086620059 |
| Interface | WatchDog pro remote bus |
| Terminals | Shld • RBA • RBB |
| Controls | R _{TER} (terminator) |
| Indicators (LEDs) | U • R _{TER} |
| Businterface | WatchDog pro remote bus (RS485) |
| Galvanic separated | yes |
| Supply | 24V DC |
| Width | 22,5mm |
| Certificates | CE • GOST |
| Mechanical Design | Self-extinguishing plastic housing, IP rating IP20 • Mounted on DIN-rail TS 35 in accordance with EN 60715 • Mounting position: any • Shockproof terminal connection according to VBG 4 (PZ1 required), IP rating IP20 • Tightening torque: max. 1Nm |
| Terminal capacity | 1 x 0.5 to 2.5mm ² with/without multicore cable end • 1 x 4mm ² without multicore cable end • 2 x 0.5 to 1.5mm ² with/without multicore cable end • 2 x 2.5mm ² flexible without multicore cable end |
| Ambient conditions | Ambient temperature: -25 to +55°C (in accordance with IEC 60068-1); -25 to +40°C (in accordance with UL 508) • Storage temperature: -25 to +70°C • Transport temperature: -25 to +70°C • Relative humidity: 15% to 85% (in accordance with IEC 60721-3-3 class 3K3) • Absolute humidity: 1g to 25g H ₂ O/m ³ (in accordance with IEC 60721-3-3 class 3K3) • Pollution degree: 2 (in accordance with IEC 60664-1) • Vibration resistance: 10 to 55Hz 0.35mm (in accordance with IEC 60068-2-6) • Shock resistance: 15g 11ms (in accordance with IEC 60068-2-27) |
| Accessories | - |

The remote bus coupler enables distributed WatchDog pro system enlargement. The central unit as well as the remote bus coupler are able to supply 24 modules. The number of modules in one WatchDog pro system (Central unit and remote bus coupler) is limited by 99.

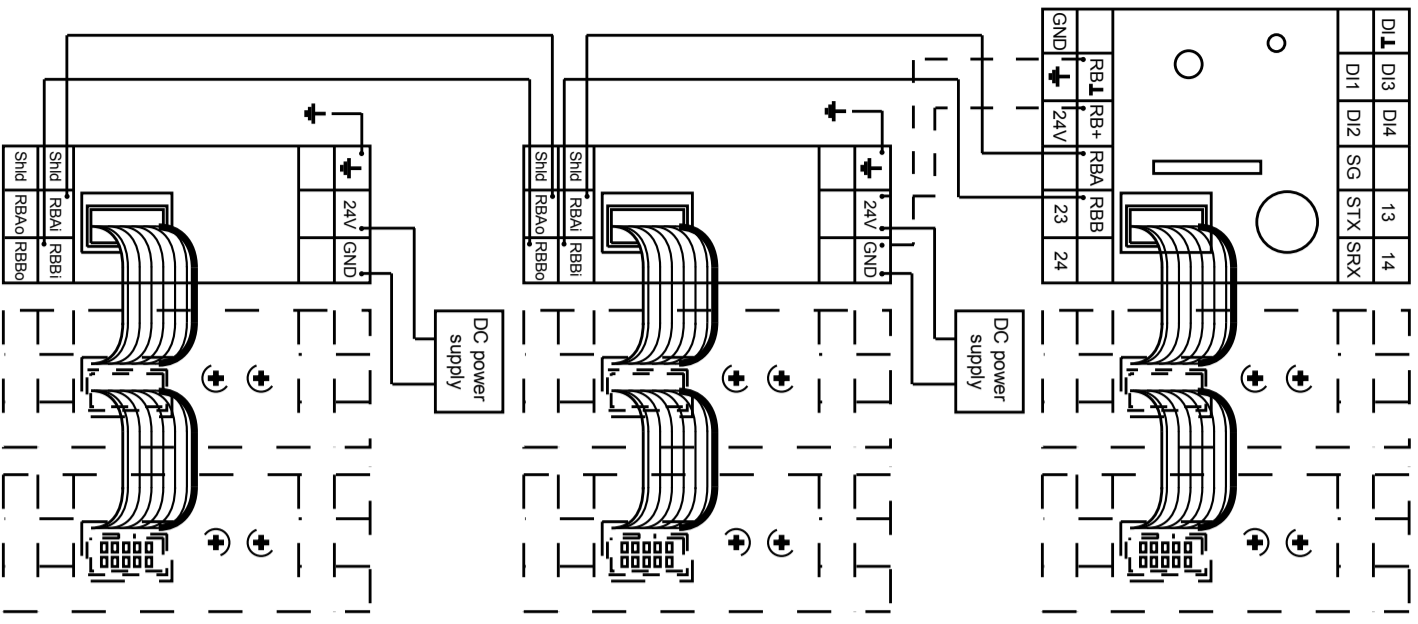

Functions

Connections

| Type | GP4105W1D | AGP3200-T1-D24 | AST3201-AT-D24 | AGP3300-S1-D24 | AGP3301-S1-D24 | AGP3302-B1-D24 | AGP3400-T1-D24 | AGP3400-S1-D24 | AGP3500-T1-D24 |
|------|-----------|----------------|----------------|----------------|----------------|----------------|----------------|----------------|----------------|
|------|-----------|----------------|----------------|----------------|----------------|----------------|----------------|----------------|----------------|



| Technical Data: | | GP4105W1D | AGP3200-T1-D24 | AST3201-AT-D24 | AGP3300-S1-D24 | AGP3301-S1-D24 | AGP3302-B1-D24 | AGP3400-T1-D24 | AGP3400-S1-D24 | AGP3500-T1-D24 |
|--------------------------|------------------|-------------------------|----------------|----------------|----------------|----------------|----------------|----------------|----------------|----------------|
| Display size | Inch/ mm | 3,4/ 86,4 | 3,8/ 96,5 | 3,8/ 96,5 | 5,7/ 145 | 5,7/ 145 | 5,7/ 145 | 7,5/ 188 | 7,5/ 188 | 10,4/ 264 |
| Dimensions | B | 16,5 | 130 | 130 | 167,5 | 167,5 | 167,5 | 215 | 215 | 270,5 |
| | H | 77,5 | 104 | 104 | 135 | 135 | 135 | 170 | 170 | 212,5 |
| | T | 28 | 41 | 41 | 59,5 | 59,5 | 59,5 | 60 | 60 | 57 |
| Display-Type | | STN white; pink; red | TFT Colour | Amber or red | STN Colour | STN Colour | Blue Mode | TFT Colour | STN Colour | TFT Colour |
| Resolution [Pixel]: | 200 x 80 | ■ | | | | | | | | |
| | 320 x 240 (QVGA) | | ■ | ■ | ■ | ■ | ■ | | | |
| | 640 x 480 (VGA) | | | | | | | ■ | ■ | ■ |
| Colour | | | | | | | | | | |
| 8 levels of grayscale | | | | ■ | | | | | | |
| 16 levels of grayscale | | ■ | | | | | | | | |
| 16 levels of bluescale | | | | | | | ■ | | | |
| 256 Colour | | | ■ | | | | | | | |
| 4.096 Colour | | | | | ■ | ■ | | | ■ | |
| 65.536 Colour | | | | | | | | ■ | | ■ |
| Interface | | | | | | | | | | |
| Seriell SIO (RS-232C) | | ■ | ■ | ■ | ■ | ■ | ■ | ■ | ■ | ■ |
| Seriell SIO (RS-422/485) | | | ■ | ■ | ■ | ■ | ■ | ■ | ■ | ■ |
| USB | | ■ | ■ | ■ | ■ | ■ | ■ | ■ | ■ | ■ |
| CF-Cards | | | | | ■ | ■ | ■ | ■ | ■ | ■ |
| Expansion bus | | | | | ■ | ■ | ■ | ■ | ■ | ■ |
| Ethernet | | | ■ | | ■ | | | ■ | ■ | ■ |
| AUX/ Sound-Out | | | | | | | | ■ | ■ | ■ |
| Articelnumber | | 542103 | 540113 | 540010 | 540124 | 540123 | 540120 | 540132 | 540131 | 540152 |
| Type | | GP4105W1D | AGP3200-T1-D24 | AST3201-AT-D24 | AGP3300-S1-D24 | AGP3301-S1-D24 | AGP3302-B1-D24 | AGP3400-T1-D24 | AGP3400-S1-D24 | AGP3500-T1-D24 |



Energymanagement Series ECO III

Maximum load controller



ECO - The system

The new EcoSyst range in conjunction with the EcoGate expansion modules now makes it possible to implement effective energy management cost effectively even in large sites. For the first time, these devices make it possible to record, assess and control the current consumption of a monitored building centrally while performing the switching activity this requires on a decentralized basis directly in the individual subdistributions. To achieve this, each EcoSyst maximum peak load monitor can communicate with up to 7 EcoGate expansion modules through the standard protocol running over RS 485. In this way, up to 64 different consumers or consumer groups can be managed and switched on and off.

| Type | ECO8 III SYS | ECO8 III GATE |
|--------------------------|--|---|
| Art.No. (PQ1) | 620160 | 620161 |
| EAN13-Code | 900866200370 | 900866200371 |
| Functions | Maximum load controller for allocation of power peaks. Trend computation and limitation of peak power. Variable cycle durations after specification of the EVU adjustable or limitation of the instantaneous values. Amplification up to 64 consumer groups by dint of ECO-GATE amplification modules. | Output extension unit to ECO-SYS. The base device can be extended by 8 signal paths. Maximum 7 ECO GATE's per ECO-SYS are lockable over decentral two-wire bus. Connection facility for sub counter. Control contacts to influence the control mode of individual circuits. |
| Additional functions | integrated digital time switch for each channel • datalogger | integrated digital time switch for each channel |
| Controls | 4 button prgramming | 4 button prgramming |
| Indicators (LEDs) | Display • 8 LEDs for output status • Failure • Power | Display • 8 LEDs for output status • Failure • Power |
| Time ranges | min. turn-on time: 0s to 19min 59sec min. turn-off time: 1s to 19min 59sec max. turn-off time: 1s to 19min 59sec | min. turn-on time: 1s to 19min 59sec min. turn-off time: 1s to 19min 59sec max. turn-off time: 1s to 19min 59sec |
| Priority of outputs | 64 levels of priority selectable | 64 levels of priority selectable |
| Control input PWR | Function: power pulse from energy meter Connected: galvanic separated; terminals 28, 29 Typ: S0 (DIN 43864); 12,5mA DC / 15V DC (max. 50Hz) | Function: Connection from sub energy meter Connected: galvanic separated; terminals 28, 29 Typ: S0 (DIN 43864); 12,5mA DC / 15V DC (max. 50Hz) |
| Additional control input | Control input SYNC: pulse for synchronisation from the grid operator Connected: galvanic separated; terminals 30, 31 Typ: S0 (DIN 43864); 12,5mA DC / 15V DC Control input TAR: changing tariff input from the grid operator Connected: galvanic separated; terminals 32, 33 Typ: S0 (DIN 43864); 12,5mA DC / 15V DC Control input CLK: synchronisation of the clock (optional) Connected: galvanic separated; terminals 34, 35 Typ: current loop; 6,25mA DC / 15V DC Control input MOFF: turn off all loads immediately (optional) Connected: galvanic separated; terminals 36, 37 Typ: current loop; 6,25mA DC / 15V DC | Control input IN1 to IN5 control outputs 1 to 5 (according to program settings) Connected: galvanic separated; terminals 30 to 39 Typ: current loop; 6,25mA DC / 15V DC |
| Supply | 110 to 240V AC or 110 to 300V DC; terminals A1-A2 | 110 to 240V AC or 110 to 300V DC; terminals A1-A2 |
| Output | 8 potential free NO contact 230V AC, 3A (control load groups) 1 potential free CO contact 230V AC, 3A (failure) | 8 potential free NO contact 230V AC, 3A (control load groups) 1 potential free CO contact 230V AC, 3A (failure) |
| Width | 157,5mm | 157,5mm |
| Certificates | CE | CE |
| Mechanical design | Self-extinguishing plastic housing, IP rating IP40 • Mounted on DIN-Rail TS 35 in accordance with EN 60715 • Mounting position: any • Shockproof terminal connection according to VBG 4, IP rating IP20 • recommended/max wire stripping for terminal connection: 6mm/9mm | |
| Terminal capacity | 1 x 0,5 to 2,5mm ² flexible without multicore cable end • 2 x 0,5 to 1,5mm ² flexible without multicore cable end • 1 x 1 to 2,5mm ² starr/with multicore cable end | |
| Ambient conditions | Ambient temperature: 0 to 50°C (in accordance with IEC 60068-1) • Storage temperature: -25 to +70°C • Transport temperature: -25 to +70°C • relative humidity: 15% to 85% (in accordance with IEC 60721-3-3 class 3K3) • Pollution degree: 2, if built in 3 (in accordance with IEC 60664-1) | |
| Accessories | ECO III COM (Art.Nr. 620170) for PC-Communication, Datalogger reading and parameter settings via RS232 or USB-Port Content: converter RS232/RS485 and USB/RS232; adapter 9pin/25pin; datacable 9pin (1m); Software on CD ROM | |

ECO - How it works

In most residential as well as in commercial buildings, the operation of some devices might be disabled a few minutes without inconvenience of comfort and functionality. Eco takes advantage of this by disconnecting „loads“ such as heating of rooms or hot water provision for short periods. As soon as the consumer system being monitored is again drawing less power, users that had previously been disconnected are progressively reconnected and can continue operating.

The overall result is a significantly more consistent power uptake by the entire monitored consuming system – the plant's power requirement is reduced.

Control inputs

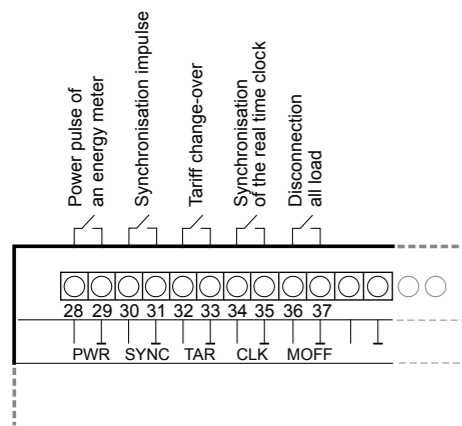

Connections

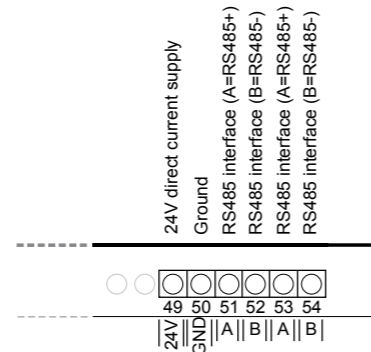

Outputs

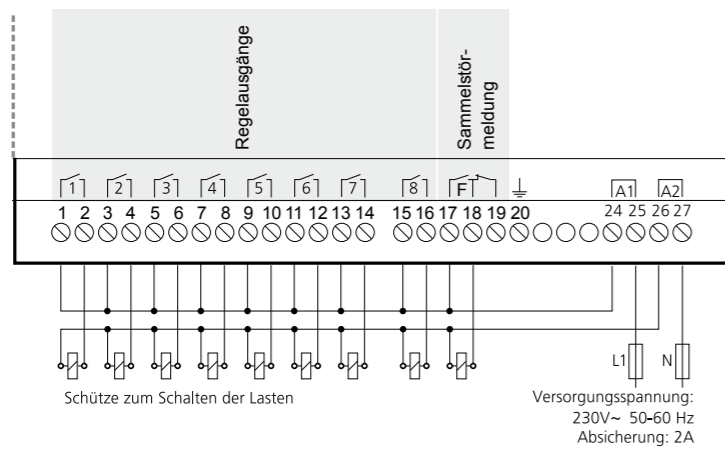

Width 157,5mm

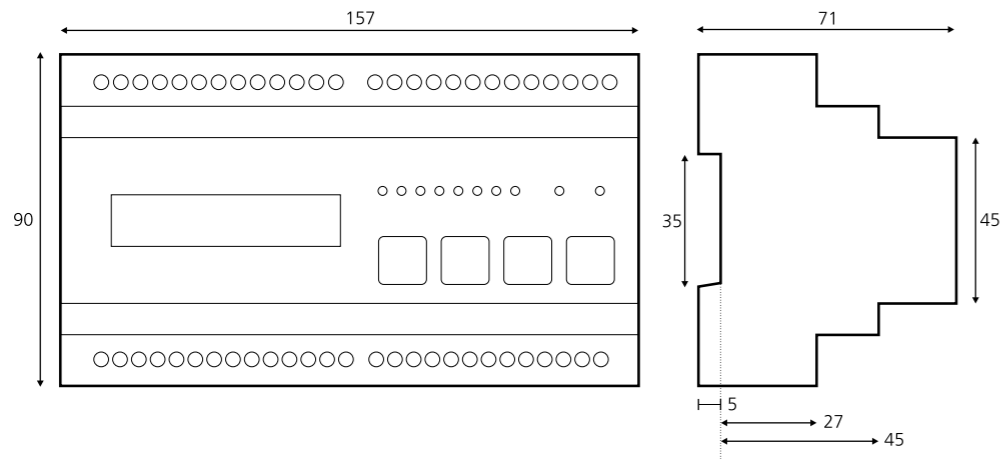

Functions



Sequence processor Series STEP-T8

State machine

- Sequence processor with 4x20 programm steps
- Function of control inputs programmable
- 7 operation modes
- Remanent latch function (selectable)
- 8 NO contact
- 1 CO contact
- Width 157,5mm
- Installation design

Connections

Type

STEP-T8 110VAC

STEP-T8 230VAC

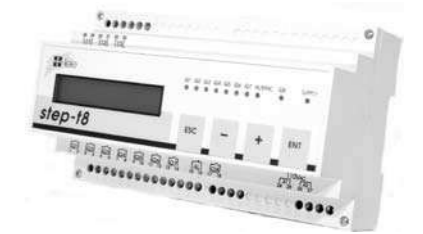
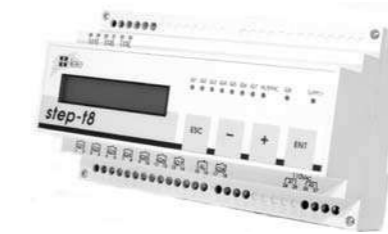

Art.No. (PQ1)

454002

454001

Art.No. (PQ10)

-

-

EAN13-Code

900866200365

900866200364

Controls

4 button programming

4 button programming

Indicators (LEDs)

Display • 8 LEDs for output status • AL/SYNC • Power

Display • 8 LEDs for output status • AL/SYNC • Power

Functions

Sequence processor with 4x20 programm steps
7 operation modes selectable:

Sequence processor with 4x20 programm steps
7 operation modes selectable:

MODE 0 (standard - factory default) • **MODE 1** (power failure detection)
• **MODE 2** (start requirement) • **MODE 3** (power failure detection and start requirement) • **MODE 4** (standard with extended Stop-function) • **MODE 5** (power failure detection with extended Stop-function) • **MODE 6** (start requirement with extended Stop-function) • **MODE 7** (power failure detection and start requirement with extended Stop-function)

MODE 0 (standard - factory default) • **MODE 1** (power failure detection)
• **MODE 2** (start requirement) • **MODE 3** (power failure detection and start requirement) • **MODE 4** (standard with extended Stop-function) • **MODE 5** (power failure detection with extended Stop-function) • **MODE 6** (start requirement with extended Stop-function) • **MODE 7** (power failure detection and start requirement with extended Stop-function)

time ranges

0,1s to 59min 59,9sec (100ms resolution)
1s to 99h 95min 59sec (1s resolution)

0,1s to 59min 59,9sec (100ms resolution)
1s to 99h 95min 59sec (1s resolution)

factory default control input setting

Control input I1: RESET
Connected: galvanic separated; terminals 28-29
Typ: S0 (DIN 43864); 15mA DC / 24V DC

Control input I1: RESET
Connected: galvanic separated; terminals 28-29
Typ: S0 (DIN 43864); 15mA DC / 24V DC

Control input I2: TRIGGER
Connected: galvanic separated; terminals 30-31
Typ: S0 (DIN 43864); 15mA DC / 24V DC

Control input I2: TRIGGER
Connected: galvanic separated; terminals 30-31
Typ: S0 (DIN 43864); 15mA DC / 24V DC

Control input I3: STOP
Connected: galvanic separated; terminals 32-33
Typ: S0 (DIN 43864); 15mA DC / 24V DC

Control input I3: STOP
Connected: galvanic separated; terminals 32-33
Typ: S0 (DIN 43864); 15mA DC / 24V DC

selectable Input functions

RESTART / STEP BACK • MANUAL • PROGRAMME CHANCE

RESTART / STEP BACK • MANUAL • PROGRAMME CHANCE

Supply

110VAC
terminals A1-A2

230VAC
terminals A1-A2

Output

8 potential free NO contact 230V AC, 3A
1 potential free NC contact 230V AC, 3A

8 potential free NO contact 230V AC, 3A
1 potential free NC contact 230V AC, 3A

Width

157,5mm

157,5mm

Certificates

CE

CE

Mechanical design

Self-extinguishing plastic housing, IP rating IP40 • Mounted on DIN-Rail TS 35 in accordance with EN 60715 • Mounting position: any • Shockproof terminal connection according to VBG 4, IP rating IP20 • Tightening torque max. 1Nm

Terminal capacity

1 x 0,5 to 2,5mm² with/without multicore cable end • 2 x 0,5 to 1,5mm² with/without multicore cable end

Ambient conditions

Ambient temperature: 0 to 50°C (in accordance with IEC 60068-1) • Storage temperature: -25 to +70°C • Transport temperature: -25 to +70°C • relative humidity: 15% to 85% (in accordance with IEC 60721-3-3 class 3K3) • Pollution degree: 2, if built in 3 (in accordance with IEC 60664-1)

Accessories

-

Dimensions

The 8 normally open contacts, as well as the alarm or synchronisation contact, are operated according to the internally saved, time-dependent sequences of steps (programmes). The sequences can run once (E) or cyclically (Z). The individual steps are defined by a programmed time interval and the associated condition of all output relays (output mask). Any changes to the condition of the output relays therefore require the programming of a new step.

The time-controlled processing of the sequence can be influenced by using the 3 input channels. The product is supplied with a factory default setting.

Control input

factory default
RESET, TRIGGER, STOP

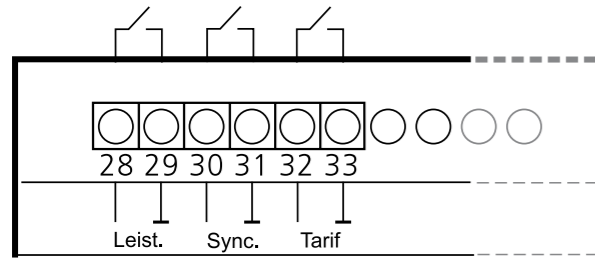

Outputs

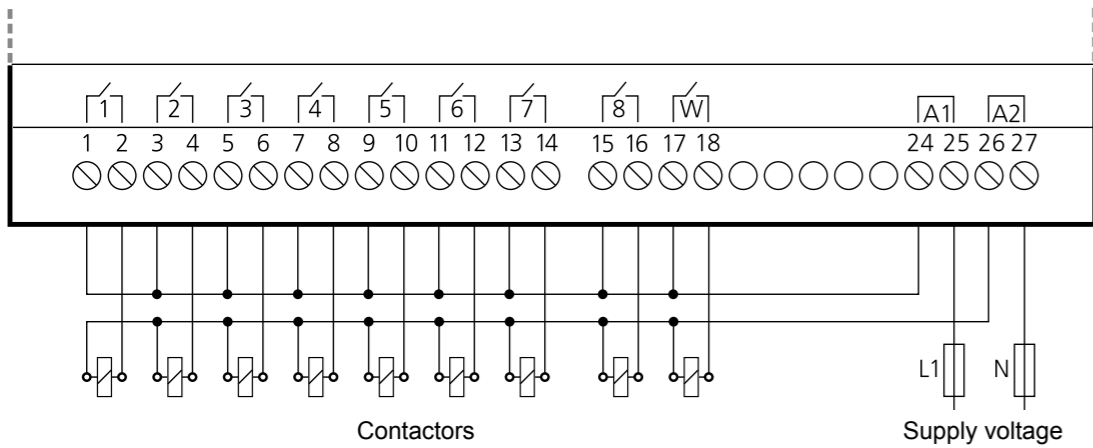

Width 157,5mm

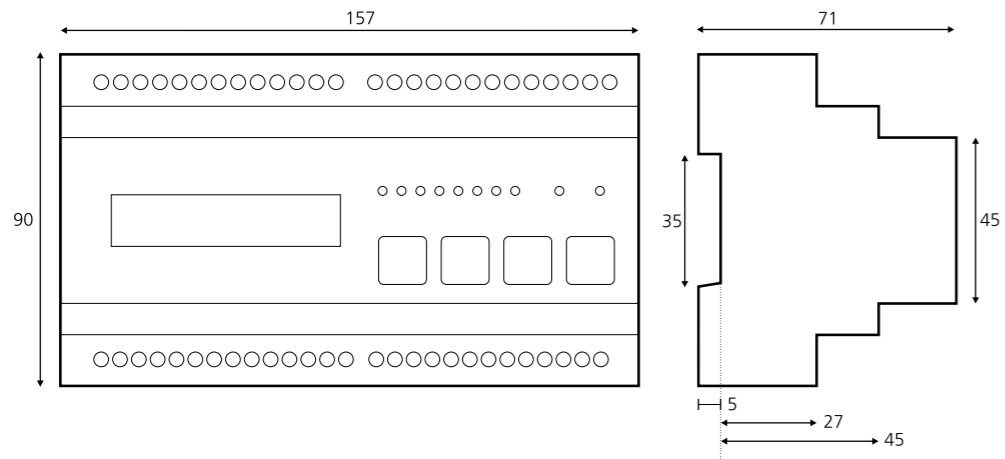

Functions



Pump Alternator Series GAMMA

Alternating or parallel operation of motors

- Alternated access of two pumps or other devices
- Even distribution of duty
- Parallel duty at high demand
- Operation using 1 or 2 input signals (two modes of operation)
- Timing offset of the two loads to avoid water hammer effects
- Supply voltage selectable via TR2 PowerModules or DC power supply
- 2 separate change over relays for device control
- Width 22,5mm
- Industrial design

Connections

Type

G2ASMA20



Art.No. (PQ1)

122000

Art.No. (PQ10)

-

EAN13-Code

900866200033

Controls

TIME/MODE

Indicators (LEDs)

U/t • Failure • R1 • R2

Functions

One of two redundant motors will operate on demand signalled by input Y1. Successive requests will operate the motors in an alternating sequence (sharing the duty between the devices). On demand both devices (pumps) will operate in parallel:

Mode A (parallel operation by separate input signal): Input Y2 initiates parallel operation. Without signal at input Y2, only one single motor will operate at each request.

Mode B (parallel operation by timing): If an operation request on input Y1 exceeds the adjusted delay, the unit will start the second motor for parallel operation.

Time ranges

t_1 (for parallel operation): 2s to 5min (only for mode B)
 t_2 (offset timing): 2s fixed

Control input

control input Y1: request for operation; terminals Y1-Y3
control input Y2: parallel operation (Mode A only); terminals Y2-Y3
input circuits galvanic separated

Supply

PowerModule TR2 or SNT2
terminals A1-A2

Output

2 potential free CO contacts
250V AC, 5A

Width

22,5mm

Certificates

CE

Mechanical design

Self-extinguishing plastic housing, IP rating IP40 • Mounted on DIN-Rail TS 35 in accordance with EN 60715 • Mounting position any • Shockproof terminal connection according to VBG 4 (PZ1 required) • IP rating IP20 • Tightening torque max. 1Nm.

Terminal capacity

1 x 0,5 to 2,5mm² with/without multicore cable end • 1 x 4mm² without multicore cable end • 2 x 0,5 to 1,5mm² with/without multicore cable end • 2 x 2,5mm² flexible without multicore cable end

Ambient conditions

Ambient temperature: -25 to 55°C (in accordance with IEC 60068-1); -25 to 40°C (in accordance with UL 508) • Storage temperature: -25 to +70°C • Transport temperature: -25 to +70°C • relative humidity: 15% to 85% (in accordance with IEC 60721-3-3 class 3K3) • Pollution degree: 3 (in accordance with IEC 60664-1) • Vibration resistance: 10 to 55Hz 0,35mm (in accordance with IEC 60068-2-6) • Shock resistance: 15g 11ms (in accordance with IEC 60068-2-27)

Accessories

PowerModule TR2 (12 - 440V AC) • DC power supply SNT2 24VDC

Dimensions

The Pump-Alternator is sensitive to one (mode B) or two (mode A) digital input signals. Each of the two output relays activates one of the two devices (usually pumps or motors) driven. The two outputs (Rel.1 and Rel. 2), are equally configured and interchangeable. In case of request for operation (Y1-Y3 linked by external contact) one of the output relays energises as long as the signal persists on input (Y1). Next time there is a request for operation the alternate output operates in the same manner. This way both connected devices (pumps or motors) will share load.

The information about, which output has done the first cycle after a power reset, is stored in a non-volatile memory. Next time after a power reset the other output will do the first cycle.

There is no definite delivery status about which of the two outputs will operate at the first occasion.

Mode and time setting can be done with a screwdriver at the front of the G2ASMA20. Control by supply voltage.

Functions

Modus A

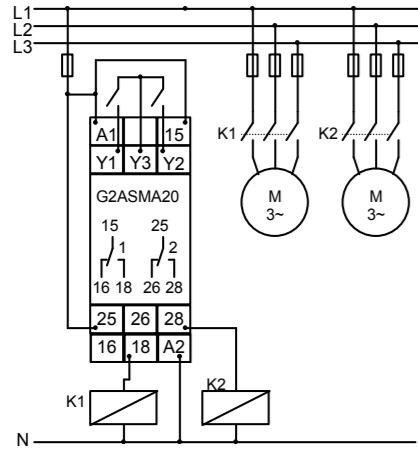

Modus B

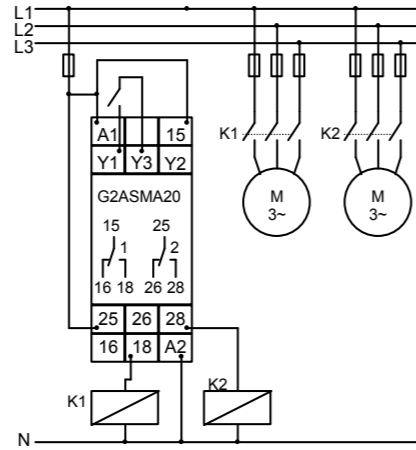

Connections

Control by supply voltage

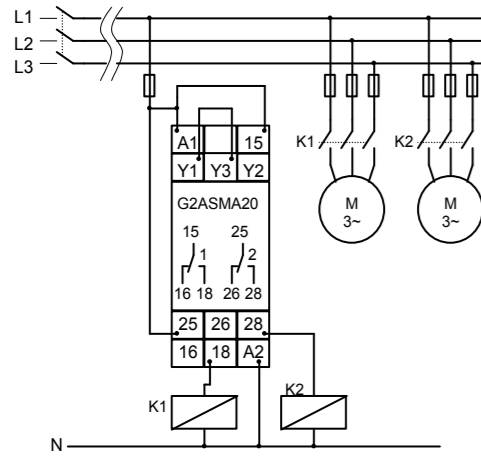

Connections

Width 22,5mm

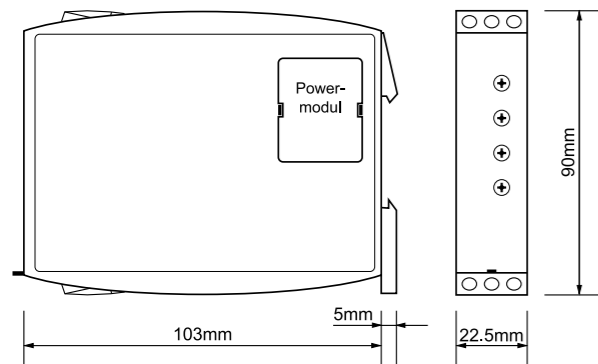

Dimensions

POWER ELECTRONICS



OVERVIEW

Page

Softstarter

Devices for different power classes are available for continuously optimized startups and shutdowns and for eliminating sudden stresses on conveyor systems, elevators and pumps. Different models ranging from compact devices with built-in bypass contactor through to large modular units with current-limited startup help to reduce maintenance costs.

| | |
|---------------------|-----|
| - Series: TSG/MSG | 210 |
| - Series: EUROSTART | 211 |
| - Series: ESG | 212 |

Braking Units

The compact braking units from TELE can be used to brake a wide variety of motor types easily, quickly and safely without mechanical wear. Motors rated up to 400kW are braked by an electromagnetic field without additional mechanical components. Changeover delays and interlocks ensure braking is performed safely.

| | |
|---------------|-----|
| - Series: MBG | 214 |
| - Series: BG | 214 |

Thyristor Control Units

A simple, systematic and economical approach is available for low-cost control and efficient regulation of ventilation, heating and lighting systems. For continuous and demand-based control for single- and three-phase loads it is possible to use phase control or in the case of heater elements, multicycle control. By eliminating wear, you increase availability and reduce costs.

| | |
|----------------|-----|
| - Series: TST | 215 |
| - Series: ESGT | 216 |



Softstarter Series TSG, MSG

Compact design

- Motor power 1,5 - 11kW
- Nominal voltage 400V AC or 230V (TSG)
- 1-phase and 3-phase control
- Reduced mechanical stress on drives (MSG)
- Softstop (MSG)
- PTC-Input (MSG 5,5/MSG 11)
- DIN rail mounting
- Integrated bypass contactor



Softstarter TSG and MSG

| Motor control | Nominal current | Nominal motor power | Dimension H x B x T [mm] | Weight | Type | Art.No. |
|---------------|-----------------|---------------------|--------------------------|--------|------------------|---------|
| 1-phase | 5A | 1,3kW (1~ 230V) | 75 x 22,5 x 111 | 0,2kg | TSG 2,2 230VAC | 490251 |
| | 5A | 2,2kW (3~ 400V) | 75 x 22,5 x 111 | 0,2kg | TSG 2,2 400VAC | 490250 |
| 3-phase | 6A | 3kW* | 76 x 45 x 117 | 0,33kg | MSG 3-3s 400VAC | 490000 |
| | 6A | 3kW | 76 x 45 x 117 | 0,33kg | MSG 3-30s 400VAC | 490002 |
| | 11A | 5,5kW | 76 x 70 x 117 | 0,41kg | MSG 5,5 400VAC | 490007 |
| | 22A | 11kW | 76 x 100 x 117 | 0,62kg | MSG 11 400VAC | 490008 |

Accessories

| | Type | Art.No. |
|--------------------------------|------------|---------|
| Front cover MSG 3 (sealable) | FA-MSG 3 | 490245 |
| Front cover MSG 5,5 (sealable) | FA-MSG 5,5 | 490246 |
| Front cover MSG 11 (sealable) | FA-MSG 11 | 490247 |

* Max. start time 3s



Softstarter Series EUROSTART

Compact design

- Motor power 1,5 - 75kW
- Nominal voltage 110 - 500V AC
- 3-phase control
- W3C-connection possible
- Softstop

EUROSTART



Softstarter EUROSTART

| Motor control | Nominal current | Nominal motor power | Dimension H x B x T [mm] | Weight | Type | Art.No. |
|---------------|-----------------|---------------------|--------------------------|--------------|----------------|---------|
| 3-phase | 4A | 1,5kW | 200 x 83 x 106 | 1,2kg | EUROSTART 1,5 | 490133 |
| | 5A | 2,2kW | 200 x 83 x 106 | 1,2kg | EUROSTART 2,2 | 490134 |
| | 7A | 3,0kW | 200 x 83 x 106 | 1,2kg | EUROSTART 3 | 490136 |
| | 9A | 4,0kW | 200 x 83 x 106 | 1,2kg | EUROSTART 4 | 490135 |
| | 12A | 5,5kW | 200 x 83 x 106 | 1,2kg | EUROSTART 5,5 | 490137 |
| | 16A | 7,5kW | 200 x 85 x 205 | 2,2kg | EUROSTART 7,5 | 490139 |
| | 23A | 11kW | 200 x 85 x 205 | 2,2kg | EUROSTART 11 | 490142 |
| | 31A | 15kW | 200 x 85 x 205 | 2,2kg | EUROSTART 15 | 490145 |
| | 39A | 18,5kW | 200 x 85 x 205 | 2,2kg | EUROSTART 18,5 | 490147 |
| | 46A | 22kW | 200 x 85 x 205 | 2,2kg | EUROSTART 22 | 490149 |
| | 64A | 30kW | 200 x 360 x 140 | 4,5kg | EUROSTART 30 | 490159 |
| | 77A | 37kW | 200 x 360 x 140 | 4,5kg | EUROSTART 37 | 490175 |
| | 94A | 45kW | 200 x 360 x 140 | 4,5kg | EUROSTART 45 | 490180 |
| 115A | 55kW | 200 x 360 x 140 | 4,5kg | EUROSTART 55 | 490185 | |
| 155A | 75kW | 200 x 360 x 140 | 4,5kg | EUROSTART 75 | 490189 | |

Options (integrated in the device)

| | Type | Art.No. |
|--|-------------|---------|
| Duty for motor powers 30-90kW (forced ventilation) | /DB EURO-30 | AS0023 |

Softstarter Series ESG

Open design

- Motor power 2,2 - 560kW
- Nominal voltage 400 - 500V AC
- 3-phase control
- W3C-connection possible
- Softstop
- Current limitation (ESG-I)



**AD
BREAK**

Softstarter ESG

| Motor control | Nominal current | Nominal motor power | Dimension H x B x T [mm] | Weight | Type | Art.No. |
|---|-----------------|---------------------|--------------------------|---------------|----------------|---------|
| 3-phase; without current limitation | 5A | 2,2kW | 200 x 140 x 115 | 1,3kg | ESG 2,2-400 | 490010 |
| | 6A | 3kW | 200 x 140 x 115 | 1,4kg | ESG 3-400 | 490015 |
| | 8,5A | 4kW | 200 x 140 x 115 | 1,5kg | ESG 4-400 | 490020 |
| | 12A | 5,5kW | 160 x 260 x 170 | 2,8kg | ESG 5,5-400 | 490025 |
| | 15A | 7,5kW | 160 x 260 x 170 | 2,8kg | ESG 7,5-400 | 490030 |
| | 22A | 11kW | 160 x 260 x 170 | 3kg | ESG 11-400 | 490035 |
| | 30A | 15kW | 160 x 260 x 170 | 3kg | ESG 15-400 | 490040 |
| | 40A | 18,5kW | 160 x 260 x 170 | 3kg | ESG 18,5-400 | 490045 |
| | 45A | 22kW | 160 x 260 x 170 | 3,5kg | ESG 22-400 | 490050 |
| | 60A | 30kW | 200 x 360 x 200 | 8kg | ESG 30-400 | 490055 |
| | 70A | 37kW | 200 x 360 x 200 | 8,5kg | ESG 37-400 | 490060 |
| | 90A | 45kW | 200 x 360 x 200 | 8,5kg | ESG 45-400 | 490065 |
| | 110A | 55kW | 200 x 360 x 200 | 9kg | ESG 55-400 | 490070 |
| | 150A | 75kW | 200 x 360 x 200 | 9,5kg | ESG 75-400 | 490075 |
| 3-phase; with current limitation | 5A | 2,2kW | 200 x 140 x 115 | 1,3kg | ESG-I 2,2-400 | 490011 |
| | 6A | 3kW | 200 x 140 x 115 | 1,4kg | ESG-I 3-400 | 490061 |
| | 8,5A | 4kW | 200 x 140 x 115 | 1,5kg | ESG-I 4-400 | 490021 |
| | 12A | 5,5kW | 160 x 260 x 170 | 2,8kg | ESG-I 5,5-400 | 490026 |
| | 15A | 7,5kW | 160 x 260 x 170 | 2,8kg | ESG-I 7,5-400 | 490031 |
| | 22A | 11kW | 160 x 260 x 170 | 3kg | ESG-I 11-400 | 490036 |
| | 30A | 15kW | 160 x 260 x 170 | 3kg | ESG-I 15-400 | 490041 |
| | 40A | 18,5kW | 160 x 260 x 170 | 3kg | ESG-I 18,5-400 | 490046 |
| | 45A | 22kW | 160 x 260 x 170 | 3,5kg | ESG-I 22-400 | 490051 |
| | 60A | 30kW | 200 x 360 x 200 | 8kg | ESG-I 30-400 | 490056 |
| | 70A | 37kW | 200 x 360 x 200 | 8,5kg | ESG-I 37-400 | 490063 |
| | 90A | 45kW | 200 x 360 x 200 | 8,5kg | ESG-I 45-400 | 490067 |
| | 110A | 55kW | 200 x 360 x 200 | 9kg | ESG-I 55-400 | 490072 |
| | 150A | 75kW | 200 x 360 x 200 | 9,5kg | ESG-I 75-400 | 490076 |
| | 180A | 90kW | 200 x 360 x 200 | 10,5kg | ESG-I 90-400 | 490081 |
| | 200A | 110kW | 400 x 360 x 240 | 18kg | ESG-I 110-400 | 490085 |
| | 230A | 140kW | 400 x 360 x 240 | 18kg | ESG-I 140-400 | 490093 |
| | 300A | 160kW | 545 x 600 x 346 | 41kg | ESG-I 160-400 | 490096 |
| | 350A | 200kW | 545 x 600 x 346 | 41kg | ESG-I 200-400 | 490101 |
| | 450A | 250kW | 545 x 600 x 346 | 42kg | ESG-I 250-400 | 490110 |
| 550A | 315kW | 545 x 600 x 346 | 42kg | ESG-I 315-400 | 490111 | |
| 700A | 355kW | 545 x 600 x 346 | 44kg | ESG-I 355-400 | 490112 | |
| 800A | 400kW | 715 x 850 x 396 | 51kg | ESG-I 400-400 | 490113 | |
| 1100A | 560kW | 715 x 850 x 396 | 53kg | ESG-I 560-400 | 490114 | |

Options (integrated in the device)

| | Type | Art.No. |
|---|-------------|---------|
| Duty for motor powers 2,2 - 4kW (forced ventilation) | /DB ESG-2,2 | AS0015 |
| Duty for motor powers 5,5 - 22kW (forced ventilation) | /DB ESG-5,5 | AS0016 |
| Duty for motor powers 30 - 75kW (forced ventilation) | /DB ESG-30 | AS0017 |
| Duty for motor powers 90 - 140kW (forced ventilation) | /DB ESG-90 | AS0018 |
| Braking module (ESG 3 and higher) | /BG ESG | AS0019 |
| Control voltage; 24V DC | /24VDC ESG | AS0020 |
| Control voltage; 400V AC | /400VAC ESG | AS0021 |

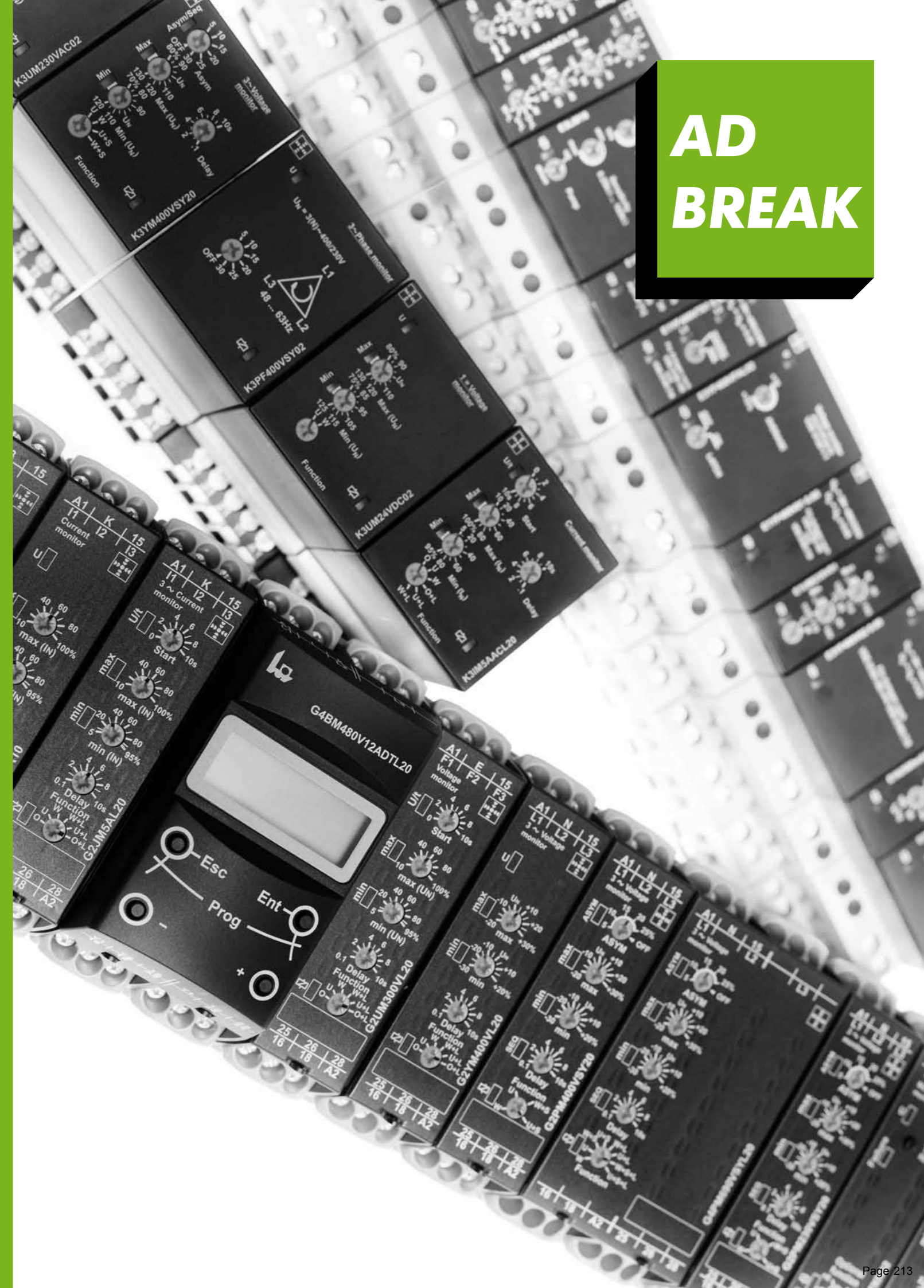

Braking Units Series MBG, BG

- Electronic motor brake
- No additional braking accessory required
- Integrated brake contactor (MBG)
- Integrated motor contactor control

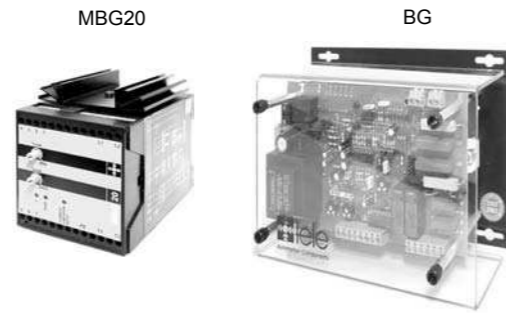

Motor brake

| | Recommended motor power | Max. braking current | Dimension H x B x T [mm] | Weight | Type | Art.No. |
|-----------------------|-------------------------|----------------------|--------------------------|---------|---------------|---------|
| Compact Design | 2,2kW | 10A | 76 x 45 x 117 | 0,29kg | MBG10 230V AC | 499110 |
| | 5,5kW | 20A | 101 x 70 x 117 | 0,51kg | MBG20 400V AC | 499111 |
| | 11kW | 35A | 101 x 101 x 117 | 0,68kg | MBG35 400V AC | 499112 |
| Open Design | 4kW | 18A | 140 x 200 x 115 | 1,1kg | BG 20 | 499950 |
| | 7,5kW | 32A | 140 x 200 x 115 | 1,2kg | BG 35 | 499951 |
| | 15kW | 60A | 195 x 260 x 170 | 2,3kg | BG 60 | 499982 |
| | 22kW | 100A | 195 x 260 x 170 | 2,5kg | BG 100 | 499981 |
| | 30kW | 150A | 195 x 260 x 170 | 2,9kg | BG 150 | 499983 |
| | 55kW | 220A | 195 x 260 x 170 | 3,4kg | BG 220 | 499984 |
| | 75kW | 300A | 195 x 260 x 170 | 3,4kg | BG 300 | 499955 |
| | 100kW | 400A | 235 x 360 x 200 | 6,9kg | BG 400 | 499956 |
| | 140kW | 500A | 235 x 360 x 200 | 6,9kg | BG 500 | 499957 |
| | 200kW | 750A | 235 x 360 x 200 | 7,4kg | BG 750 | 499977 |
| | 250kW | 1000A | 235 x 360 x 200 | 7,6kg | BG 1000 | 499959 |
| | 315kW | 1500A | 360 x 400 x 240 | 9,2kg | BG 1500 | 499985 |
| 400kW | 2000A | 360 x 400 x 240 | 10,5kg | BG 2000 | 499986 | |



Thyristor control unit Series TST

Compact design

- Max. load current 5 - 50A
- 1-phase control (TST1) and 3-phase control (TST3)
- Phase clipping or burst control switchable (TST3)
- Multi control signal (TST3)
- For resistive and inductive loads



Thyristor control unit (Compact Design)

| | Load | max. | Dimension H x B x T [mm] | Type | Art.No. |
|---|---------------------|------|--------------------------|--------------------|---------|
| Phase clipping control | 1-phase | 5A | 130 x 93 x 103 | TST1 05 | 499996 |
| | | 15A | 130 x 93 x 103 | TST1 15 | 499991 |
| | | 25A | 130 x 93 x 103 | TST1 25 | 499992 |
| | | 35A | 130 x 93 x 103 | TST1 35 | 499993 |
| | | 50A | 130 x 93 x 103 | TST1 50 | 499994 |
| Burst control | 1-phase | 5A | 130 x 93 x 103 | TST1-SP 05 | 499996S |
| | | 15A | 130 x 93 x 103 | TST1-SP 15 | 499991S |
| | | 25A | 130 x 93 x 103 | TST1-SP 25 | 499992S |
| | | 35A | 130 x 93 x 103 | TST1-SP 35 | 499993S |
| | | 50A | 130 x 93 x 103 | TST1-SP 50 | 499994S |
| Phase clipping- and Burst control switchable | 3-phase | 5A | 200 x 140 x 135 | TST3 05 3x400/230V | 499053 |
| | | 15A | 200 x 140 x 135 | TST3 15 3x400/230V | 499050 |
| | 3- or 4-wire system | 25A | 200 x 140 x 135 | TST3 25 3x400/230V | 499051 |
| | | 35A | 200 x 140 x 135 | TST3 35 3x400/230V | 499052 |
| | | 50A | 200 x 140 x 135 | TST3 50 3x400/230V | 499054 |

Options

| for Series | | Type | Art.No. |
|-------------|--|-----------------|---------|
| TST1 | Internal power supply 230V AC | /IV 230VAC TST1 | AS0029 |
| | Internal power supply 400V AC | /IV 400VAC TST1 | AS0033 |
| TST3 | Internal power supply 400V AC (integrated in the device) | /400VAC TST3 | AS0032 |

Thyristor control unit Series ESGT

Open design

- Max. Load current 8 - 1000A
- 3-phase control
- Additional options provided by various function modules
- For resistive or inductive load



Thyristor control unit Series ESGT

Open design

- Load current 8 - 350A
- 1-phase control
- Options provided by various function modules
- For resistive or inductive load

Three-phase AC-controller (Open Design)

| | Load | Max. load current | Dimension H x B x T [mm] | Weight | Type | Art.No. |
|-------------------------------|--------------------------------|-------------------|--------------------------|--------|----------------|---------|
| Phase clipping control | 3-phase 3- or 4-wire system | 8A | 140 x 200 x 115 | 1,3kg | ESGT 08 | 490200 |
| | | 15A | 195 x 260 x 170 | 1,9kg | ESGT 15 | 490201 |
| | | 25A | 195 x 260 x 170 | 1,9kg | ESGT 25 | 490213 |
| | | 35A | 195 x 260 x 170 | 2,3kg | ESGT 35 | 490203 |
| | | 50A | 195 x 260 x 170 | 2,3kg | ESGT 50 | 490216 |
| | | 60A | 195 x 260 x 170 | 2,4kg | ESGT 60 | 490217 |
| | | 75A | 235 x 360 x 200 | 3,7kg | ESGT 75 | 490218 |
| | | 90A | 235 x 360 x 200 | 3,9kg | ESGT 90 | 490220 |
| | | 120A | 235 x 360 x 200 | 3,9kg | ESGT 120 | 490205 |
| | | 160A | 235 x 360 x 200 | 4,2kg | ESGT 160 | 490210 |
| | | 220A | 235 x 360 x 200 | 8,5kg | ESGT 220 | 490212 |
| | | 280A | 235 x 360 x 200 | 8,8kg | ESGT 280 | 490214 |
| | | 350A | 235 x 360 x 200 | 9,3kg | ESGT 350 | 490215 |
| | | 420A | 235 x 360 x 200 | 9,8kg | ESGT 420 | 490370 |
| | | 560A | 235 x 360 x 200 | 18kg | ESGT 560 | 490373 |
| | | 720A | 235 x 360 x 200 | 18kg | ESGT 720 | 490376 |
| | | 1000A | 235 x 360 x 200 | 18,9kg | ESGT 1000 | 490379 |
| Burst control | 3-phase 3-wire system | 8A | 140 x 200 x 115 | 1,3kg | ESGT-SP 08 | 490341 |
| | | 15A | 195 x 260 x 170 | 1,9kg | ESGT-SP 15 | 490343 |
| | | 25A | 195 x 260 x 170 | 1,9kg | ESGT-SP 25 | 490346 |
| | | 35A | 195 x 260 x 170 | 2,3kg | ESGT-SP 35 | 490349 |
| | | 50A | 195 x 260 x 170 | 2,3kg | ESGT-SP 50 | 490351 |
| | | 60A | 195 x 260 x 170 | 2,4kg | ESGT-SP 60 | 490353 |
| | | 75A | 235 x 360 x 200 | 3,7kg | ESGT-SP 75 | 490354 |
| | | 90A | 235 x 360 x 200 | 3,9kg | ESGT-SP 90 | 490355 |
| | | 120A | 235 x 360 x 200 | 3,9kg | ESGT-SP 120 | 490342 |
| | | 160A | 235 x 360 x 200 | 4,2kg | ESGT-SP 160 | 490344 |
| | | 220A | 235 x 360 x 200 | 8,5kg | ESGT-SP 220 | 490345 |
| | | 280A | 235 x 360 x 200 | 8,8kg | ESGT-SP 280 | 490348 |
| | | 350A | 235 x 360 x 200 | 9,3kg | ESGT-SP 350 | 490350 |
| | | 420A | 235 x 360 x 200 | 9,8kg | ESGT-SP 420 | 490371 |
| | | 560A | 235 x 360 x 200 | 18kg | ESGT-SP 560 | 490374 |
| | | 720A | 235 x 360 x 200 | 18kg | ESGT-SP 720 | 490377 |
| | | 1000A | 235 x 360 x 200 | 18,9kg | ESGT-SP 1000 | 490380 |
| Burst control | 3-phase 4-wire system | 8A | 140 x 200 x 115 | 1,3kg | ESGT-SP-N 08 | 490356 |
| | | 15A | 195 x 260 x 170 | 1,9kg | ESGT-SP-N 15 | 490358 |
| | | 25A | 195 x 260 x 170 | 1,9kg | ESGT-SP-N 25 | 490361 |
| | | 35A | 195 x 260 x 170 | 2,3kg | ESGT-SP-N 35 | 490363 |
| | | 50A | 195 x 260 x 170 | 2,3kg | ESGT-SP-N 50 | 490365 |
| | | 60A | 195 x 260 x 170 | 2,4kg | ESGT-SP-N 60 | 490366 |
| | | 75A | 235 x 360 x 200 | 3,7kg | ESGT-SP-N 75 | 490367 |
| | | 90A | 235 x 360 x 200 | 3,9kg | ESGT-SP-N 90 | 490368 |
| | | 120A | 235 x 360 x 200 | 3,9kg | ESGT-SP-N 120 | 490357 |
| | | 160A | 235 x 360 x 200 | 4,2kg | ESGT-SP-N 160 | 490359 |
| | | 220A | 235 x 360 x 200 | 8,5kg | ESGT-SP-N 220 | 490360 |
| | | 280A | 235 x 360 x 200 | 8,8kg | ESGT-SP-N 280 | 490362 |
| | | 350A | 235 x 360 x 200 | 9,3kg | ESGT-SP-N 350 | 490364 |
| | | 420A | 235 x 360 x 200 | 9,8kg | ESGT-SP-N 420 | 490372 |
| | | 560A | 235 x 360 x 200 | 18kg | ESGT-SP-N 560 | 490375 |
| | | 720A | 235 x 360 x 200 | 18kg | ESGT-SP-N 720 | 490378 |
| | | 1000A | 235 x 360 x 200 | 18,9kg | ESGT-SP-N 1000 | 490381 |

AC-controller (Open Design)

| | Load | Max. load current | Dimension H x B x T [mm] | Weight | Type | Art.No. | | |
|-------------------------------|-----------------|----------------------|--------------------------|--------|-----------------|---------|----------------|--------|
| Phase clipping control | 1-phase | 8A | 140 x 200 x 115 | 1,0kg | ESGT-1PH 08 | 490300 | | |
| | | 15A | 140 x 200 x 115 | 1,1kg | ESGT-1PH 15 | 490301 | | |
| | | 25A | 140 x 200 x 115 | 1,5kg | ESGT-1PH 25 | 490310 | | |
| | | 35A | 140 x 200 x 115 | 1,6kg | ESGT-1PH 35 | 490313 | | |
| | | 50A | 195 x 260 x 170 | 2,8kg | ESGT-1PH 50 | 490315 | | |
| | | 60A | 195 x 260 x 170 | 2,8kg | ESGT-1PH 60 | 490316 | | |
| | | 75A | 195 x 260 x 170 | 3kg | ESGT-1PH 75 | 490317 | | |
| | | 90A | 195 x 260 x 170 | 3kg | ESGT-1PH 90 | 490318 | | |
| | | 125A | 195 x 260 x 170 | 3kg | ESGT-1PH 125 | 490320 | | |
| | | 220A | 235 x 360 x 200 | 7,8kg | ESGT-1PH 220 | 490224 | | |
| | | 300A | 235 x 360 x 200 | 8,8kg | ESGT-1PH 300 | 490312 | | |
| | | 350A | 235 x 360 x 200 | 9,4kg | ESGT-1PH 350 | 490314 | | |
| | | Burst control | 1-phase | 8A | 140 x 200 x 115 | 1,0kg | ESGT-1PH-SP 08 | 490319 |
| | | | | 15A | 140 x 200 x 115 | 1,1kg | ESGT-1PH-SP 15 | 490321 |
| 25A | 140 x 200 x 115 | | | 1,5kg | ESGT-1PH-SP 25 | 490323 | | |
| 35A | 140 x 200 x 115 | | | 1,6kg | ESGT-1PH-SP 35 | 490325 | | |
| 50A | 195 x 260 x 170 | | | 2,8kg | ESGT-1PH-SP 50 | 490327 | | |
| 60A | 195 x 260 x 170 | | | 2,8kg | ESGT-1PH-SP 60 | 490328 | | |
| 75A | 195 x 260 x 170 | | | 3kg | ESGT-1PH-SP 75 | 490329 | | |
| 90A | 195 x 260 x 170 | | | 3kg | ESGT-1PH-SP 90 | 490330 | | |
| 125A | 195 x 260 x 170 | | | 3kg | ESGT-1PH-SP 125 | 490326 | | |
| 220A | 235 x 360 x 200 | | | 7,8kg | ESGT-1PH-SP 220 | 490322 | | |
| 300A | 235 x 360 x 200 | | | 8,8kg | ESGT-1PH-SP 300 | 490324 | | |
| 350A | 235 x 360 x 200 | | | 9,4kg | ESGT-1PH-SP 350 | 490314S | | |

Options

| | Load | Type | Art.No. |
|---------------------------------|---------|---|-------------------------|
| Integrated in the device | 3-phase | Constant-current regulation, 3 current transformers | /J ESGT AS0008 |
| | | Constant-voltage regulation | /U ESGT AS0009 |
| | | Current-limit control with high-speed disconnection | /IB ESGT AS0010 |
| | | Current output (0-100% nominal current equ. 0-10V) | /AI ESGT AS0011 |
| | | Voltage output 0-10V trimmable to nominal voltage | /AU ESGT AS0012 |
| | | Control voltage 24V DC | /24V DC ESGT AS0013 |
| | | Control voltage 400V AC | /400VAC ESGT AS0014 |
| | 1-phase | Constant-current regulation, current transformer included | /J ESGT-1PH AS0001 |
| | | Constant-voltage regulation | /U ESGT-1PH AS0002 |
| | | Current-limit control with high-speed disconnection | /IB ESGT-1PH AS0003 |
| | | Current output (0-100% nominal current equ. 0-10V) | /AI ESGT-1PH AS0004 |
| | | Voltage output 0-10V trimmable to nominal voltage | /AU ESGT-1PH AS0005 |
| | | Control voltage 24V DC | /24V DC ESGT-1PH AS0006 |
| | | Control voltage 400V AC | /400VAC ESGT-1PH AS0007 |

Accessories

| | Type | Art.No. |
|--|------------|---------|
| Remote potentiometer, scale 1-10, 10KOhm | R20 10KOHM | 282131 |

**SWITCHING
RELAYS
AND OTHER
AUTOMATION
COMPONENTS**



OVERVIEW



| | | Page |
|------------------------------|---|------|
| Switching Relays | - Miniature Relays: RA and RM | 220 |
| | - Industrial Relays: RT | 222 |
| | - PCB Relays: RP | 223 |
| | - Interface Relays: SKR | 224 |
| Coupling Units | - Coupling Relays: ENYA | 225 |
| | - Automatic-Manual-OFF relay: OCTO | 227 |
| | - Analogue data encoder: OCTO | 229 |
| | - Levelswitch: OCTO | 231 |
| | - Diode gate / logical operation: TREND | 233 |
| | - Multicoupling relay: VOX | 235 |
| Signal Converter | - Signalamplifier: M1 | 237 |
| | - Loop-Powered Isolator: M1 | 239 |
| Mains decoupler | - Series: OCTO | 241 |
| Safety Relays | - Safety Relays: S ² | 243 |
| | - Safety Relays: ZK | 243 |
| Digital Time Switches | - Series: TSC | 244 |
| Hour meters | - Series TBG and TBW | 245 |
| DC power supply | - Series: RNG | 246 |
| | - Switching power supply | 247 |

Switching Relays Series RA and RM

Miniature Relays

- 2 CO contacts, max. 12A switching current (Series RA)
- 4 CO contacts, max. 6A switching current (Series RM)
- Various LED and protection modules
- Hand operation

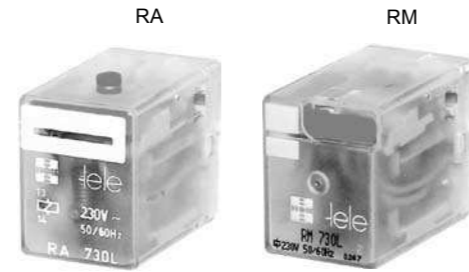

Miniature Relays

| Series | Contacts | Nominal voltage | LED | protection diode | gold-coated contacts | Type | Art.No. | |
|--------|----------|-----------------|-------------|------------------|----------------------|-------------|------------|----------|
| RA | 2 CO | AC | 24V | ■ | | RA 524L | 100623LD | |
| | | | 115V | ■ | | RA 615L | 100621LD | |
| | | | 230V | ■ | | RA 730L | 100624LD | |
| | | DC | 12V | ■ | | RA 012L | 100625LD | |
| | | | 24V | ■ | | RA 024L | 100622LD | |
| | | | 230V | ■ | | RA 730L | 100619LD | |
| | RM | 4 CO | AC | 12V | ■ | | RM 512L | 100612LD |
| | | | | 24V | ■ | | RM 524 | 100613 |
| | | | DC | 24V | ■ | | RM 524L | 100613LD |
| | | | | ■ | ■ | | RM 524.02L | 100613H |
| 48V | | | | ■ | | RM 548L | 100614LD | |
| 115V | | | | ■ | | RM 615L | 100618LD | |
| ■ | | | | ■ | | RM 615.02L | 100618H | |
| 230V | | | | ■ | | RM 730 | 100619 | |
| ■ | | | | | | RM 730L | 100619LD | |
| ■ | | | | ■ | | RM 730.02L | 100619HL | |
| 12V | | | | ■ | | RM 012L | 100601LD | |
| ■ | | | | ■ | ■ | RM 012.02LD | 100601HD | |
| 24V | | | | ■ | | RM 024 | 100603 | |
| ■ | | | | | | RM 024L | 100603LD | |
| ■ | ■ | | RM 024LD | 100604FD | | | | |
| ■ | ■ | ■ | RM 024.02LD | 100603HD | | | | |
| 48V | ■ | | RM 048L | 100602LD | | | | |
| ■ | ■ | ■ | RM 048.02LD | 100602HD | | | | |
| 60V | ■ | | RM 060L | 100616LD | | | | |
| ■ | ■ | ■ | RM 060.02LD | 100616HD | | | | |
| 110V | ■ | | RM 110L | 100617LD | | | | |
| ■ | ■ | ■ | RM 110.02LD | 100617HD | | | | |
| 220V | ■ | | RM 220L | 100620LD | | | | |
| ■ | ■ | ■ | RM 220.02LD | 100619HF | | | | |

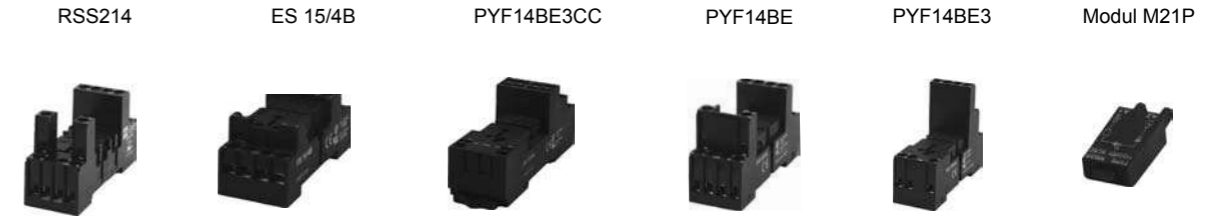

Relay socket

| Series | for series | Nominal voltage | max. current pro contact | Type | Art.No. |
|--------------|------------|-----------------|--------------------------|-----------------------|---------|
| PYF | RA, RM | 300V AC | 12A | PYF14BE (ES 15/4N) | 180134 |
| | | | 12A | PYF14BE3 (ES 15/4S) | 180145 |
| | | | 10A | PYF14BE3CC (ES 15/4G) | 180148 |
| (cage clamp) | | | | | |
| ES | RA, RM | 300V AC | 10A | ES 15/4B | 180046 |
| RSS214 | RM | 300V AC | 6A | RSS214 | 180050 |

Modules

| | for series | Nominal voltage | Type | Art.No. |
|----------------------|------------|------------------------|---------------|---------|
| Diode | PYF | 6 - 230V DC (+A2) | M21P | 180260 |
| | | 6 - 230V DC (+A1) | M21N | 180261 |
| LED (red) | PYF | 6 - 24V AC/DC (+A1) | M61R | 180265 |
| | | 110 - 230V AC/DC (+A1) | M63R | 180268 |
| LED (red) + Diode | PYF | 6 - 24V DC (+A2) | M31R | 180262 |
| | | 6 - 24V DC (+A1) | M41R | 180263 |
| LED (green) | RSS214 | 110 - 230V AC | EM 10 | 180307 |
| | | 6 - 24V AC/DC | EM 11 | 180308 |
| LED (green) + Diode | RSS214 | 6 - 24V DC (+A1) | EM 12 | 180309 |
| | | 110 - 240V AC | M53 | 180264 |
| RC-element | PYF | 110 - 240V AC | M53 | 180264 |
| | | RSS214 | 110 - 230V AC | EM 03 |
| Varistor | PYF | 24V AC | M71 | 180266 |
| | | 230V AC | M73 | 180267 |
| | RSS214 | 24V AC | EM 04 | 180301 |
| | | 230V AC | EM 05 | 180302 |
| Varistor + LED (red) | PYF | 110 - 230V AC | M93G | 180276 |
| Resistor | PYF | 110 - 230V AC | M103 | 180269 |

Accessories

| | for series | Type | Art.No. |
|--------------------------|----------------------------|----------|----------|
| Retaining clip (metal) | RSS214, ES, PYF | HB/RM-RA | 180032 |
| Retaining clip (plastic) | ES, PYF | HB/ES15 | P0000033 |
| Jumper link | RSS214 (5 Relays) | PB RSS5 | 180051 |
| End cover | for jumper link PB RSS5 | PBA RSS | 180052 |

Relaysets

| Contacts | Nominal voltage | Socket | Protection diode | Retaining clip HB/ES15 | Type | Art.No. |
|----------|-----------------|--------|------------------|------------------------|---------------------|---------|
| 4 CO | AC | 24V | ■ | ■ | SET RM524L+PYF14BE | 100670 |
| | | 24V | ■ | ■ | SET RM024LD+RSS214 | 100680 |
| | AC | 230V | ■ | ■ | SET RM024LD+PYF14BE | 100671 |
| | | | ■ | ■ | SET RM730L+PYF14BE | 100672 |

Switching Relays Series RT

Industrial Relays

- 2 or 3 CO contacts, max. 10A switching current
- 8-pin or 11-pin socket
- Position indicator
- Various LED and protection modules
- Hand operation



Industrial relays

| Pole | Nominal voltage | Contacts | | | protection | | Type | Art.No. | |
|--------|-----------------|----------|------|-------------|------------|-----------------|-------------|-------------|----------|
| | | 2 CO | 3 CO | gold-coated | LED | diode | | | |
| 8-pin | AC | 12V | ■ | | ■ | | RT 1.2.012L | 100508LD | |
| | | 24V | ■ | | ■ | | RT 1.2.024L | 100507LD | |
| | | 110V | ■ | | ■ | | RT 1.2.110L | 100505LD | |
| | | 230V | ■ | | ■ | | RT 1.2.230L | 100502LD | |
| | DC | 12V | ■ | | ■ | | RT 2.2.012L | 100517LD | |
| | | 24V | ■ | | ■ | | RT 2.2.024L | 100516LD | |
| | | 11-pin | AC | 24V | ■ | | ■ | RT 1.3.024L | 100526LD |
| | | | | 48V | ■ | | ■ | RT 1.3.048L | 100524LD |
| 11-pin | AC | 110V | ■ | | ■ | RT 1.3.110L | 100522LD | | |
| | | 230V | ■ | | ■ | RT 1.3.230 | 100521 | | |
| | | | ■ | | ■ | RT 1.3.230L | 100521LD | | |
| | | | ■ | ■ | ■ | RT 1.3.230.02L | 100521H | | |
| | | DC | 12V | ■ | | ■ | | RT 2.3.012L | 100536LD |
| | | | 24V | ■ | | ■ | | RT 2.3.024 | 100535 |
| | | ■ | | ■ | | RT 2.3.024L | 100535LD | | |
| | | ■ | | ■ | ■ | RT 2.3.024LD | 100535FD | | |
| | | ■ | ■ | ■ | ■ | RT 2.3.024.02LD | 100535H | | |
| | | 48V | ■ | | ■ | | RT 2.3.048L | 100533LD | |
| | 60V | ■ | | ■ | | RT 2.3.060L | 100532LD | | |
| | 110V | ■ | | | | RT 2.3.110 | 100531 | | |
| | 220V | ■ | | | | RT 2.3.220 | 100530 | | |

Relay sockets

| Series | for series | Nominal voltage | max. current pro contact | Type | Art.No. |
|--------|-------------------------------|-----------------|--------------------------|------------------|---------|
| PF | RT 8-pin | 300V AC | 10A | PF083BE (ES 8) | 180139 |
| | RT 11-pin, COMBI, KAPPA, PLUS | 300V AC | 10A | PF113BEM (ES 12) | 180136 |
| ES | RT 8-pin, COMBI | 300V AC | 10A | ES 9 | 180041 |
| R11X | RT 11-pin, KAPPA, PLUS | 300V AC | 10A | R11X | 180055 |

Modules

| | for series | Nominal voltage | Type | Art.No. |
|-----------|----------------|------------------------|-----------------|---------|
| LED | ES 9, PF113BEM | 6 - 24V AC/DC (+A1) | TYPE 61 (TVL 3) | 180234 |
| | | 110 - 230V AC/DC (+A1) | TYPE 91 (TVL 4) | 180235 |
| Diode | ES 9, PF113BEM | 6 - 230V DC (+A2) | TYPE 11 (TVD 2) | 180231 |
| | | 6 - 230V DC (+A1) | TYPE 21 (TVD 1) | 180230 |
| LED+Diode | ES 9, PF113BEM | 6 - 24V DC (+A2) | TYPE 31 (TVL 2) | 180233 |
| | | 6 - 24V DC (+A1) | TYPE 41 (TVL 1) | 180232 |
| RC-link | ES 9, PF113BEM | 110 - 240V AC | TYPE 51 (TVR) | 180236 |
| Varistor | ES 9, PF113BEM | 24V AC | TYPE 71 (TVV 1) | 180237 |
| | | 230V AC | TYPE 81 (TVV 2) | 180238 |

Accessories

| | for series | Type | Art.No. |
|----------------|-------------------------------|-------|---------|
| Retaining clip | PF083BE, PF113BEM, ES 9, R11X | HB/RT | 180043 |



Switching Relays Series RP

PCB Relays

- 1 CO contact, max. 16A switching current
- 2 CO contacts, max. 8A switching current
- Mounting in socket or on printed circuit boards (PCB)
- Relaysets with socket and retaining clip
- Various LED and protection modules

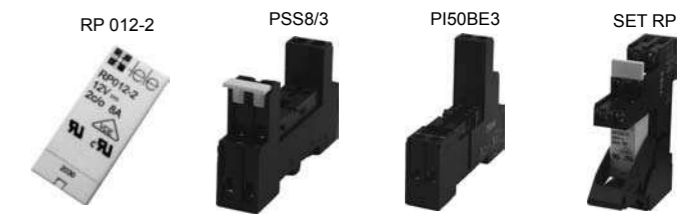

PCB relays

| Contacts | Nominal voltage | Current | gold-coated contacts | Type | Art.No. |
|----------|-----------------|---------|----------------------|-----------|---------|
| 1 CO | AC | 24V AC | 16A | RP 524-1 | 100431 |
| | | 230V AC | 16A | RP 730-1 | 100432 |
| | DC | 24V DC | 16A | RP 024-1 | 100430 |
| 2 CO | AC | 24V AC | 8A | RP 524-2 | 100417 |
| | | 115V AC | 8A | RP 615-2 | 100421 |
| | | 230V AC | 8A | RP 730-2 | 100418 |
| | DC | 12V DC | 8A | RP 730-hv | 100418H |
| | | | 8A | RP 012-2 | 100420 |
| | | 24V DC | 8A | RP 024-2 | 100416 |
| | | 8A | RP 024-hv | 100416H | |

Relay sockets

| Series | for Series | Nominal voltage | max. current pro contact | Type | Art.No. |
|--------|------------|-----------------|--------------------------|-------------------|---------|
| PI | RP | 300V AC | 12A | PI50BE (ES 50) | 180137 |
| | | | 12A | PI50BE3 (ES 50/3) | 180133 |
| PSS | RP | 300V AC | 12A | PSS8/3 | 180056 |

Modules

| Typ | for Series | Nominal voltage | Type | Art.No. |
|----------------------|------------|------------------------|-------|---------|
| Diode | PI | 6 - 230V DC (+A2) | M21P | 180260 |
| | | 6 - 230V DC (+A1) | M21N | 180261 |
| LED (red) | PI | 6 - 24V AC/DC (+A1) | M61R | 180265 |
| | | 110 - 230V AC/DC (+A1) | M63R | 180268 |
| LED (red) + Diode | PI | 6 - 24V DC (+A2) | M31R | 180262 |
| | | 6 - 24V DC (+A1) | M41R | 180263 |
| LED (green) | PSS | 110 - 230V AC | EM 10 | 180307 |
| | | 6 - 24V AC/DC | EM 11 | 180308 |
| LED (green) + Diode | PSS | 6 - 24V DC (+A1) | EM 12 | 180309 |
| | | | | |
| RC-link | PI | 110 - 240V AC | M53 | 180264 |
| | PSS | 110 - 230V AC | EM 03 | 180300 |
| Varistor | PI | 24V AC | M71 | 180266 |
| | | 230V AC | M73 | 180267 |
| | PSS | 24V AC | EM 04 | 180301 |
| | | 230V AC | EM 05 | 180302 |
| Varistor + LED (red) | PI | 110 - 230V AC | M93G | 180276 |
| Resistor | PI | 110 - 230V AC | M103 | 180269 |

Accessories

| | for Series | Type | Art.No. |
|--------------------------|------------|----------|---------|
| Retaining Clip (plastic) | PI50 | HB/RP 16 | 180029 |
| | PSS8/3 | HB/PSS | 180060 |
| Front cover | PSS8/3 | BS/PSS | 180057 |

Relaysets

| Contacts | Nominal voltage | Socket | LED/ Varistor | protection diode | Type | Art.No. |
|----------|-----------------|--------|---------------|---------------------------------|---------------------------|---------|
| 2 CO | AC | 24V | ■ | ■ | SET RP524+LD+PSS8+HB | 100686 |
| | | 24V | ■ | ■ | SET RP024+LD/FD+PSS8+HB | 100681 |
| | AC | 230V | ■ | ■ | SET RP024+LD/FD+PI50BE+HB | 100682 |
| | | | ■ | ■ | SET RP730+LD+PSS8+HB | 100684 |
| | | ■ | ■ | SET RP730+LD/ARISTOR+PI50BE3+HB | 100688 | |

other sets on request

Switching Relays Series SKR

Interface Relays

- 1 CO contact, max. 6A switching current
- Rated coil voltage 24VAC/DC or 230V AC
- Position indicator via LED
- Width 6,2mm
- Accessories: 20-way jumper link

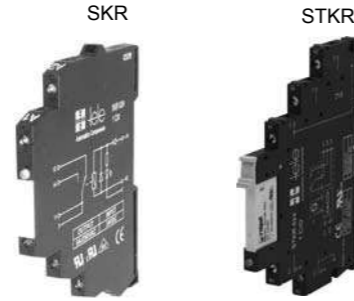

Interface relays

| Contacts | Nominal voltage | Type | Art.No. |
|--------------|-----------------|---------|---------|
| 1 CO contact | AC/DC 24V | SKR 524 | 180501 |
| | DC 24V | SKR 024 | 180500 |
| | AC 230V | SKR 730 | 180502 |

Set pluggable interface relays

| Contacts | Nominal voltage | Type | Art.No. |
|--------------|-----------------|----------|---------|
| 1 CO contact | AC/DC 24V | STKR 524 | 180504 |
| | DC 24V | STKR 024 | 180503 |
| | AC 230V | STKR 730 | 180505 |

Replacement relays

| | Nominal voltage | for Series | Type | Art.No. |
|--|-----------------|--------------------|---------------------|---------|
| | DC 24V | STKR 024, STKR 524 | RM699V-3011-85-1024 | 100660 |
| | DC 60V | STKR 730 (230V AC) | RM699V-3011-85-1060 | 100661 |

Accessories

| | for Series | Type | Art.No. |
|--|------------|----------|---------|
| Jumper link blue for 20 coupling units | SKR, STKR | PB-B SKR | 180535 |
| Jumper link red for 20 coupling units | SKR, STKR | PB-R SKR | 180536 |



Coupling units Series ENYA

Coupling relay

- Zoom voltage 24-240V AC/DC
- 1 CO or 2 CO contacts
- Width 17,5mm or 35mm
- Installation design

Type

E1K 24-240VAC/DC

E3K 12-240VAC/DC



Art.No. (PQ1)
 Art.No. (PQ10)
 EAN13-Code
 Controls
 Indicators (LEDs)
 Functions
 Isolation
 Overvoltage cat.
 Supply
 Output
 Width
 Certificates
 Mechanical design
 Terminal capacity
 Ambient conditions
 Accessories

110700

-

9008662006034

-

R

Coupling relays

Rated voltage 250V AC

III (in accordance with IEC 60664-1)
 Rated voltage: 4kV

24-240VAC/DC
 terminals A1-A2

1 potential free change over contact
 250V AC, 8A

17,5mm

CE

Self-extinguishing plastic housing, IP rating IP40 • Mounted on DIN-rail TS 35 according to EN 60715 • Mounting position: any • Shockproof terminal connection according to VBG 4 (PZ1 required), IP rating IP20 • Tightening torque: max. 1Nm

1 x 0.5 to 2.5mm² with/without multicore cable end • 1 x 4mm² without multicore cable end • 2 x 0.5 to 1.5mm² with/without multicore cable end
 2 x 2.5mm² flexible without multicore cable end

Ambient temperature: -25 to +55°C • Storage temperature: -25 to +70°C • Transport temperature: -25 to +70°C • Relative humidity: 15% to 85% (in accordance with IEC 60721-3-3 class 3K3) • Pollution degree: 2, if built in 3 (in accordance with IEC 60664-1)

-

111700

-

9008662006041

-

R

Coupling relays

Rated voltage 250V AC

III (in accordance with IEC 60664-1)
 Rated voltage: 4kV

12-240VAC/DC
 terminals A1-A2

2 potential free change over contact
 250V AC, 8A

35mm

CE



Coupling units Series OCTO

Automatic-Manual-OFF relay

- Three-way switch: Automatic, permanently OFF or ON
- Checkback signal of the switch setting AUTO
- 1 CO contact
- Width 17,5mm
- Installation design

Functions

Connections

Type

HAR1



Art.No. (PQ1)

170010

Art.No. (PQ10)

-

EAN13-Code

900866200067

Controls

Function

Indicators (LEDs)

R

Functions

AUTO (automatic) • 0 (permanently OFF) • HAND (permanently ON)

Control input

control voltage for automatic operation
24V AC/DC
terminals A3-A2

Output

1 potential free CO contact
250V AC, 8A

Checkback

1 potential free NO contact for checkback signal of the switch setting AUTO
48V AC/DC; 500mA
terminals B1-B2

Supply

24V AC/DC
terminals A1-A2

Width

17,5mm

Certificates

CE • GOST

Mechanical design

Self-extinguishing plastic housing, IP rating IP40 • Mounted on DIN-Rail TS 35 in accordance with EN 60715 • Mounting position any • Shockproof terminal connection according to VBG 4 (PZ1 required), IP rating IP20 • Tightening torque max. 1Nm

Terminal capacity

1 x 0,5 to 2,5mm² with/without multicore cable end • 1 x 4mm² without multicore cable end • 2 x 0,5 to 1,5mm² with/without multicore cable end • 2 x 2,5mm² flexible without multicore cable end

Ambient conditions

Ambient temperature: -25 to +55°C (in accordance with IEC 60068-1) • Storage temperature: -25 to +70°C • Transport temperature: -25 to +70°C • relative humidity: 15% to 85% (in accordance with IEC 60721-3-3 class 3K3) • Pollution degree: 2, if built in 3 (in accordance with IEC 60664-1)

Accessories

-

E1K

E3K

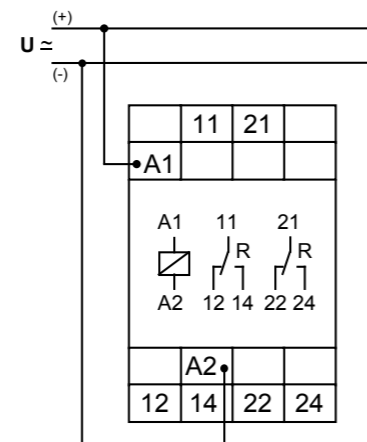
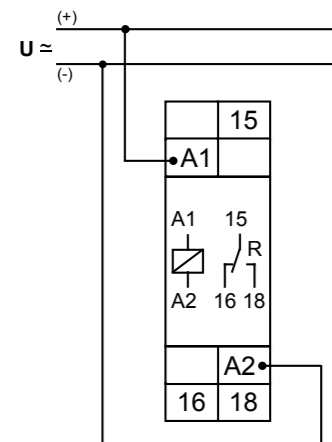

Width 17,5mm

Width 35mm

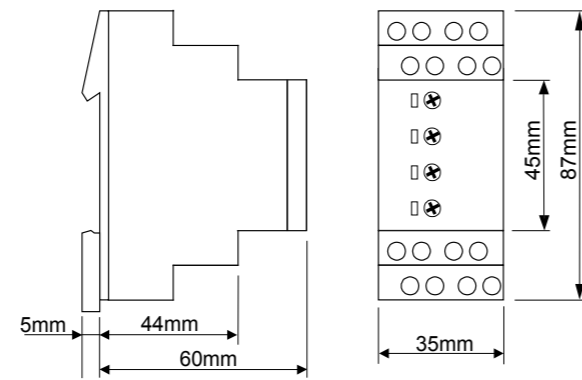
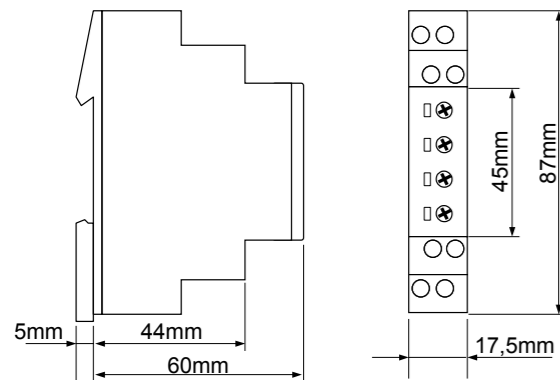

Dimensions

Automatic (AUTO)

The contact of checkback B1-B2 is closed.
When the signal voltage U is applied at terminal A3 the output relay R switches into on-position (yellow LD illuminated)

Permanently OFF (0)

The contact of checkback B1-B2 is opened.
The output relay R remains in off-position independent from the connected signal voltage.

Permanently ON (HAND)

The contact of checkback B1-B2 is opened.
When the supply voltage U is applied at terminal A1 the output relay R switches into on-position (yellow LED illuminated). Changes of the signal voltage do not influence the state of the output relay.

HAR1

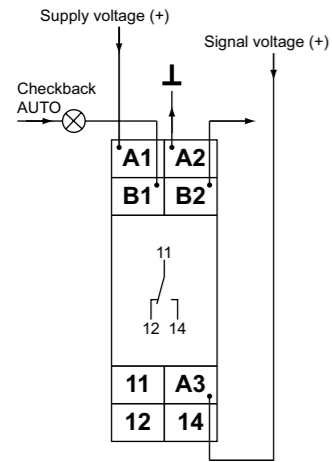

Width 17,5mm

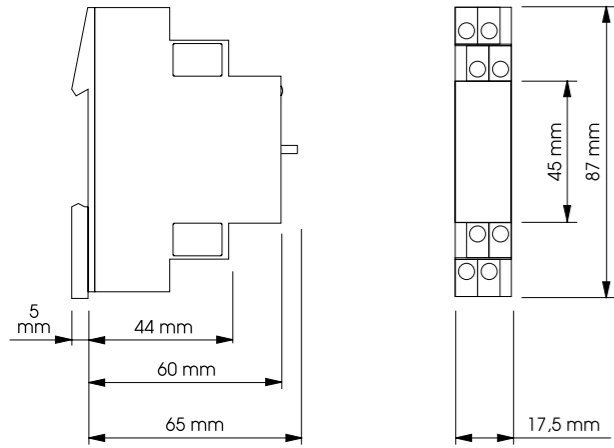

Functions

**Coupling units Series OCTO**

Analogue data encoder

- Analogue data encoder 0 to 10V DC (OVP1)
- Analogue data encoder 0 to 20mA DC (OCP1)
- Checkback signal of the switch setting AUTO
- 1 analogue output and 1 NO contact (checkback)
- Width 17,5mm
- Installation design

Connections

Type

OVP1 24VAC/DC

OCP1 24VAC/DC



Art.No. (PQ1)

170012

170018

Art.No. (PQ10)

-

-

EAN13-Code

900866200069

900866200075

Controls

function • analogue data

function • analogue data

Indicators (LEDs)

LED (intensity according to the value of the output signal)

LED (intensity according to the value of the output signal)

Functions

AUTO (output according to input YR)
0 (permanently OFF)
HAND (output according to set value (regulator))

AUTO (output according to input YR)
0 (permanently OFF)
HAND (output according to set value (regulator))

Analogue input

input for automatic operation
0 to 10V DC
terminals YR-GND

input for automatic operation
0 to 20mA DC
terminals YR-GND

Output

1 analogue output
0 to 10V DC
terminals Y-GND

1 analogue output
0 to 20mA DC
terminals Y-GND

Checkback

1 potential free NO contact for checkback signal of the switch setting
AUTO
28V AC/DC; 2A
terminals B1-B2

1 potential free NO contact for checkback signal of the switch setting
AUTO
28V AC/DC; 2A
terminals B1-B2

Supply

24V AC/DC
terminals A1-A2

24V AC/DC
terminals A1-A2

Width

17,5mm

17,5mm

Certificates

CE • GOST

CE • GOST

Mechanical design

Self-extinguishing plastic housing, IP rating IP40 • Mounted on DIN-Rail TS 35 in accordance with EN 60715 • Mounting position any • Shockproof terminal connection according to VBG 4 (PZ1 required), IP rating IP20 • Tightening torque max. 1Nm

Terminal capacity

1 x 0,5 to 2,5mm² with/without multicore cable end • 1 x 4mm² without multicore cable end • 2 x 0,5 to 1,5mm² with/without multicore cable end • 2 x 2,5mm² flexible without multicore cable end

Ambient conditions

Ambient temperature: -25 to +55°C (in accordance with IEC 60068-1) • Storage temperature: -25 to +70°C • Transport temperature: -25 to +70°C • relative humidity: 15% to 85% (in accordance with IEC 60721-3-3 class 3K3) • Pollution degree: 2, if built in 3 (in accordance with IEC 60664-1)

Accessories

-

Dimensions

OVP1

Automatic (AUTO): The contact of checkback B1-B2 is closed. The input signal applied to terminal YR is looped through unchanged to terminal Y.

Permanently OFF (0): The contact of checkback B1-B2 is opened. No output signal at terminal Y.

Manual signal (HAND): The contact of checkback B1-B2 is opened. Output signal at terminal Y (0 to 10V DC) according to the value set on the front mounted regulator.

OCP1

Automatic (AUTO): The contact of checkback B1-B2 is closed. The input signal applied to terminal YR is looped through unchanged to terminal Y.

Permanently OFF (0): The contact of checkback B1-B2 is opened. No output signal at terminal Y.

Manual signal (HAND): The contact of checkback B1-B2 is opened. Output signal at terminal Y (0 to 20mA DC) according to the value set on the front mounted regulator.

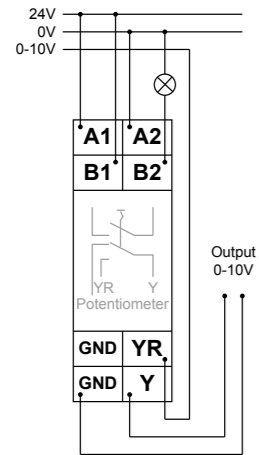
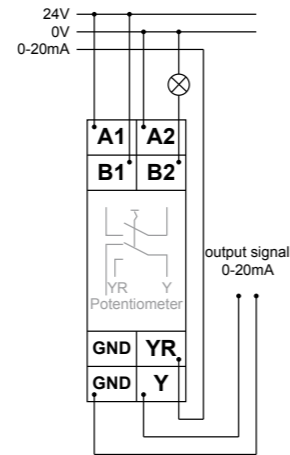
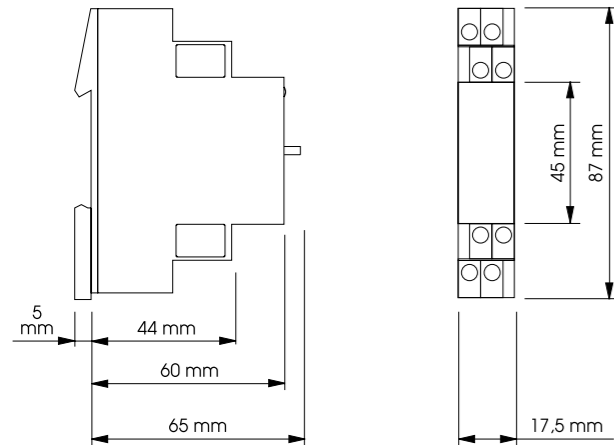
OVP1**OCP1****Width 17,5mm****Functions****Coupling units Series OCTO****Levelswitch**

- Trigger 1 to 10V DC (OVL1)
- Trigger 2 to 20mA DC (OCL1)
- Checkback signal for switch setting AUTO
- 1 CO contact
- Width 17,5mm
- Installation design

Connections**Type****OVL1 24VAC/DC****OCL1 24VAC/DC**

Art.No. (PQ1)

170015

170017

Art.No. (PQ10)

-

-

EAN13-Code

900866200072

900866200074

Controls

Function • levelswitch

Function • levelswitch

Indicators (LEDs)

U • R

U • R

Functions

AUTO (output according to signal on YR)
0 (permanently OFF)
1 (permanently ON)

AUTO (output according to signal on YR)
0 (permanently OFF)
1 (permanently ON)

Trigger level

1 to 10V DC

2 to 20mA DC

Analogue input

input for automatic operation
0 to 10V DC
terminals YR-A2

input for automatic operation
0 to 20mA DC
terminals YR-A2

Checkback

1 potential free NO contact for checkback signal of the switch setting
AUTO
28V AC/DC; 2A
terminals B1-B2

1 potential free NO contact for checkback signal of the switch setting
AUTO
28V AC/DC; 2A
terminals B1-B2

Supply

24V AC/DC
terminals A1-A2

24V AC/DC
terminals A1-A2

Output

1 potential free CO contact
250V AC, 8A

1 potential free CO contact
250V AC, 8A

Width

17,5mm

17,5mm

Certificates

CE • GOST

CE • GOST

Mechanical design

Self-extinguishing plastic housing, IP rating IP40 • Mounted on DIN-Rail TS 35 in accordance with EN 60715 • Mounting position any • Shockproof terminal connection according to VBG 4 (PZ1 required), IP rating IP20 • Tightening torque max. 1Nm

Terminal capacity

1 x 0,5 to 2,5mm² with/without multicore cable end • 1 x 4mm² without multicore cable end • 2 x 0,5 to 1,5mm² with/without multicore cable end • 2 x 2,5mm² flexible without multicore cable end

Ambient conditions

Ambient temperature: -25 to +55°C (in accordance with IEC 60068-1) • Storage temperature: -25 to +70°C • Transport temperature: -25 to +70°C • relative humidity: 15% to 85% (in accordance with IEC 60721-3-3 class 3K3) • Pollution degree: 2, if built in 3 (in accordance with IEC 60664-1)

Accessories

-

Dimensions

OVL1
Automatic (AUTO): The contact of checkback B1-B2 is closed. The output relay R switches into on-position (yellow LED illuminated) when the signal voltage applied at the terminals YR-A2 exceeds the value adjusted at the regulator. The output relay switches into off-position (yellow LED not illuminated) when the signal voltage falls below the set value by more than the fixed hysteresis.
Permanently OFF (0): The contact of checkback B1-B2 is opened. The output relay R remains in off-position (yellow LED not illuminated) independent from the connected signal voltage.
Permanently ON (HAND): The contact of checkback B1-B2 is opened. When the supply voltage U is applied at terminal A1 the output relay R switches into on-position (yellow LED illuminated). Changes of the signal voltage do not influence the state of the output relay.

OCL1
Automatic (AUTO): The contact of checkback B1-B2 is closed. The output relay R switches into on-position (yellow LED illuminated) when the signal voltage applied at the terminals YR-A2 exceeds the value adjusted at the regulator. The output relay switches into off-position (yellow LED not illuminated) when the signal voltage falls below the set value by more than the fixed hysteresis.
Permanently OFF (0): The contact of checkback B1-B2 is opened. The output relay R remains in off-position (yellow LED not illuminated) independent from the connected signal voltage.
Permanently ON (HAND): The contact of checkback B1-B2 is opened. When the supply voltage U is applied at terminal A1 the output relay R switches into on-position (yellow LED illuminated). Changes of the signal voltage do not influence the state of the output relay.

OVL1

OCL1

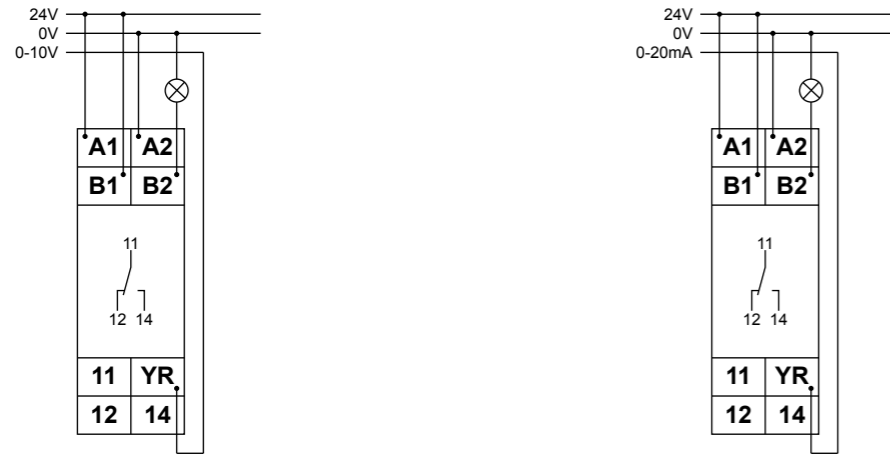

Width 17,5mm

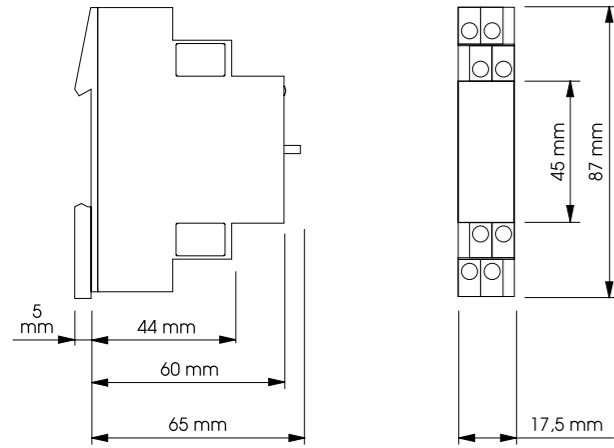

Functions



Diode gate Series TREND

Array with ,or' function

- Diode gate with 10 inputs and one output
- Combined alarm signal
- Width 22,5mm
- Plug-in mounting

Connections

Type

TD1

TD2



Art.No. (PQ1)

2490000

2490001

Art.No. (PQ10)

-

-

EAN13-Code

9008662005846

9008662005853

Controls

-

-

Indicators (LEDs)

-

-

Functions

logical function ,OR'

logical function ,OR'

Inputs

semiconductor elements: pins 2 to 11
 10 diodes (types 1N4007)
 anode is common
 peak voltage: 1000V
 forward voltage: approx. 0,8V
 forward current per diode: 0,7A (single channel)
 forward current per diode: 0,1A (all channels)

semiconductor elements: pins 2 to 11
 10 diodes (types 1N4007)
 cathode is common
 peak voltage: 1000V
 forward voltage: approx. 0,8V
 forward current per diode: 0,7A (single channel)
 forward current per diode: 0,1A (all channels)

Supply

-

-

Output

semiconductor element: pins 1
 1 diodes (types 1N4007)
 peak voltage: 1000V
 forward voltage: approx. 0,8V
 forward current: max. 1A

semiconductor element: pins 1
 1 diodes (types 1N4007)
 peak voltage: 1000V
 forward voltage: approx. 0,8V
 forward current: max. 1A

Width

22,5mm

22,5mm

Certificates

CE • GOST

CE • GOST

Mechanical design

Self-extinguishing plastic housing, IP rating IP40 • Connection and mounting by 11-pin socket in accordance with IEC 60067-1-18a (types R11X or ES12) • Mounting position any

Ambient conditions

Ambient temperature: -25 to +55°C (in accordance with IEC 60068-1) • Storage temperature: -25 to +70°C • Transport temperature: -25 to +70°C • relative humidity: 15% to 85% (in accordance with IEC 60721-3-3 class 3K3) • Pollution degree: 3 (in accordance with IEC 60664-1)

Accessories

Plug-in socket R11X or ES12

Dimensions

Diode gate with 10 inputs and one output

TD1

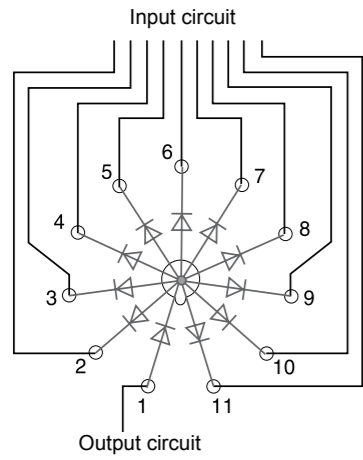

TD2

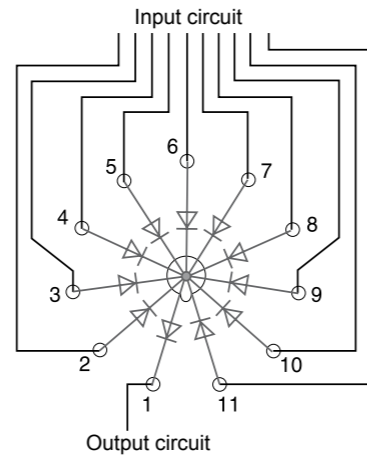

Width 22,5mm

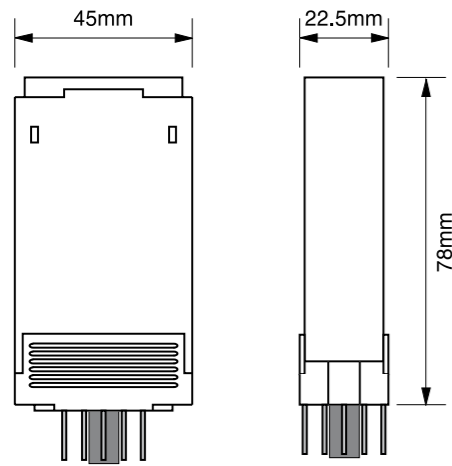

Functions



Coupling units Series VOX

Multicoupling relay

- 4-way coupling relay
- PNP (KM2X04P-M) or NPN (KM2X04M-M) control
- 2 CO contacts, 2 NO contacts
- Width 22,5mm
- Industrial design

Connections

Type

KM2X04P-M 24VDC

KM2X04M-M 24VDC



Art.No. (PQ1)

423501

423502

Art.No. (PQ10)

-

-

EAN13-Code

900866200352

900866200356

Controls

-

-

Indicators (LEDs)

R1 • R2 • R3 • R4

R1 • R2 • R3 • R4

Functions

coupling relay

coupling relay

Supply

24V DC
terminals A1-A5 (relay 1)
terminals A2-A5 (relay 2)
terminals A3-A5 (relay 3)
terminals A4-A5 (relay 4)
polarity: +24V as common on terminal A5

24V DC
terminals A1-A5 (relay 1)
terminals A2-A5 (relay 2)
terminals A3-A5 (relay 3)
terminals A4-A5 (relay 4)
polarity: GND (-) as common on terminal A5

Output

2 potential free CO contact; 250V AC, 8A
2 potential free NO contact; 250V AC, 8A

2 potential free CO contact; 250V AC, 8A
2 potential free NO contact; 250V AC, 8A

Width

22,5mm

22,5mm

Certificates

CE • GOST

CE • GOST

Mechanical design

Self-extinguishing plastic housing, IP rating IP40 • Mounted on DIN-Rail TS 35 in accordance with EN 60715 • Mounting position any • Shockproof terminal connection according to VBG 4 (PZ1 required), IP rating IP20 • Tightening torque max. 1Nm

Terminal capacity

1 x 0,5 to 2,5mm² with/without multicore cable end • 1 x 4mm² without multicore cable end • 2 x 0,5 to 1,5mm² with/without multicore cable end • 2 x 2,5mm² flexible without multicore cable end

Ambient conditions

Ambient temperature: -25 to +55°C (in accordance with IEC 60068-1) • Storage temperature: -25 to +70°C • Transport temperature: -25 to +70°C • relative humidity: 15% to 85% (in accordance with IEC 60721-3-3 class 3K3) • Pollution degree: 2, if built in 3 (in accordance with IEC 60664-1)

Accessories

-

Dimensions

Coupling relay with four independent circuits including galvanic separated output relays.

Semiconductor control KM2X04P-M

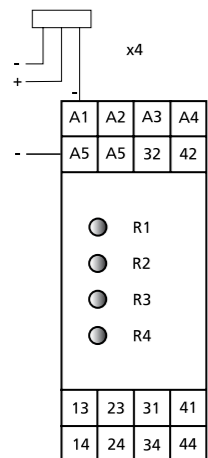

KM2X04M-M

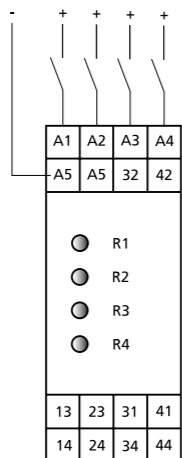

KM2X04M-M

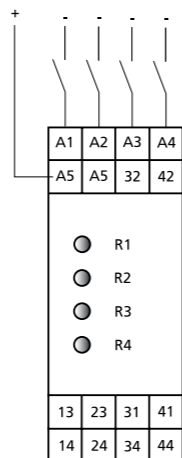

Width 22,5mm

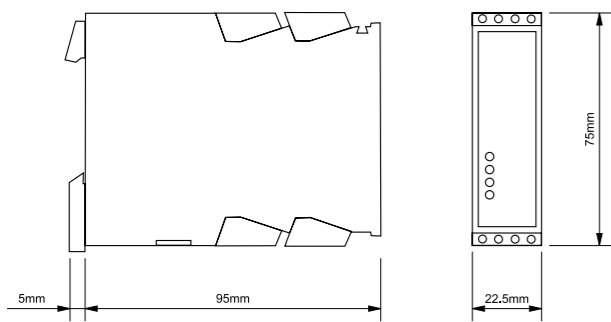

Functions



Signal converter **Series M1**

Signalamplifier

- Separation and transformation of standard signals (M1MTB1; M1MTN1)
- Uni- and bipolare industrial signals (M1MTB1)
- Temperature signal converter for temperatures from -100 to +700°C (M1MPT100)
- Applicable to PT100 and PT1000 probes
- 3-Port-separation with secure galvanic separation
- Supply voltage by zoom voltage 24 to 240V AC/DC
- 1 output
- Width 12,5mm
- Industrial design

Connections

Type

M1MTB1 24-240V

M1MTN1 24-240V

M1MPT100 24-240V



Art.No. (PQ1)

717002

717003

717004

Art.No. (PQ10)

-

-

-

EAN13-Code

-

-

-

Controls

Zero • Span

-

Zero • Span

Indicators (LEDs)

U

U

U

Functions

Universal signal amplifier

Standard signal amplifier

Universal temperature signal amplifier

Input circuit

current input terminals 1-2:
±20mA • 0 to 20mA • 4 to 20mA • ±10mA • 0 to 10mA • 2 to 10mA
(input resistance 250hm)

current input terminals 1-2:
0 to 20mA • 4 to 20mA
(input resistance 220hm)

thermo couple input terminals 1 to 4:
probe: PT100 or PT1000
2-wire, 3-wire or 4-wire
measured range: -100°C to +700°C
probe current PT100: 1mA
probe current PT1000: 0,1mA
wiring impedance per wire: max. 100hm
sensor wire brake detection: yes

voltage input terminals 3-4:
±10V • 0 to 10V • 2 to 10V • ±5V • 0 to 5V • 1 to 5V
(input resistance: approx. 1 Ohm)

voltage input terminals 3-4:
0 to 10V
(input resistance: approx. 1 Ohm)

Output circuit

current output terminals 5-6:
±20mA • 0 to 20mA • 4 to 20mA • ±10mA • 0 to 10mA • 2 to 10mA
(output voltage: max. 12V)

current output terminals 5-6:
0 to 20mA • 4 to 20mA
(output voltage: max. 10V)

current output terminals 5-6:
0 to 20mA • 4 to 20mA
(output voltage: max. 10V)

voltage output terminals 5-6:
±10V • 0 to 10V • 2 to 10V • ±5V • 0 to 5V • 1 to 5V
(output current: max. 10mA)

voltage output terminals 5-6:
0 to 10V
(output current: max. 10mA)

voltage output terminals 5-6:
0 to 10V • 2 to 10V • 0 to 5V • 1 to 5V
(output current: max. 5mA)

Isolation

3-way isolation:
secure galvanic separation up to 600V AC
(in accordance with DIN EN 61010 part 1)
overvoltage cat. II (4kV AC)

3-way isolation
overvoltage cat. II (2,5kV AC)

3-way isolation:
secure galvanic separation up to 300V AC/DC
(in accordance with DIN EN 61010 part 1)
overvoltage cat. II (2,5kV)

Supply

24 to 240V AC/DC
terminals 7-8

24 to 240V AC/DC
terminals 7-8

24 to 240V AC/DC
terminals 7-8

Width

12,5mm

12,5mm

12,5mm

Certificates

CE • GOST

CE • GOST

CE • GOST

Mechanical design

Self-extinguishing plastic housing, IP rating IP40 • Mounted on DIN-Rail TS 35 in accordance with EN 60715 • Mounting position any • Shockproof terminal connection according to VBG 4 (PZ1 required), IP rating IP20 • Tightening torque max. 1Nm

Terminal capacity

1 x 0,5 to 2,5mm² with/without multicore cable end • 1 x 4mm² without multicore cable end • 2 x 0,5 to 1,5mm² with/without multicore cable end • 2 x 2,5mm² flexible without multicore cable end

Ambient conditions

Ambient temperature: -20 to 70°C • Storage temperature: -35 to +85°C • Transport temperature: -35 to +85°C • relative humidity: 15% to 85% • Pollution degree: 2

Accessories

-

Dimensions

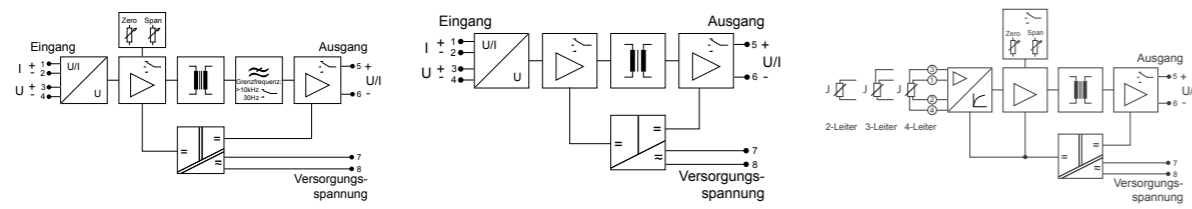

M1MTB1 24-240V

M1MPT100 24-240V

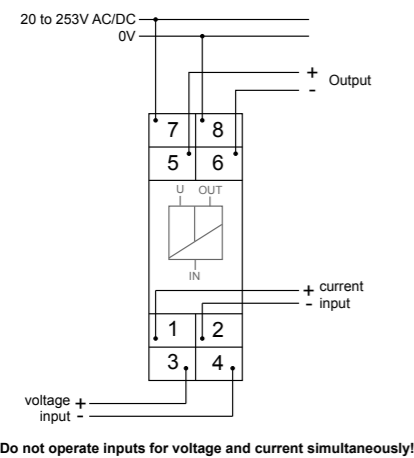

M1MTN1 24-240V with current input

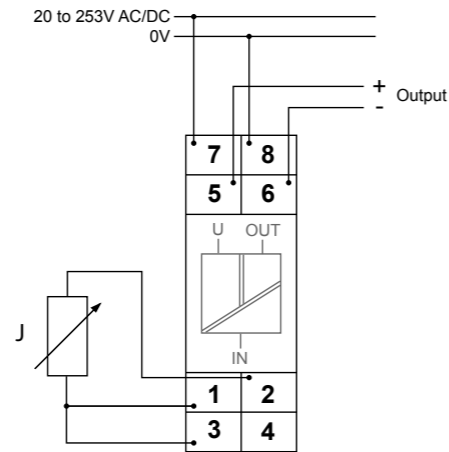

M1MTN1 24-240V with voltage input

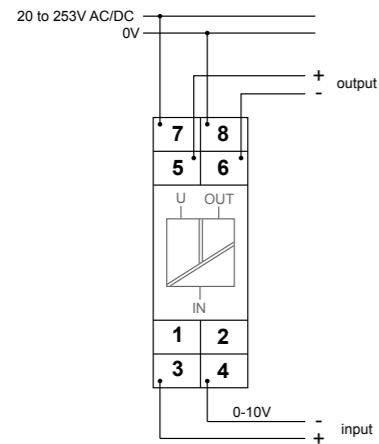

Width 12,5mm

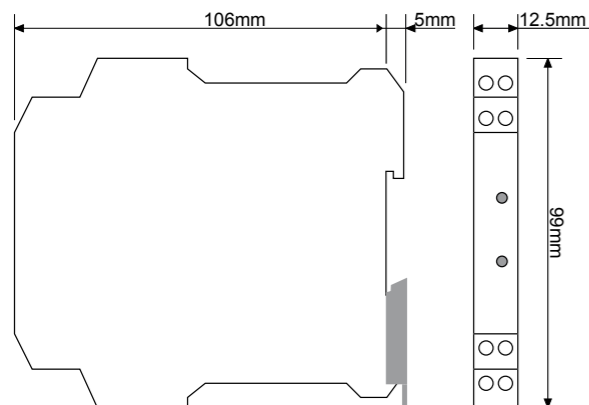
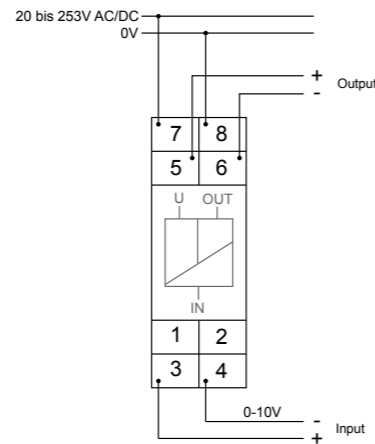

Block diagram



Signal converter **Series M1**
Loop-Powered Isolator

- Separation of 0(4)...20mA Standard Signals
- No power supply signal required
- 2-channels with secure galvanic separation; test voltage 4 kV ~
- Width 12,5mm
- Industrial design

Connections

Type

M1MTNI



717005

Art.No. (PQ1)

Art.No. (PQ10)

EAN13-Code

Controls

Indicators (LEDs)

Functions

Input circuit

Output circuit

Isolation

Supply

Width

Certificates

Mechanical design

Terminal capacity

Ambient conditions

Accessories

Connections

Dimensions

| | |
|--------------------|--|
| Art.No. (PQ1) | 717005 |
| Art.No. (PQ10) | |
| EAN13-Code | |
| Controls | - |
| Indicators (LEDs) | - |
| Functions | Loop-Powered Isolator |
| Input circuit | current input terminals 1-2, 3-4 4 to 20mA / max. 30V operating current: < 20 µA overload: ≤ 100 mA, ≤ 30V |
| Output circuit | current output terminals 5-6, 7-8 4 to 20mA / max. 28V response time: approx. 5ms at 500 Ω load ripple: < 10 mVeff |
| Isolation | working voltage: (basic insulation) up to 600V AC/DC for overvoltage category II (4kV AC), (accord. DIN EN 61010-1) |
| Supply | - |
| Width | 12,5mm |
| Certificates | CE • GOST |
| Mechanical design | Self-extinguishing plastic housing, IP rating IP40 • Mounted on DIN-Rail TS 35 in accordance with EN 60715 • Mounting position any • Shockproof terminal connection according to VBG 4 (PZ1 required), IP rating IP20 • Tightening torque max. 1Nm |
| Terminal capacity | 1 x 0,5 to 2,5mm ² with/without multicore cable end • 1 x 4mm ² without multicore cable end • 2 x 0,5 to 1,5mm ² with/without multicore cable end • 2 x 2,5mm ² flexible without multicore cable end |
| Ambient conditions | Ambient temperature: -20 to 70°C • Storage temperature: -35 to +85°C • Transport temperature: -35 to +85°C • relative humidity: 15% to 85% • Pollution degree: 2 |
| Accessories | - |

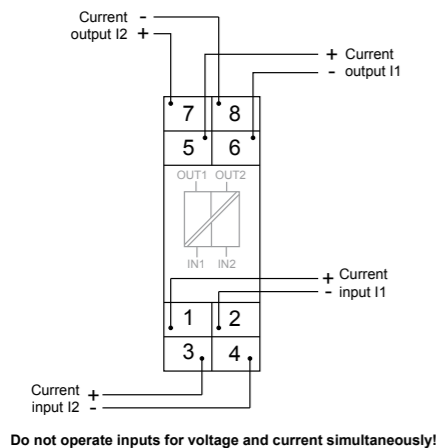
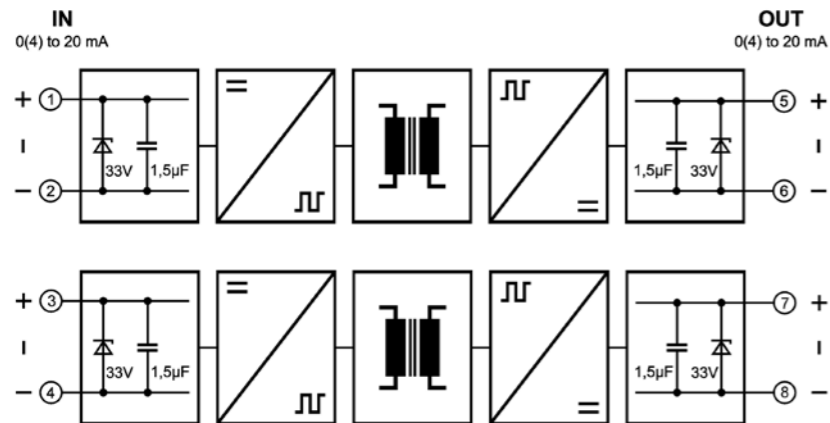

Width 12,5mm

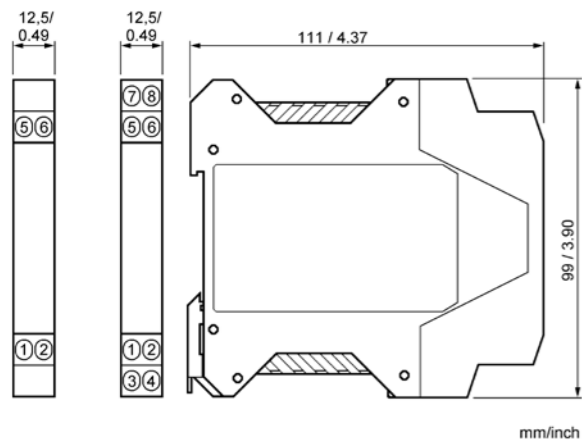

Block diagram



Mains decoupler Series OCTO

- All-pole disconnection
- Automatic operation
- Automatic off (manual on for test purpose)
- up to 1000W lamp load
- Minimised DC test voltage in switched off state (200 to 250mV)
- Width 35mm
- Installation design

Connections

Type

ONF3 230V AC



Art.No. (PQ1)

2330900

Art.No. (PQ10)

-

EAN13-Code

900866200126

Measured variable

Detection of no load condition

Adjustable range

5 to 200mA (Activation current I_{ON})
for adaption to characteristic of connected loads

Release current

fixed, approx. 70% of adjusted activation current

Test voltage

200 to 250mV DC monitoring voltage at disconnected mains

Controls

I_{ON} • Function

Indicators (LEDs)

U • R

Functions

1: Automatic operation (automated disconnected mains at no load condition)
0: manual ON for test purpose

Tripping delay

fixed, approx. 6s

Rise time

fixed, approx. 0,5s

Supply

230V AC
terminals L-N

Output

2 NO contacts
250V, 16A AC

Width

35mm

Certificates

CE • GOST

Mechanical design

Self-extinguishing plastic housing, IP rating IP40 • Mounted on DIN-Rail TS 35 in accordance with EN 60715 • Mounting position any • Shockproof terminal connection according to VBG 4 (PZ1 required), IP rating IP20 • Tightening torque max. 1Nm

Terminal capacity

1 x 0,5 to 2,5mm² with/without multicore cable end • 1 x 4mm² without multicore cable end • 2 x 0,5 to 1,5mm² with/without multicore cable end • 2 x 2,5mm² flexible without multicore cable end

Ambient conditions

Ambient temperature: -25 to 55°C (in accordance with IEC 60068-1) • Storage temperature: -25 to +70°C • Transport temperature: -25 to +70°C • relative humidity: 15% to 85% (in accordance with IEC 60721-3-3 class 3K3) • Pollution degree: 2, if built in 3 (in accordance with IEC 60664-1)

Accessories

Ballast GLE-ONF

Dimensions

- 0 Automatic OFF
- 1 Automatic ON

ONF3

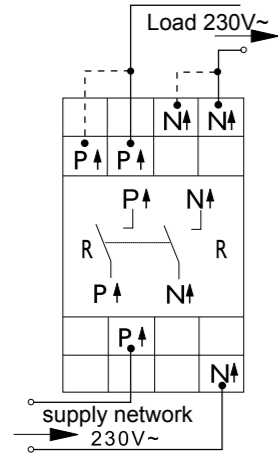

Width 35mm

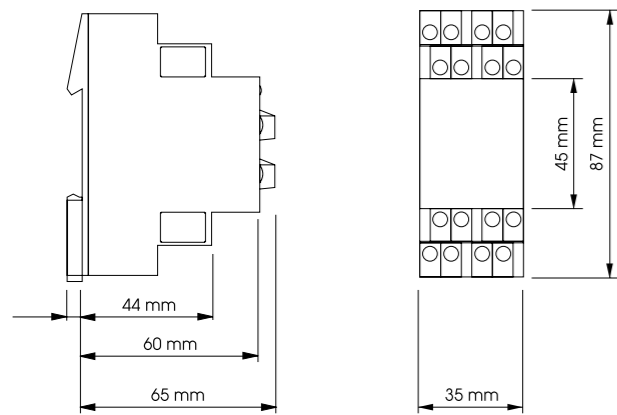

Functions



Safety relays Series S²

Modul system

- Monitoring of emergency OFF and two-handed equipment
- Monitoring of protective doors, light barriers and photoelectric beams
- One- or two-channel control
- Contact extensions, delayed or instantaneous switching
- Stop categorie 0 or 1
- Width 22,5mm

Connections

Dimensions

| | | Safety relays | | | | | | | | | | Emergency OFF relay | |
|-----------------------|--|-------------------|--------------------|-------------------|--------------------|--------------------|------------------|-------------------|------------------|-------------------|----------------|---------------------|---|
| Supply voltage | 24V AC | ■ | ■ | ■ | ■ | ■ | ■ | ■ | ■ | ■ | ■ | | |
| | 24V DC | ■ | ■ | ■ | ■ | ■ | ■ | ■ | ■ | ■ | ■ | | |
| | 115 - 120V AC | a.A. | | | | a.A. | a.A. | a.A. | | | | | |
| | 230V AC | a.A. | | | | a.A. | a.A. | a.A. | | | | ■ | |
| Applications | Maximum Achievable Safety-Category | 4 | 4 | 4 | 4/3 | 4 | 4 | 2 | 4 | 4 | 4 | 4 | |
| | Stop-Category | 0 | 0 | 0 | 0/1 | 0 | 0 | 0 | 0 | 1 | 0 | 0 | |
| | Emergency Stop | ■ | ■ | ■ | ■ | ■ | | ■ | | | ■ | ■ | |
| | Safety Gate | ■ | ■ | ■ | ■ | | | ■ | | | ■ | ■ | |
| | Safety Mat | | | ■ | | | | | | | | | |
| | OSSD (light grill) | | | ■ | ■ | ■ | | | | | | | |
| | Monitoring of Valve-State | ■ | | | | | | | | | | | |
| | Two-Channel Activation | | | | | | | ■ | | | | | |
| | Contact Expansion Without Delay | | | | | | | | | ■ | | | |
| | Contact Expansion With Delay | | | | | | | | | | ■ | | |
| Reset | Automatic Start | ■ | ■ | ■ | ■ | ■ | ■ | ■ | | | | | |
| | Start with Reset Monitoring | ■ | ■ | ■ | ■ | ■ | | ■ | | | | | |
| | Start without Reset Monitoring | ■ | ■ | ■ | ■ | ■ | | ■ | | | | | |
| Input Circuit | Synchronous Time Check Selectable | ■ | | ■ | ■ | ■ | ■ | | | | | | |
| | Cross Monitoring | ■ | ■ | ■ | ■ | ■ | ■ | | | | | | |
| | Actuation via Semic. Output (OSSD) poss. | ■ | ■ | ■ | ■ | ■ | | | | | | ■ | ■ |
| Output Circuit | Delayed Enabling Current Path | 0 | 0 | 0 | 1 | 0 | 0 | 0 | 0 | 4 | 0 | 0 | |
| | Enabling current Path without Delay | 3 | 2 | 2 | 2 | 3 | 2 | 3 | 4 | 0 | 3 | 3 | |
| | Signalling current Paths | 0 | 1 | 1 | 0 | 0 | 1 | 1 | 3 | 3 | 1 | 1 | |
| | Delayed reset | | | | ■ | | | | | | | | |
| Width | 22,5mm | ■ | ■ | ■ | ■ | ■ | ■ | ■ | ■ | ■ | ■ | | |
| | 45mm | | | | | | | | | | | ■ | ■ |
| Type | | | | | | | | | | | | | |
| | | | | | | | | | | | | | |
| | | | | | | | | | | | | | |
| | | | | | | | | | | | | | |
| | | | | | | | | | | | | | |
| | | | | | | | | | | | | | |
| | | | | | | | | | | | | | |
| | | | | | | | | | | | | | |
| | | | | | | | | | | | | | |
| | | | | | | | | | | | | | |
| | | | | | | | | | | | | | |
| Art.No. | | 588826 | 588815 | 588814 | 588816 | 588823 | 588818 | 588811 | 588821 | 588822 | 588000 | 588033 | |
| | | S2NT030 24V AC/DC | S2NGS021 24V AC/DC | S2NG021 24V AC/DC | S2NGR120 3S 24V DC | S2LST030 24V AC/DC | S2Z021 24V AC/DC | S2NT031 24V AC/DC | S2K043 24V AC/DC | S2KR403 3S 24V DC | ZK31X45 24V DC | ZK31X45 230V AC | |

Serie S²



Serie ZK



Time Switches Series TSC

- Daily-, weekly- or yearly program
- Automatic summertime change over
- Astro function (TSC28.23)
- Unrestricted block-programming
- Up to 4 CO contacts
- DIN rail mounting and front panel mounting

DIN rail mounting

| Mains voltage | Channels | CO | Contacts NO | Astro function | Switching capacity | Rated consumption | Dimension H x B x T [mm] | Type | Art.No. |
|---------------|----------|----|-------------|----------------|--------------------|-------------------|--------------------------|---------------------|---------|
| AC 230V | 1 | 1 | | | 4000VA | 1,5VA | 90 x 35,8 x 60 | TSC28.11 pro 230VAC | 711142 |
| | 1 | | 1 | | 4000VA | 1,5VA | 90 x 35,8 x 60 | TSC18.10 pro 230VAC | 711144 |
| 230V | 2 | 2 | | | 4000VA | 1,5VA | 90 x 35,8 x 60 | TSC28.21 pro 230VAC | 711143 |
| | 2 | 2 | | ■ | 4000VA | 1,5VA | 90 x 35,8 x 60 | TSC28.23 pro 230VAC | 711147 |
| | 2 | 2 | | | 2500VA | 2VA | 120 x 71,5 x 60 | TSC98.20 pro 230VAC | 711132 |
| 230V | 4 | 3 | 1 | | 2500VA | 2VA | 120 x 71,5 x 60 | TSC98.40 pro 230VAC | 711131 |

Front panel mounting

| Mains voltage | Channels | CO | Outputs NO | Astro function | Switching capacity | Rated consumption | Dimension H x B x T [mm] | Type | Art.No. |
|---------------|----------|----|------------|----------------|--------------------|-------------------|--------------------------|-----------------|---------|
| AC 24V | 1 | 1 | | | 4000VA | 0,9VA | 94,5 x 72 x 53 | TSC44.12 24VAC | 711676 |
| | 1 | 1 | | | 4000VA | 2,8VA | 94,5 x 72 x 53 | TSC44.12 115VAC | 711576 |
| 230V | 1 | 1 | | | 4000VA | 1,5VA | 94,5 x 72 x 53 | TSC44.12 230VAC | 711578 |
| 24V | 2 | 1 | 1 | | 4000VA | 1,3VA | 94,5 x 72 x 53 | TSC44.22 24VAC | 711679 |
| 230V | 2 | 1 | 1 | | 4000VA | 1,5VA | 94,5 x 72 x 53 | TSC44.22 230VAC | 711579 |

TSC28



TSC44



TSC98



Hour Meters Series TBG and TBW

DIN rail mounting and front panel mounting

- AC powered devices synchronised by mains frequency or quartz stabilized
- DC powered devices quartz stabilised
- Capacity up to max. 999.999h
- Indication of operation mechanical or by flashing LED
- DIN rail mounting or front panel mounting

Hour meters

| Series | Rated frequency | Supply voltage | Counting capacity | Accuracy of reading | Dimension H x B x T [mm] | Type | Art.No. | |
|--------|-----------------|----------------|-------------------|---------------------|--------------------------|-------------------------|-------------------------|--------|
| TBG | | DC 12 - 48V | 999 999h | 0,1h | 28,2 x 53,2 x 63 | TBG30.18 12-48VDC | 711056 | |
| | | | | | 48 x 48 x 38 | TBG40.17 12-48VDC | 711025 | |
| | | | 99 999h | 0,1h | 85 x 17,5 x 61,5 | TBG70.18 12-48VDC | 711435 | |
| | | | | | 90 x 35 x 60 | TBG70.29 12-48VDC | 711408 | |
| TBW | 50Hz | AC | 24V | 99 999h | 0,01h | 45 x 48 x 38 | TBW40.18 24VAC 50Hz | 711045 |
| | | | | | | 45 x 48 x 38 | TBW40.18 115VAC 50Hz | 711042 |
| | | | 115V | 99 999h | 0,01h | 45 x 48 x 38 | TBW70.18 115VAC 50Hz | 711434 |
| | | | | | | 28,2 x 53,2 x 63 | TBW30.18 230VAC 50Hz | 711050 |
| | | | | | | 45 x 48 x 38 | TBW40.18 230VAC 50Hz | 711040 |
| | 50/60Hz | AC | 230V | 99 999h | 0,01h | 45 x 48 x 38 | TBW70.18 230VAC 50Hz | 711430 |
| | | | | | | 90 x 35 x 60 | TBW70.29 24VAC 50/60Hz | 711355 |
| | | | | | | 105 x 35 x 60 | TBW70.89 48VAC 50/60Hz | 711139 |
| | | | | | | 105 x 35 x 60 | TBW70.89 115VAC 50/60Hz | 711140 |
| | | | | | | 105 x 35 x 60 | TBW70.89 230VAC 50/60Hz | 711141 |
| | | | | | 90 x 35 x 60 | TBW70.29 230VAC 50/60Hz | 711350 | |

Accessories

| | Type | Art.No. |
|--|-------------|---------|
| Tension bracket for TBG/TBW30 | SB-TBX30 | 711809 |
| Shutter for TBG/TBW40 (55x55mm) | B55-TBX40 | 711800 |
| Screen for TBG/TBW40 (72x72mm) | ME72-TBX40 | 711801 |
| Retaining clip for TBG/TBW40 | SB-TBX40 | 711807 |
| Sealing ring for TBW40 (IP54) | DR-TBW40 | 711813 |
| Terminal cover for TBG/TBW70.29 (sealable) | KA-TBX70.29 | 711812 |

TBG/TBW 30.x



TBG/TBW 40.x



TBG/TBW 70.18



TBG/TBW 70.29
TBW 70.89



DC Power Supplies Series RNG and RNG-I

Transformers

- Low residual ripple
- Integrated thermo protection
- Self cooling
- Sealed-in



Power supply

| | Contacts | Primary voltage | | Secondary | | Power loss | Dimension H x B x T [mm] | Weight | Type | Art.No. | |
|-------------|----------|-----------------|------|-----------|-----------|------------|--------------------------|-----------------|-------------|---------------|--------|
| | | U | | I | P | | | | | | |
| unregulated | 1 | AC | 230V | DC | 24V | 1,5A 36VA | 18W | 120 x 78 x 96 | 1,6kg | RNG 36/12-230 | 490508 |
| | | | | | | 3A 72VA | 20W | 133 x 85 x 105 | 2,1kg | RNG 72-230 | 490510 |
| | 2 | AC | 230V | DC | 24V | 5A 120VA | 28W | 133 x 85 x 105 | 2,9kg | RNG 120-230 | 490515 |
| | | | | | | 10A 240VA | 48W | 172 x 170 x 109 | 6,1kg | RNG 240-230 | 490520 |
| | | | | | | 3A 72VA | 20W | 133 x 85 x 105 | 2,1kg | RNG 72-400 | 490511 |
| | | | | | | 5A 120VA | 28W | 133 x 85 x 105 | 2,9kg | RNG 120-400 | 490516 |
| | | 400V | DC | 24V | 10A 240VA | 48W | 172 x 170 x 109 | 6,1kg | RNG 240-400 | 490519 | |
| U-limited | 1 | AC | 230V | DC | 24V | 1,5A 36VA | 16W | 120 x 78 x 96 | 1,6kg | RNG 36-230 | 490505 |
| | | | 400V | DC | 24V | 1,5A 36VA | 16W | 120 x 78 x 96 | 1,6kg | RNG 36-400 | 490506 |

Accessories

| | Dimension H x B [mm] | Type | Art.No. |
|---------------------------|----------------------|------------|---------|
| Mounting clip for RNG 36 | 120 x 66 | MP-RNG 36 | 490593 |
| Mounting clip for RNG 72 | 132 x 70 | MP-RNG 72 | 490594 |
| Mounting clip for RNG 120 | 132 x 83 | MP-RNG 120 | 490592 |



DC power supply TELE VIP

Switching power supply

- DIN rail mounting
- Overload and short circuit protection
- Industrial housing for the switching cabinet and plant construction
- Valued Industrial Partner, China



Regulated power supply unit

| | U | Secondary | | | η [%] | Primary voltage | Dimension H x B x T [mm] | Type | Art.No. |
|---------|----|-----------|------|-------|-------|-------------------------------|--------------------------|-----------------|-----------|
| | | P | I | | | | | | |
| 1-phase | DC | 5V | 5W | 1A | 69 | 90 - 265V AC 120 - 375V DC | 90 x 22,5 x 115 | DRA05-05A | 491410 |
| | | | 10W | 2A | 73 | | 90 x 22,5 x 115 | DRA10-05A | 491411 |
| | | | 15W | 3A | 75 | | 90 x 22,5 x 115 | DRA18-05A | 491412 |
| | | | 30W | 6A | 77 | | 90 x 40,5 x 115 | DRAN30-05A | 491576 |
| | | | 60W | 10A | 79 | | 90 x 40,5 x 115 | DRAN60-05A | 491413 |
| | | | 12V | 5W | 0,4A | | 72 | 90 x 22,5 x 115 | DRA05-12A |
| | | | 10W | 0,8A | 75 | | 90 x 22,5 x 115 | DRA10-12A | 491419 |
| | | | 18W | 1,5A | 77 | | 90 x 22,5 x 115 | DRA18-12A | 491422 |
| | | | 30W | 2,5A | 82 | | 90 x 40,5 x 115 | DRAN30-12A | 491572 |
| | | | 60W | 5A | 84 | | 90 x 40,5 x 115 | DRAN60-12A | 491587 |
| | | | 120W | 10A | 84 | | 124,5 x 64 x 123,6 | DRAN120-12A | 491568 |
| | | 15V | 5W | 0,3A | 72 | | 90 x 22,5 x 115 | DRA05-15A | 491415 |
| | | | 10W | 0,7A | 76 | | 90 x 22,5 x 115 | DRA10-15A | 491414 |
| | | | 18W | 1,2A | 77 | | 90 x 22,5 x 115 | DRA18-15A | 491416 |
| | | 24V | 5W | 0,2A | 72 | | 90 x 22,5 x 115 | DRA05-24A | 491420 |
| | | | 10W | 0,4A | 76 | | 90 x 22,5 x 115 | DRA10-24A | 491424 |
| | | | 18W | 0,8A | 77 | | 90 x 22,5 x 115 | DRA18-24A | 491425 |
| | | | 30W | 1,25A | 83 | | 90 x 40,5 x 115 | DRAN30-24A | 491476 |
| | | | 60W | 2,5A | 86 | | 90 x 40,5 x 115 | DRAN60-24A | 491575 |
| | | | 120W | 5A | 86 | | 124,5 x 64 x 123,6 | DRAN120-24A | 491595 |
| | | | 240W | 10A | 89 | | 124,5 x 83,5 x 123,6 | DRA240-24A | 491571 |
| | | | 480W | 20A | 89 | | 124,5 x 175,5 x 123,6 | DRA480-24A | 491577 |

Power supply unit with total discharge protection for back-up system (e.g. storage batteries)

| | U | Secondary | | | η [%] | Primary voltage | Dimension H x B x T [mm] | Type | Art.No. |
|---------|----|-----------|-------|------|-------|-------------------------------|--------------------------|--------------|----------|
| | | I | P | | | | | | |
| 1-phase | DC | 27,2V | 1,1A | 30W | 86 | 90 - 264V AC 120 - 375V DC | 90 x 40,5 x 115 | DRAN30-24A* | 491476BU |
| | | | 2,2A | 60W | 89 | | 90 x 40,5 x 115 | DRAN60-24A* | 491575BU |
| | | | 4,4A | 120W | 86 | | 124,5 x 64 x 123,6 | DRAN120-24A* | 491569BU |
| | | | 8,8A | 240W | 90 | | 124,5 x 83,5 x 123,6 | DRAN240-24A* | 491571BU |
| | | | 17,6A | 480W | 90 | | 124,5 x 175,5 x 123,6 | DRAN480-24A* | 491577BU |

A



B



DC power supply TELE VIP

Switching power supply

- DIN rail mounting
- Overload and short circuit protection
- Industrial housing for the switching cabinet and plant construction
- Installation design for distribution and plant construction
- Valued Industrial Partner, Meanwell



ACCESSORIES

Regulated power supply unit

| | U | Secondary | | | Primary voltage | Dimension H x B x T [mm] | Type | Art.No. | |
|---------|----|-----------|---------|-------|-----------------|--------------------------------|------------------------|--------------------------|--------------------------------|
| | | P | I | η [%] | | | | | |
| 1-phase | DC | 12V | 24W | 2A | 81 | 90 - 264V AC 120 - 370V DC | 93 x 78 x 56 | DR-30-12 ¹⁾ | 491620 |
| | | | 42W | 3,5A | 77 | | 93 x 78 x 67 | DR-4512 | 491607 |
| | | | 54W | 4,5A | 82 | | 93 x 78 x 56 | DR-60-12 ¹⁾ | 491622 |
| | | | 75W | 6,3A | 76 | | 125,2 x 55,5 x 100 | DR-75-12 | 491608 |
| | | | 120W | 10A | 80 | | 125,2 x 65,5 x 100 | DR-120-12 | 491602 |
| | | | 15V | 42W | 2,8A | | 77 | 93 x 78 x 67 | DR-4515 |
| | | 24V | 36W | 1,5A | 83 | 93 x 78 x 56 | DR-30-24 ¹⁾ | 491623 | |
| | | | 48W | 2A | 80 | 93 x 78 x 67 | DR-4524 | 491611 | |
| | | | 60W | 2,5A | 84 | 93 x 78 x 56 | DR-60-24 ¹⁾ | 491621 | |
| | | | 75W | 3,2A | 81 | 125,2 x 55,5 x 100 | DR-75-24 | 491612 | |
| | | | 120W | 5A | 84 | 90 - 264V AC 248 - 370V DC | 125,2 x 65,5 x 100 | DR-120-24 | 491603 |
| | | | 240W | 10A | 84 | 85 - 264V AC 120 - 370V DC | 125 x 175 x 123 | DRP-240-24 ²⁾ | 491605 |
| | | | 480W | 20A | 89 | 180 - 264V AC 250 - 370V DC | 125,2 x 227 x 100 | DRP-480-24 ²⁾ | 491606 |
| | | | 2-phase | DC | 24V | 120W | 5A | 85 | 340 - 550V AC 480 - 780V DC |
| 3-phase | DC | 24V | 240W | 10A | 89 | 340 - 550V AC 480 - 780V DC | 125,2 x 125,5 x 100 | DRT-240-24 | 491590 |
| | | | 480W | 20A | 89 | | 125,2 x 227 x 100 | DRT-480-24 | 491613 |
| | | 24V | 960W | 40A | 91 | | 125,2 x 276 x 100 | DRT-960-24 | 491614 |
| | | 48V | 240W | 5A | 89 | | 125,2 x 125,5 x 100 | DRT-240-48 | 491615 |
| | | | 480W | 10A | 90 | | 125,2 x 227 x 100 | DRT-480-48 | 491616 |

1) Installation design
2) Power Factor Correction

Industrial design

Installation design



Power Modules, Power Supply

Power Modules: TR2 and TR3
Power Supply: SNT

Page

250
250

Level sensor

Level sensor: SK

251

Current transformers

Baffle-type current transformer: WSW
Bar-type current transformer: DSW

252
252

Others

- Base load component: GLE
- Mounting clip: MP
- Protection cover: GAMMA
- Remote potentiometer: RONDO

253
253
253
253

Power Modules - Series TR and Power Supply - Series SNT

- Plug-in module for internal power supply
- For monitoring relays, load monitors and timers (series GAMMA, TREND)
- Mounting by plug-in system in prepared slot of compatible units (no tools required)
- Powermodules, providing galvanic separation between input and output circuit
- Sealed self-extinguishing plastic housing. IP-rating IP40 (if mounted)

PowerModule

| Series | Wattage | Mains voltage | Type | Art.No. | | |
|---------|---------|---------------|---------|--------------|---------------|--------------|
| TR2 | 2VA | AC | 12V | TR2 - 12V AC | 282121 | |
| | | | 50/60Hz | 24V | TR2 - 24V AC | 282110 |
| | | | | 42V | TR2 - 42V AC | 282111 |
| | | | | 48V | TR2 - 48V AC | 282112 |
| | | | | 110V | TR2 - 110V AC | 282113 |
| | | | | 127V | TR2 - 127V AC | 282114 |
| | | | | 230V | TR2 - 230V AC | 282120 |
| | | | | 400V | TR2 - 400V AC | 282117 |
| | | | | 440V | TR2 - 440V AC | 282119 |
| | | TR3 | 4VA | AC | 12V | TR3 - 12V AC |
| 50/60Hz | 24V | | | | TR3 - 24V AC | 285010 |
| | | | | 42V | TR3 - 42V AC | 285011 |
| | | | | 48V | TR3 - 48V AC | 285012 |
| | | | | 110V | TR3 - 110V AC | 285013 |
| | | | | 230V | TR3 - 230V AC | 285025 |
| | | | | 400V | TR3 - 400V AC | 285017 |
| | | | | 440V | TR3 - 440V AC | 285019 |
| | | | | 500V | TR3 - 500V AC | 285026 |

Switching power supply

| Series | Supply voltage | Type | Art.No. |
|--------|----------------|-------------|---------|
| SNT | DC 24V | SNT2 24V DC | 282050 |

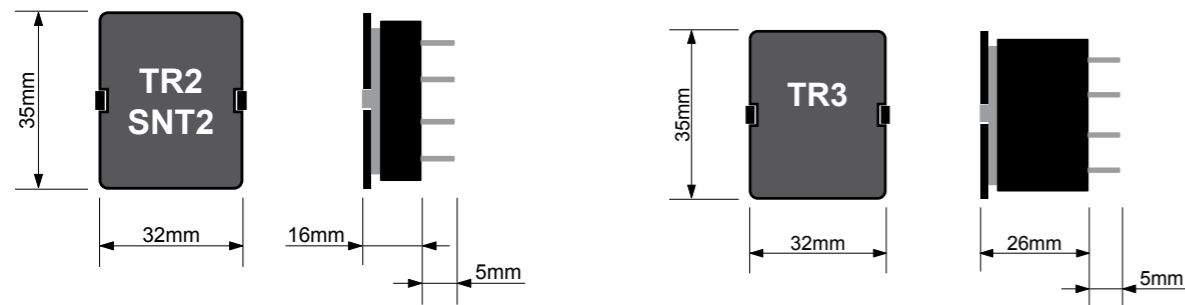

Level sensors Series SK

- Probe for monitoring level of conductive liquids
- Stainless levelprobes, PVC covered, IP rating IP44

Level sensor

| | Number of electrodes | Length | Max.Temp. | Type | Art.No. |
|--|----------------------|---------|-----------|----------|---------|
| Suspensible sensor (Immersion electrode) | | on site | 60° | SK1 | 190107 |
| Wand sensor | 2 | 500mm | 90° | SK2 | 190108 |
| | 3 | 500mm | 90° | SK3-500 | 190109 |
| | 3 | 1000mm | 90° | SK3-1000 | 190110 |

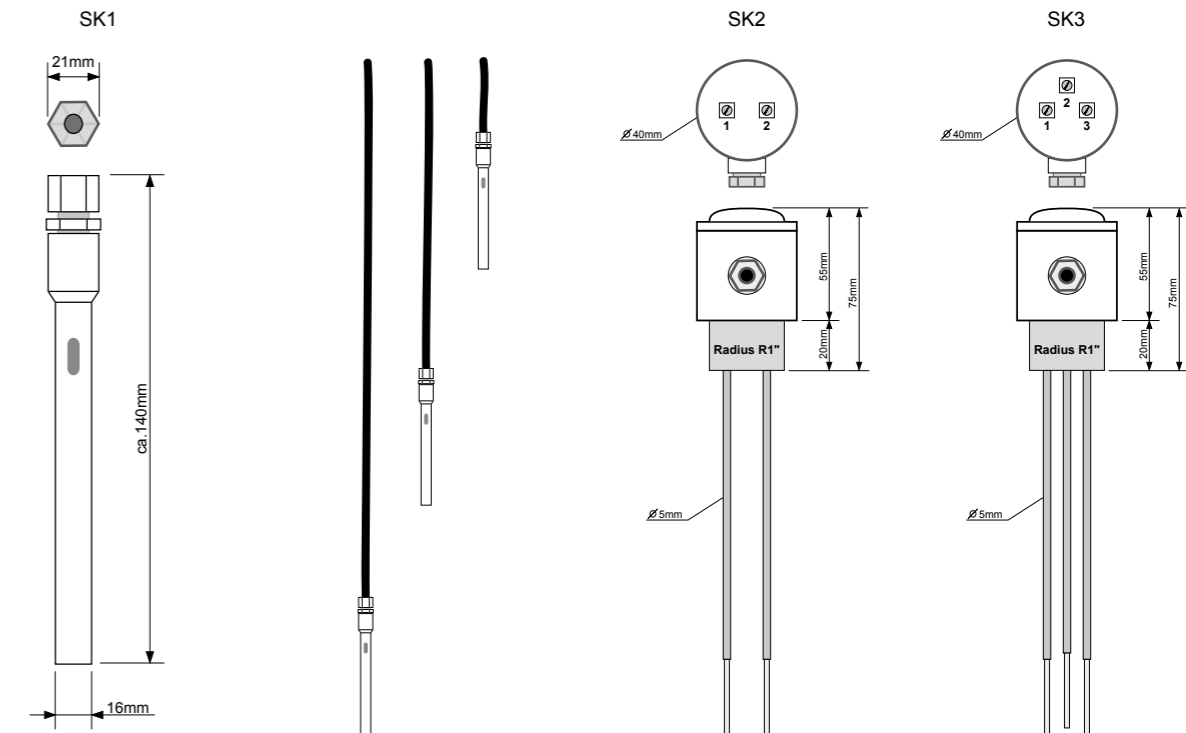

Current Transformers Series WSW and DSW

Baffle-type and bar-type current transformers

- Baffle-type current transformer (WSW 60)
- Bar-type current transformers (DSW 60 and DSW 80)
- Integrated sealable terminal covers
- DIN rail mounting clip optional



Baffle-type current transformers

| | Rated power | Primary rated current | Dimension H x B x T [mm] | Type | Art.No. |
|---------|-------------|-----------------------|-----------------------------|----------------------|---------|
| Class 1 | 2,5VA | 1A | 80 x 60 x 30 | WSW 60 1A/5A 2,5VA | 498060 |
| | | 2,5A | 80 x 60 x 30 | WSW 60 2,5A/5A 2,5VA | 498061 |
| | | 5A | 80 x 60 x 30 | WSW 60 5A/5A 2,5VA | 498062 |
| | | 10A | 80 x 60 x 30 | WSW 60 10A/5A 2,5VA | 498063 |
| | | 15A | 80 x 60 x 30 | WSW 60 15A/5A 2,5VA | 498064 |
| | | 20A | 80 x 60 x 30 | WSW 60 20A/5A 2,5VA | 498065 |
| | | 25A | 80 x 60 x 30 | WSW 60 25A/5A 2,5VA | 498066 |
| | | 30A | 80 x 60 x 30 | WSW 60 30A/5A 2,5VA | 498067 |
| | | 40A | 80 x 60 x 30 | WSW 60 40A/5A 2,5VA | 498068 |

Bar-type current transformer

| | Rated power | Primary rated current | Dimension H x B x T [mm] | Type | Art.No. |
|---------|-------------|-----------------------|-----------------------------|-----------------------|----------------------|
| Class 1 | 1,25VA | 60A | 33 x 33 x 50 | DSW 60 60A/5A 1,25VA | 498070 |
| | | 2,5VA | 100A | 33 x 33 x 50 | DSW 60 100A/5A 2,5VA |
| | 3,75VA | 125A | 33 x 33 x 50 | DSW 60 125A/5A 2,5VA | 498074 |
| | | 150A | 33 x 33 x 50 | DSW 60 150A/5A 3,75VA | 498075 |
| | 5VA | 200A | 33 x 33 x 50 | DSW 60 200A/5A 5VA | 498076 |
| | | 250A | 33 x 33 x 50 | DSW 60 250A/5A 5VA | 498077 |
| | 10VA | 300A | 33 x 33 x 50 | DSW 60 300A/5A 5VA | 498078 |
| | | 400A | 50,5 x 50,5 x 85 | DSW 80 400A/5A | 498081 |
| | | 500A | 50,5 x 50,5 x 85 | DSW 80 500A/5A | 498085 |
| | | 600A | 50,5 x 50,5 x 85 | DSW 80 600A/5A | 498082 |
| | | 750A | 50,5 x 50,5 x 85 | DSW 80 750A/5A | 498080 |
| | | 800A | 50,5 x 50,5 x 85 | DSW 80 800A/5A | 498084 |
| | | 1000A | 50,5 x 50,5 x 85 | DSW 80 1000A/5A | 498079 |
| | | 1250A | 50,5 x 50,5 x 85 | DSW 80 1250A/5A | 498083 |
| Class 3 | 1,25VA | 50A | 50,5 x 50,5 x 85 | DSW 60 50A/5A 1,25VA | 498069 |
| | | 2,5VA | 75A | 50,5 x 50,5 x 85 | DSW 60 75A/5A 2,5VA |
| | 80A | 50,5 x 50,5 x 85 | DSW 60 80A/5A 2,5VA | 498072 | |

Accessories

| | Type | Art.No. |
|---|-----------------|---------|
| Mounting clip (2 piece) for DSW and WSW | MC-SW (2 piece) | 498100 |

Accessories

Base load component GLE • Mounting clip • Protection cover • Remote potentiometer

Base load component GLE

Function

Base load element for TELE mains decoupler. The base load element is connected in parallel to electronic loads to ensure that the mains decoupler can detect the switching on of the depending circuit. After the decoupler has reconnected the circuit to the supplying power network, the base load element warms up and changes from low-impedance to high-impedance (PTC-resistor).

Mechanical design

Silicone covered PTC-resistor with connection wires for built-in applications.

Ambient conditions

Ambient temperature: -25 to +55°C • Storage temperature: -25 to +70°C • Transport temperature: -25 to +70°C • relative humidity: 15% to 85%

Montage

The base load element has to be connected in parallel to the load.

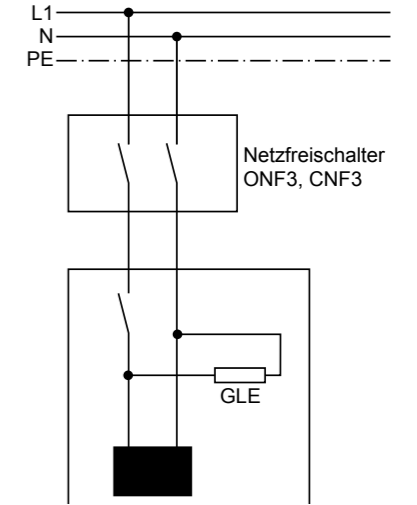

Mounting clip MP

Function

Mounting plate for fixing TELE devices on a mounting plate or wall.

Mechanical design

Self-extinguishing plastic, three drillholes diameter 4mm.

| | | |
|----------|----------------------------|----------------|
| MP | Mounting clip | Art.No. 075474 |
| MP Gamma | Mounting clip Series Gamma | Art.No. 075574 |

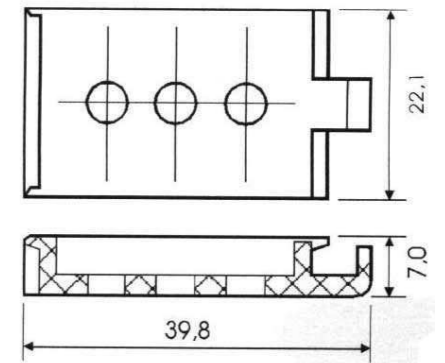

Protection cover GAMMA

Function

Sealable front cover for series GAMMA

Mechanical design

Plastic cover

| | | |
|------------------|------------------------|----------------|
| FA-G2 (IPS 22,5) | Front cover Gamma 22.5 | Art.No. 070160 |
|------------------|------------------------|----------------|

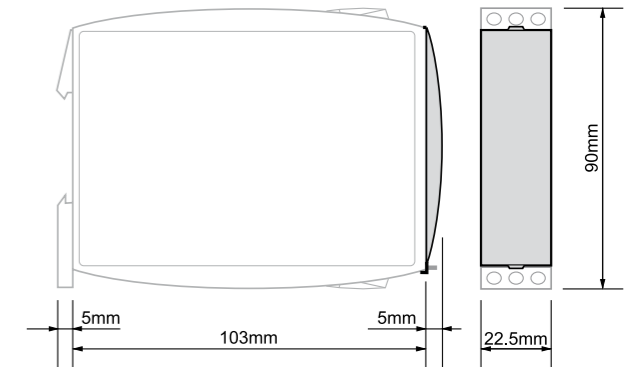

Remote potentiometer RONDO R2

Remote potentiometer for front panel mounting. With the remote potentiometer time values can be adjusted from a distance.

Maximum adjustment value:

| | | |
|-----|--------------|----------------|
| 1MΩ | (R2 1MΩ 0.1) | scale 0.1 to 1 |
| 1MΩ | (R2 1MΩ 0.3) | scale 0.3 to 3 |

| | | |
|--------------|---|--------|
| Connections: | 1 | First |
| | 2 | Wiper |
| | 3 | Finish |

Base accuracy: ±10% (of maximum scale value)

Repetition accuracy: ≤0,01%

| | | |
|--------------|-----------------------------------|----------------|
| R2 1MOHM 0,1 | Remote potentiometer, scale 0,1-1 | Art.No. 282130 |
| R2 1MOHM 0,3 | Remote potentiometer, scale 0,3-3 | Art.No. 282133 |
| R20 10KOHM | Remote potentiometer, scale 1-10 | Art.No. 282131 |



INDEX

1. Sensing & Monitoring relays S.

GAMMA

| | |
|--------------------------|----|
| G4PM690VSYL20 | 17 |
| G4PM500VSYL20 | 17 |
| G2PM400VSY20 24-240V | 17 |
| G2PM400VSY20 | 17 |
| G2PM400VSY10 | 17 |
| G2PM115VSY20 24-240V | 19 |
| G2PM230VSY20 24-240V | 19 |
| G2PM230VSY10 | 19 |
| G2PM115VSY10 | 19 |
| G2PW400V10 | 19 |
| G2PU690VS20 | 21 |
| G2PU400VSY10 230VAC | 21 |
| G2YM400VL20 | 23 |
| G2PF400VS02 | 25 |
| G2PF230VS02 | 25 |
| G2PF115VS02 | 25 |
| G2FW400VL20 24-240V | 27 |
| G2UM300VL20 | 29 |
| G2UM500VL10 230V | 29 |
| G2UM300VL20 24-240V | 29 |
| G2UW300V10 | 31 |
| G2UM10VL20 24-240V AC/DC | 31 |
| G2UM300VL10 | 31 |
| G2IM10AL10 | 33 |
| G2IM5AL20 24-240V | 33 |
| G2IM10AL20 | 33 |
| G2IM10AL20 24-240V | 33 |
| G2IM2AL20 24-240V | 35 |
| G2IM5AL10 | 35 |
| G2IM5AL20 | 35 |
| G2IO5A10 | 37 |
| G2IO10A10 | 37 |
| G2IU5A10 | 37 |
| G2IU10A10 | 37 |
| G2JM5AL20 | 39 |
| G2JM5AL20 24-240V | 39 |
| G2TMPT100L20 24-240V | 41 |
| G2TFKN02 | 43 |
| G2TF02 | 43 |
| G2TF02 24-240V | 43 |

| | |
|----------------------|----|
| G2TFKN02 24-240V | 43 |
| G2TF01 | 45 |
| G2TF01 230VAC | 45 |
| G2TF02 110VAC | 45 |
| G2TF02 230VAC | 45 |
| G2LM20 24VAC | 47 |
| G2LM20 110VAC | 47 |
| G2LM20 230VAC | 47 |
| TREND | |
| TPW400VN4X | 49 |
| TPW115VSN4X | 49 |
| TPW230VSN4X | 49 |
| TPW400VSN4X | 49 |
| TPF230VS4X | 51 |
| TPF400VS4X | 51 |
| TUW4X | 53 |
| TUH4X | 53 |
| TIW4X | 55 |
| TIH4X | 55 |
| TIF30-300mAAC4X | 55 |
| TDT4X | 57 |
| TT2X 24VAC | 57 |
| TT2X 230VAC | 57 |
| TLH4X 24VAC | 59 |
| TLH4X 230VAC | 59 |
| TLC4X 230VAC | 59 |
| KAPPA | |
| K3UM230VAC02 | 61 |
| K3UM24VDC02 | 61 |
| K3IM5AACL20 230V | 61 |
| K3PF400VSY02 | 61 |
| K3YM400VSY20 | 61 |
| ENYA | |
| E3YF400V02 0.85 | 63 |
| E3YF400VT02 HTV 0.85 | 63 |
| E3YF400VT02 0.85 | 63 |
| E3YF400VE20 0.85 | 63 |
| E1YF400V01 0.85 | 65 |
| E1YF400V01 0.70 | 65 |
| E1YF400VT01 0.85 | 65 |
| E3YM230VS20 | 67 |
| E1YM480Y/277VS10 | 67 |
| E1YM400VS10 | 67 |
| E3YU400V02 | 69 |

| | |
|-------------------|----|
| E1YU400V01 | 69 |
| E3YF400FAL02 | 71 |
| E1PF480Y/277VSY10 | 73 |
| E1PF400VSY01 | 73 |
| E3PF400VSY02 | 73 |
| E1UM230V01 | 75 |
| E1UU230V01 | 75 |
| E1IM10AACL10 | 77 |
| E3IM10AL20 | 77 |
| E1IU5AAC01 | 77 |
| E1IU500mAAC01 | 77 |
| E3TF01 | 79 |
| E3LM10 | 81 |

2. Loadmonitors S.

GAMMA

| | |
|--------------------------|-----|
| G4BM690V16ATL20 | 89 |
| G4BM690V16AL20 | 89 |
| G4BM480V12ADTL20 24-240V | 91 |
| G4BM480V12ADTL20 | 91 |
| G4BM480V12AFTL20 | 93 |
| G4BM480V12ATL20 | 93 |
| G2BM480V12AFL10 | 95 |
| G2BM400V12AL10 | 95 |
| G2BM400V12AFL10 | 95 |
| G2BA480V12A 4...20mA | 97 |
| G2IA5A 4...20mA | 99 |
| G2CM400V10AL20 | 101 |
| G2CM400V2AL20 | 101 |
| G2CU400V10AL10 | 101 |

3. Time relays S.

GAMMA

| | |
|---------------------------|-----|
| G2ZMF11 24-240VAC/DC | 111 |
| G2ZMF11 | 111 |
| G2ZM20 12-240VAC/DC | 111 |
| G2ZA20 10min 24-240VAC/DC | 113 |
| G2ZA20 10min | 113 |
| G2ZIF20 24-240VAC/DC | 115 |
| G2ZIF20 | 115 |
| G2ZI20 12-240VAC/DC | 115 |
| G2ZE10 400VAC | 117 |
| G2ZS20 24-240VAC/DC | 119 |
| G2ZS20 | 119 |



| | |
|----------------------------|-----|
| DELTA | |
| D6M 12-240VAC/DC | 121 |
| D6DM 24VAC/DC 110-240VAC | 121 |
| D6DQ 24VAC/DC 110-240VAC | 121 |
| D6DE 24VAC/DC 110VAC | 123 |
| D6DE 24VDC/DC 230VAC | 123 |
| D6DET 4MIN 12-240VAC/DC | 123 |
| D6DET 40MIN 12-240VAC/DC | 123 |
| D6DR 24VAC/DC 110VAC | 125 |
| D6DR 24VAC/DC 230VAC | 125 |
| D6A 3MIN 24-240VAC/DC | 125 |
| D6A 10MIN 24-240VAC/DC | 125 |
| D6DI 24VAC/DC 110-240VAC | 127 |
| D6DS 24VAC/DC 110-240VAC | 129 |
| KAPPA | |
| K3ZM20 12-240VAC/DC | 131 |
| K3ZM20P 12-240V AC/DC | 131 |
| K3ZA20 24-240V AC/DC | 131 |
| K3ZI20 12-240VAC/DC | 131 |
| K3ZS20 12-240VAC/DC | 131 |
| PLUS | |
| PDM20F 24VAC/DC 110-240VAC | 133 |
| PDM11 24VAC/DC 110-240VAC | 133 |
| PDI20F 24VAC/DC 110-240VAC | 133 |
| ENYA | |
| E1ZM10 12-240VAC/DC | 135 |
| E1ZM10 24-240VAC/DC | 135 |
| E3ZM20 12-240VAC/DC | 135 |
| E1ZMQ10 24-240VAC/DC | 135 |
| E1ZMW10 24-240VAC/DC | 135 |
| E1Z1E10 24-240V AC/DC | 137 |
| E1Z1R10 24-240V AC/DC | 137 |
| E1Z1ER10 24-240V AC/DC | 137 |
| E1ZI10 12-240VAC/DC | 139 |
| E3ZI20 12-240VAC/DC | 139 |
| E3ZS20 12-240VAC/DC | 141 |
| E1ZTPNC 230VAC | 143 |
| E1ZTP 230VAC | 143 |
| E1ZWI | 143 |
| E1ZNT 230V AC | 145 |
| FRONT | |
| FSM10 24V AC/DC | 147 |
| FSM10 100-240V AC | 147 |
| COMBI | |
| COM3TP 24-240V AC/DC | 149 |
| RONDO | |
| SRE2 | 151 |
| SRW2 | 153 |

4. Monitoring systems and Compact control units S.

| | |
|---------------------|-----|
| WatchDog pro | |
| G4WDCU MMC | 163 |
| G2UI1 10V | 165 |

| | |
|-----------------|-----|
| G2UI1 300V | 165 |
| G2PI1 480V | 167 |
| G2PI1 400V | 167 |
| G2YI3 60mV | 169 |
| G2II1 5A | 171 |
| G2II1 10A | 171 |
| G2JI1 5A | 173 |
| G2JI1 1A | 173 |
| G2BI1 400V12A | 175 |
| G2CI1 400V12A | 177 |
| G2TI4 PT | 179 |
| G2DI4 24V | 181 |
| G2DI4 230V | 181 |
| G2DI4 SC | 181 |
| G2DI4 PTCK | 183 |
| G2DI8 24V | 185 |
| G2DO4 R | 187 |
| G2DO4 SP24VDC | 187 |
| G2DO4 SN24VDC | 187 |
| G2DO8 SPC24VDC | 189 |
| G2AM4 M | 191 |
| G2FBC MB-RTU | 193 |
| G2FBC MB-TCP | 193 |
| G2FBC PB-DPV1 | 193 |
| G2WDGW2 MB-RTU | 195 |
| G2WDGW2 MB-TCP | 195 |
| G2WDGW2 PB-DVP1 | 195 |
| G2RBC | 197 |
| ECO | |
| ECO 8 III SYS | 201 |
| ECO 8 III GATE | 201 |
| STEP-T | |
| STEP-T8 110VAC | 203 |
| STEP-T8 230VAC | 203 |
| GAMMA | |
| G2ASMA20 | 205 |

5. Power electronics S.

Softstarter

| | |
|--------------------------------|-----|
| TSG | 210 |
| MSG | 210 |
| EUROSTART | 211 |
| ESG | 212 |
| AUCOM | 213 |
| Braking units | |
| MBG | 214 |
| BG | 214 |
| Thyristor control units | |
| TST1 | 215 |
| TST3 | 215 |
| ESGT | 216 |

6. Switching relays & further automation components S.

Switching relays

| | |
|---------------------------|-----|
| Miniature relays (RA, RM) | 220 |
| Relaysets | 221 |
| Industrial relays (RT) | 222 |
| Print relays (RP) | 223 |
| Interface relays (SKR) | 224 |

Coupling units

| | |
|------------------|-----|
| E1K 24-240VAC/DC | 225 |
| E3K 12-240VAC/DC | 225 |
| OCTO | 227 |
| HAR1 | 227 |
| OVP1 24VAC/DC | 229 |
| OCP1 24VAC/DC | 229 |
| OVL1 24VAC/DC | 231 |
| OCL1 24VAC/DC | 231 |
| TREND | 233 |
| TD1 | 233 |
| TD2 | 233 |
| VOX | 235 |
| KM2X04P-M 24VDC | 235 |
| KM2X04M-M 240VDC | 235 |

Signal converter

| | |
|------------------|-----|
| M1MTB1 24-240V | 237 |
| M1MTN1 24-240V | 237 |
| M1MPT100 24-240V | 237 |
| M1MTNI | 239 |

Safety relays

| | |
|----|-----|
| S2 | 243 |
| ZK | 243 |

Digital time switches

| | |
|----------------------------|-----|
| TSCx8 DIN rail mounting | 244 |
| TSC44 Front panel mounting | 244 |

Hour meters

| | |
|-----|-----|
| TBG | 245 |
| TBW | 245 |

DC power supply

| | |
|------------------------|-----|
| Transformers (RNG) | 246 |
| Switching power supply | 247 |

7. Accessories S.

Power modules (TR2, TR3)

Switching power supply (SNT)

Probes (SK)

Current transformer (WSW, DSW)

Other