

# NHD-12864AZ-FL-YBW

## Graphic Liquid Crystal Display Module

NHD-	Newhaven Display
12864-	128 x 64 pixels
AZ-	Model
F-	Transflective
L-	Yellow/Green LED backlight
Y-	STN- Yellow/Green
B-	6:00 View
W-	Wide Temperature (-20°C ~ +70°C)
	<b>RoHS Compliant</b>

**Newhaven Display International, Inc.**

2511 Technology Drive, Suite 101

Elgin IL, 60124

Ph: 847-844-8795

Fax: 847-844-8796

[www.newhavendisplay.com](http://www.newhavendisplay.com)

[nhtech@newhavendisplay.com](mailto:nhtech@newhavendisplay.com)

[nhsales@newhavendisplay.com](mailto:nhsales@newhavendisplay.com)

## Document Revision History

Revision	Date	Description	Changed by
0	12/23/2008	Initial Release	-
1	4/2/2010	User guide reformat	BE
2	5/21/2010	Updated Pin Out and Electrical Characteristics	MC
3	12/17/2012	Controller information updated	AK

## Functions and Features

- 128x64 pixels
- Built-in NT7108C controller
- +5.0V power supply
- 1/64 duty, 1/9 bias
- RoHS Compliant



## Pin Description and Wiring Diagram

Pin No.	Symbol	External Connection	Function Description
1	VSS	Power Supply	Ground
2	VDD	Power Supply	Power supply for Logic (+5.0V)
3	V0	Adj Power Supply	Power Supply for contrast (approx. -3.7V)
4	RS	MPU	Register select: 1=Data, 0=Instruction
5	R/W	MPU	Read/Write select signal, R/W=1: Read R/W: =0: Write
6	E	MPU	Operation enable signal. Falling edge triggered.
7-14	DB0-DB7	MPU	This is an 8-bit-directional data bus
15	CS1B	MPU	Chip Selection: CS1=H, CS2=L → select IC1 (left side) CS1=L, CS2=H → select IC2 (right side)
16	CS2B	MPU	
17	/RES	MPU	Active LOW Reset signal
18	VEE	Power Supply	Negative voltage output (-5.0V)
19	LED+	Power Supply	Power for LED backlight (+5.0V via on-board resistor)
20	LED-	Power Supply	Ground for Backlight

Recommended LCD connector: 2.54mm pitch pins

Backlight connector: ---

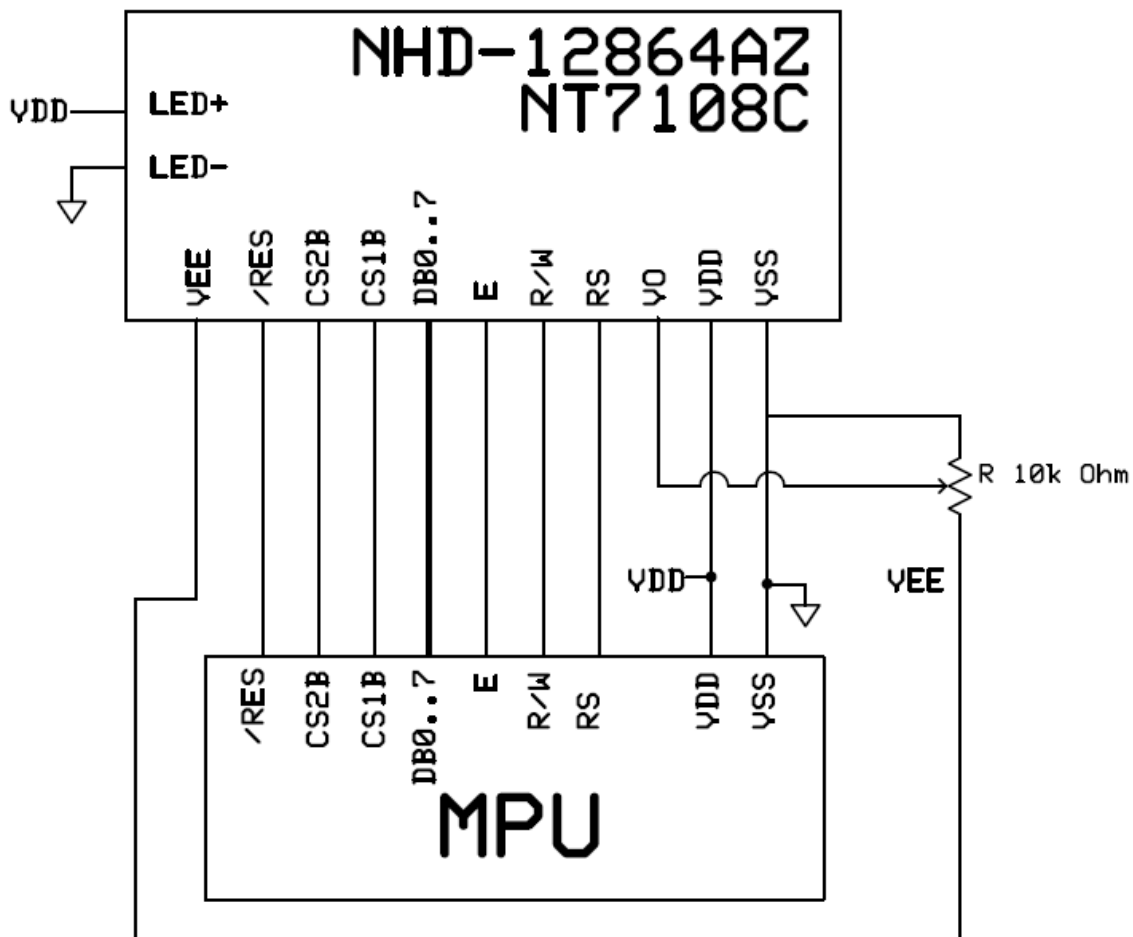

## Electrical Characteristics

Item	Symbol	Condition	Min.	Typ.	Max.	Unit
Operating Temperature Range	Top	Absolute Max	-20	-	+70	°C
Storage Temperature Range	Tst	Absolute Max	-30	-	+80	°C
Supply Voltage	VDD		4.7	5.0	5.5	V
Supply Current	IDD	Ta=25°, VDD=5.0V	-	3.5	4.5	mA
Supply for LCD (contrast)	VDD-V0	Ta=25°	-	8.7	9.0	V
"H" Level input	Vih		0.7*VDD	-	VDD	V
"L" Level input	Vil		0		0.3*VDD	V
"H" Level output	Voh		2.4	-	-	V
"L" Level output	Vol		-	-	0.4	V
Backlight Supply Voltage	Vled		-	5.0	-	V
Backlight Supply Current	Iled	Vled=5.0V, R=68Ω	-	120	-	mA

## Optical Characteristics

Item	Symbol	Condition	Min.	Typ.	Max.	Unit
Viewing Angle – Top		Cr ≥ 2	-	35	-	°
Viewing Angle – Bottom			-	60	-	°
Viewing Angle – Left			-	40	-	°
Viewing Angle – Right			-	40	-	°
Contrast Ratio	Cr		3	5	-	
Response Time (rise)	Tr		-	150	250	ms
Response Time (fall)	Tf		-	200	300	ms

## Controller Information

Built-in NT7108C controller.

Please download specification at [http://www.newhavendisplay.com/app\\_notes/NT7108.pdf](http://www.newhavendisplay.com/app_notes/NT7108.pdf)

## Table of Commands

Instruction	RS	R/W	DB7	DB6	DB5	DB4	DB3	DB2	DB1	DB0	Function
Display on/off	L	L	L	L	H	H	H	H	H	L/H	Controls the display on or off. Internal status and display RAM data is not affected. L:OFF, H:ON
Set address (Y address)	L	L	L	H	Y address (0-63)					Sets the Y address in the Y address counter.	
Set page (X address)	L	L	H	L	H	H	H	Page (0-7)			Sets the X address at the X address register.
Display Start line (Z address)	L	L	H	H	Display start line (0-63)					Indicates the display data RAM displayed at the top of the screen.	
Status read	L	H	Busy	L	On/Off	Reset	L	L	L	L	Read status. BUSY L: Ready H: In operation ON/OFF L: Display ON H: Display OFF RESET L: Normal H: Reset
Write display data	H	L	Write data								Writes data (DB0: 7) into display data RAM. After writing instruction, Y address is increased by 1 automatically.
Read display data	H	H	Read data								Reads data (DB0: 7) from display data RAM to the data bus.

## Timing Characteristics

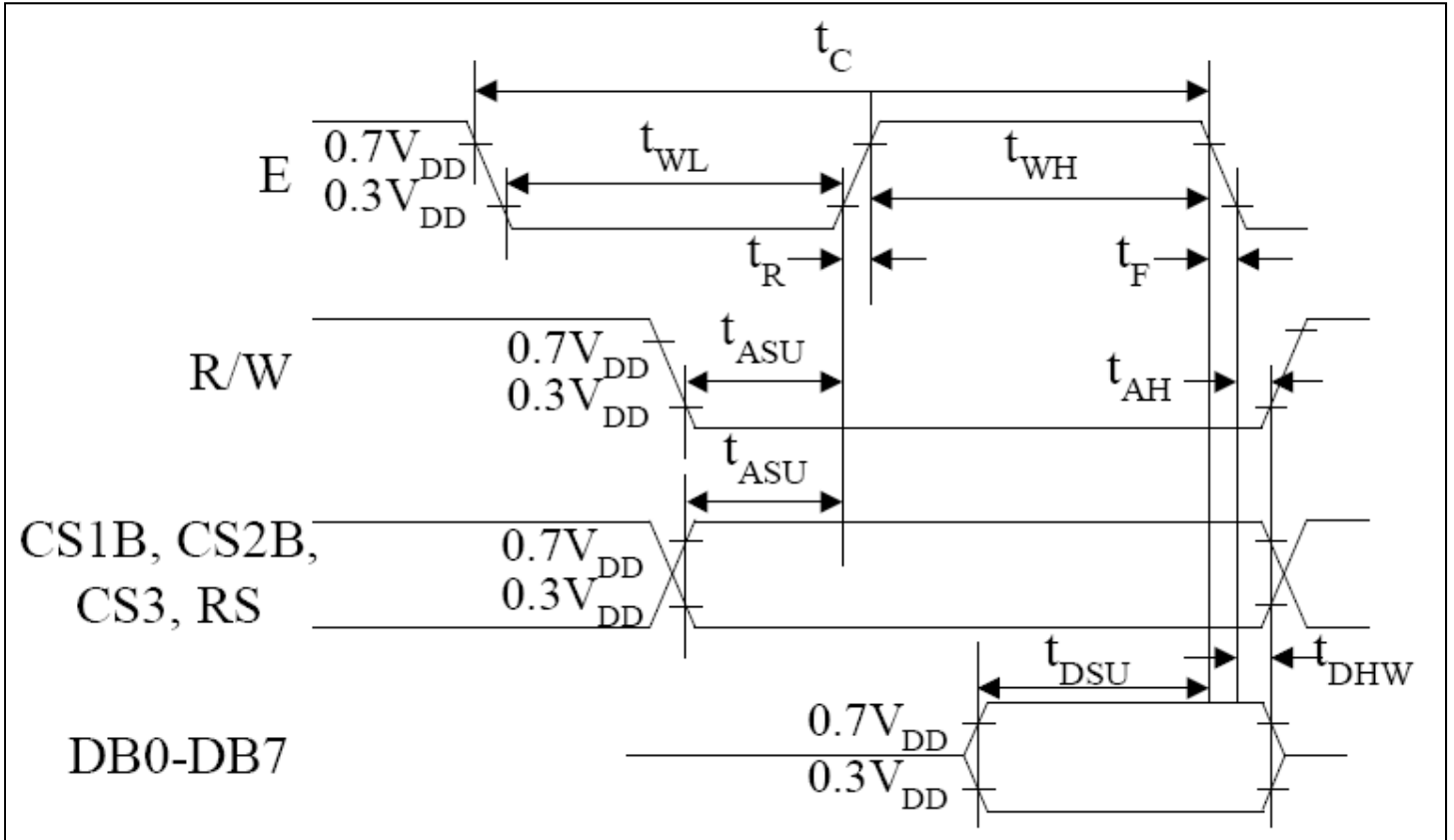

Characteristic	Symbol	Min	Type	Max	Unit
E cycle	$t_c$	1000	-	-	ns
E high level width	$t_{WH}$	450	-	-	
E low level width	$t_{WL}$	450	-	-	
E rise time	$t_R$	-	-	25	
E fall time	$t_F$	-	-	25	
Address set-up time	$t_{ASU}$	140	-	-	
Address hold time	$t_{AH}$	10	-	-	
Data set-up time	$t_{DSU}$	200	-	-	
Data delay time	$t_D$	-	-	320	
Data hold time (write)	$t_{DHW}$	10	-	-	
Data hold time (read)	$t_{DHR}$	20	-	-	

## Example Initialization Program

```
'-----  
'DB0-DB7  7-14          P1  
'CS2      16           P3.6  
'CS1      15           P3.1  
'RST      17           P3.2  
'R/W      5            P3.7  
'D/I      4            P3.0  
'E        6            P3.4  
'-----  
Sub Init  
  Reset P3.2  
  Set P3.2  
  Reset P3.4  
  Reset P3.0  
  Reset P3.7  
  Reset P3.6  
  Reset P3.1  
  A = &H3F  
  Call Comleft           'display on  
  Call Comright         'display on  
End Sub  
'-----  
Sub Comleft  
  P1 = A  
  Set P3.6  
  Reset P3.0  
  Set P3.4  
  Reset P3.4  
  Reset P3.6  
End Sub  
  
Sub Comright  
  P1 = A  
  Set P3.1  
  Reset P3.0  
  Set P3.4  
  Reset P3.4  
  Reset P3.1  
End Sub  
  
Sub Writeleft  
  P1 = A  
  Set P3.6  
  Set P3.0  
  Set P3.4  
  Reset P3.4  
  Reset P3.6  
End Sub  
  
Sub Writeright  
  P1 = A  
  Set P3.1  
  Set P3.0  
  Set P3.4  
  Reset P3.4  
  Reset P3.1  
End Sub
```



## Quality Information

Test Item	Content of Test	Test Condition	Note
High Temperature storage	Endurance test applying the high storage temperature for a long time.	+80°C , 48hrs	2
Low Temperature storage	Endurance test applying the low storage temperature for a long time.	-30°C , 48hrs	1,2
High Temperature Operation	Endurance test applying the electric stress (voltage & current) and the high thermal stress for a long time.	+70°C , 48hrs	2
Low Temperature Operation	Endurance test applying the electric stress (voltage & current) and the low thermal stress for a long time.	-20°C , 48hrs	1,2
High Temperature / Humidity Operation	Endurance test applying the electric stress (voltage & current) and the high thermal with high humidity stress for a long time.	+40°C , 90% RH , 48hrs	1,2
Thermal Shock resistance	Endurance test applying the electric stress (voltage & current) during a cycle of low and high thermal stress.	0°C,30min -> 25°C,5min -> 50°C,30min = 1 cycle 10 cycles	
Vibration test	Endurance test applying vibration to simulate transportation and use.	10-55Hz , 15mm amplitude. 60 sec in each of 3 directions X,Y,Z For 15 minutes	3
Static electricity test	Endurance test applying electric static discharge.	VS=800V, RS=1.5kΩ, CS=100pF One time	

**Note 1:** No condensation to be observed.

**Note 2:** Conducted after 4 hours of storage at 25°C, 0%RH.

**Note 3:** Test performed on product itself, not inside a container.

## Precautions for using LCDs/LCMs

See Precautions at [www.newhavendisplay.com/specs/precautions.pdf](http://www.newhavendisplay.com/specs/precautions.pdf)

## Warranty Information and Terms & Conditions

[http://www.newhavendisplay.com/index.php?main\\_page=terms](http://www.newhavendisplay.com/index.php?main_page=terms)