

NHD-16032AZ-FL-YBW

Graphic Liquid Crystal Display Module

NHD- Newhaven Display
16032- 160 x 32 pixels
AZ- Model
F- Transflective
L- Yellow/Green LED backlight
Y- STN- Yellow/Green
B- 6:00 View
W- Wide Temperature (-20°C ~ +70°C)
RoHS Compliant

Newhaven Display International, Inc.

2511 Technology Drive, Suite 101

Elgin IL, 60124

Ph: 847-844-8795

Fax: 847-844-8796

www.newhavendisplay.com

nhtech@newhavendisplay.com

nhsales@newhavendisplay.com

Document Revision History

Revision	Date	Description	Changed by
0	2/28/2009	Initial Release	-
1	4/9/2010	User guide reformat	BE
2	5/7/2010	Block diagram/initialization update	BE
3	1/25/2012	Mechanical drawing updated	AK
4	6/7/2013	Controller information added	AK

Functions and Features

- 160x32 pixels
- Built-in ST7920-0B Controller
- +5.0V power supply
- 1/32 duty, 1/9 bias
- RoHS Compliant

Mechanical Drawing



The drawing contained herein is the exclusive property of Newhaven Display International, Inc. and shall not be copied, reproduced, and/or disclosed in any format without permission.

Pin Description and Wiring Diagram

Pin No.	Symbol	External Connection	Function Description
1	VSS	Power Supply	Ground
2	VDD	Power Supply	Power supply for LCD and Logic (+5.0V)
3	NC	-	No Connect
4	RS	MPU	Register Select signal: 1=Data, 0=Instruction
5	R/W	MPU	Read/Write select signal, R/W=1: Read R/W: =0: Write
6	E	MPU	Operation Enable signal. Falling edge triggered.
7-14	DB0-DB7	MPU	8-bit Bi-directional data bus
15	LED+	Power Supply	Power Supply for LED backlight (+5.0V via on-board resistor)
16	LED-	Power Supply	Ground for Backlight

Recommended LCD connector: 2.54mm pitch pins

Backlight connector: - **Mates with:** -

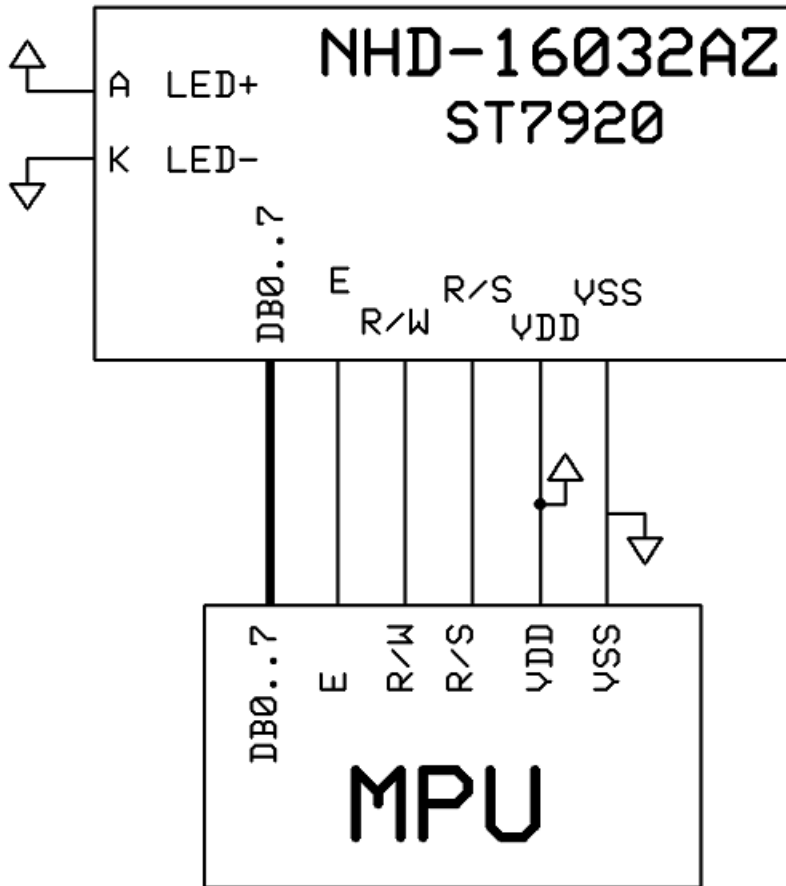

Electrical Characteristics

Item	Symbol	Condition	Min.	Typ.	Max.	Unit
Operating Temperature Range	Top	Absolute Max	-20	-	+70	°C
Storage Temperature Range	Tst	Absolute Max	-30	-	+80	°C
Supply Voltage	VDD		-	5.0	-	V
Supply Current	IDD	Ta=25°, VDD=5.0V	-	2.0	3.0	mA
Supply for LCD (contrast)	VDD-V0	-	-	-	-	-
"H" Level input	Vih		0.7*VDD	-	VDD	V
"L" Level input	Vil		-0.3	-	0.6	V
"H" Level output	Voh		0.8*VDD	-	VDD	V
"L" Level output	Vol		-	-	0.4	V
Backlight Supply Voltage	Vled		-	5.0	-	V
Backlight Supply Current	Iled	Vled=5.0V	-	120	-	mA

Optical Characteristics

Item	Symbol	Condition	Min.	Typ.	Max.	Unit
Viewing Angle – Top		Cr ≥ 2	-	30	-	°
Viewing Angle – Bottom			-	60	-	°
Viewing Angle – Left			-	45	-	°
Viewing Angle – Right			-	45	-	°
Contrast Ratio	Cr			5		
Response Time (rise)	Tr			100	150	ms
Response Time (fall)	Tf			150	200	ms

Controller Information

Built-in ST7920-0B.

Please download specification at http://www.newhavendisplay.com/app_notes/ST7920.pdf

Table of Commands

Instruction Set 1: (RE=0: Basic Instruction)

Inst.	Code										Description	Exec time (540KHZ)	
	RS	RW	DB7	DB6	DB5	DB4	DB3	DB2	DB1	DB0			
Display Clear	0	0	0	0	0	0	0	0	0	1	Fill DDRAM with "20H" and set DDRAM address counter (AC) to "00H".	1.6 ms	
Return Home	0	0	0	0	0	0	0	0	0	1	X	Set DDRAM address counter (AC) to "00H", and put cursor to origin : the content of DDRAM are not changed	72 us
Entry Mode Set	0	0	0	0	0	0	0	0	1	I/D	S	Set cursor position and display shift when doing write or read operation	72 us
Display Control	0	0	0	0	0	0	0	1	D	C	B	D=1: Display ON C=1: Cursor ON B=1: Character Blink ON	72 us
Cursor Display Control	0	0	0	0	0	1	S/C	R/L	X	X	X	Cursor position and display shift control; the content of DDRAM are not changed	72 us
Function Set	0	0	0	0	1	DL	X	0	RE	X	X	DL=1 8-bit interface DL=0 4-bit interface RE=1: extended instruction RE=0: basic instruction	72 us
Set CGRAM Address.	0	0	0	1	AC5	AC4	AC3	AC2	AC1	AC0	AC0	Set CGRAM address to address counter (AC) Make sure that in extended instruction SR=0 (scroll or RAM address select)	72 us
Set DDRAM Address.	0	0	1	0	AC6	AC5	AC4	AC3	AC2	AC1	AC0	Set DDRAM address to address counter (AC) AC6 is fixed to 0	72 us
Read Busy Flag (BF) & AC.	0	1	BF	AC6	AC5	AC4	AC3	AC2	AC1	AC0	AC0	Read busy flag (BF) for completion of internal operation, also Read out the value of address counter (AC)	0 us
Write RAM	1	0	D7	D6	D5	D4	D3	D2	D1	D0	D0	Write data to internal RAM (DDRAM/CGRAM/GDRAM)	72 us
Read RAM	1	1	D7	D6	D5	D4	D3	D2	D1	D0	D0	Read data from internal RAM (DDRAM/CGRAM/GDRAM)	72 us

Instruction set 2: (RE=1: extended instruction)

Inst.	Code										Description	Exec time (540KHZ)		
	RS	RW	DB7	DB6	DB5	DB4	DB3	DB2	DB1	DB0				
Standby	0	0	0	0	0	0	0	0	0	1	Enter standby mode, any other instruction can terminate. COM1...32 are halted.	72 us		
Scroll or RAM Address. Select	0	0	0	0	0	0	0	0	0	1	SR SR=1: enable vertical scroll position SR=0: enable CGRAM address (basic instruction)	72 us		
Reverse (by line)	0	0	0	0	0	0	0	0	1	R1 R0	Select 1 out of 4 line (in DDRAM) and decide whether to reverse the display by toggling this instruction R1,R0 initial value is 0,0	72 us		
Extended Function Set	0	0	0	0	1	DL	X	1	RE	G	0	DL=1 :8-bit interface DL=0 :4-bit interface RE=1: extended instruction set RE=0: basic instruction set G=1 :graphic display ON G=0 :graphic display OFF	72 us	
Set Scroll Address	0	0	0	1	AC5	AC4	AC3	AC2	AC1	AC0	SR=1: AC5~AC0 the address of vertical scroll	72 us		
Set Graphic Display RAM Address	0	0	1	0	0	0	AC3	AC2	AC1	AC0	0	0	Set GDRAM address to address counter (AC) Set the vertical address first and followed the horizontal address by consecutive writings Vertical address range: AC5...AC0 Horizontal address range: AC3...AC0	72 us

Timing Characteristics

MPU write data to ST7920

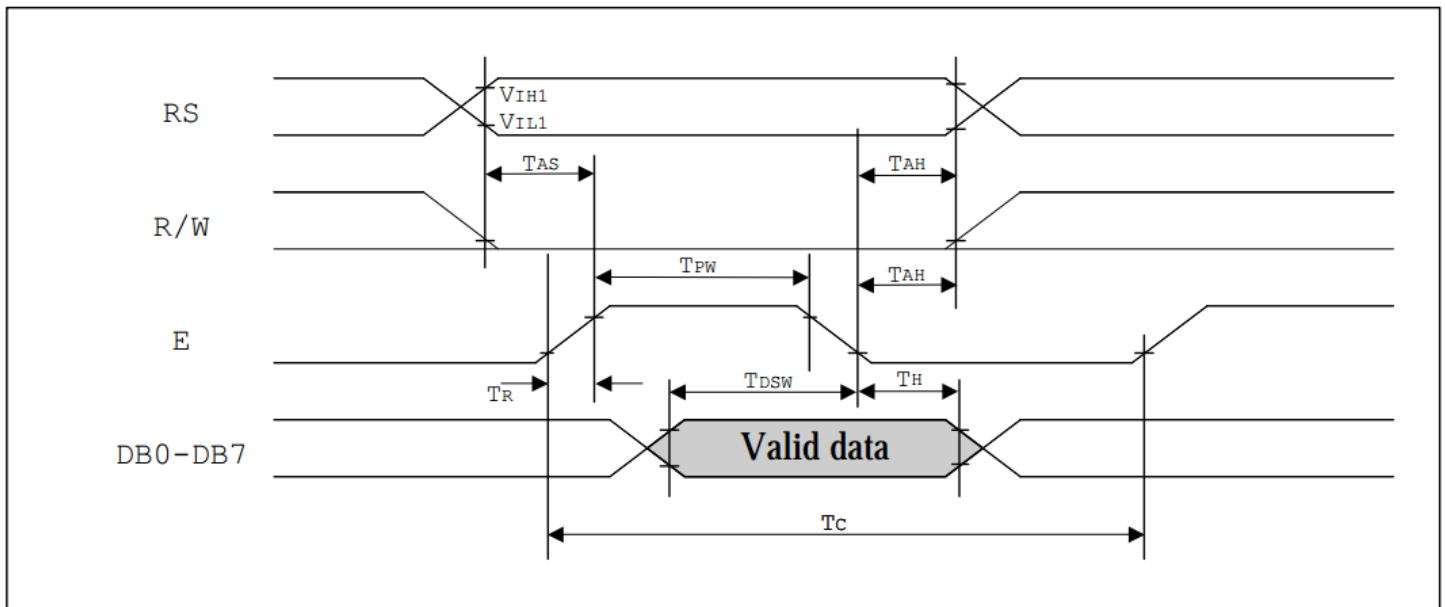

Write Mode (Writing data from MPU to ST7920)

T_C	Enable Cycle Time	Pin E	1200	-	-	ns
T_{PW}	Enable Pulse Width	Pin E	140	-	-	ns
T_R, T_F	Enable Rise/Fall Time	Pin E	-	-	25	ns
T_{AS}	Address Setup Time	Pins: RS,RW,E	10	-	-	ns
T_{AH}	Address Hold Time	Pins: RS,RW,E	20	-	-	ns
T_{DSW}	Data Setup Time	Pins: DB0 - DB7	40	-	-	ns
T_H	Data Hold Time	Pins: DB0 - DB7	20	-	-	ns

MPU read data from ST7920

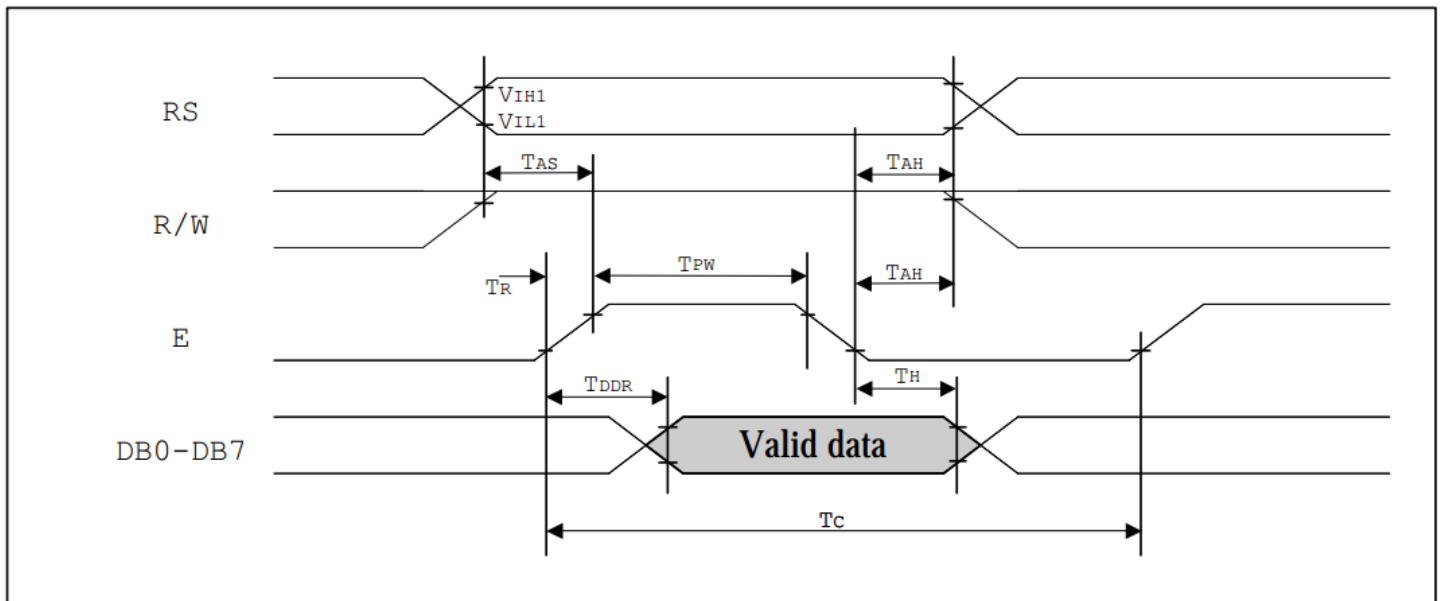

<i>Read Mode (Reading Data from ST7920 to MPU)</i>						
T_C	Enable Cycle Time	Pin E	1200	-	-	ns
T_{PW}	Enable Pulse Width	Pin E	140	-	-	ns
T_{R,T_F}	Enable Rise/Fall Time	Pin E	-	-	25	ns
T_{AS}	Address Setup Time	Pins: RS,RW,E	10	-	-	ns
T_{AH}	Address Hold Time	Pins: RS,RW,E	20	-	-	ns
T_{DDR}	Data Delay Time	Pins: DB0 - DB7	-	-	100	ns
T_H	Data Hold Time	Pins: DB0 - DB7	20	-	-	ns

Built-in Font Table

Please see: http://www.newhavendisplay.com/app_notes/ST7920-0B_font.pdf

Example Initialization Program

```
//-----  
#include <REG52.H>  
#include "AL.h"  
sbit ID = P3^0;  
sbit RW = P3^7;  
sbit E = P3^4;  
  
//-----  
void Init()  
{  
    Wcom(0x38);  
    Wcom(0x0C);  
    Wcom(0x06);  
    Wcom(0x02);  
    Wcom(0x01);  
    delay(10);  
    Row = 0x80;  
    for(Counthi = 1; Counthi <=32; Counthi++)  
    {  
        Wcom(0x3E);  
        Wcom(Row);  
        Wcom(0x80);  
        for(Count = 1; Count <=40; Count++)  
        {  
            Wdata(0x00);  
        }  
        Row++;  
    }  
}  
//-----  
void Wcom(char i)  
{  
    P1 = i;  
    ID = 0;  
    RW = 0;  
    E = 1;  
    delay(1);  
    E = 0;  
}  
//-----  
void Wdata(char i)  
{  
    P1 = i;  
    ID = 1;  
    RW = 0;  
    E = 1;  
    delay(1);  
    E = 0;  
}  
//-----
```

Quality Information

Test Item	Content of Test	Test Condition	Note
High Temperature storage	Endurance test applying the high storage temperature for a long time.	+80°C , 48hrs	2
Low Temperature storage	Endurance test applying the low storage temperature for a long time.	-30°C , 48hrs	1,2
High Temperature Operation	Endurance test applying the electric stress (voltage & current) and the high thermal stress for a long time.	+70°C , 48hrs	2
Low Temperature Operation	Endurance test applying the electric stress (voltage & current) and the low thermal stress for a long time.	-20°C , 48hrs	1,2
High Temperature / Humidity Operation	Endurance test applying the electric stress (voltage & current) and the high thermal with high humidity stress for a long time.	+40°C , 90% RH , 48hrs	1,2
Thermal Shock resistance	Endurance test applying the electric stress (voltage & current) during a cycle of low and high thermal stress.	0°C,30min -> 25°C,5min -> 50°C,30min = 1 cycle 10 cycles	
Vibration test	Endurance test applying vibration to simulate transportation and use.	10-55Hz , 15mm amplitude. 60 sec in each of 3 directions X,Y,Z For 15 minutes	3
Static electricity test	Endurance test applying electric static discharge.	VS=800V, RS=1.5kΩ, CS=100pF One time	

Note 1: No condensation to be observed.

Note 2: Conducted after 4 hours of storage at 25°C, 0%RH.

Note 3: Test performed on product itself, not inside a container.

Precautions for using LCDs/LCMs

See Precautions at www.newhavendisplay.com/specs/precautions.pdf

Warranty Information and Terms & Conditions

http://www.newhavendisplay.com/index.php?main_page=terms