

NHD-240128BZ-NSW-BTW-3V3

Graphic Liquid Crystal Display Module

NHD-	Newhaven Display
240128-	240 x 128 pixels
BZ-	Model
N-	Transmissive
SW-	Side White LED Backlight
B-	STN - Blue (-)
T-	12:00 view
W-	Wide Temperature (-20°C ~ +70°C)
3V3-	3.3VDD

RoHS Compliant

Newhaven Display International, Inc.

2511 Technology Drive, Suite 101
Elgin IL, 60124

Ph: 847-844-8795 Fax: 847-844-8796

www.newhavendisplay.com

nhtech@newhavendisplay.com

nhsales@newhavendisplay.com

Document Revision History

Revision	Date	Description	Changed by
0	10/5/2007	Initial Release	-
1	6/4/2008	Update table of contents	CL
2	4/22/2010	User guide reformat	BE
3	11/30/2010	Updated Mechanical Drawing / Updated Block Diagram	AK
4	2/16/2011	Pin description / Electrical characteristics updated	AK
5	6/13/2011	Electrical characteristics/contrast updated	BE
6	1/24/2012	Pin description updated	AK

Functions and Features

- 240 x 128 pixels
- Built-in RA8835 controller
- +3.3V Power Supply
- 1/128 duty, 1/12 bias
- RoHS Compliant

Mechanical Drawing

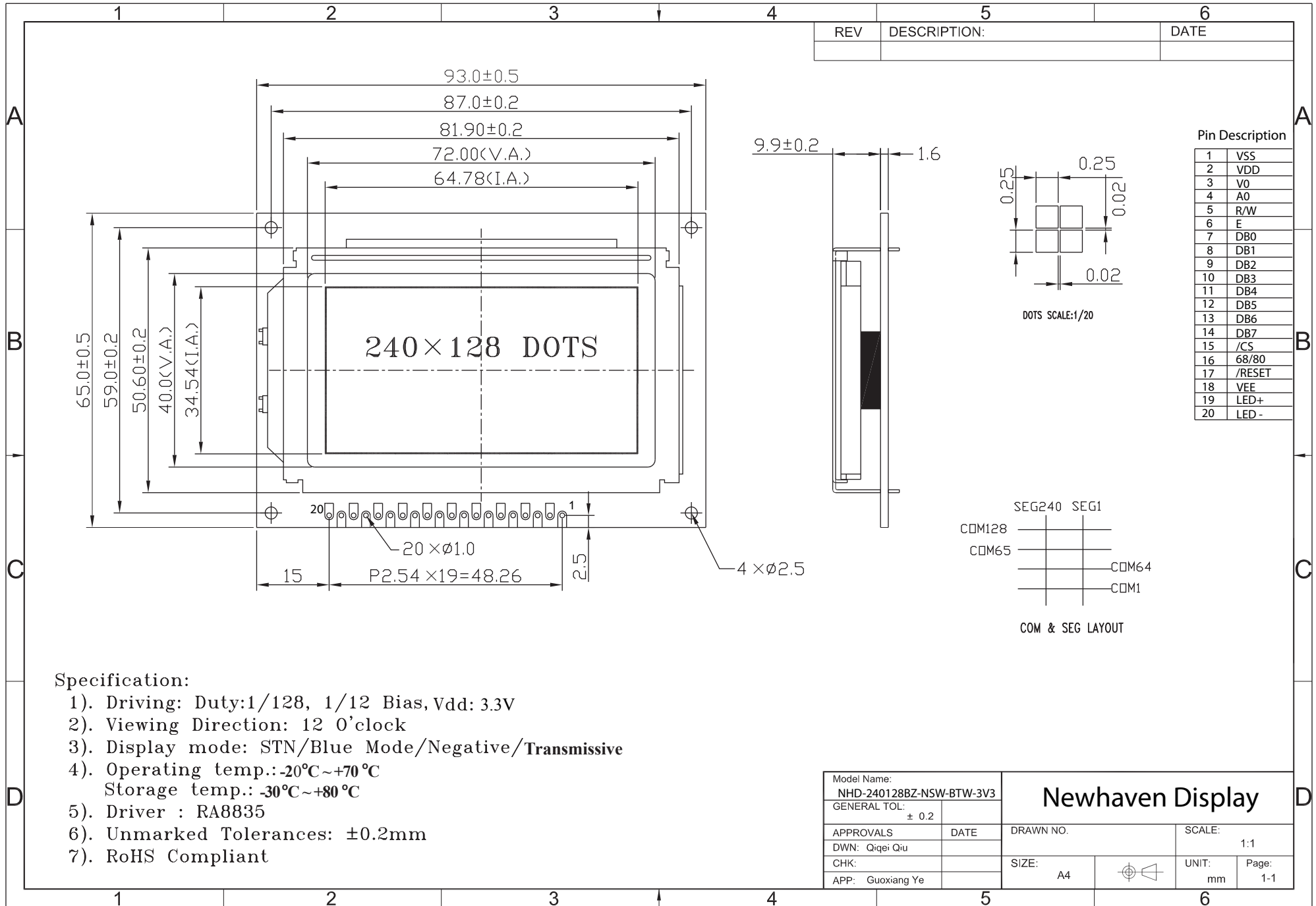

Model Name: NHD-240128BZ-NSW-BTW-3V3		Newhaven Display	
GENERAL TOL: ± 0.2			
APPROVALS	DATE	DRAWN NO.	SCALE: 1:1
DWN: Qiqei Qiu		SIZE: A4	UNIT: mm
CHK:			Page: 1-1
APP: Guoxiang Ye			

Pin Description and Wiring Diagram

Pin No.	Symbol	External Connection	Function Description
1	VSS	Power Supply	Ground
2	VDD	Power Supply	Power supply for logic (+3.3V)
3	VO	Adj. Power Supply	Power Supply for contrast (approx 19.2V)
4	A0	MPU	Register Select signal. 0: data; 1: instruction
5	R/W	MPU	Read/Write select signal, R/W=1: Read R/W=0: Write
6	E	MPU	Operation enable signal. Falling edge triggered.
7-10	DB0-DB3	MPU	Four low order bi-directional three-state data bus lines. These four are not used during 4-bit operation.
11-14	DB4-DB7	MPU	Four high order bi-directional three-state data bus lines.
15	/CS	MPU	Active LOW Chip Select Signal
16	68/80	MPU	Interface Select Pin. 0: 8080 Family 1: 6800 Family
17	/RESET	MPU	Active LOW reset signal
18	VEE	Power Supply	Positive voltage supply output (+20V)
19	LED+	Power Supply	Power supply for LED Backlight (+3.0V)
20	LED-	Power Supply	Ground for Backlight

Recommended LCD connector: 2.54mm pitch pins

Backlight connector: - **Mates with:** -

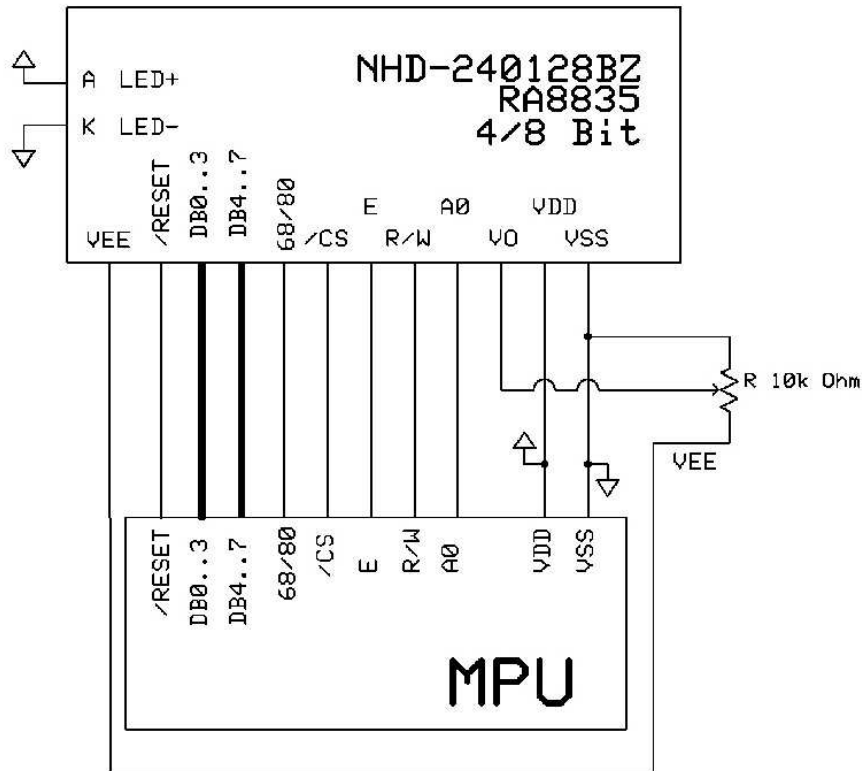

Electrical Characteristics

Item	Symbol	Condition	Min.	Typ.	Max.	Unit
Operating Temperature Range	Top	Absolute Max	-20	-	+70	°C
Storage Temperature Range	Tst	Absolute Max	-30	-	+80	°C
Supply Voltage	VDD		2.7	3.3	3.5	V
Supply Current	IDD	VDD=5.0V	-	3.5	5.5	mA
Supply for LCD (contrast)	VDD-V0	Ta=25°	-	-15.9	-	V
"H" Level input	VIH		2.2	-	VDD	V
"L" Level input	VIL		0	-	0.6	V
"H" Level output	VOH		2.4	-	-	V
"L" Level output	VOL		-	-	0.4	V
Backlight Supply Voltage	Vled	-	-	3.0	-	V
Backlight Supply Current	Iled	Vled=3.0V	-	36	-	mA

Optical Characteristics

Item	Symbol	Condition	Min.	Typ.	Max.	Unit
Viewing Angle - Vertical	AV	Cr ≥ 2	-	60	-	°
Viewing Angle - Vertical	AV	Cr ≥ 2	-	35	-	°
Viewing Angle – Horizontal	AH	Cr ≥ 2	-	40	-	°
Viewing Angle - Horizontal	AH	Cr ≥ 2	-	40	-	°
Contrast Ratio	Cr		-	6	-	-
Response Time (rise)	Tr	-	-	150	250	ms
Response Time (fall)	Tf	-	-	150	250	ms

Controller Information

Built-in RA8835. Download specification at http://www.newhavendisplay.com/app_notes/RA8835.pdf

Table of Commands

Class	Command	Code											Hex	Command Description	Command Read Parameters		
		RD	WR	A0	D7	D6	D5	D4	D3	D2	D1	D0			No. of Bytes	Section	
System Control	SYSTEM SET	1	0	1	0	1	0	0	0	0	0	0	0	40	Initialize device and display	8	9-2-1
	SLEEP IN	1	0	1	0	1	0	1	0	0	1	1	53	Enter standby mode	0	9-2-2	
Display Control	DISPLAY ON/OFF	1	0	1	0	1	0	1	1	0	0	D	58, 59	Enable and disable display and display flashing	1	9-3-1	
	SCROLL	1	0	1	0	1	0	0	0	1	0	0	44	Set display start address and display regions	10	9-3-2	
	CSRFORM	1	0	1	0	1	0	1	1	1	0	1	5D	Set cursor type	2	9-3-3	
	CGRAM ADR	1	0	1	0	1	0	1	1	1	0	0	5C	Set start address of character generator RAM	2	9-3-6	
	CSRDIR	1	0	1	0	1	0	0	1	1	CD 1	CD 0	4C to 4F	Set direction of cursor movement	0	9-3-4	
	HDOT SCR	1	0	1	0	1	0	1	1	0	1	0	5A	Set horizontal scroll position	1	9-3-7	
	OVLAY	1	0	1	0	1	0	1	1	0	1	1	5B	Set display overlay format	1	9-3-5	
Drawing Control	CSRW	1	0	1	0	1	0	0	0	1	1	0	46	Set cursor address	2	9-r1	
	CSRR	1	0	1	0	1	0	0	0	1	1	1	47	Read cursor address	2	9-4-2	
Memory Control	MWRITE	1	0	1	0	1	0	0	0	0	1	0	42	Write to display memory	—	9-5-1	
	MREAD	1	0	1	0	1	0	0	0	0	1	1	43	Read from display memory	—	9-5-2	

Timing Characteristics

10-3-1 8080 Family Interface Timing

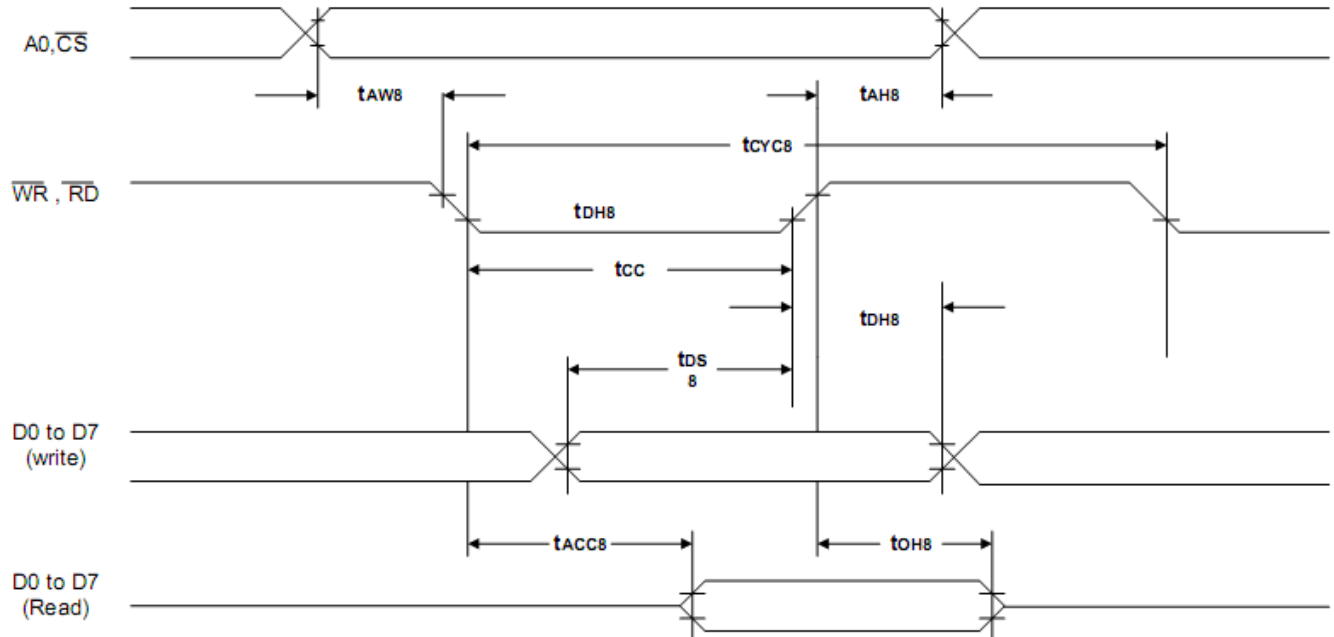

$T_a = -20 \text{ to } 75^\circ\text{C}$

Signal	Symbol	Parameter	$V_{DD} = 4.5 \text{ to } 5.5\text{V}$		$V_{DD} = 2.7 \text{ to } 4.5\text{V}$		Unit	Condition
			Min.	Max.	Min.	Max.		
A0, \overline{CS}	t_{AH8}	Address hold time	10	—	10	—	ns	CL = 100pF
	t_{AW8}	Address setup time	0	—	0	—	ns	
\overline{WR} , \overline{RD}	t_{CYC8}	System cycle time	note.	—	note.	—	ns	
	t_{CC}	Strobe pulse width	120	—	150	—	ns	
D0 to D7	t_{DS8}	Data setup time	120	—	120	—	ns	
	t_{DH8}	Data hold time	5	—	5	—	ns	
	t_{ACC8}	\overline{RD} access time	—	50	—	80	ns	
	t_{OH8}	Output disable time	10	50	10	55	ns	

6800 Family Interface Timing

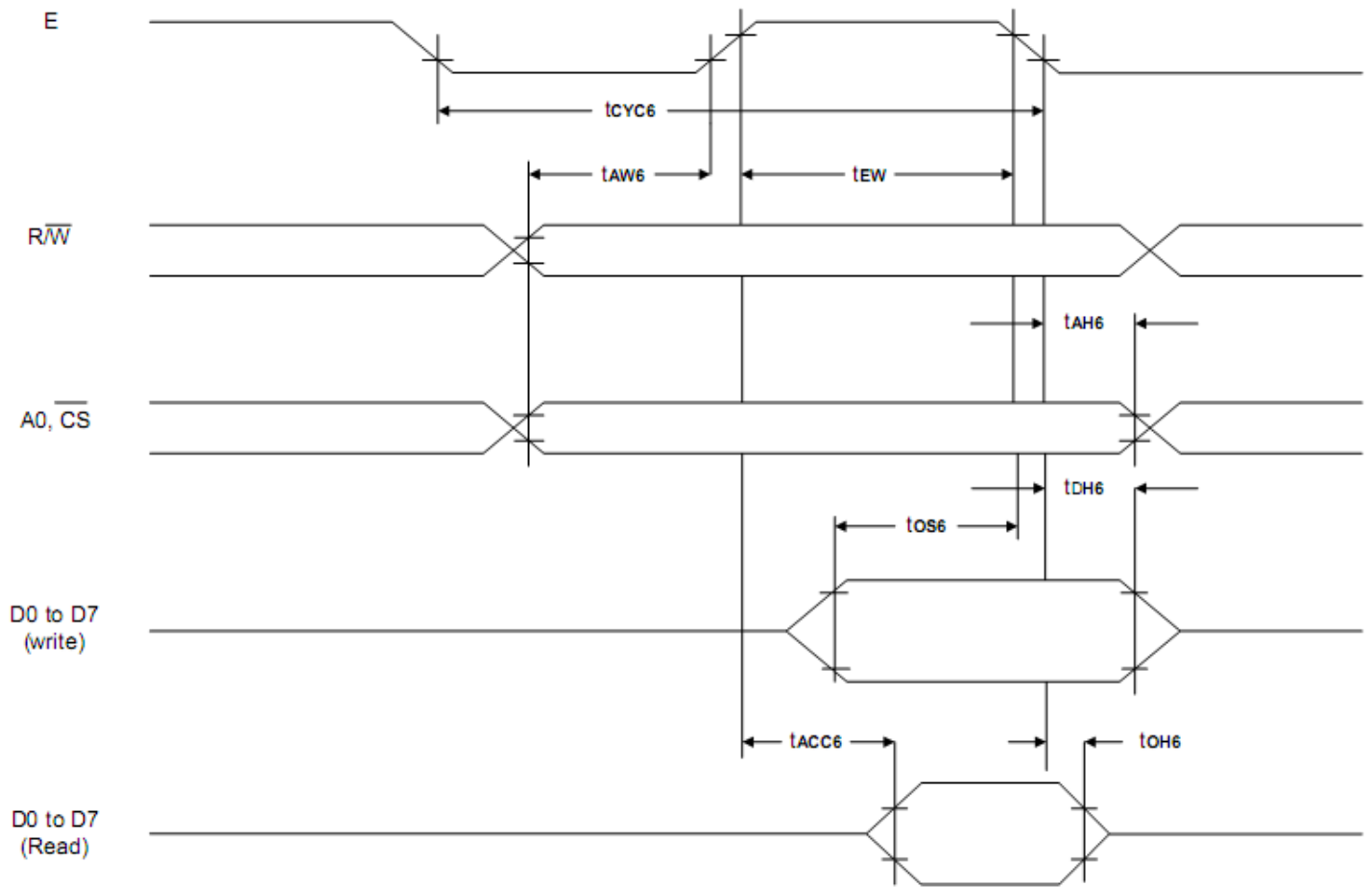

Ta = -20 to 75°C

Signal	Symbol	Parameter	V _{DD} = 4.5 to 5.5V		V _{DD} = 2.7 to 4.5V		Unit	Condition
			Min.	Max.	Min.	Max.		
A0, \overline{CS} , R/(W)	t _{CYC6}	System cycle time	note.	—	note.	—	ns	CL = 100 pF
	t _{AW6}	Address setup time	0	—	10	—	ns	
	t _{AH6}	Address hold time	0	—	0	—	ns	
D0 to D7	t _{DS6}	Data setup time	100	—	120	—	ns	
	t _{DH6}	Data hold time	0	—	0	—	ns	
	t _{OH6}	Output disable time	10	50	10	75	ns	
	t _{ACC6}	Access time	—	85	—	130	ns	
E	t _{EW}	Enable pulse width	120	—	150	—	ns	

Display Memory Read Timing

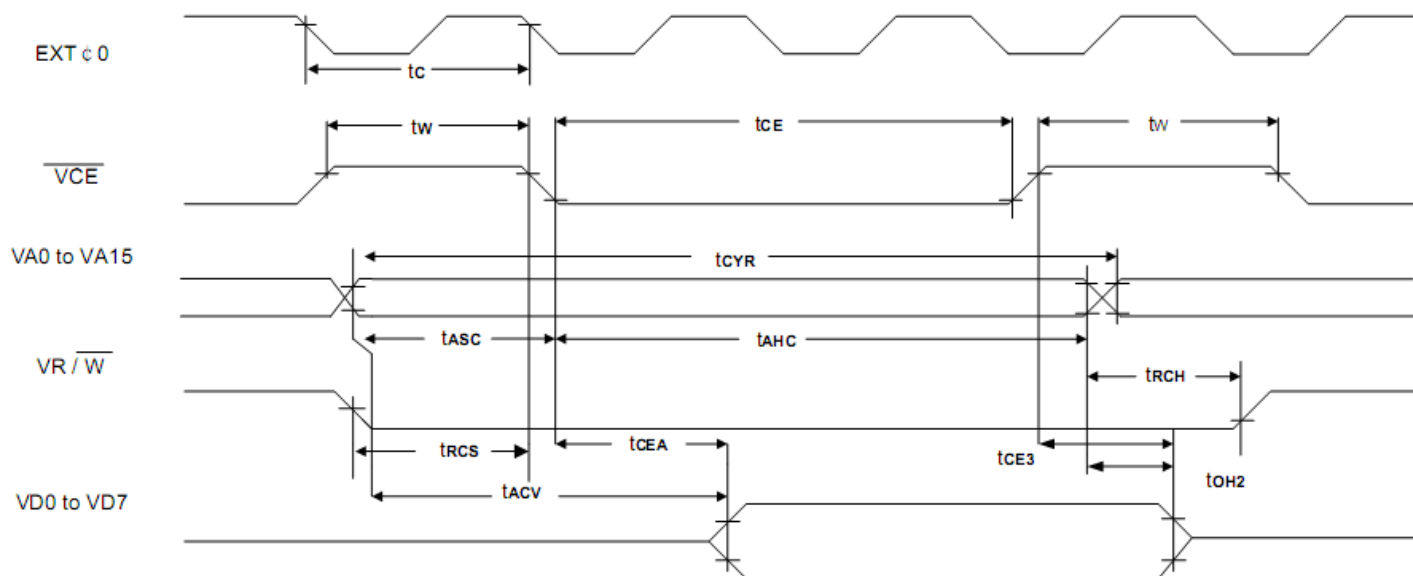

Ta = -20 to 75°C

Signal	Symbol	Parameter	V _{DD} = 4.5 to 5.5V		V _{DD} = 2.7 to 4.5V		Unit	Condition
			Min.	Max.	Min.	Max.		
EXT Φ0	t _C	Clock period	100	—	125	—	ns	CL = 100 pF
$\overline{\text{VCE}}$	t _w	VCE HIGH-level pulse width	t _C - 50	—	t _C - 50	—	ns	
	t _{CE}	VCE LOW-level pulse width	2t _C - 30	—	2t _C - 30	—	ns	
VA0 to VA15	t _{CYR}	Read cycle time	3t _C	—	3t _C	—	ns	
	t _{ASC}	Address setup time to falling edge of $\overline{\text{VCE}}$	t _C - 70	—	t _C - 100	—	ns	
	t _{AHC}	Address hold time from falling edge of $\overline{\text{VCE}}$	2t _C - 30	—	2t _C - 40	—	ns	
$\overline{\text{VRD}}$	t _{RCS}	Read cycle setup time to falling edge of $\overline{\text{VCE}}$	t _C - 45	—	t _C - 60	—	ns	
	t _{RCH}	Read cycle hold time from rising edge of $\overline{\text{VCE}}$	0.5t _C	—	0.5t _C	—	ns	
VD0 to VD7	t _{ACV}	Address access time	—	3t _C - 100	—	3t _C - 115	Ns	
	t _{CEA}	VCE access time	—	2t _C - 80	—	2t _C - 90	Ns	
	t _{OH2}	Output data hold time	0	—	0	—	ns	
	t _{CE3}	VCE to data off time	0	—	0	—	ns	

Display Memory Write Timing

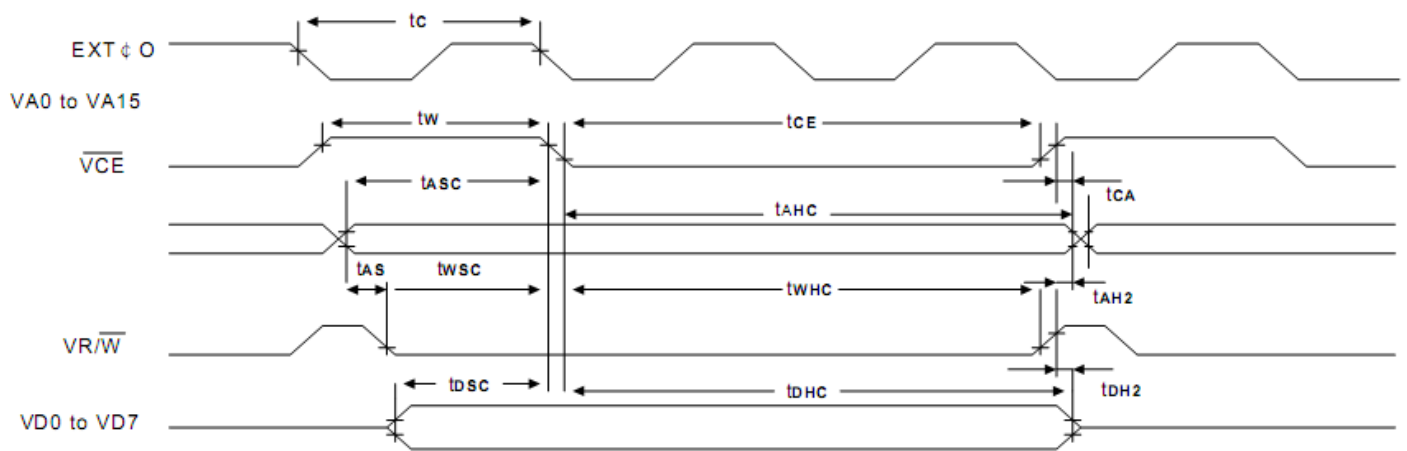

Ta = -20 to 75°C

Signal	Symbol	Parameter	V _{DD} = 4.5 to 5.5V		V _{DD} = 2.7 to 4.5V		Unit	Condition
			Min.	Max.	Min.	Max.		
EXT Φ0	t _c	Clock period	100	—	125	—	ns	CL = 100 pF
$\overline{\text{VCE}}$	t _w	VCE HIGH-level pulse width	t _c - 50	—	t _c - 50	—	ns	
	t _{ce}	VCE LOW-level pulse width	2t _c - 30	—	2t _c - 30	—	ns	
VA0 to VA15	t _{cyw}	Write cycle time	3t _c	—	3t _c	—	ns	
	t _{AHC}	Address hold time from falling edge of $\overline{\text{VCE}}$	2t _c - 30	—	2t _c - 40	—	ns	
	t _{ASC}	Address setup time to falling edge of $\overline{\text{VCE}}$	t _c - 70	—	t _c - 110	—	ns	
	t _{CA}	Address hold time from rising edge of $\overline{\text{VCE}}$	0	—	0	—	ns	
	t _{AS}	Address setup time to falling edge of $\overline{\text{VWR}}$	0	—	0	—	ns	
	t _{AH2}	Address hold time from rising edge of $\overline{\text{VWR}}$	10	—	10	—	ns	
$\overline{\text{VWR}}$	t _{wsc}	Write setup time to falling edge of $\overline{\text{VCE}}$	t _c - 80	—	t _c - 115	—	ns	
	t _{whc}	Write hold time from falling edge of $\overline{\text{VCE}}$	2t _c - 20	—	2t _c - 20	—	ns	
VD0 to VD7	t _{dsc}	Data input setup time to falling edge of $\overline{\text{VCE}}$	t _c - 85	—	t _c - 125	—	ns	
	t _{dhc}	Data input hold time from falling edge of $\overline{\text{VCE}}$	2t _c - 30	—	2t _c - 30	—	ns	

Example Initialization Program

```
//-----  
sbit A0 = P3^0;  
sbit RW = P3^7;  
sbit E = P3^4;  
sbit CS = P3^1;  
sbit IM = P3^6;  
sbit RST = P3^2;  
  
//-----  
void Writecom(int A)  
{  
    CS = 0;  
    RW = 0;  
    A0 = 1;  
    E = 1;  
    P1 = A;  
    E = 1;  
}  
  
void Write(int A)  
{  
    CS = 0;  
    RW = 0;  
    A0 = 0;  
    E = 1;  
    P1 = A;  
    E = 1;  
}  
  
//-----  
void init()  
{  
    IM = 1;  
    RST = 0;  
    delay(10);  
    RST = 1;  
    delay(100);  
    Writecom(0x40);  
    Write(0x30);  
    Write(0x87);  
    Write(0x07);  
    Write(0x1D);  
    Write(0x50);  
    Write(0x80);  
    Write(0x1E);  
    Write(0x00);  
    Writecom(0x44);  
    Write(0x00);  
    Write(0x00);  
    Write(0x80);  
    Write(0x00);  
    Write(0x40);  
    Write(0x80);  
    Write(0x00);  
    Write(0x00);  
    Write(0x00);  
    Write(0x00);  
    Write(0x5A);  
    Write(0x00);  
    Write(0x5B);  
    Write(0x0C);  
    Write(0x4C);  
    Write(0x46);  
}
```

```
Write(0xB0);
Write(0xB0);
Write(0x42);
Write(0x00);

for(a = 0; a < 3840; a++)
{
    Write(0x00);
}
Writecom(0x46);
Write(0x60);
Write(0x09);
Writecom(0x42);
Write(0x00);
for(a = 0; a < 3840; a++)
{
    Write(0x00);
}
Writecom(0x59);
Write(0x04);
}
//-----
```

Quality Information

Test Item	Content of Test	Test Condition	Note
High Temperature storage	Endurance test applying the high storage temperature for a long time.	+80°C , 200hrs	2
Low Temperature storage	Endurance test applying the low storage temperature for a long time.	-30°C , 200hrs	1,2
High Temperature Operation	Endurance test applying the electric stress (voltage & current) and the high thermal stress for a long time.	+70°C 200hrs	2
Low Temperature Operation	Endurance test applying the electric stress (voltage & current) and the low thermal stress for a long time.	-20°C , 200hrs	1,2
High Temperature / Humidity Operation	Endurance test applying the electric stress (voltage & current) and the high thermal with high humidity stress for a long time.	+60°C , 90% RH , 96hrs	1,2
Thermal Shock resistance	Endurance test applying the electric stress (voltage & current) during a cycle of low and high thermal stress.	-20°C,30min -> 25°C,5min -> 70°C,30min = 1 cycle 10 cycles	
Vibration test	Endurance test applying vibration to simulate transportation and use.	10-55Hz , 15mm amplitude. 60 sec in each of 3 directions X,Y,Z For 15 minutes	3
Static electricity test	Endurance test applying electric static discharge.	VS=800V, RS=1.5kΩ, CS=100pF One time	

Note 1: No condensation to be observed.

Note 2: Conducted after 4 hours of storage at 25°C, 0%RH.

Note 3: Test performed on product itself, not inside a container.

Precautions for using LCDs/LCMs

See Precautions at www.newhavendisplay.com/specs/precautions.pdf

Warranty Information and Terms & Conditions

http://www.newhavendisplay.com/index.php?main_page=terms