

# NHD-C12832A1Z-FS(RGB)-FBW-3V

## COG (Chip-On-Glass) Liquid Crystal Display Module

NHD-	Newhaven Display
C12832-	128 x 32 pixels
A1Z-	Model
F-	Transflective
SRGB-	Side Red/Green/Blue LED Backlight
F-	FSTN (+)
B-	6:00 view
W-	Wide Temp (-20°C ~ +70°C)
3V-	3Vdd
	<b>RoHS Compliant</b>

**Newhaven Display International, Inc.**

2511 Technology Drive, Suite 101

Elgin IL, 60124

Ph: 847-844-8795

Fax: 847-844-8796

[www.newhavendisplay.com](http://www.newhavendisplay.com)

[nhtech@newhavendisplay.com](mailto:nhtech@newhavendisplay.com)

[nhsales@newhavendisplay.com](mailto:nhsales@newhavendisplay.com)

## Document Revision History

Revision	Date	Description	Changed by
0	10/23/2012	Initial Release	AK

## Functions and Features

- 128 x 32 pixels
- 4-line SPI MPU interfaces
- Built-in ST7565R controller
- +3.0V power supply
- 1/33 duty cycle; 1/6 bias
- RoHS Compliant

# Mechanical Drawing

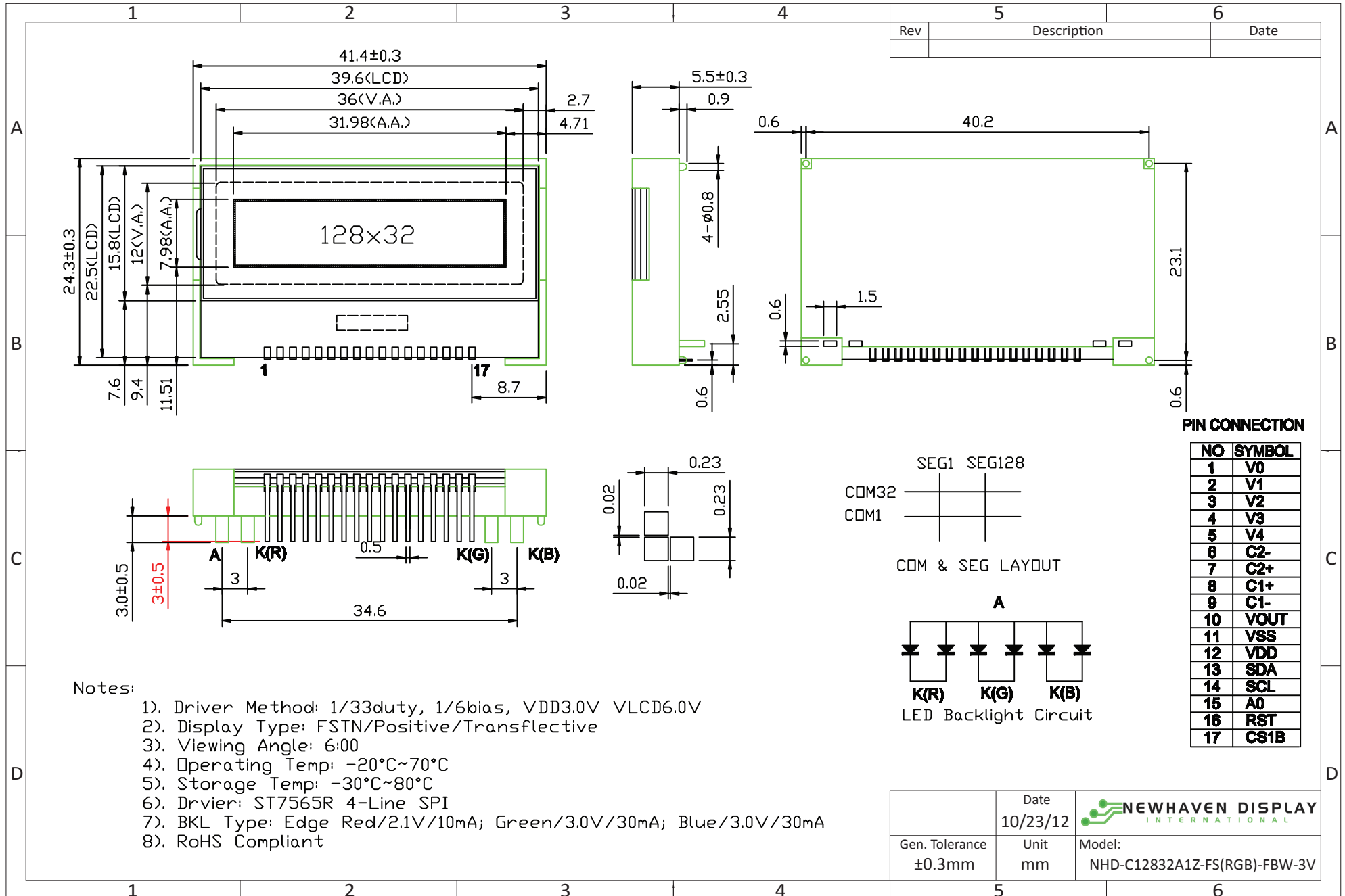

## Pin Description and Wiring Diagram

Pin No.	Symbol	External Connection	Function Description
1	V0	Power Supply	0.47uF-2.2uF Cap to VSS
2	V1	Power Supply	0.47uF -2.2uF Cap to VSS
3	V2	Power Supply	0.47uF -2.2uF Cap to VSS
4	V3	Power Supply	0.47uF -2.2uF Cap to VSS
5	V4	Power Supply	0.47uF 2.2uF Cap to VSS
6	C2-	Power Supply	Connect to 1uF Cap to C2+ (pin 7)
7	C2+	Power Supply	Connect to 1uF Cap to C2- (pin 6)
8	C1+	Power Supply	Connect to 1uF Cap to C1- (pin 9)
9	C1-	Power Supply	Connect to 1uF Cap to C1+ (pin 8)
10	VOUT	Power Supply	Connect to 1uF cap to VSS (pin 11)
11	VSS	Power Supply	Ground
12	VDD	Power Supply	Power supply for LCD and logic (+3V)
13	SDA(SI)	MPU	Serial data
14	SCL	MPU	Serial clock
15	A0	MPU	Select registers. 0: instruction, 1: data register
16	RST	MPU	External reset PIN. Must be fixed to VDD low active.
17	CS1B	MPU	Chip select in serial interface low active
A	LED+	Power Supply	Power supply for LED Backlight
K(R)	(R)LED-	Power Supply	Ground for Red LED Backlight
K(G)	(G)LED-	Power Supply	Ground for Green LED Backlight
K(B)	(B)LED-	Power Supply	Ground for Blue LED Backlight

**Recommended LCD connector:** 1.5mm pitch pins, solder directly into PCB

**Backlight connector:** 1.5mm wide pins solder directly into PCB **Mates with:** ---

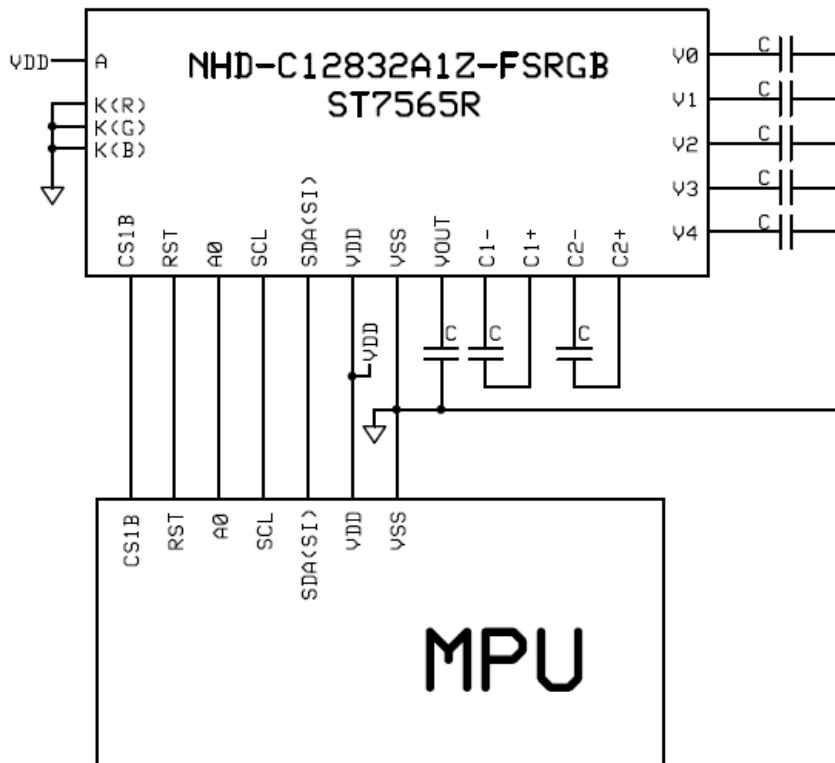

## Electrical Characteristics

Item	Symbol	Condition	Min.	Typ.	Max.	Unit
Operating Temperature Range	Top	Absolute Max	-20	-	+70	°C
Storage Temperature Range	Tst	Absolute Max	-30	-	+80	°C
Supply Voltage	VDD		2.7	3.0	3.3	V
Supply Current	IDD	Ta=25°C, VDD=3.0V	-	0.25	0.45	mA
Supply for LCD (contrast)	VDD-V0	Ta=25°C	-	6.0	-	V
"H" Level input	Vih		2.2	-	VDD	V
"L" Level input	Vil		0	-	0.6	V
"H" Level output	Voh		2.4	-	-	V
"L" Level output	Vol		-	-	0.4	V
Backlight supply voltage – Red			1.8	2.1	2.2	V
Backlight supply current – Red			-	10	40	mA
Backlight supply voltage – Green			2.8	3.0	3.3	V
Backlight supply current – Green			-	30	60	mA
Backlight supply voltage – Blue			2.8	3.0	3.3	V
Backlight supply current – Blue			-	30	60	mA

## Optical Characteristics

Item	Symbol	Condition	Min.	Typ.	Max.	Unit
Viewing Angle – Top		Cr≥2	-	35	-	°
Viewing Angle – Bottom			-	60	-	°
Viewing Angle – Left			-	40	-	°
Viewing Angle – Right			-	40	-	°
Contrast Ratio	CR		-	6	-	-
Response Time (rise)	Tr	-	-	150	250	ms
Response Time (fall)	Tf	-	-	150	250	ms

## Controller Information

Built-in ST7565R controller.

Please download specification at [http://www.newhavendisplay.com/app\\_notes/ST7565R.pdf](http://www.newhavendisplay.com/app_notes/ST7565R.pdf)

# Timing Characteristics

## The 4-line SPI Interface

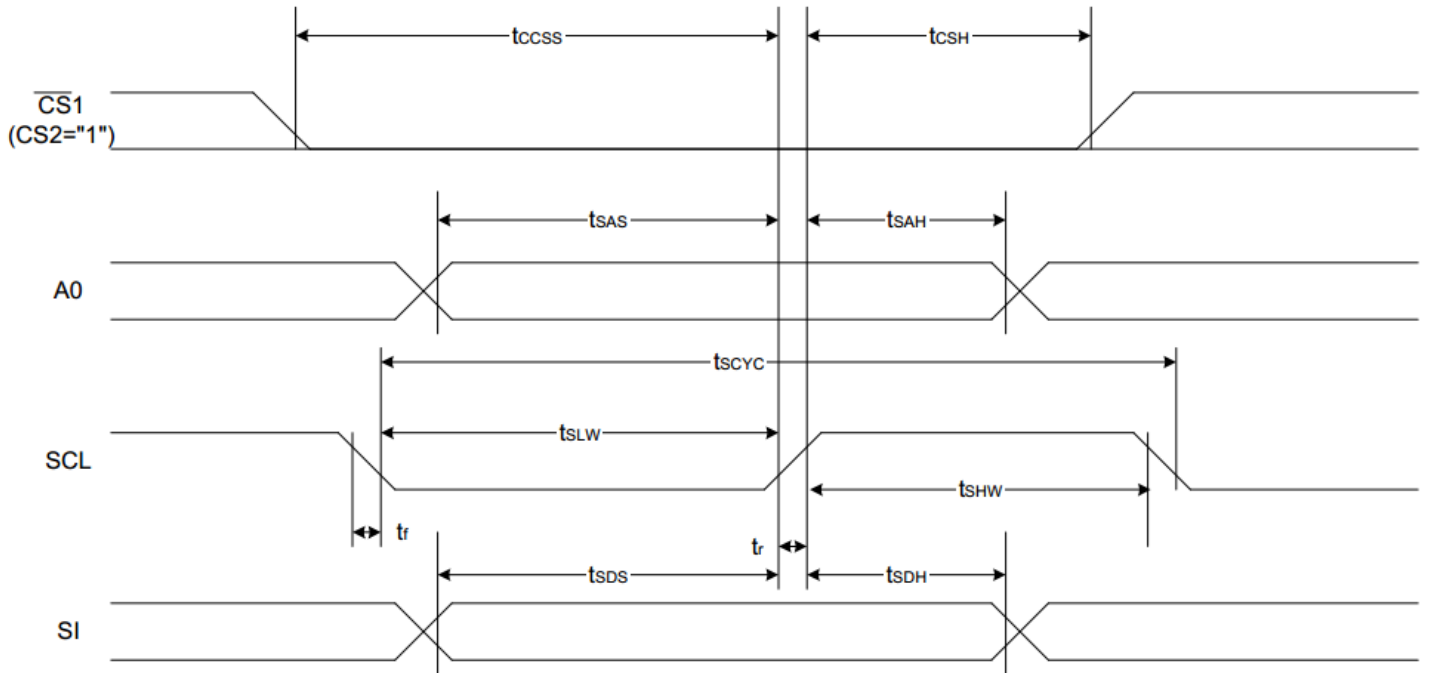

( $V_{DD} = 3.3V, T_a = -30$  to  $85^\circ C$ )

Item	Signal	Symbol	Condition	Rating		Units
				Min.	Max.	
4-line SPI Clock Period	SCL	$T_{scyc}$		50	—	ns
SCL "H" pulse width		$T_{shw}$		25	—	
SCL "L" pulse width		$T_{SLW}$		25	—	
Address setup time	A0	$T_{SAS}$		20	—	
Address hold time		$T_{SAH}$		10	—	
Data setup time	SI	$T_{SDS}$		20	—	
Data hold time		$T_{SDH}$		10	—	
CS-SCL time	CS	$T_{CSS}$		20	—	
CS-SCL time		$T_{CSH}$		40	—	

## Table of Commands

Command	Command Code										Function		
	A0	/RD	/WR	D7	D6	D5	D4	D3	D2	D1		D0	
(1) Display ON/OFF	0	1	0	1	0	1	0	1	1	1	0	1	LCD display ON/OFF 0: OFF, 1: ON
(2) Display start line set	0	1	0	0	1	Display start address					0	Sets the display RAM display start line address	
(3) Page address set	0	1	0	1	0	1	Page address					0	Sets the display RAM page address
(4) Column address set upper bit	0	1	0	0	0	0	1	Most significant column address				0	Sets the most significant 4 bits of the display RAM column address.
Column address set lower bit				0	0	0	0	Least significant column address					Sets the least significant 4 bits of the display RAM column address.
(5) Status read	0	0	1	Status				0	0	0	0	0	Reads the status data
(6) Display data write	1	1	0	Write data							0	Writes to the display RAM	
(7) Display data read	1	0	1	Read data							0	Reads from the display RAM	
(8) ADC select	0	1	0	1	0	1	0	0	0	0	0	1	Sets the display RAM address SEG output correspondence 0: normal, 1: reverse
(9) Display normal/reverse	0	1	0	1	0	1	0	0	1	1	0	1	Sets the LCD display normal/ reverse 0: normal, 1: reverse
(10) Display all points ON/OFF	0	1	0	1	0	1	0	0	1	0	0	1	Display all points 0: normal display 1: all points ON
(11) LCD bias set	0	1	0	1	0	1	0	0	0	1	0	1	Sets the LCD drive voltage bias ratio 0: 1/9 bias, 1: 1/7 bias (ST7565R)
(12) Read-modify-write	0	1	0	1	1	1	0	0	0	0	0	0	Column address increment At write: +1 At read: 0
(13) End	0	1	0	1	1	1	0	1	1	1	0	0	Clear read/modify/write
(14) Reset	0	1	0	1	1	1	0	0	0	1	0	0	Internal reset
(15) Common output mode select	0	1	0	1	1	0	0	0	*	*	*	1	Select COM output scan direction 0: normal direction 1: reverse direction
(16) Power control set	0	1	0	0	0	1	0	1	Operating mode		0	0	Select internal power supply operating mode
(17) V <sub>O</sub> voltage regulator internal resistor ratio set	0	1	0	0	0	1	0	0	Resistor ratio		0	0	Select internal resistor ratio(Rb/Ra) mode
(18) Electronic volume mode set	0	1	0	1	0	0	0	0	0	0	0	1	Set the V <sub>O</sub> output voltage electronic volume register
Electronic volume register set				0	0	Electronic volume value							
(19) Sleep mode set	0	1	0	1	0	1	0	1	1	0	0	1	0: Sleep mode, 1: Normal mode
(20) Booster ratio set	0	1	0	1	1	1	1	1	0	0	0	0	select booster ratio 00: 2x,3x,4x 01: 5x 11: 6x
				0	0	0	0	0	0	0	step-up value		
(21) NOP	0	1	0	1	1	1	0	0	0	1	1	0	Command for non-operation
(22) Test	0	1	0	1	1	1	1	*	*	*	*	*	Command for IC test. Do not use this command

## Example Initialization Program

```
void data_out(unsigned char i) //Data Output Serial Interface
{
    unsigned int n;
    CS = 0;
    A0 = 1;
    for(n=0; n<8; n++){
        i <<=1;
        SCL = 0;
        P1 = i;
        delay(2);
        SCL = 1;
    }
    CS = 1;
}

void comm_out(unsigned char j) //Command Output Serial Interface
{
    unsigned int n;
    CS = 0;
    A0 = 0;
    for(n=0; n<8; n++){
        j <<=1;
        SCL = 0;
        P1 = j;
        delay(2);
        SCL = 1;
    }
    CS = 1;
}

/*****
*      Initialization For controller      *
*****/

void init_LCD()
{
    comm_out(0xA0);
    comm_out(0xAE);
    comm_out(0xC0);
    comm_out(0xA2);
    comm_out(0x2F);
    comm_out(0x26);
    comm_out(0x81);
    comm_out(0x2F);
}

/*****/
```



## Quality Information

Test Item	Content of Test	Test Condition	Note
High Temperature storage	Endurance test applying the high storage temperature for a long time.	+80°C , 48hrs	2
Low Temperature storage	Endurance test applying the low storage temperature for a long time.	-30°C , 48hrs	1,2
High Temperature Operation	Endurance test applying the electric stress (voltage & current) and the high thermal stress for a long time.	+70°C 48hrs	2
Low Temperature Operation	Endurance test applying the electric stress (voltage & current) and the low thermal stress for a long time.	-20°C , 48hrs	1,2
High Temperature / Humidity Operation	Endurance test applying the electric stress (voltage & current) and the high thermal with high humidity stress for a long time.	+40°C , 90% RH , 48hrs	1,2
Thermal Shock resistance	Endurance test applying the electric stress (voltage & current) during a cycle of low and high thermal stress.	-0°C,30min -> 25°C,5min -> 50°C,30min = 1 cycle 10 cycles	
Vibration test	Endurance test applying vibration to simulate transportation and use.	10-55Hz , 15mm amplitude. 60 sec in each of 3 directions X,Y,Z For 15 minutes	3
Static electricity test	Endurance test applying electric static discharge.	VS=800V, RS=1.5kΩ, CS=100pF One time	

**Note 1:** No condensation to be observed.

**Note 2:** Conducted after 4 hours of storage at 25°C, 0%RH.

**Note 3:** Test performed on product itself, not inside a container.

## Precautions for using LCDs/LCMs

See Precautions at [www.newhavendisplay.com/specs/precautions.pdf](http://www.newhavendisplay.com/specs/precautions.pdf)

## Warranty Information and Terms & Conditions

[http://www.newhavendisplay.com/index.php?main\\_page=terms](http://www.newhavendisplay.com/index.php?main_page=terms)