

NHD-C12864A1Z-FSB-FBW-HTT

COG (Chip-On-Glass) Liquid Crystal Display Module

NHD-	Newhaven Display
C12864-	128 x 64 pixels
A1Z-	Model
F-	Transflective
SB-	Side Blue LED backlight
F-	FSTN (+)
B-	6:00 view
W-	Wide Temp (-20°C ~ +70°C)
HTT-	With 12V Heater (-40°C ~ +70°C)
	RoHS Compliant

Newhaven Display International, Inc.

2511 Technology Drive, Suite 101

Elgin IL, 60124

Ph: 847-844-8795

Fax: 847-844-8796

www.newhavendisplay.com

nhtech@newhavendisplay.com

nhsales@newhavendisplay.com

Document Revision History

Revision	Date	Description	Changed by
0	10/20/2010	Initial Release	-
1	10/26/2010	Pin Length Adjusted from 0.5" to 0.3" on Drawing	MC
2	10/27/2010	Supply Current and block diagram updated	BE
3	1/20/2011	Operating Temp updated	BE
4	8/31/2011	Electrical characteristics updated	AK
5	7/30/2012	Electrical characteristics updated	AK

Functions and Features

- 128 x 64 pixels
- Built-in ST7565P controller
- +3.3V power supply
- 1/65 duty cycle; 1/9 bias
- Built-in Heater
- RoHS Compliant

Mechanical Drawing

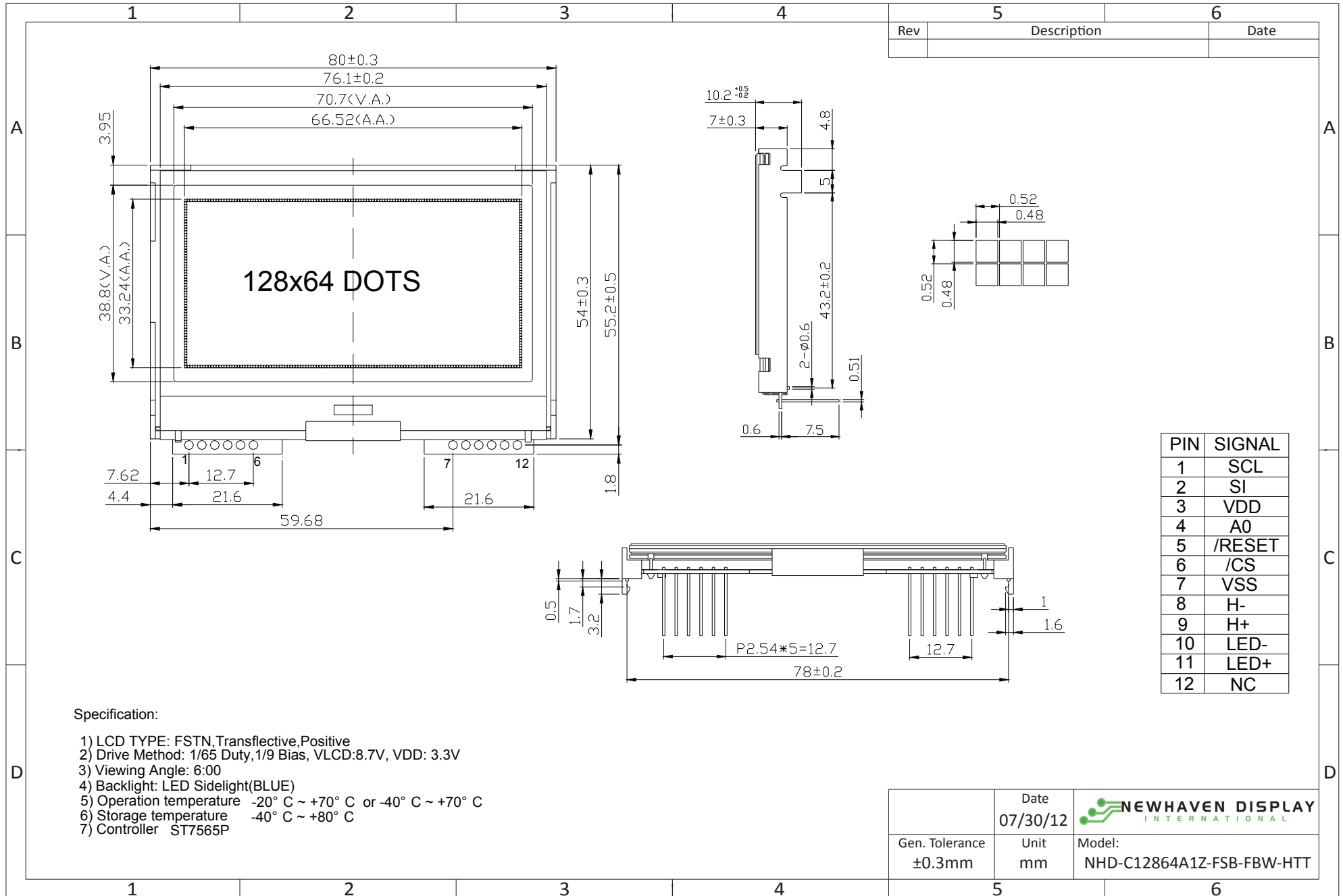

Pin Description and Wiring Diagram

Pin No.	Symbol	External Connection	Function Description
1	SCL	MPU	Serial clock input
2	SI	MPU	Serial data input
3	VDD	Power Supply	Power supply for LCD and logic (+3.3V)
4	A0	MPU	Register Select. 0: instruction; 1: data
5	/RESET	MPU	Operation Active LOW Reset signal
6	/CS	MPU	Active LOW Chip Select Signal
7	Vss	Power Supply	Ground
8	H-	Power Supply	Ground for Heater
9	H+	Power Supply	Power for Heater (+12V)
10	LED-	Power Supply	Ground for backlight
11	LED+	Power Supply	Power supply for LED backlight (+3.3V)
12	NC	-	No Connect

Recommended LCD connector: 2.54mm Pitch pins.

Backlight connector: --- Mates with: ---

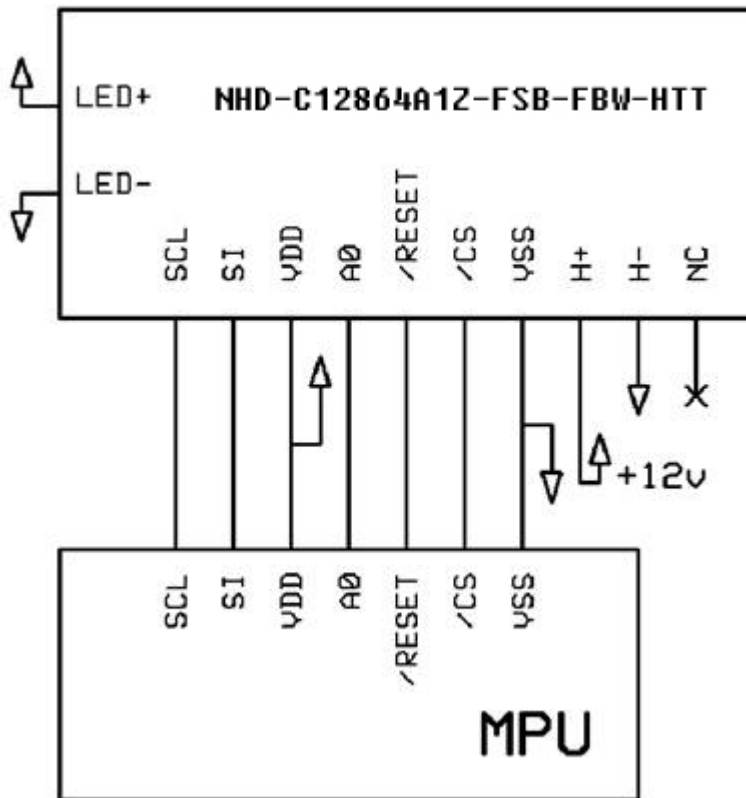

Electrical Characteristics

Item	Symbol	Condition	Min.	Typ.	Max.	Unit
Operating Temperature Range	TOP	Absolute Max	-40	-	+70	°C
Storage Temperature Range	TST	Absolute Max	-30	-	+80	°C
Supply Voltage	VDD		2.4	3.3	3.3	V
Supply Current	IDD	Ta=25°C, VDD=3.3V	-	0.5	-	mA
Supply for LCD (contrast)	VDD-V0	Ta=25°C	8.3	8.7	9.3	V
"H" Level input	Vih		2.2	-	VDD	V
"L" Level input	Vil		0	-	0.6	V
"H" Level output	Voh		2.4	-	-	V
"L" Level output	Vol		-	-	0.4	V
Backlight Supply Voltage	VLED		-	3.3	-	V
Backlight Supply Current	ILED	VLED=3.3V	-	50	60	mA
Heater panel resistance	RH+/-		-	20	25	Ω
Heater Voltage Supply	VH		-	12V	-	V
Heater Current	IH	VH=12.0V	-	1	-	A
Heater Power	WH				10	W

Optical Characteristics

Item	Symbol	Condition	Min.	Typ.	Max.	Unit
Viewing Angle - Vertical	K	CR ≥ 3	-20	-	+40	°
Viewing Angle - Horizontal	Φ	CR ≥ 3	-35	-	+35	°
Contrast Ratio	CR		-	10	-	-
Response Time (rise)	Tr		-	200	250	ms
Response Time (fall)	Tf		-	300	350	ms

Heater Circuit Example:

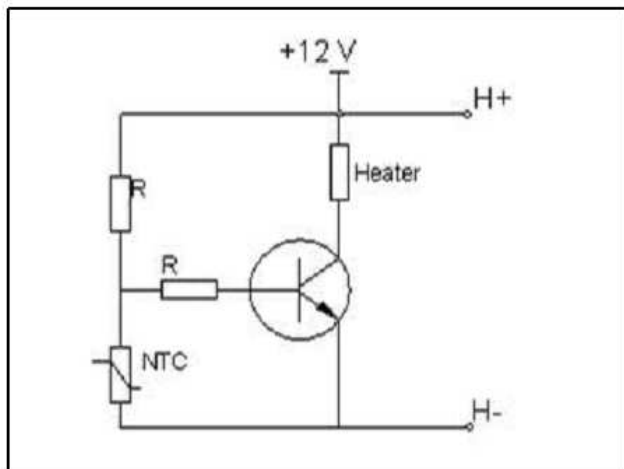

Controller Information

Built-in ST7565P. Download specification at http://www.newhavendisplay.com/app_notes/ST7565.pdf

Timing Characteristics

The Serial Interface

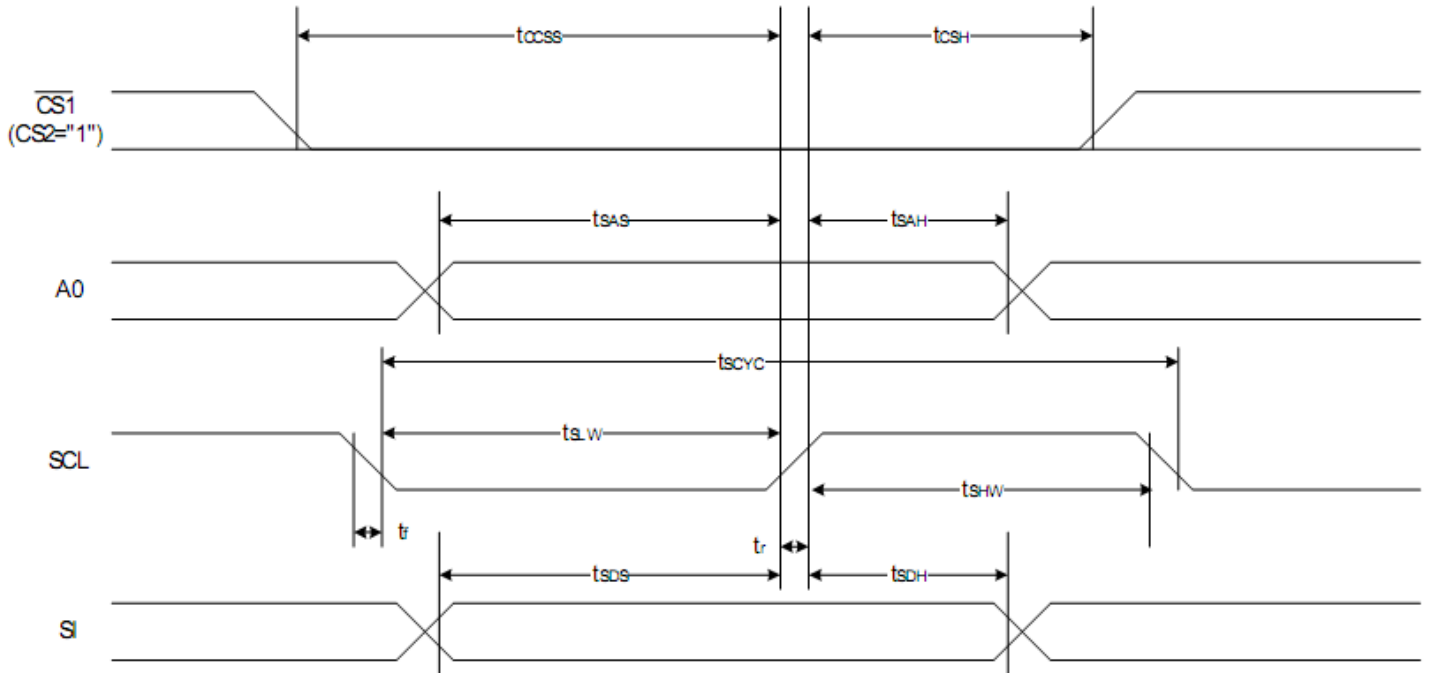

Item	Signal	Symbol	Condition	Rating		Units
				Min.	Max.	
Serial Clock Period	SCL	t_{SCYC}		400	—	ns
SCL "H" pulse width		t_{SHW}		120	—	
SCL "L" pulse width		t_{SLW}		120	—	
Address setup time	A0	t_{SAS}		50	—	
Address hold time		t_{SAH}		50	—	
Data setup time	SI	t_{SDS}		50	—	
Data hold time		t_{SDH}		50	—	
CS-SCL time	CS	t_{CSS}		50	—	
CS-SCL time		t_{CSH}		150	—	

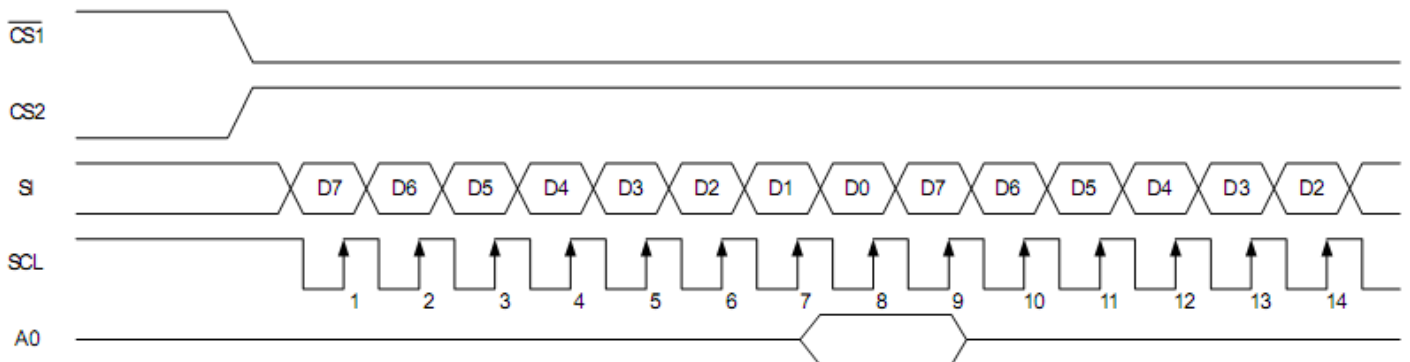

Table of Commands

Command	Command Code									Function			
	A0	/RD	/WR	D7	D6	D5	D4	D3	D2		D1	D0	
(1) Display ON/OFF	0	1	0	1	0	1	0	1	1	1	0	1	LCD display ON/OFF 0: OFF, 1: ON
(2) Display start line set	0	1	0	0	1	Display start address						Sets the display RAM display start line address	
(3) Page address set	0	1	0	1	0	1	1	Page address				Sets the display RAM page address	
(4) Column address set upper bit	0	1	0	0	0	0	1	Most significant column address				Sets the most significant 4 bits of the display RAM column address.	
Column address set lower bit	0	1	0	0	0	0	0	Least significant column address				Sets the least significant 4 bits of the display RAM column address.	
(5) Status read	0	0	1	Status				0	0	0	0	0	Reads the status data
(6) Display data write	1	1	0	Write data								Writes to the display RAM	
(7) Display data read	1	0	1	Read data								Reads from the display RAM	
(8) ADC select	0	1	0	1	0	1	0	0	0	0	0	1	Sets the display RAM address SEG output correspondence 0: normal, 1: reverse
(9) Display normal/reverse	0	1	0	1	0	1	0	0	1	1	0	1	Sets the LCD display normal/reverse 0: normal, 1: reverse
(10) Display all points ON/OFF	0	1	0	1	0	1	0	0	1	0	0	1	Display all points 0: normal display 1: all points ON
(11) LCD bias set	0	1	0	1	0	1	0	0	0	1	0	1	Sets the LCD drive voltage bias ratio 0: 1/9 bias, 1: 1/7 bias (ST7565)
(12) Read/modify/write	0	1	0	1	1	1	0	0	0	0	0	0	Column address increment At write: +1 At read: 0
(13) End	0	1	0	1	1	1	0	1	1	1	0	0	Clear read/modify/write
(14) Reset	0	1	0	1	1	1	0	0	0	1	0	0	Internal reset
(15) Common output mode select	0	1	0	1	1	0	0	0	*	*	*	*	Select COM output scan direction 0: normal direction 1: reverse direction
(16) Power control set	0	1	0	0	0	1	0	1	Operating mode			Select internal power supply operating mode	
(17) Vs voltage regulator internal resistor ratio set	0	1	0	0	0	1	0	0	Resistor ratio			Select internal resistor ratio(Rb/Ra) mode	
(18) Electronic volume mode set	0	1	0	1	0	0	0	0	0	0	0	1	Set the Vs output voltage electronic volume register
Electronic volume register set				0	0	Electronic volume value							
(19) Static indicator ON/OFF	0	1	0	1	0	1	0	1	1	0	0	0	0: OFF, 1: ON
Static indicator register set				0	0	0	0	0	0	0	Mode	1	Set the flashing mode
(20) Power saver													Display OFF and display all points ON compound command
(21) NOP	0	1	0	1	1	1	0	0	0	1	1	1	Command for non-operation
(22) Test	0	1	0	1	1	1	1	*	*	*	*	*	Command for IC test. Do not use this command

Example Initialization Program

```
.....  
Sub Command  
Reset P3.7  
Reset P3.4  
For Writecount = 1 To 8  
Rotate A , Left , 1  
Reset P3.1  
P1 = A  
Set P3.1  
Next Writecount  
Set P3.7  
End Sub  
.....
```

```
Sub Write  
Reset P3.7  
Set P3.4  
For Writecount = 1 To 8  
Rotate A , Left , 1  
Reset P3.1  
P1 = A  
Set P3.1  
Next Writecount  
Set P3.7  
End Sub  
.....
```

```
Sub Init  
Waitms 100  
A = &HA0  
Call Command  
A = &HAE  
Call Command  
A = &HC0  
Call Command  
A = &HA2  
Call Command  
A = &H2F  
Call Command  
A = &H26  
Call Command  
A = &H81  
Call Command  
A = &H11  
Call Command  
A = &HAF  
Call Command  
End Sub  
.....
```

Quality Information

Test Item	Content of Test	Test Condition	Note
High Temperature storage	Endurance test applying the high storage temperature for a long time.	+80°C , 48hrs	2
Low Temperature storage	Endurance test applying the low storage temperature for a long time.	-30°C , 48hrs	1,2
High Temperature Operation	Endurance test applying the electric stress (voltage & current) and the high thermal stress for a long time.	+70°C 48hrs	2
Low Temperature Operation	Endurance test applying the electric stress (voltage & current) and the low thermal stress for a long time.	-20°C , 48hrs	1,2
High Temperature / Humidity Operation	Endurance test applying the electric stress (voltage & current) and the high thermal with high humidity stress for a long time.	+40°C , 90% RH , 48hrs	1,2
Thermal Shock resistance	Endurance test applying the electric stress (voltage & current) during a cycle of low and high thermal stress.	-0°C,30min -> 25°C,5min -> 50°C,30min = 1 cycle 10 cycles	
Vibration test	Endurance test applying vibration to simulate transportation and use.	10-55Hz , 15mm amplitude. 60 sec in each of 3 directions X,Y,Z For 15 minutes	3
Static electricity test	Endurance test applying electric static discharge.	VS=800V, RS=1.5kΩ, CS=100pF One time	

Note 1: No condensation to be observed.

Note 2: Conducted after 4 hours of storage at 25°C, 0%RH.

Note 3: Test performed on product itself, not inside a container.

Precautions for using LCDs/LCMs

See Precautions at www.newhavendisplay.com/specs/precautions.pdf

Warranty Information and Terms & Conditions

http://www.newhavendisplay.com/index.php?main_page=terms