

# NHD-C12864GG-RN-GBW

## COG (Chip-On-Glass) Liquid Crystal Display Module

NHD- Newhaven Display  
C12864- 128 x 64 Pixels  
GG- Model  
R- Reflective  
N- No Backlight  
G- STN - Gray  
B- 6:00 Optimal View  
W- Wide Temperature  
**RoHS Compliant**

**Newhaven Display International, Inc.**

2511 Technology Drive, Suite 101

Elgin IL, 60124

Ph: 847-844-8795

Fax: 847-844-8796

[www.newhavendisplay.com](http://www.newhavendisplay.com)

[nhtech@newhavendisplay.com](mailto:nhtech@newhavendisplay.com)

[nhsales@newhavendisplay.com](mailto:nhsales@newhavendisplay.com)

## Document Revision History

Revision	Date	Description	Changed by
0	3/25/2008	Initial Release	-
1	9/10/2009	User guide reformat	BE
2	10/8/2009	Update pin description	BE
3	10/13/2009	Updated Electrical Characteristic	MC
4	10/9/2013	Mechanical Drawing, Pin Description, Electrical/Optical Characteristics, Example Code updated	ML

## Functions and Features

- 128 x 64 pixels
- Built-in ST7565R controller
- 1/65 duty, 1/9 bias
- Parallel 8080 MPU interface
- RoHS Compliant

# Mechanical Drawing

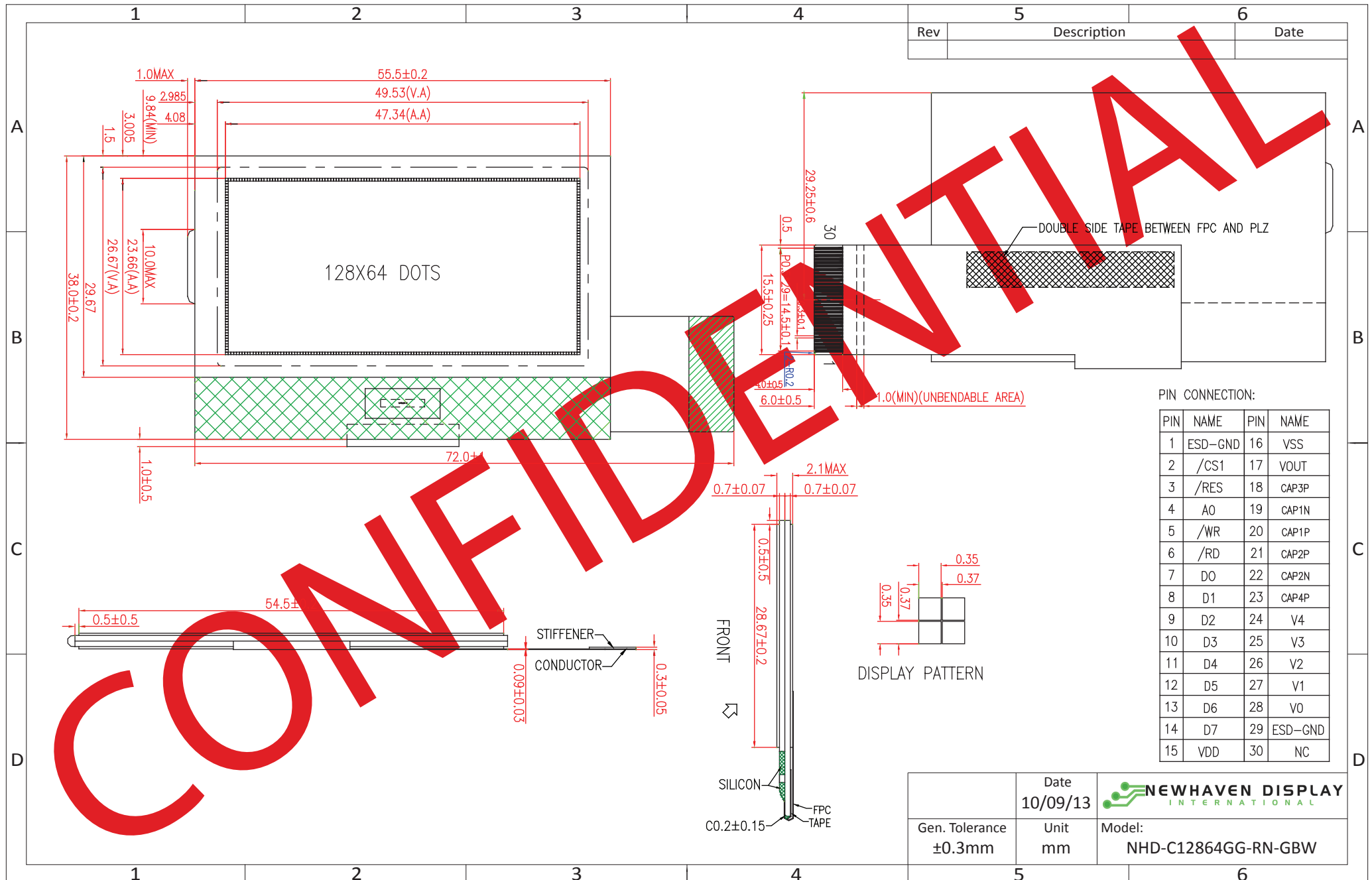

The drawing contained herein is the exclusive property of Newhaven Display International, Inc. and shall not be copied, reproduced, and/or disclosed in any format without permission.

## Pin Description and Wiring Diagram

Pin No.	Symbol	External Connection	Function Description
1	ESD-GND	Power Supply	Ground (can be a No Connect)
2	/CS1	MPU	Active LOW Chip Select signal
3	/RES	MPU	Active LOW Reset signal
4	A0	MPU	Register Select: '0' = Command, '1' = Data
5	/WR	MPU	Active LOW Write signal
6	/RD	MPU	Active LOW Read signal
7-14	D0-D7	MPU	8-bit bi-directional data bus
15	VDD	Power Supply	Supply Voltage for LCD and Logic (3.0V)
16	VSS	Power Supply	Ground
17	VOUT	Power Supply	1.0uF-2.2uF cap to VSS
18	C3+	Power Supply	1.0uF-2.2uF cap to C1- (Pin-19)
19	C1-	Power Supply	1.0uF-2.2uF cap to C3+ (Pin-18) and C1+ (Pin-20)
20	C1+	Power Supply	1.0uF-2.2uF cap to C1- (Pin-19)
21	C2+	Power Supply	1.0uF-2.2uF cap to C2- (Pin-22)
22	C2-	Power Supply	1.0uF-2.2uF cap to C2+(Pin-21) and C4+ (Pin-23)
23	C4+	Power Supply	1.0uF-2.2uF cap to C2- (Pin-22)
24	V4	Power Supply	0.1uF-1.0uF cap to VDD or VSS
25	V3	Power Supply	0.1uF-1.0uF cap to VDD or VSS
26	V2	Power Supply	0.1uF-1.0uF cap to VDD or VSS
27	V1	Power Supply	0.1uF-1.0uF cap to VDD or VSS
28	V0	Power Supply	0.1uF-1.0uF cap to VDD or VSS
29	ESD-GND	Power Supply	Ground (can be a No Connect)
30	NC	-	No Connect

**Recommended LCD connector:** 0.5mm pitch, 30 conductor FFC. Molex p/n: 52892-3095

**Backlight connector:** --- **Mates with:** ---

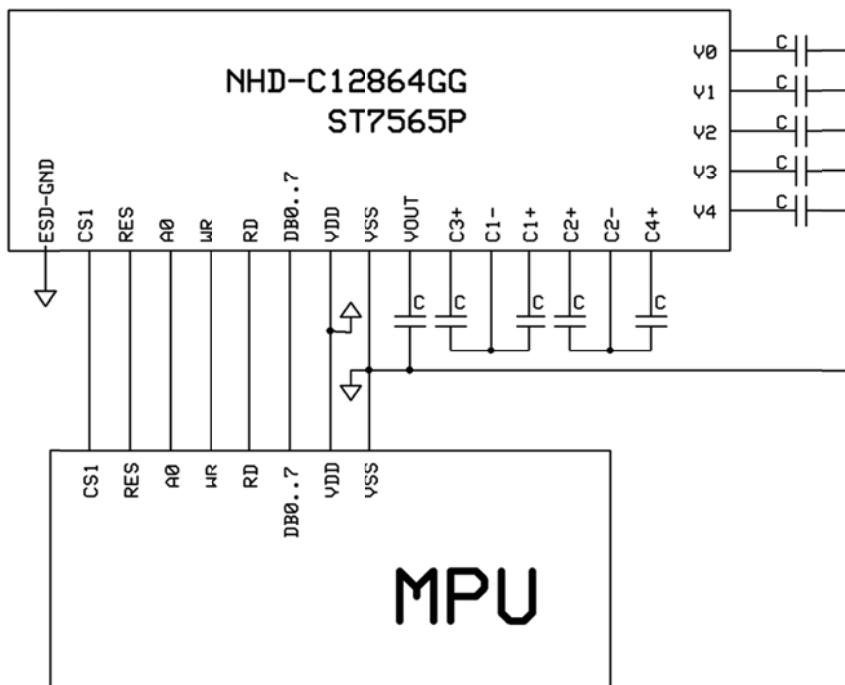

## Electrical Characteristics

Item	Symbol	Condition	Min.	Typ.	Max.	Unit
Operating Temperature Range	Top	Absolute Max	-20	-	+70	°C
Storage Temperature Range	Tst	Absolute Max	-30	-	+80	°C
Supply Voltage	VDD	-	3.0	3.0	3.3	V
Supply Current	IDD	Ta=25°C, VDD=3.0V	-	0.5	-	mA
Supply for LCD (contrast)	VDD-V0	Ta =25°C	-	9.0	-	V
"H" Level input	Vih	-	0.8*VDD	-	VDD	V
"L" Level input	Vil	-	VSS	-	0.2*VDD	V
"H" Level output	Voh	-	0.8*VDD	-	VDD	V
"L" Level output	Vol	-	VSS	-	0.2*VDD	V

## Optical Characteristics

Item	Symbol	Condition	Min.	Typ.	Max.	Unit
Viewing Angle – Top		CR ≥ 2	-	25	-	°
Viewing Angle – Bottom			-	45	-	°
Viewing Angle – Left			-	30	-	°
Viewing Angle – Right			-	30	-	°
Contrast Ratio	CR		3	4	-	-
Response Time (rise)	Tr		-	250	300	ms
Response Time (fall)	Tf		-	250	350	ms

## Controller Information

Built-in ST7565R controller.

Please download specification at [http://www.newhavendisplay.com/app\\_notes/ST7565R.pdf](http://www.newhavendisplay.com/app_notes/ST7565R.pdf)

## Table of Commands

Command	Command Code									Function			
	A0	/RD	/WR	D7	D6	D5	D4	D3	D2		D1	D0	
(1) Display ON/OFF	0	1	0	1	0	1	0	1	1	1	0	1	LCD display ON/OFF 0: OFF, 1: ON
(2) Display start line set	0	1	0	0	1	Display start address					0	Sets the display RAM display start line address	
(3) Page address set	0	1	0	1	0	1	Page address				0	Sets the display RAM page address	
(4) Column address set upper bit	0	1	0	0	0	0	1	Most significant column address			0	Sets the most significant 4 bits of the display RAM column address.	
Column address set lower bit				0	0	0	0	Least significant column address			0	Sets the least significant 4 bits of the display RAM column address.	
(5) Status read	0	0	1	Status			0	0	0	0	0	Reads the status data	
(6) Display data write	1	1	0	Write data						0	Writes to the display RAM		
(7) Display data read	1	0	1	Read data						0	Reads from the display RAM		
(8) ADC select	0	1	0	1	0	1	0	0	0	0	0	1	Sets the display RAM address SEG output correspondence 0: normal, 1: reverse
(9) Display normal/reverse	0	1	0	1	0	1	0	0	1	1	0	1	Sets the LCD display normal/ reverse 0: normal, 1: reverse
(10) Display all points ON/OFF	0	1	0	1	0	1	0	0	1	0	0	1	Display all points 0: normal display 1: all points ON
(11) LCD bias set	0	1	0	1	0	1	0	0	0	1	0	1	Sets the LCD drive voltage bias ratio 0: 1/9 bias, 1: 1/7 bias (ST7565R)
(12) Read-modify-write	0	1	0	1	1	1	0	0	0	0	0	0	Column address increment At write: +1 At read: 0
(13) End	0	1	0	1	1	1	0	1	1	1	0	0	Clear read/modify/write
(14) Reset	0	1	0	1	1	1	0	0	0	1	0	0	Internal reset
(15) Common output mode select	0	1	0	1	1	0	0	0	*	*	*	1	Select COM output scan direction 0: normal direction 1: reverse direction
(16) Power control set	0	1	0	0	0	1	0	1	Operating mode		0	0	Select internal power supply operating mode
(17) V <sub>0</sub> voltage regulator internal resistor ratio set	0	1	0	0	0	1	0	0	Resistor ratio		0	0	Select internal resistor ratio(Rb/Ra) mode
(18) Electronic volume mode set	0	1	0	1	0	0	0	0	0	0	0	1	Set the V <sub>0</sub> output voltage electronic volume register
Electronic volume register set				0	0	Electronic volume value					0		
(19) Sleep mode set	0	1	0	1	0	1	0	1	1	0	0	1	0: Sleep mode, 1: Normal mode
(20) Booster ratio set	0	1	0	1	1	1	1	1	0	0	0	0	select booster ratio 00: 2x,3x,4x 01: 5x 11: 6x
(21) NOP	0	1	0	1	1	1	0	0	0	0	1	1	Command for non-operation
(22) Test	0	1	0	1	1	1	1	*	*	*	*	*	Command for IC test. Do not use this command

# Timing Characteristics

## 8080 MPU Interface

Item	Signal	Symbol	condition	Min.	Max.	Unit
Address hold time	A0	tAH8		0	-	ns
Address setup time		tAW8		0	-	
Address cycle time		tCYC8		240	-	
Enable L pulse width(write)	WR	tCCLW		80	-	
Enable H pulse width(write)		tCCHW		80	-	
Enable L pulse width(read)	RD	tCCLR		140	-	
Enable H pulse width(read)		tCCHR		80	-	
Write data setup time	DB0~DB7	tDS8		40	-	
Write address hold time		tDH8		0	-	
Read access time		tACC8	CL=100Pf	-	70	
Read output disable time		tOH8	CL=100Pf	5	50	

Item	Signal	Symbol	Min.	Typ.	Max.	Unit
Reset time		tR	-	-	1.0	us
Reset 'L' pulse width	/RES	tRW	1.0	-	-	

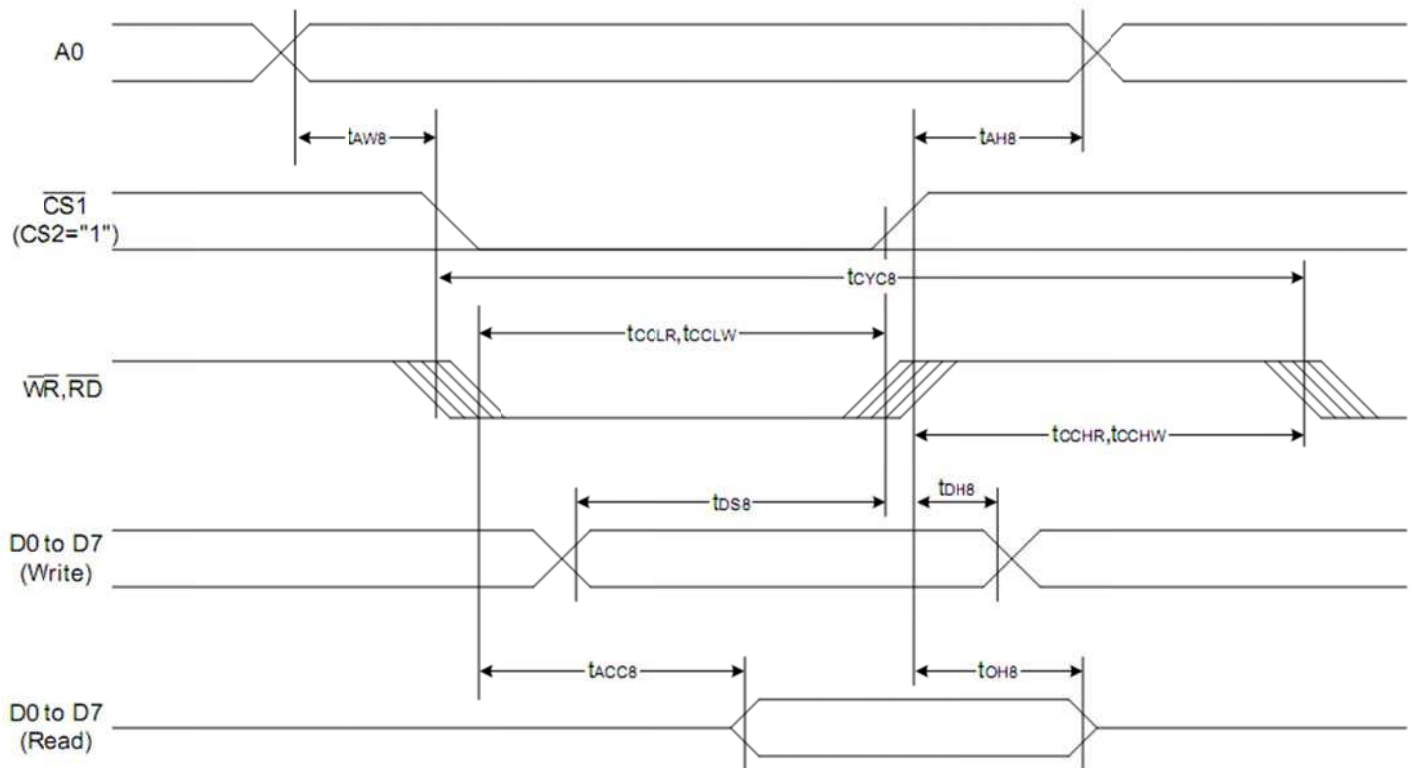

## Example Initialization Code

```
/**
 *
 */

void comm_out(unsigned char c)
{
    CS1 = 0;
    AO = 0;                //LOW = instruction
    WRT = 0;
    P1 = c;
    WRT = 1;
    CS1 = 1;
}

/**
 *
 */

void data_out(unsigned char d)
{
    CS1 = 0;
    AO = 1;                //HIGH = data
    WRT = 0;
    P1 = d;
    WRT = 1;
    CS1 = 1;
}

/**
 *
 */

void disp()
{
    unsigned int i, j;
    unsigned char page=0xB0;
    for(i=0;i<8;i++)        //fill display with checkerboard pattern
    {
        comm_out(0x10);    //set column address
        comm_out(0x00);    //set column address
        comm_out(page);    //set page address
        for(j=0;j<64;j++)
        {
            data_out(0xAA);
            data_out(0x55);
        }
        page++;
    }
}

/**
 *
 */
```



```

/*****/
/***** NHD-C12864GG DISPLAY INITIALIZATION *****/
/*****/

void init()
{
    RDD = 1;
    WRT = 1;
    CS1 = 0;
    RST = 0;
    delay(150);
    RST = 1;
    delay(150);

    comm_out(0xA2); //added 1/9 bias
    comm_out(0xA0); //ADC segment driver direction (A0=Normal)
    comm_out(0xC0); //COM output scan direction (C0=Normal)
    comm_out(0x25); //resistor ratio
    comm_out(0x81); //electronic volume mode set
    comm_out(0x15); //electronic volume register set
    comm_out(0x2F); //operating mode
    comm_out(0x40); //start line set
    comm_out(0xAF); //display ON

    delay(10);
}

/*****/

```

## Quality Information

Test Item	Content of Test	Test Condition	Note
High Temperature storage	Endurance test applying the high storage temperature for a long time.	+80°C , 96hrs	2
Low Temperature storage	Endurance test applying the low storage temperature for a long time.	-30°C , 96hrs	1,2
High Temperature Operation	Endurance test applying the electric stress (voltage & current) and the high thermal stress for a long time.	+70°C, 96hrs	2
Low Temperature Operation	Endurance test applying the electric stress (voltage & current) and the low thermal stress for a long time.	-20°C , 96hrs	1,2
High Temperature / Humidity Operation	Endurance test applying the electric stress (voltage & current) and the high thermal with high humidity stress for a long time.	+40°C , 90% RH , 96hrs	1,2
Thermal Shock resistance	Endurance test applying the electric stress (voltage & current) during a cycle of low and high thermal stress.	-0°C,30min -> 25°C,5min -> 50°C,30min = 1 cycle 10 cycles	
Vibration test	Endurance test applying vibration to simulate transportation and use.	10-55Hz , 15mm amplitude. 60 sec in each of 3 directions X,Y,Z For 15 minutes	3
Static electricity test	Endurance test applying electric static discharge.	VS=800V, RS=1.5kΩ, CS=100pF One time	

**Note 1:** No condensation to be observed.

**Note 2:** Conducted after 4 hours of storage at 25°C, 0%RH.

**Note 3:** Test performed on product itself, not inside a container.

## Precautions for using LCDs/LCMs

See Precautions at [www.newhavendisplay.com/specs/precautions.pdf](http://www.newhavendisplay.com/specs/precautions.pdf)

## Warranty Information

See Terms & Conditions at [http://www.newhavendisplay.com/index.php?main\\_page=terms](http://www.newhavendisplay.com/index.php?main_page=terms)