

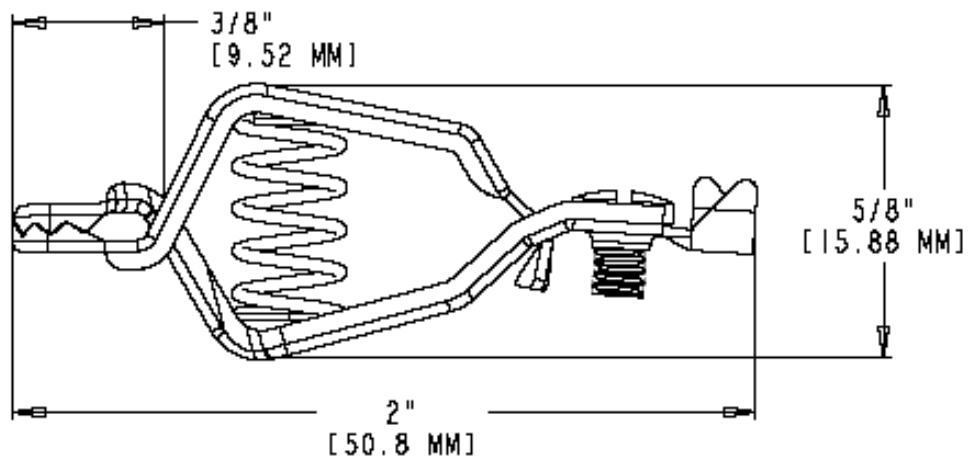

Part Number: BU-48B/BU-48C
Description: Automotive Analyzer Clip

3707

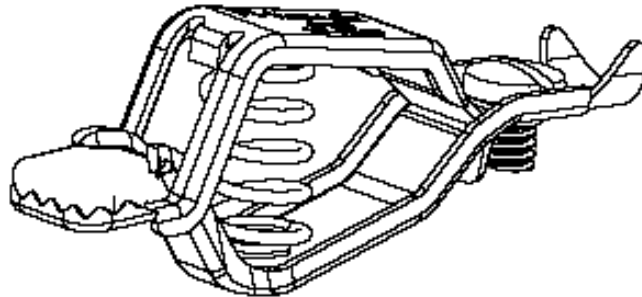

- Automotive Analyzer Clip
- Teeth mesh on three sides of the jaw
- Primary use is for automotive analyzers and test systems
- Crimp or screw connection
- Jaw open 0.5" (12.7 mm) max
- Material: Zinc-plated steel-10 Amp (BU-48B) or solid copper-20 Amps (BU-48C)
- Length: 2" (50.8 mm)
- Federal Spec: CID AA59466-007 (BU-48C)
- RoHS Compliant