

## SUPER-LOW OUTPUT VOLTAGE LOW DROPOUT CMOS VOLTAGE REGULATOR

The S-11L10 Series, developed by using the CMOS technology, is a positive voltage regulator IC which has low output voltage, high-accuracy output voltage and low current consumption (150 mA output current).

A 1.0  $\mu$ F small ceramic capacitor can be used. It operates with low current consumption of 9  $\mu$ A typ.

The overcurrent protection circuit prevents the load current from exceeding the current capacitance of output transistor. The ON / OFF circuit ensures longer battery life.

Various capacitors, also small ceramic capacitors, can be used for this IC more than for the conventional regulator ICs which have CMOS technology.

Furthermore, small SOT-23-5 and SNT-6A(H) packages realize high-density mounting.

### ■ Features

- Output voltage: 0.8 V to 3.3 V, selectable in 0.05 V step
- Input voltage: 1.2 V to 3.65 V
- Output voltage accuracy:  $\pm 1.0\%$  (0.8 V to 1.45 V output product :  $\pm 15$  mV)
- Dropout voltage: 210 mV typ. (1.5 V output product,  $I_{OUT} = 100$  mA)
- Current consumption:
  - During operation: 9  $\mu$ A typ., 16  $\mu$ A max.
  - During power-off: 0.1  $\mu$ A typ., 0.9  $\mu$ A max.
- Output current: Possible to output 150 mA ( $V_{IN} \geq V_{OUT(S)} + 1.0$  V)<sup>\*1</sup>
- Input and output capacitors: A ceramic capacitor of 1.0  $\mu$ F or more can be used.
- Ripple rejection: 60 dB typ. (1.25 V output product,  $f = 1.0$  kHz)
- Built-in overcurrent protection circuit: Limits overcurrent of output transistor.
- Built-in ON / OFF circuit: Ensures long battery life.
- Built-in Discharge shunt function
- Constant current source pull-down is selectable
- Operation temperature range:  $T_a = -40^\circ\text{C}$  to  $+85^\circ\text{C}$
- Lead-free, Sn 100%, halogen-free<sup>\*2</sup>

\*1. Attention should be paid to the power dissipation of the package when the output current is large.

\*2. Refer to “**■ Product Name Structure**” for details.

### ■ Applications

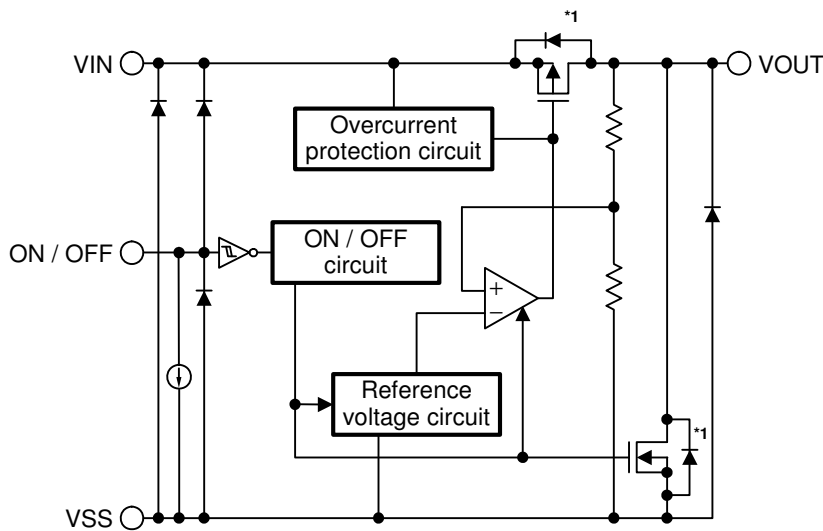
- Power supply for battery-powered device
- Power supply for mobile phone
- Power supply for portable equipment

### ■ Packages

- SOT-23-5
- SNT-6A(H)

■ **Block Diagrams**

1. **S-11L10 Series B type**

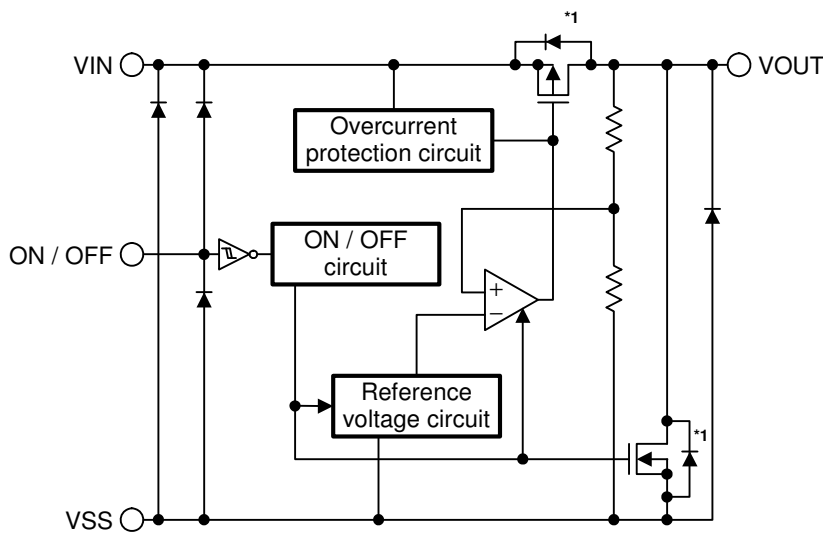


Function	Status
ON / OFF logic	Active "H"
Constant current source pull-down	Available

\*1. Parasitic diode

Figure 1

2. **S-11L10 Series D type**



Function	Status
ON / OFF logic	Active "H"
Constant current source pull-down	Unavailable

\*1. Parasitic diode

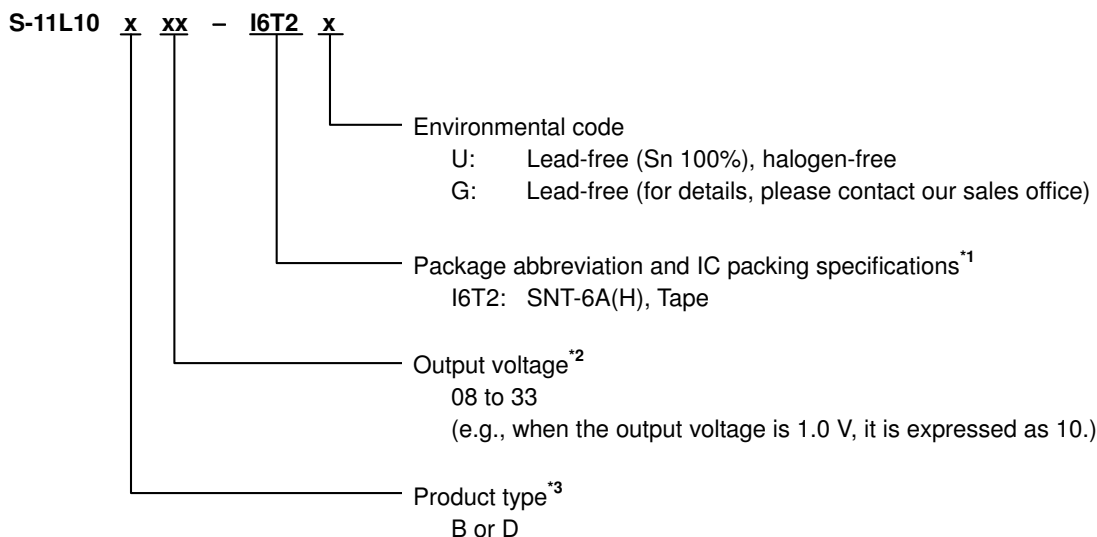
Figure 2

■ **Product Name Structure**

Users can select the product type, output voltage, and package type for the S-11L10 Series. Refer to “**1. Product name**” regarding the contents of product name, “**2. Function list of product type**” regarding the product type, “**3. Package**” regarding the package drawings, “**4. Product name list**” regarding details of the product name.

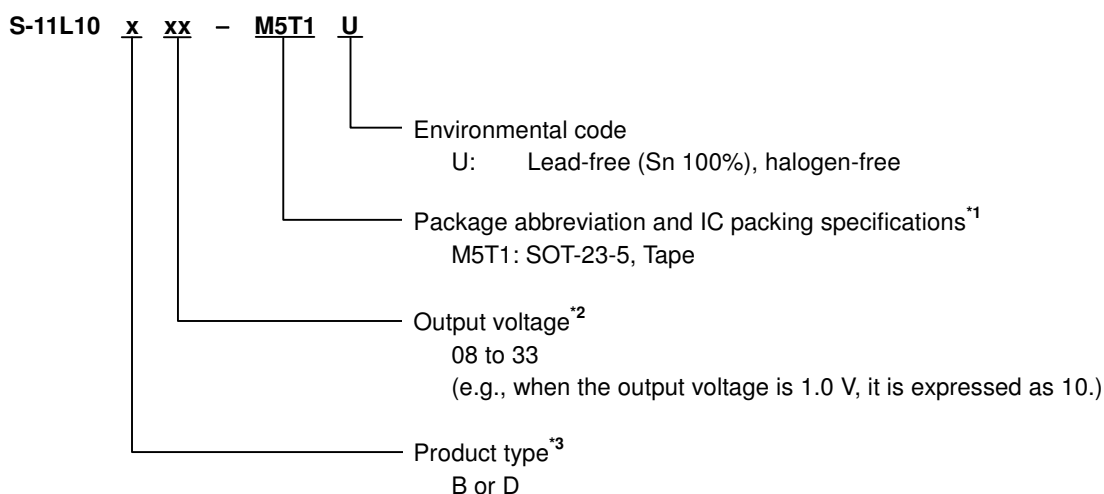
**1. Product name**

**1.1 SNT-6A(H)**



- \*1. Refer to the tape drawing.
- \*2. If you request the product which has 0.05 V step, contact our sales office.
- \*3. Refer to “**2. Function list of product type**”.

**1.2 SOT-23-5**



- \*1. Refer to the tape drawing.
- \*2. If you request the product which has 0.05 V step, contact our sales office.
- \*3. Refer to “**2. Function list of product type**”.

**2. Function list of product type**

**Table 1**

Product Type	ON / OFF Logic	Constant Current Source Pull-down
B	Active "H"	Available
D	Active "H"	Unavailable

**3. Package**

Package Name	Drawing Code			
	Package	Tape	Reel	Land
SOT-23-5	MP005-A-P-SD	MP005-A-C-SD	MP005-A-R-SD	—
SNT-6A(H)	PI006-A-P-SD	PI006-A-C-SD	PI006-A-R-SD	PI006-A-L-SD

**4. Product name list**

**4.1 S-11L10 Series B type**

ON / OFF logic:                      Active "H"                      Constant current source pull-down:                      Available

**Table 2**

Output voltage	SOT-23-5	SNT-6A(H)
0.8 V±15 mV	S-11L10B08-M5T1U	S-11L10B08-I6T2x
0.9 V±15 mV	S-11L10B09-M5T1U	S-11L10B09-I6T2x
1.0 V±15 mV	S-11L10B10-M5T1U	S-11L10B10-I6T2x
1.1 V±15 mV	S-11L10B11-M5T1U	S-11L10B11-I6T2x
1.2 V±15 mV	S-11L10B12-M5T1U	S-11L10B12-I6T2x
1.3 V±15 mV	S-11L10B13-M5T1U	S-11L10B13-I6T2x
1.4 V±15 mV	S-11L10B14-M5T1U	S-11L10B14-I6T2x
1.5 V±1.0%	S-11L10B15-M5T1U	S-11L10B15-I6T2x
1.6 V±1.0%	S-11L10B16-M5T1U	S-11L10B16-I6T2x
1.7 V±1.0%	S-11L10B17-M5T1U	S-11L10B17-I6T2x
1.8 V±1.0%	S-11L10B18-M5T1U	S-11L10B18-I6T2x
1.9 V±1.0%	S-11L10B19-M5T1U	S-11L10B19-I6T2x
2.0 V±1.0%	S-11L10B20-M5T1U	S-11L10B20-I6T2x
2.1 V±1.0%	S-11L10B21-M5T1U	S-11L10B21-I6T2x
2.2 V±1.0%	S-11L10B22-M5T1U	S-11L10B22-I6T2x
2.3 V±1.0%	S-11L10B23-M5T1U	S-11L10B23-I6T2x
2.4 V±1.0%	S-11L10B24-M5T1U	S-11L10B24-I6T2x
2.5 V±1.0%	S-11L10B25-M5T1U	S-11L10B25-I6T2x
2.6 V±1.0%	S-11L10B26-M5T1U	S-11L10B26-I6T2x
2.7 V±1.0%	S-11L10B27-M5T1U	S-11L10B27-I6T2x
2.8 V±1.0%	S-11L10B28-M5T1U	S-11L10B28-I6T2x
2.9 V±1.0%	S-11L10B29-M5T1U	S-11L10B29-I6T2x
3.0 V±1.0%	S-11L10B30-M5T1U	S-11L10B30-I6T2x
3.1 V±1.0%	S-11L10B31-M5T1U	S-11L10B31-I6T2x
3.2 V±1.0%	S-11L10B32-M5T1U	S-11L10B32-I6T2x
3.3 V±1.0%	S-11L10B33-M5T1U	S-11L10B33-I6T2x

- Remark**
- Please contact our sales office for products with specifications other than the above.
  - x: G or U
  - Please select products of environmental code = U for Sn 100%, halogen-free products.

# SUPER-LOW OUTPUT VOLTAGE LOW DROPOUT CMOS VOLTAGE REGULATOR

Rev.2.1\_00

S-11L10 Series

## 4.2 S-11L10 Series D type

ON / OFF logic:                      Active "H"                      Constant current source pull-down:                      Unavailable

**Table 3**

Output voltage	SOT-23-5	SNT-6A(H)
0.8 V±15 mV	S-11L10D08-M5T1U	S-11L10D08-I6T2x
0.9 V±15 mV	S-11L10D09-M5T1U	S-11L10D09-I6T2x
1.0 V±15 mV	S-11L10D10-M5T1U	S-11L10D10-I6T2x
1.1 V±15 mV	S-11L10D11-M5T1U	S-11L10D11-I6T2x
1.2 V±15 mV	S-11L10D12-M5T1U	S-11L10D12-I6T2x
1.3 V±15 mV	S-11L10D13-M5T1U	S-11L10D13-I6T2x
1.4 V±15 mV	S-11L10D14-M5T1U	S-11L10D14-I6T2x
1.5 V±1.0%	S-11L10D15-M5T1U	S-11L10D15-I6T2x
1.6 V±1.0%	S-11L10D16-M5T1U	S-11L10D16-I6T2x
1.7 V±1.0%	S-11L10D17-M5T1U	S-11L10D17-I6T2x
1.8 V±1.0%	S-11L10D18-M5T1U	S-11L10D18-I6T2x
1.9 V±1.0%	S-11L10D19-M5T1U	S-11L10D19-I6T2x
2.0 V±1.0%	S-11L10D20-M5T1U	S-11L10D20-I6T2x
2.1 V±1.0%	S-11L10D21-M5T1U	S-11L10D21-I6T2x
2.2 V±1.0%	S-11L10D22-M5T1U	S-11L10D22-I6T2x
2.3 V±1.0%	S-11L10D23-M5T1U	S-11L10D23-I6T2x
2.4 V±1.0%	S-11L10D24-M5T1U	S-11L10D24-I6T2x
2.5 V±1.0%	S-11L10D25-M5T1U	S-11L10D25-I6T2x
2.6 V±1.0%	S-11L10D26-M5T1U	S-11L10D26-I6T2x
2.7 V±1.0%	S-11L10D27-M5T1U	S-11L10D27-I6T2x
2.8 V±1.0%	S-11L10D28-M5T1U	S-11L10D28-I6T2x
2.9 V±1.0%	S-11L10D29-M5T1U	S-11L10D29-I6T2x
3.0 V±1.0%	S-11L10D30-M5T1U	S-11L10D30-I6T2x
3.1 V±1.0%	S-11L10D31-M5T1U	S-11L10D31-I6T2x
3.2 V±1.0%	S-11L10D32-M5T1U	S-11L10D32-I6T2x
3.3 V±1.0%	S-11L10D33-M5T1U	S-11L10D33-I6T2x

- Remark**
1. Please contact our sales office for products with specifications other than the above.
  2. x: G or U
  3. Please select products of environmental code = U for Sn 100%, halogen-free products.

■ Pin Configuration

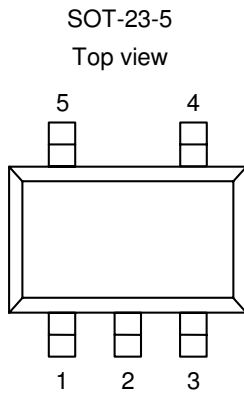


Figure 3

**Table 4**

Pin No.	Symbol	Description
1	VIN	Input voltage pin
2	VSS	GND pin
3	ON / OFF	ON / OFF pin
4	NC <sup>*1</sup>	No connection
5	VOUT	Output voltage pin

\*1. The NC pin is electrically open.  
 The NC pin can be connected to VIN pin or VSS pin.

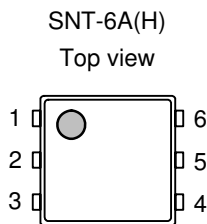


Figure 4

**Table 5**

Pin No.	Symbol	Description
1	VOUT	Output voltage pin
2	VSS	GND pin
3	NC <sup>*1</sup>	No connection
4	ON / OFF	ON / OFF pin
5	VSS	GND pin
6	VIN	Input voltage pin

\*1. The NC pin is electrically open.  
 The NC pin can be connected to VIN pin or VSS pin.

■ **Absolute Maximum Ratings**

**Table 6**

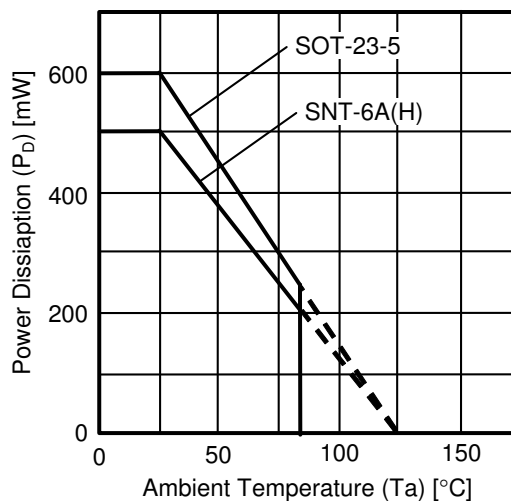
(Ta = +25°C unless otherwise specified)

Item	Symbol	Absolute Maximum Rating	Unit	
Input voltage	$V_{IN}$	$V_{SS} - 0.3$ to $V_{SS} + 4.0$	V	
	$V_{ON/OFF}$	$V_{SS} - 0.3$ to $V_{IN} + 0.3$	V	
Output voltage	$V_{OUT}$	$V_{SS} - 0.3$ to $V_{IN} + 0.3$	V	
Power dissipation	SOT-23-5 SNT-6A(H)	$P_D$	$600^{*1}$	mW
			$500^{*1}$	mW
Operation ambient temperature	$T_{opr}$	-40 to +85	°C	
Storage temperature	$T_{stg}$	-40 to +125	°C	

\*1. When mounted on board  
[Mounted board]

- (1) Board size: 114.3 mm × 76.2 mm × t1.6 mm
- (2) Name: JEDEC STANDARD51-7

**Caution** The absolute maximum ratings are rated values exceeding which the product could suffer physical damage. These values must therefore not be exceeded under any conditions.



**Figure 5 Power Dissipation of Package (When Mounted on Board)**

■ **Electrical Characteristics**

**Table 7 (1 / 2)**

(Ta = +25°C unless otherwise specified)

Item	Symbol	Conditions	Min.	Typ.	Max.	Unit	Test Circuit	
Output voltage*1	V <sub>OUT(E)</sub>	V <sub>IN</sub> = V <sub>OUT(S)</sub> + 1.0 V, I <sub>OUT</sub> = 30 mA	0.8 V ≤ V <sub>OUT(S)</sub> < 1.5 V	V <sub>OUT(S)</sub> − 0.015	V <sub>OUT(S)</sub>	V <sub>OUT(S)</sub> + 0.015	V	1
			1.5 V ≤ V <sub>OUT(S)</sub> ≤ 2.65 V	V <sub>OUT(S)</sub> × 0.99	V <sub>OUT(S)</sub>	V <sub>OUT(S)</sub> × 1.01	V	1
		V <sub>IN</sub> = 3.65 V, I <sub>OUT</sub> = 30 mA	2.65 V < V <sub>OUT(S)</sub> ≤ 3.3 V	V <sub>OUT(S)</sub> × 0.99	V <sub>OUT(S)</sub>	V <sub>OUT(S)</sub> × 1.01	V	1
Output current*2	I <sub>OUT</sub>	V <sub>IN</sub> ≥ V <sub>OUT(S)</sub> + 1.0 V	0.8 V ≤ V <sub>OUT(S)</sub> ≤ 2.65 V	150*5	—	—	mA	3
		V <sub>IN</sub> = 3.65 V	2.65 V < V <sub>OUT(S)</sub> ≤ 3.3 V	150*5	—	—	mA	3
Dropout voltage*3	V <sub>drop</sub>	I <sub>OUT</sub> = 100 mA	0.8 V ≤ V <sub>OUT(S)</sub> < 1.1 V	0.40	0.44	0.48	V	1
			1.1 V ≤ V <sub>OUT(S)</sub> < 1.3 V	—	0.28	0.42	V	1
			1.3 V ≤ V <sub>OUT(S)</sub> < 1.5 V	—	0.24	0.36	V	1
			1.5 V ≤ V <sub>OUT(S)</sub> < 1.7 V	—	0.21	0.32	V	1
			1.7 V ≤ V <sub>OUT(S)</sub> ≤ 3.3 V	—	0.19	0.29	V	1
Line regulation	$\frac{\Delta V_{OUT1}}{\Delta V_{IN} \cdot V_{OUT}}$	V <sub>OUT(S)</sub> + 0.5 V ≤ V <sub>IN</sub> ≤ 3.65 V, I <sub>OUT</sub> = 30 mA	0.8 V ≤ V <sub>OUT(S)</sub> < 2.9 V	—	0.05	0.2	%/V	1
		3.4 V ≤ V <sub>IN</sub> ≤ 3.65 V, I <sub>OUT</sub> = 30 mA	2.9 V ≤ V <sub>OUT(S)</sub> ≤ 3.3 V	—	0.05	0.2	%/V	1
Load regulation	ΔV <sub>OUT2</sub>	V <sub>IN</sub> = V <sub>OUT(S)</sub> + 1.0 V, 10 μA ≤ I <sub>OUT</sub> ≤ 100 mA	0.8 V ≤ V <sub>OUT(S)</sub> ≤ 2.65 V	—	20	40	mV	1
		V <sub>IN</sub> = 3.65 V, 10 μA ≤ I <sub>OUT</sub> ≤ 100 mA	2.65 V < V <sub>OUT(S)</sub> ≤ 3.3 V	—	20	40	mV	1
Output voltage temperature coefficient*4	$\frac{\Delta V_{OUT}}{\Delta T_a \cdot V_{OUT}}$	V <sub>IN</sub> = V <sub>OUT(S)</sub> + 1.0 V, I <sub>OUT</sub> = 30 mA, −40°C ≤ Ta ≤ +85°C	0.8 V ≤ V <sub>OUT(S)</sub> ≤ 2.65 V	—	±150	—	ppm/°C	1
		V <sub>IN</sub> = 3.65 V, I <sub>OUT</sub> = 30 mA, −40°C ≤ Ta ≤ +85°C	2.65 V < V <sub>OUT(S)</sub> ≤ 3.3 V	—	±150	—	ppm/°C	1
Current consumption during operation	I <sub>SS1</sub>	V <sub>IN</sub> = V <sub>OUT(S)</sub> + 1.0 V, ON / OFF pin = ON, no load	0.8 V ≤ V <sub>OUT(S)</sub> ≤ 2.65 V	—	9	16	μA	2
		V <sub>IN</sub> = 3.65 V, ON / OFF pin = ON, no load	2.65 V < V <sub>OUT(S)</sub> ≤ 3.3 V	—	9	16	μA	2
Current consumption during power-off	I <sub>SS2</sub>	V <sub>IN</sub> = V <sub>OUT(S)</sub> + 1.0 V, ON / OFF pin = OFF, no load	0.8 V ≤ V <sub>OUT(S)</sub> ≤ 2.65 V	—	0.1	0.9	μA	2
		V <sub>IN</sub> = 3.65 V, ON / OFF pin = OFF, no load	2.65 V < V <sub>OUT(S)</sub> ≤ 3.3 V	—	0.1	0.9	μA	2



# SUPER-LOW OUTPUT VOLTAGE LOW DROPOUT CMOS VOLTAGE REGULATOR

Rev.2.1\_00

S-11L10 Series

**Table 7 (2 / 2)**

(Ta = +25°C unless otherwise specified)

Item	Symbol	Conditions	Min.	Typ.	Max.	Unit	Test Circuit	
Input voltage	V <sub>IN</sub>	—	1.2	—	3.65	V	—	
ON / OFF pin input voltage "H"	V <sub>SH</sub>	V <sub>IN</sub> = V <sub>OUT(S)</sub> + 1.0 V, R <sub>L</sub> = 1.0 kΩ, determined by V <sub>OUT</sub> output level	0.8 V ≤ V <sub>OUT(S)</sub> ≤ 2.65 V	0.9	—	—	V	4
		V <sub>IN</sub> = 3.65 V, R <sub>L</sub> = 1.0 kΩ, determined by V <sub>OUT</sub> output level	2.65 V < V <sub>OUT(S)</sub> ≤ 3.3 V	0.9	—	—	V	4
ON / OFF pin input voltage "L"	V <sub>SL</sub>	V <sub>IN</sub> = V <sub>OUT(S)</sub> + 1.0 V, R <sub>L</sub> = 1.0 kΩ, determined by V <sub>OUT</sub> output level	0.8 V ≤ V <sub>OUT(S)</sub> ≤ 2.65 V	—	—	0.2	V	4
		V <sub>IN</sub> = 3.65 V, R <sub>L</sub> = 1.0 kΩ, determined by V <sub>OUT</sub> output level	2.65 V < V <sub>OUT(S)</sub> ≤ 3.3 V	—	—	0.2	V	4
ON / OFF pin input current "H"	I <sub>SH</sub>	V <sub>IN</sub> = 3.65 V, V <sub>ON / OFF</sub> = 3.65 V	B type	0.05	—	0.55	μA	4
			D type	-0.1	—	0.1	μA	4
ON / OFF pin input current "L"	I <sub>SL</sub>	V <sub>IN</sub> = 3.65 V, V <sub>ON / OFF</sub> = 0 V	-0.1	—	0.1	μA	4	
Ripple rejection	RR	V <sub>IN</sub> = V <sub>OUT(S)</sub> + 1.0 V, f = 1.0 kHz, ΔV <sub>rip</sub> = 0.5 Vrms, I <sub>OUT</sub> = 30 mA	0.8 V ≤ V <sub>OUT(S)</sub> ≤ 1.25 V	—	60	—	dB	5
			1.25 V < V <sub>OUT(S)</sub> ≤ 2.65 V	—	55	—	dB	5
		V <sub>IN</sub> = 3.65 V, f = 1.0 kHz, ΔV <sub>rip</sub> = 0.5 Vrms, I <sub>OUT</sub> = 30 mA	2.65 V < V <sub>OUT(S)</sub> ≤ 3.3 V	—	55	—	dB	5
Short-circuit current	I <sub>short</sub>	V <sub>IN</sub> = V <sub>OUT(S)</sub> + 1.0 V, ON / OFF pin = ON, V <sub>OUT</sub> = 0 V	0.8 V ≤ V <sub>OUT(S)</sub> ≤ 2.65 V	—	150	—	mA	3
		V <sub>IN</sub> = 3.65 V, ON / OFF pin = ON, V <sub>OUT</sub> = 0 V	2.65 V < V <sub>OUT(S)</sub> ≤ 3.3 V	—	150	—	mA	3
"L" output Nch ON resistance	R <sub>LOW</sub>	V <sub>OUT</sub> = 0.1 V, V <sub>IN</sub> = 3.65 V	—	100	—	Ω	3	

\*1. V<sub>OUT(S)</sub>: Set output voltage

V<sub>OUT(E)</sub>: Actual output voltage

Output voltage when fixing I<sub>OUT</sub>(= 30 mA) and inputting V<sub>OUT(S)</sub> + 1.0 V or 3.65 V

\*2. The output current at which the output voltage becomes 95% of V<sub>OUT(E)</sub> after gradually increasing the output current.

\*3. V<sub>drop</sub> = V<sub>IN1</sub> - (V<sub>OUT3</sub> × 0.98)

V<sub>OUT3</sub> is the output voltage when V<sub>IN</sub> = V<sub>OUT(S)</sub> + 1.0 V or 3.65 V and I<sub>OUT</sub> = 100 mA.

V<sub>IN1</sub> is the input voltage at which the output voltage becomes 98% of V<sub>OUT3</sub> after gradually decreasing the input voltage.

\*4. A change in temperature of the output voltage [mV/°C] is calculated using the following equation.

$$\frac{\Delta V_{OUT}}{\Delta T_a} [\text{mV}/^\circ\text{C}]^{*1} = V_{OUT(S)} [\text{V}]^{*2} \times \frac{\Delta V_{OUT}}{\Delta T_a \bullet V_{OUT}} [\text{ppm}/^\circ\text{C}]^{*3} \div 1000$$

\*1. Change in temperature of output voltage

\*2. Set output voltage

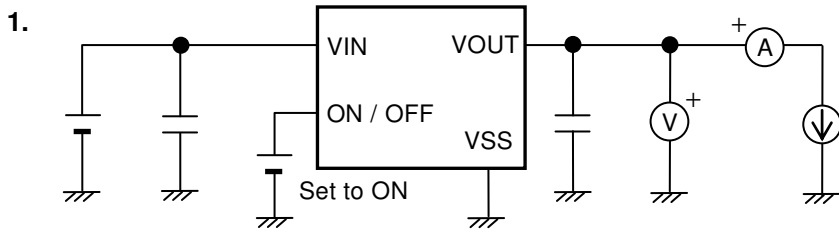
\*3. Output voltage temperature coefficient

\*5. The output current can be at least this value.

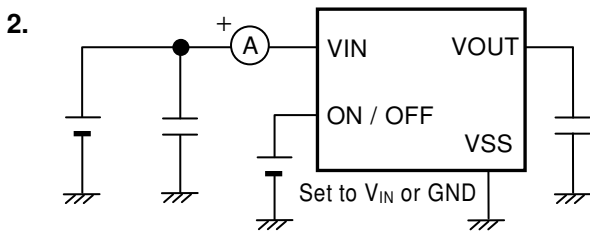
Due to restrictions on the package power dissipation, this value may not be satisfied. Attention should be paid to the power dissipation of the package when the output current is large.

This specification is guaranteed by design.

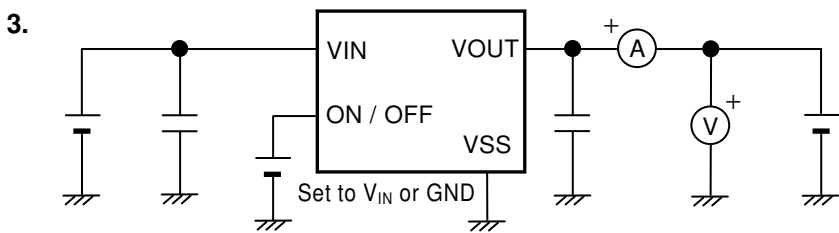
■ **Test Circuits**



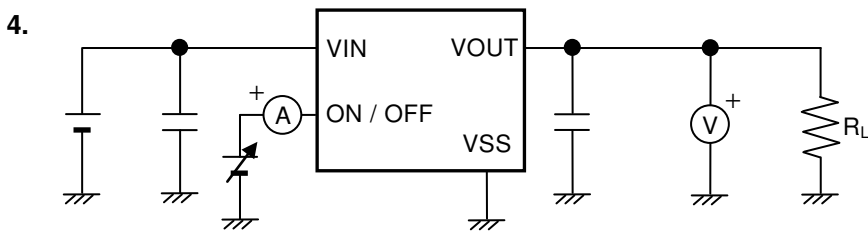
**Figure 6**



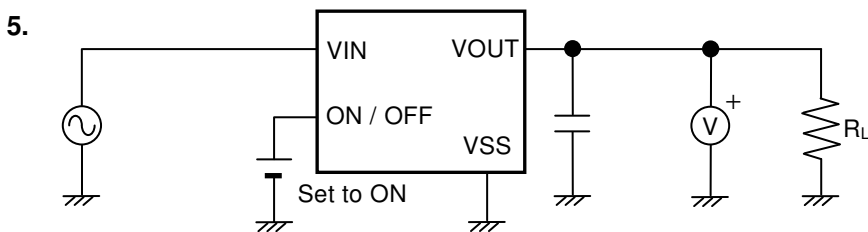
**Figure 7**



**Figure 8**

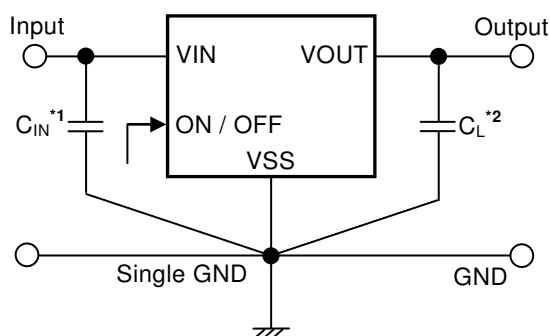


**Figure 9**



**Figure 10**

■ **Standard Circuit**



- \*1.  $C_{IN}$  is a capacitor for stabilizing the input.
- \*2. A ceramic capacitor of 1.0  $\mu\text{F}$  or more can be used as  $C_L$ .

**Figure 11**

**Caution** The above connection diagram and constant will not guarantee successful operation. Perform thorough evaluation using the actual application to set the constant.

■ **Condition of Application**

- Input capacitor ( $C_{IN}$ ): 1.0  $\mu\text{F}$  or more
- Output capacitor ( $C_L$ ): 1.0  $\mu\text{F}$  or more

**Caution** Generally a series regulator may cause oscillation, depending on the selection of external parts. Confirm that no oscillation occurs in the application for which the above capacitors are used.

■ **Selection of Input and Output Capacitors ( $C_{IN}$ ,  $C_L$ )**

The S-11L10 Series requires an output capacitor between the VOUT pin and VSS pin for phase compensation. Operation is stabilized by a ceramic capacitor with an output capacitance of 1.0  $\mu\text{F}$  or more over the entire temperature range. When using an OS capacitor, a tantalum capacitor, or an aluminum electrolytic capacitor, the capacitance must be 1.0  $\mu\text{F}$  or more.

The value of the output overshoot or undershoot transient response varies depending on the value of the output capacitor. The required capacitance of the input capacitor differs depending on the application.

The recommended capacitance for an application is  $C_{IN} \geq 1.0 \mu\text{F}$ ,  $C_L \geq 1.0 \mu\text{F}$ ; however, when selecting the output capacitor, perform sufficient evaluation, including evaluation of temperature characteristics, on the actual device.

## ■ Explanation of Terms

### 1. Low dropout voltage regulator

This voltage regulator has the low dropout voltage due to its built-in low on-resistance transistor.

### 2. Output voltage ( $V_{OUT}$ )

The accuracy of the output voltage is ensured at  $\pm 1.0\%$  or  $\pm 15 \text{ mV}^{\ast 1}$  under the specified conditions of fixed input voltage<sup>\*2</sup>, fixed output current, and fixed temperature.

\*1. When  $V_{OUT} < 1.5 \text{ V}$ :  $\pm 15 \text{ mV}$ , when  $1.5 \text{ V} \leq V_{OUT}$ :  $\pm 1.0\%$

\*2. Differs depending on the product.

**Caution** If the above conditions change, the output voltage value may vary and exceed the accuracy range of the output voltage. Refer to “■ Electrical Characteristics” and “■ Characteristics (Typical Data)” for details.

### 3. Line regulation $\left( \frac{\Delta V_{OUT1}}{\Delta V_{IN} \bullet V_{OUT}} \right)$

Indicates the dependency of the output voltage on the input voltage. That is, the values show how much the output voltage changes due to a change in the input voltage with the output current remaining unchanged.

### 4. Load regulation ( $\Delta V_{OUT2}$ )

Indicates the dependency of the output voltage on the output current. That is, the values show how much the output voltage changes due to a change in the output current with the input voltage remaining unchanged.

### 5. Dropout voltage ( $V_{drop}$ )

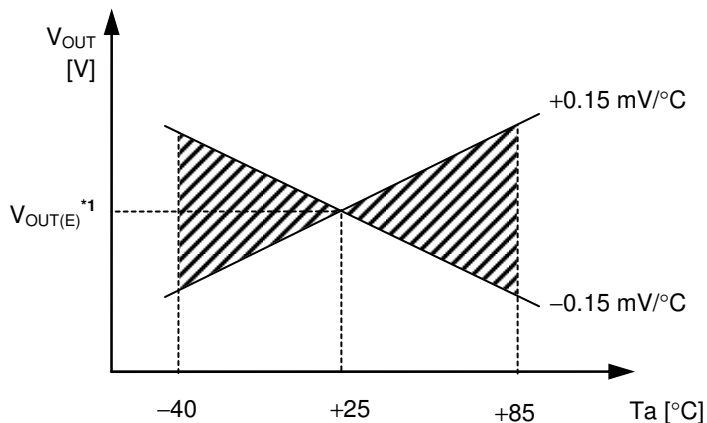
Indicates the difference between input voltage ( $V_{IN1}$ ) and the output voltage when; decreasing input voltage ( $V_{IN}$ ) gradually until the output voltage has dropped out to the value of 98% of output voltage ( $V_{OUT3}$ ), which is at  $V_{IN} = V_{OUT(S)} + 1.0 \text{ V}$ .

$$V_{drop} = V_{IN1} - (V_{OUT3} \times 0.98)$$

**6. Output voltage temperature coefficient**  $\left(\frac{\Delta V_{OUT}}{\Delta T_a \bullet V_{OUT}}\right)$

The shaded area in **Figure 12** is the range where  $V_{OUT}$  varies in the operation temperature range when the output voltage temperature coefficient is  $\pm 150$  ppm/ $^{\circ}\text{C}$ .

Example of S-11L10B10 typ. product



\*1.  $V_{OUT(E)}$  is the value of the output voltage measured at  $T_a = +25^{\circ}\text{C}$ .

**Figure 12**

A change in the temperature of the output voltage [mV/ $^{\circ}\text{C}$ ] is calculated using the following equation.

$$\frac{\Delta V_{OUT}}{\Delta T_a} [\text{mV}/^{\circ}\text{C}]^{*1} = V_{OUT(S)} [\text{V}]^{*2} \times \frac{\Delta V_{OUT}}{\Delta T_a \bullet V_{OUT}} [\text{ppm}/^{\circ}\text{C}]^{*3} \div 1000$$

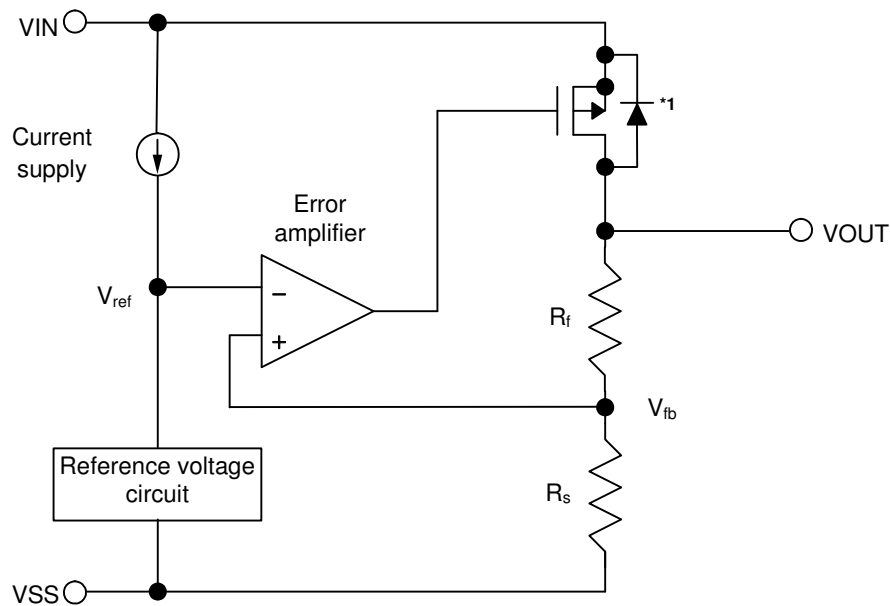
- \*1. Change in temperature of output voltage
- \*2. Set output voltage
- \*3. Output voltage temperature coefficient

■ **Operation**

**1. Basic operation**

**Figure 13** shows the block diagram of the S-11L10 Series.

The error amplifier compares the reference voltage ( $V_{ref}$ ) with feedback voltage ( $V_{fb}$ ), which is the output voltage resistance-divided by feedback resistors ( $R_s$  and  $R_f$ ). It supplies the gate voltage necessary to maintain the constant output voltage which is not influenced by the input voltage and temperature change, to the output transistor.



\*1. Parasitic diode

**Figure 13**

**2. Output transistor**

In the S-11L10 Series, a low on-resistance P-channel MOS FET is used as the output transistor.

Be sure that  $V_{OUT}$  does not exceed  $V_{IN} + 0.3$  V to prevent the voltage regulator from being damaged due to reverse current flowing from the VOUT pin through a parasitic diode to the VIN pin, when the potential of  $V_{OUT}$  became higher than  $V_{IN}$ .

### 3. ON / OFF pin

This pin starts and stops the regulator.

When the ON / OFF pin is set to OFF level, the entire internal circuit stops operating, and the built-in P-channel MOS FET output transistor between the VIN pin and the VOUT pin is turned off, reducing current consumption significantly.

Since the S-11L10 Series has a built-in discharge shunt circuit to discharge the output capacitance, the VOUT pin is forcibly set to the V<sub>SS</sub> level. The ON / OFF pin is configured as shown in **Figure 14** and **Figure 15**.

#### 3.1 S-11L10 Series B type

The ON / OFF pin is internally pulled down to the VSS pin in the floating status, so the VOUT pin is set to the V<sub>SS</sub> level. For the ON / OFF pin current, refer to the B type of ON / OFF pin input current “H” in “■ **Electrical Characteristics**”.

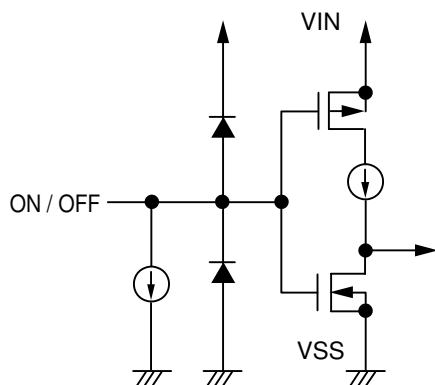
#### 3.2 S-11L10 Series D type

The ON / OFF pin is internally not pulled up or pulled down, so do not use this pin in the floating status. When not using the ON / OFF pin, connect it to the VIN pin.

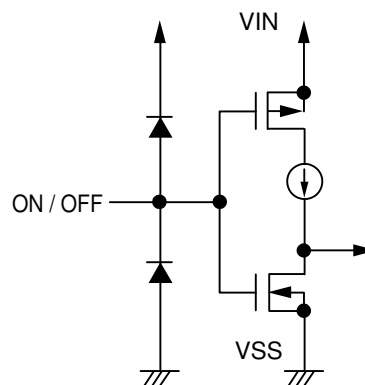
**Caution** Under high temperature in the S-11L10 Series, this IC’s current consumption may increase if applying voltage of 0.2 V to 0.9 V to the ON / OFF pin.

**Table 8**

Product Type	ON / OFF Pin	Internal Circuit	VOUT Pin Voltage	Current Consumption
B / D	“L”: OFF	Stop	V <sub>SS</sub> level	I <sub>SS2</sub>
B / D	“H”: ON	Operate	Set value	I <sub>SS1</sub>



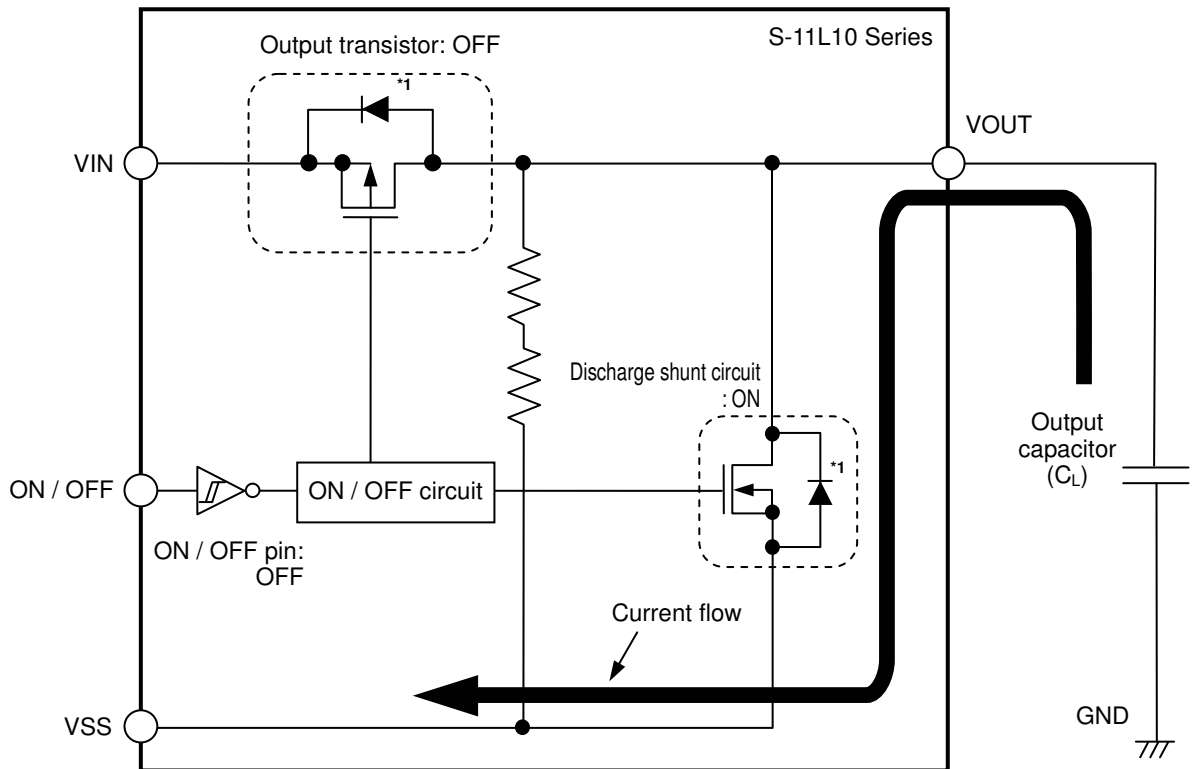
**Figure 14 S-11L10 Series B Type**



**Figure 15 S-11L10 Series D Type**

**4. Discharge shunt function**

The S-11L10 Series has a built-in discharge shunt circuit to discharge the output capacitance. When the ON / OFF pin is set to OFF level, turns the output transistor off, and turns the discharge shunt function on so that the output capacitor discharges. The VOUT pin is set to the  $V_{SS}$  level faster, compared to the product which does not have a discharge shunt circuit.



\*1. Parasitic diode

Figure 16



## 5. Overcurrent protection circuit

The S-11L10 Series includes an overcurrent protection circuit having the characteristics shown in “1. Output Voltage vs. Output Current (When Load Current Increases) (Ta = +25°C)” in “■ Characteristics (Typical Data)”, in order to protect the output transistor against an excessive output current and short circuiting between the VOUT pin and VSS pin. The current when the output pin is short-circuited ( $I_{short}$ ) is internally set at approx. 150 mA typ., and the normal value is restored for the output voltage, if releasing a short circuit once.

**Caution** This overcurrent protection circuit does not work as for thermal protection. If this IC long keeps short circuiting inside, pay attention to the conditions of input voltage and load current so that, under the usage conditions including short circuit, the loss of the IC will not exceed power dissipation of the package.

## 6. Constant current source pull-down (S-11L10 Series B type)

The ON / OFF pin is internally pulled down to the VSS pin in the floating status, so the VOUT pin is set to the  $V_{SS}$  level.

Note that the IC's current consumption increases as much as the constant current flows when the ON / OFF pin is connected to the VIN pin and the S-11L10 Series B type is operating.

## ■ Precautions

- Wiring patterns for the VIN pin, the VOUT pin and GND should be designed so that the impedance is low. When mounting an output capacitor between the VOUT pin and the VSS pin ( $C_L$ ) and a capacitor for stabilizing the input between the VIN pin and the VSS pin ( $C_{IN}$ ), the distance from the capacitors to these pins should be as short as possible.
- Note that generally the output voltage may increase when a series regulator is used at low load current (100  $\mu$ A or less).
- Note that generally the output voltage may increase due to the leakage current from an output driver when a series regulator is used at high temperature.
- At high temperature, the current consumption of the S-11L10 Series may increase if applying voltage of 0.2 V to 0.9 V to the ON / OFF pin.
- The S-11L10 Series may oscillate if power supply's inductance is high. Select an input capacitor after performing sufficient evaluation under the actual usage conditions including evaluation of temperature characteristics.
- Generally a series regulator may cause oscillation, depending on the selection of external parts. The following conditions are recommended for the S-11L10 Series. However, be sure to perform sufficient evaluation under the actual usage conditions for selection, including evaluation of temperature characteristics. Refer to "5. Example of Equivalent Series Resistance vs. Output Current Characteristics ( $T_a = +25^\circ\text{C}$ )" in "■ Reference Data" for the equivalent series resistance ( $R_{ESR}$ ) of the output capacitor.

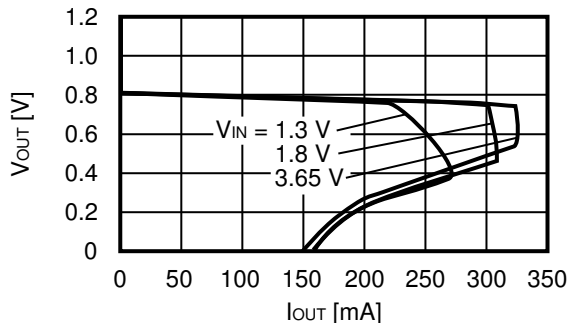
Input capacitor ( $C_{IN}$ ):	1.0 $\mu$ F or more
Output capacitor ( $C_L$ ):	1.0 $\mu$ F or more

- The voltage regulator may oscillate when the impedance of the power supply is high and the input capacitance is small or an input capacitor is not connected.
- If the output capacitance is small, power supply's fluctuation and the characteristics of load fluctuation become worse. Sufficiently evaluate the output voltage's fluctuation with the actual device.
- Overshoot may occur in the output voltage momentarily if the voltage is rapidly raised at power-on or when the power supply fluctuates. Sufficiently evaluate the output voltage at power-on with the actual device.
- The application conditions for the input voltage, the output voltage, and the load current should not exceed the package power dissipation.
- Do not apply an electrostatic discharge to this IC that exceeds the performance ratings of the built-in electrostatic protection circuit.
- In determining the output current, attention should be paid to the output current value specified in **Table 7** in "■ Electrical Characteristics" and footnote \*5 of the table.
- SII claims no responsibility for any disputes arising out of or in connection with any infringement by products including this IC of patents owned by a third party.

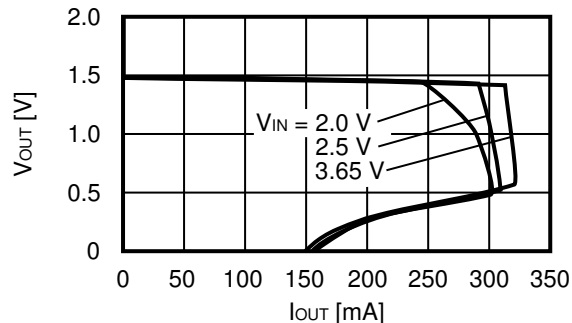
■ Characteristics (Typical Data)

1. Output Voltage vs. Output Current (When Load Current Increases) ( $T_a = +25^\circ\text{C}$ )

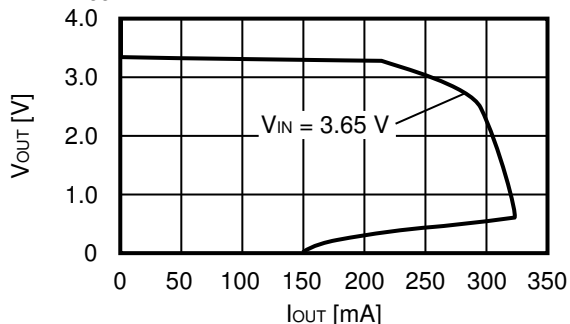
1.1  $V_{\text{OUT}} = 0.8\text{ V}$



1.2  $V_{\text{OUT}} = 1.5\text{ V}$



1.3  $V_{\text{OUT}} = 3.3\text{ V}$

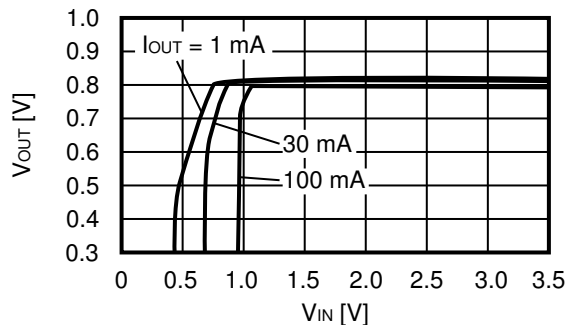


**Remark** In determining the output current, attention should be paid to the following.

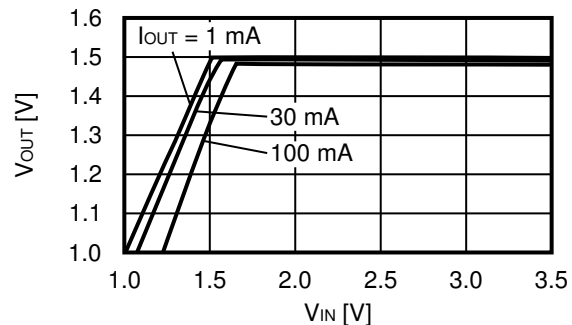
1. The minimum output current value and footnote \*5 in Table 7 in "■ Electrical Characteristics"
2. The package power dissipation

2. Output Voltage vs. Input Voltage ( $T_a = +25^\circ\text{C}$ )

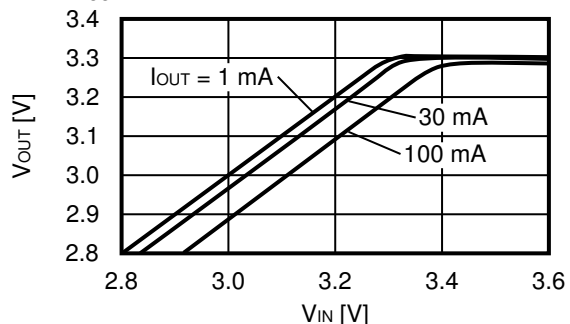
2.1  $V_{\text{OUT}} = 0.8\text{ V}$



2.2  $V_{\text{OUT}} = 1.5\text{ V}$

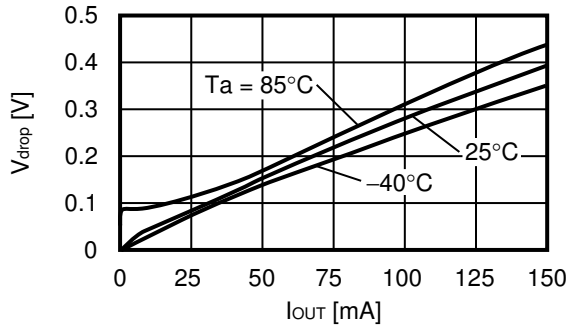


2.3  $V_{\text{OUT}} = 3.3\text{ V}$

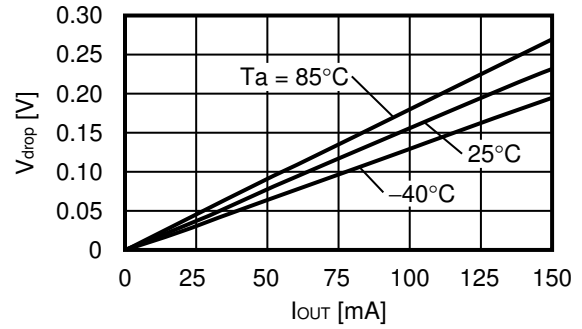


**3. Dropout Voltage vs. Output Current**

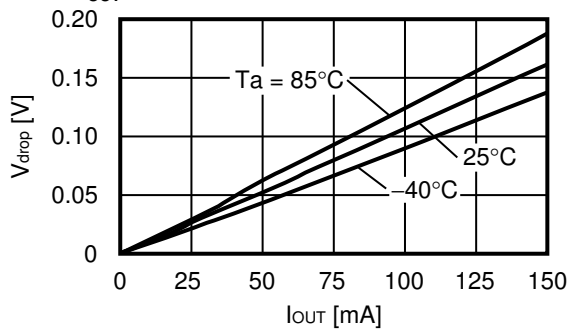
**3.1  $V_{OUT} = 0.8\text{ V}$**



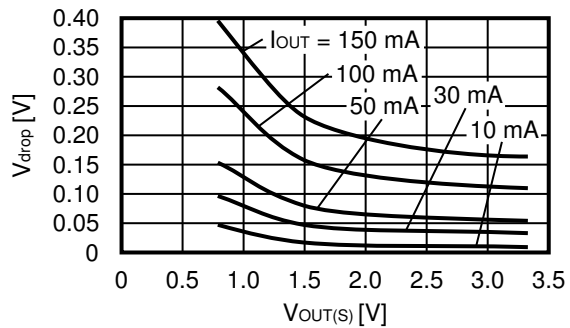
**3.2  $V_{OUT} = 1.5\text{ V}$**



**3.3  $V_{OUT} = 3.3\text{ V}$**

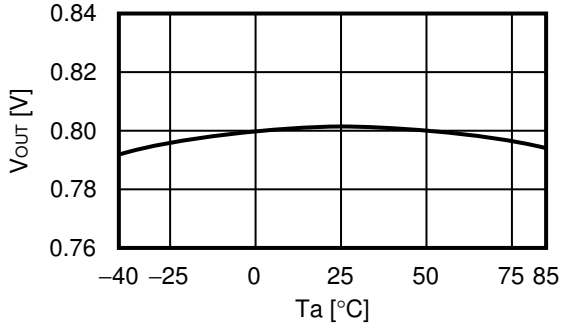


**4. Dropout Voltage vs. Set Output Voltage**

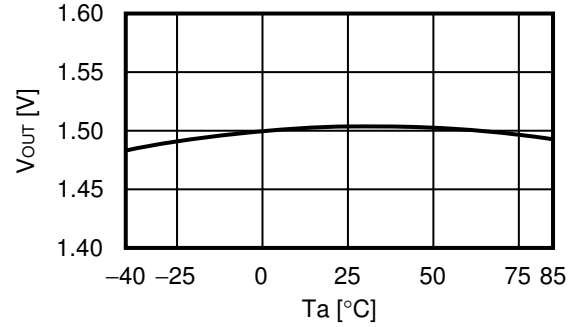


**5. Output Voltage vs. Ambient Temperature**

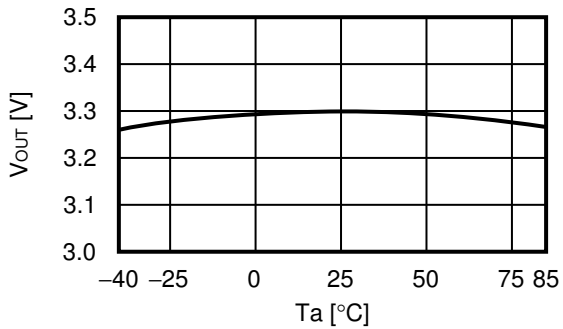
**5.1  $V_{OUT} = 0.8\text{ V}$**



**5.2  $V_{OUT} = 1.5\text{ V}$**

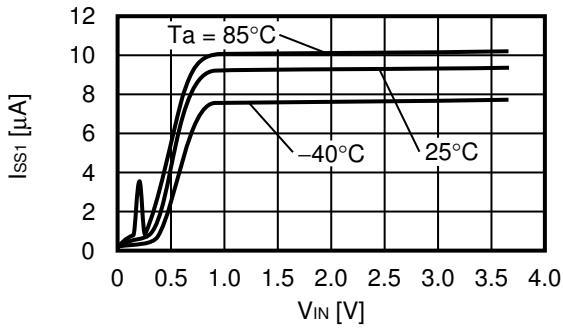


**5.3  $V_{OUT} = 3.3\text{ V}$**

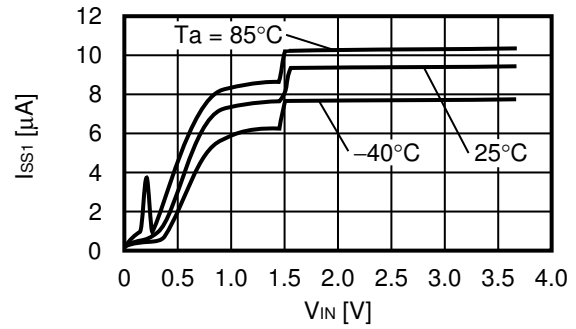


**6. Current Consumption vs. Input Voltage**

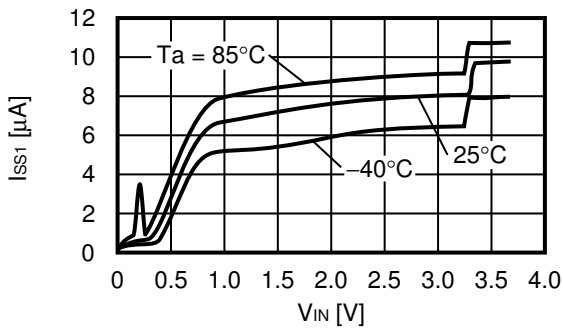
**6.1  $V_{OUT} = 0.8\text{ V}$**



**6.2  $V_{OUT} = 1.5\text{ V}$**

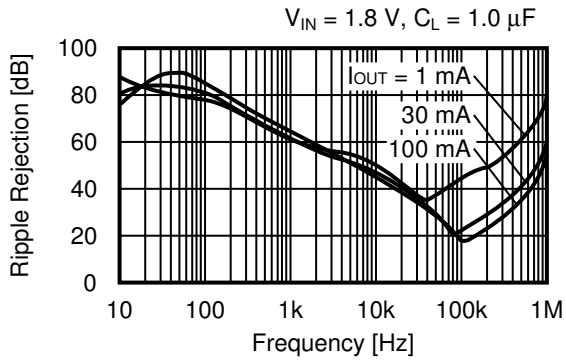


**6.3  $V_{OUT} = 3.3\text{ V}$**

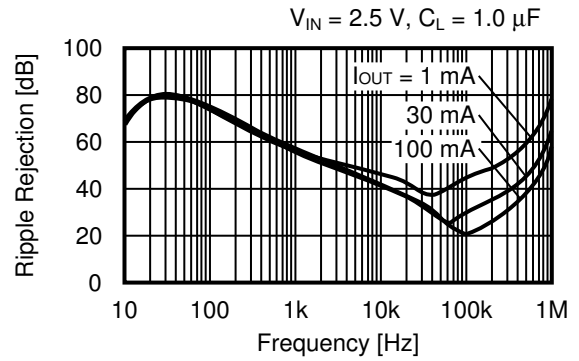


**7. Ripple Rejection ( $T_a = +25^\circ\text{C}$ )**

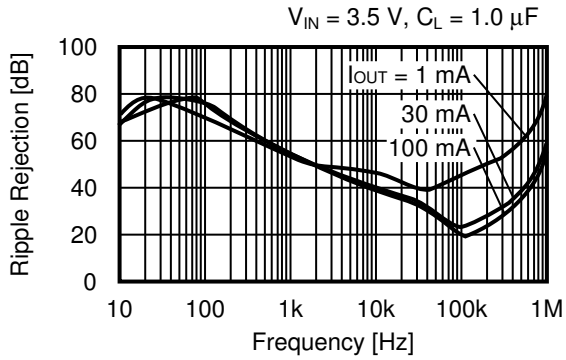
**7.1  $V_{OUT} = 0.8\text{ V}$**



**7.2  $V_{OUT} = 1.5\text{ V}$**



**7.3  $V_{OUT} = 2.5\text{ V}$**

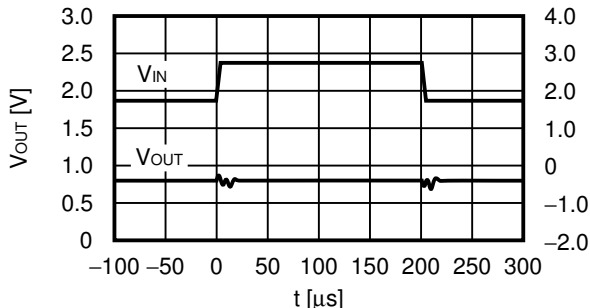


**■ Reference Data**

**1. Transient Response Characteristics when Input (Ta = +25°C)**

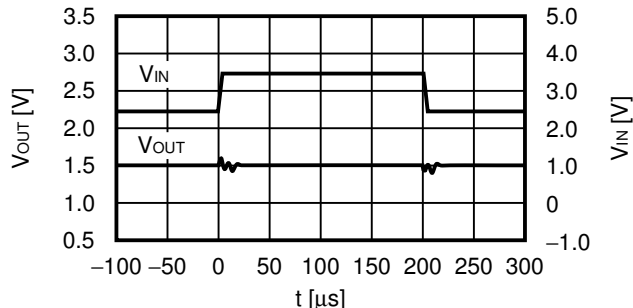
**1.1 V<sub>OUT</sub> = 0.8 V**

I<sub>OUT</sub> = 30 mA, t<sub>r</sub> = t<sub>f</sub> = 5.0 μs, C<sub>L</sub> = 1.0 μF, C<sub>IN</sub> = 1.0 μF



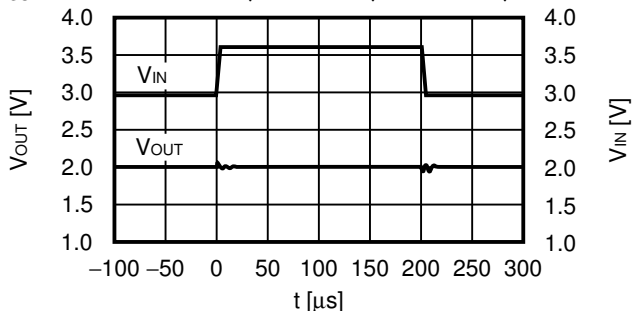
**1.2 V<sub>OUT</sub> = 1.5 V**

I<sub>OUT</sub> = 30 mA, t<sub>r</sub> = t<sub>f</sub> = 5.0 μs, C<sub>L</sub> = 1.0 μF, C<sub>IN</sub> = 1.0 μF



**1.3 V<sub>OUT</sub> = 2.0 V**

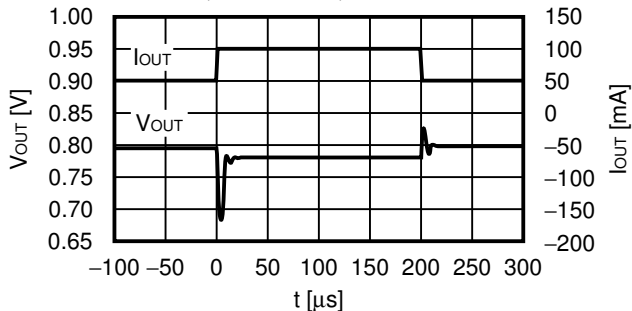
I<sub>OUT</sub> = 30 mA, t<sub>r</sub> = t<sub>f</sub> = 5.0 μs, C<sub>L</sub> = 1.0 μF, C<sub>IN</sub> = 1.0 μF



**2. Transient Response Characteristics of Load (Ta = +25°C)**

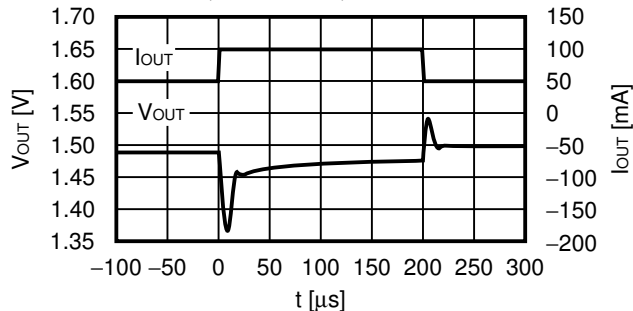
**2.1 V<sub>OUT</sub> = 0.8 V**

V<sub>IN</sub> = 1.8 V, C<sub>L</sub> = 1.0 μF, C<sub>IN</sub> = 1.0 μF, I<sub>OUT</sub> = 50 mA ↔ 100 mA



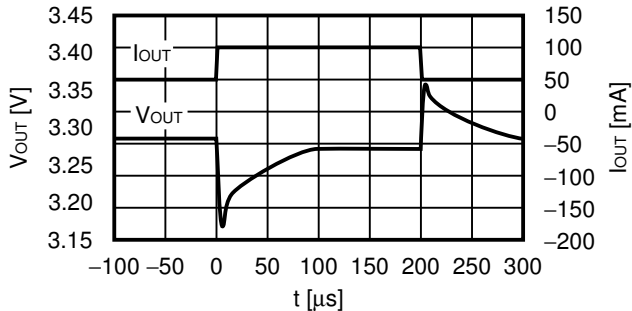
**2.2 V<sub>OUT</sub> = 1.5 V**

V<sub>IN</sub> = 2.5 V, C<sub>L</sub> = 1.0 μF, C<sub>IN</sub> = 1.0 μF, I<sub>OUT</sub> = 50 mA ↔ 100 mA



**2.3 V<sub>OUT</sub> = 3.3 V**

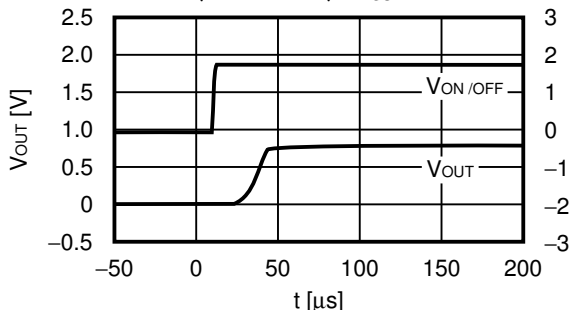
V<sub>IN</sub> = 3.65 V, C<sub>L</sub> = 1.0 μF, C<sub>IN</sub> = 1.0 μF, I<sub>OUT</sub> = 50 mA ↔ 100 mA



**3. Transient Response Characteristics of ON / OFF Pin (Ta = +25°C)**

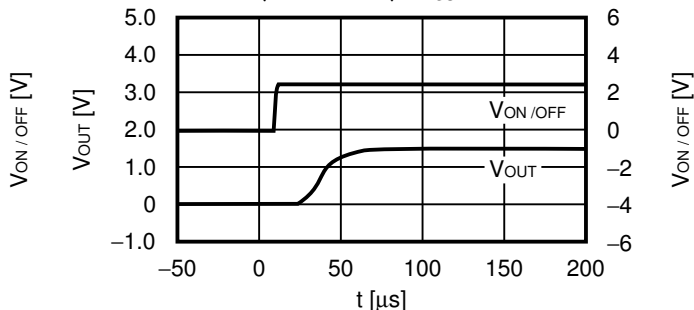
**3.1 V<sub>OUT</sub> = 0.8 V**

V<sub>IN</sub> = 1.8 V, C<sub>L</sub> = 1.0 μF, C<sub>IN</sub> = 1.0 μF, I<sub>OUT</sub> = 100 mA



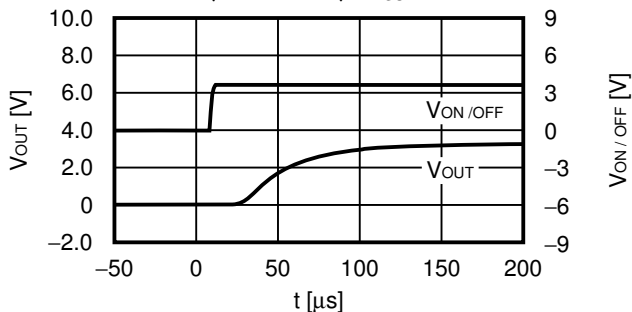
**3.2 V<sub>OUT</sub> = 1.5 V**

V<sub>IN</sub> = 2.5 V, C<sub>L</sub> = 1.0 μF, C<sub>IN</sub> = 1.0 μF, I<sub>OUT</sub> = 100 mA



**3.3 V<sub>OUT</sub> = 3.3 V**

V<sub>IN</sub> = 3.65 V, C<sub>L</sub> = 1.0 μF, C<sub>IN</sub> = 1.0 μF, I<sub>OUT</sub> = 100 mA



**4. Output Capacitance vs. Characteristics of Discharge Time (Ta = +25°C)**

V<sub>IN</sub> = V<sub>OUT</sub> + 1.0 V (max.: 3.65 V), I<sub>OUT</sub> = no load

V<sub>ON/OFF</sub> = V<sub>OUT</sub> + 1.0 V → V<sub>SS</sub>, t<sub>i</sub> = 1 μs

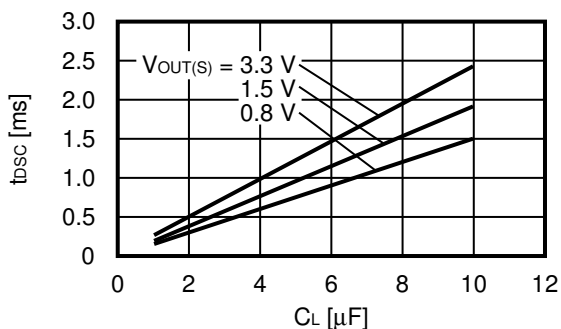


Figure 17

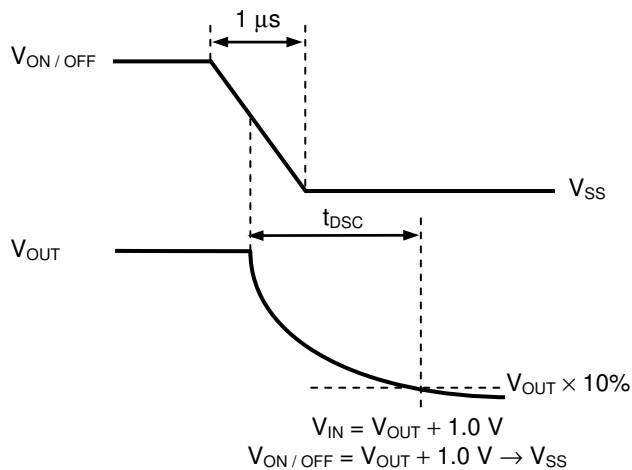
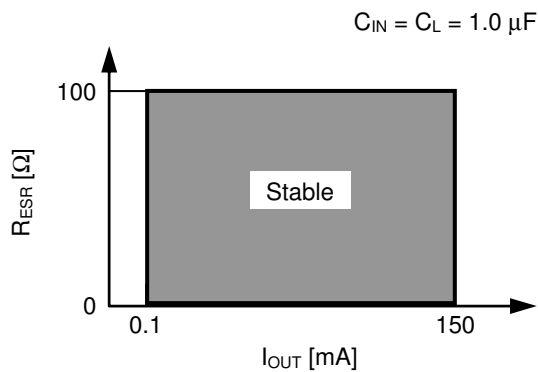


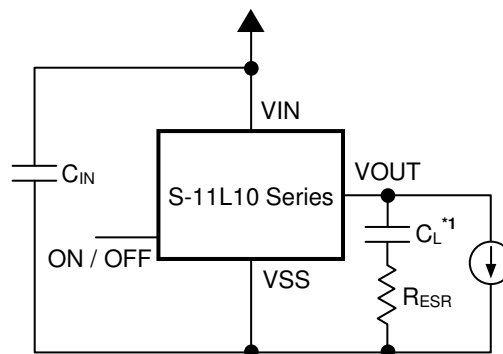
Figure 18 Measurement Condition of Discharge Time



**5. Example of Equivalent Series Resistance vs. Output Current Characteristics (Ta = +25°C)**



**Figure 19**

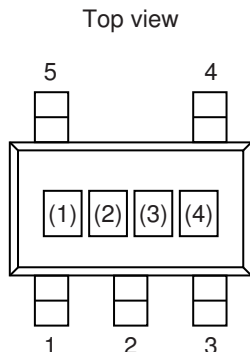


\*1.  $C_L$ : TDK Corporation C3216X8R1E105K (1.0  $\mu F$ )

**Figure 20**

■ **Marking Specifications**

**1. SOT-23-5**



(1) to (3) : Product code (Refer to **Product name vs. Product code**)  
 (4) : Lot number

**Product name vs. Product code**

**1.1 S-11L10 Series B type**

Product Name	Product code		
	(1)	(2)	(3)
S-11L10B08-M5T1U	T	V	A
S-11L10B09-M5T1U	T	V	B
S-11L10B10-M5T1U	T	V	C
S-11L10B11-M5T1U	T	V	D
S-11L10B12-M5T1U	T	V	E
S-11L10B13-M5T1U	T	V	F
S-11L10B14-M5T1U	T	V	G
S-11L10B15-M5T1U	T	V	H
S-11L10B16-M5T1U	T	V	I
S-11L10B17-M5T1U	T	V	J
S-11L10B18-M5T1U	T	V	K
S-11L10B19-M5T1U	T	V	L
S-11L10B20-M5T1U	T	V	M
S-11L10B21-M5T1U	T	V	N
S-11L10B22-M5T1U	T	V	O
S-11L10B23-M5T1U	T	V	P
S-11L10B24-M5T1U	T	V	Q
S-11L10B25-M5T1U	T	V	R
S-11L10B26-M5T1U	T	V	S
S-11L10B27-M5T1U	T	V	T
S-11L10B28-M5T1U	T	V	U
S-11L10B29-M5T1U	T	V	V
S-11L10B30-M5T1U	T	V	W
S-11L10B31-M5T1U	T	V	X
S-11L10B32-M5T1U	T	V	Y
S-11L10B33-M5T1U	T	V	Z

**1.2 S-11L10 Series D type**

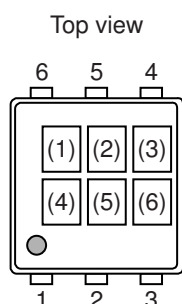
Product Name	Product code		
	(1)	(2)	(3)
S-11L10D08-M5T1U	T	X	A
S-11L10D09-M5T1U	T	X	B
S-11L10D10-M5T1U	T	X	C
S-11L10D11-M5T1U	T	X	D
S-11L10D12-M5T1U	T	X	E
S-11L10D13-M5T1U	T	X	F
S-11L10D14-M5T1U	T	X	G
S-11L10D15-M5T1U	T	X	H
S-11L10D16-M5T1U	T	X	I
S-11L10D17-M5T1U	T	X	J
S-11L10D18-M5T1U	T	X	K
S-11L10D19-M5T1U	T	X	L
S-11L10D20-M5T1U	T	X	M
S-11L10D21-M5T1U	T	X	N
S-11L10D22-M5T1U	T	X	O
S-11L10D23-M5T1U	T	X	P
S-11L10D24-M5T1U	T	X	Q
S-11L10D25-M5T1U	T	X	R
S-11L10D26-M5T1U	T	X	S
S-11L10D27-M5T1U	T	X	T
S-11L10D28-M5T1U	T	X	U
S-11L10D29-M5T1U	T	X	V
S-11L10D30-M5T1U	T	X	W
S-11L10D31-M5T1U	T	X	X
S-11L10D32-M5T1U	T	X	Y
S-11L10D33-M5T1U	T	X	Z

# SUPER-LOW OUTPUT VOLTAGE LOW DROPOUT CMOS VOLTAGE REGULATOR

Rev.2.1\_00

**S-11L10 Series**

## 2. SNT-6A(H)



(1) to (3) : Product code (Refer to **Product name vs. Product code**)  
 (4) to (6) : Lot number

### Product name vs. Product code

#### 2.1 S-11L10 Series B type

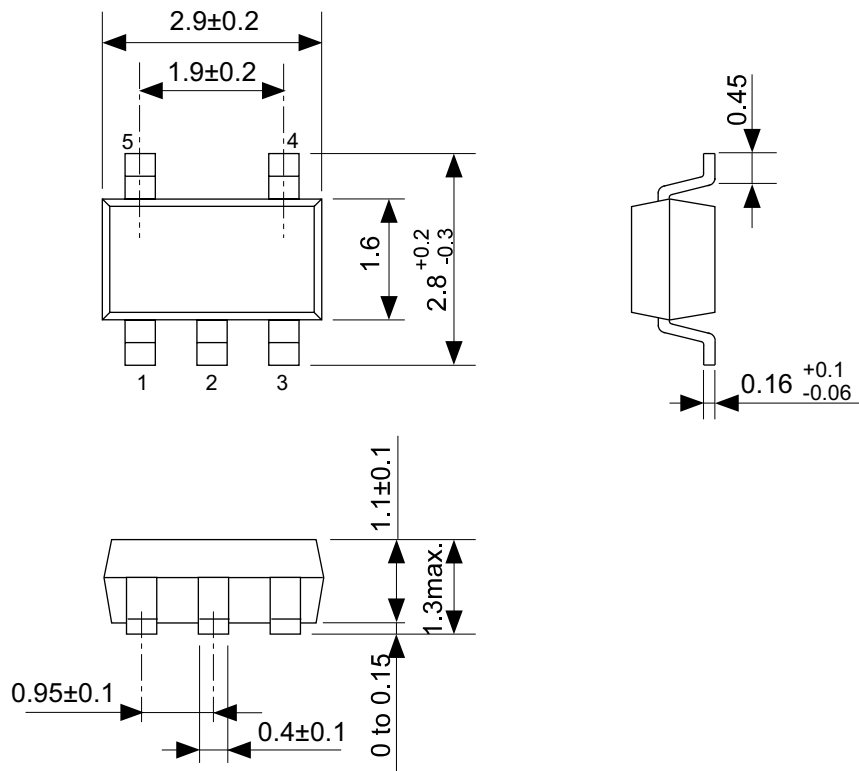
Product Name	Product code		
	(1)	(2)	(3)
S-11L10B08-I6T2x	T	V	A
S-11L10B09-I6T2x	T	V	B
S-11L10B10-I6T2x	T	V	C
S-11L10B11-I6T2x	T	V	D
S-11L10B12-I6T2x	T	V	E
S-11L10B13-I6T2x	T	V	F
S-11L10B14-I6T2x	T	V	G
S-11L10B15-I6T2x	T	V	H
S-11L10B16-I6T2x	T	V	I
S-11L10B17-I6T2x	T	V	J
S-11L10B18-I6T2x	T	V	K
S-11L10B19-I6T2x	T	V	L
S-11L10B20-I6T2x	T	V	M
S-11L10B21-I6T2x	T	V	N
S-11L10B22-I6T2x	T	V	O
S-11L10B23-I6T2x	T	V	P
S-11L10B24-I6T2x	T	V	Q
S-11L10B25-I6T2x	T	V	R
S-11L10B26-I6T2x	T	V	S
S-11L10B27-I6T2x	T	V	T
S-11L10B28-I6T2x	T	V	U
S-11L10B29-I6T2x	T	V	V
S-11L10B30-I6T2x	T	V	W
S-11L10B31-I6T2x	T	V	X
S-11L10B32-I6T2x	T	V	Y
S-11L10B33-I6T2x	T	V	Z

#### 2.2 S-11L10 Series D type

Product Name	Product code		
	(1)	(2)	(3)
S-11L10D08-I6T2x	T	X	A
S-11L10D09-I6T2x	T	X	B
S-11L10D10-I6T2x	T	X	C
S-11L10D11-I6T2x	T	X	D
S-11L10D12-I6T2x	T	X	E
S-11L10D13-I6T2x	T	X	F
S-11L10D14-I6T2x	T	X	G
S-11L10D15-I6T2x	T	X	H
S-11L10D16-I6T2x	T	X	I
S-11L10D17-I6T2x	T	X	J
S-11L10D18-I6T2x	T	X	K
S-11L10D19-I6T2x	T	X	L
S-11L10D20-I6T2x	T	X	M
S-11L10D21-I6T2x	T	X	N
S-11L10D22-I6T2x	T	X	O
S-11L10D23-I6T2x	T	X	P
S-11L10D24-I6T2x	T	X	Q
S-11L10D25-I6T2x	T	X	R
S-11L10D26-I6T2x	T	X	S
S-11L10D27-I6T2x	T	X	T
S-11L10D28-I6T2x	T	X	U
S-11L10D29-I6T2x	T	X	V
S-11L10D30-I6T2x	T	X	W
S-11L10D31-I6T2x	T	X	X
S-11L10D32-I6T2x	T	X	Y
S-11L10D33-I6T2x	T	X	Z

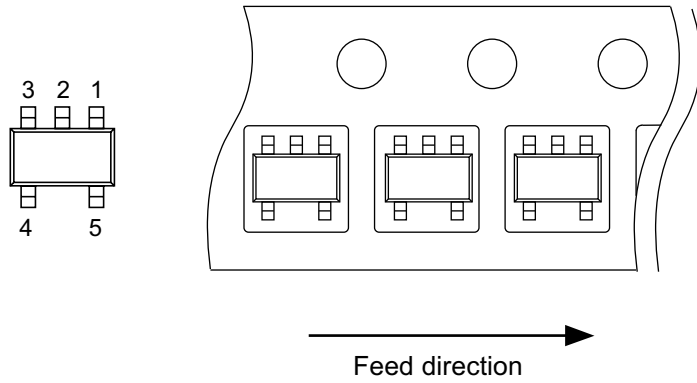
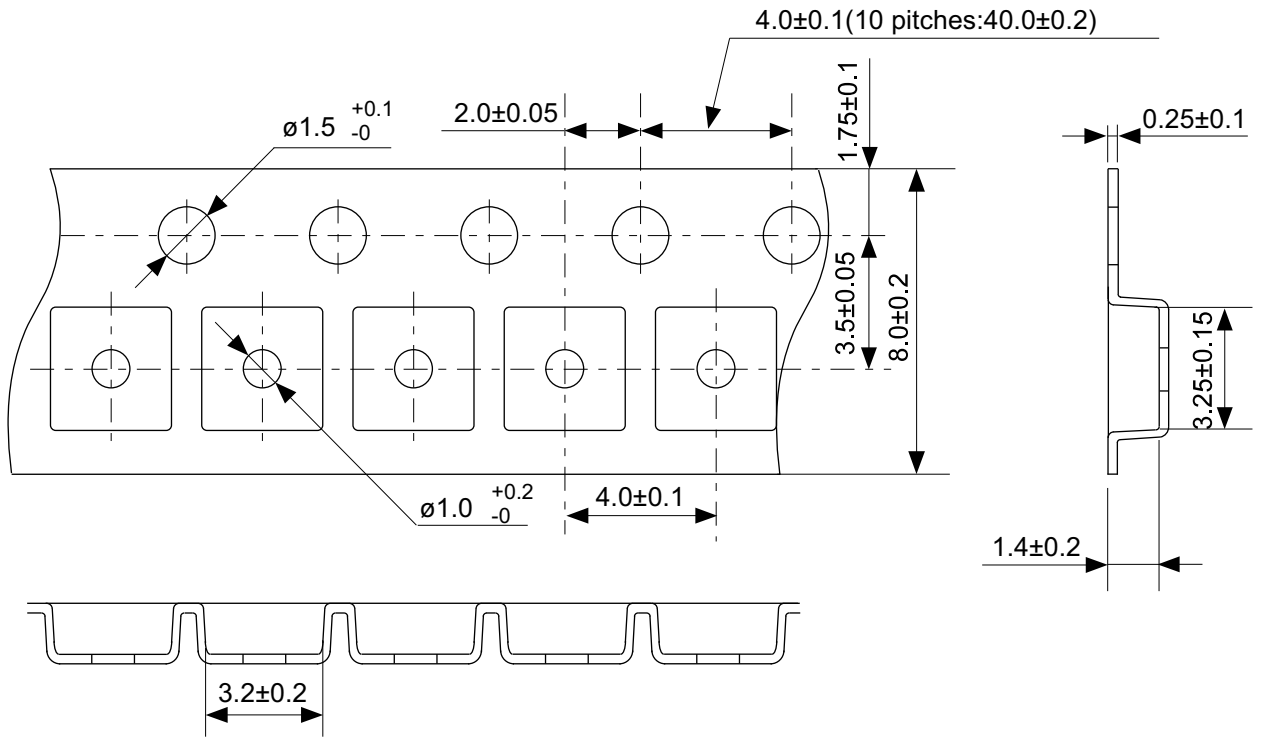
**Remark 1.** x: G or U

**2.** Please select products of environmental code = U for Sn 100%, halogen-free products.



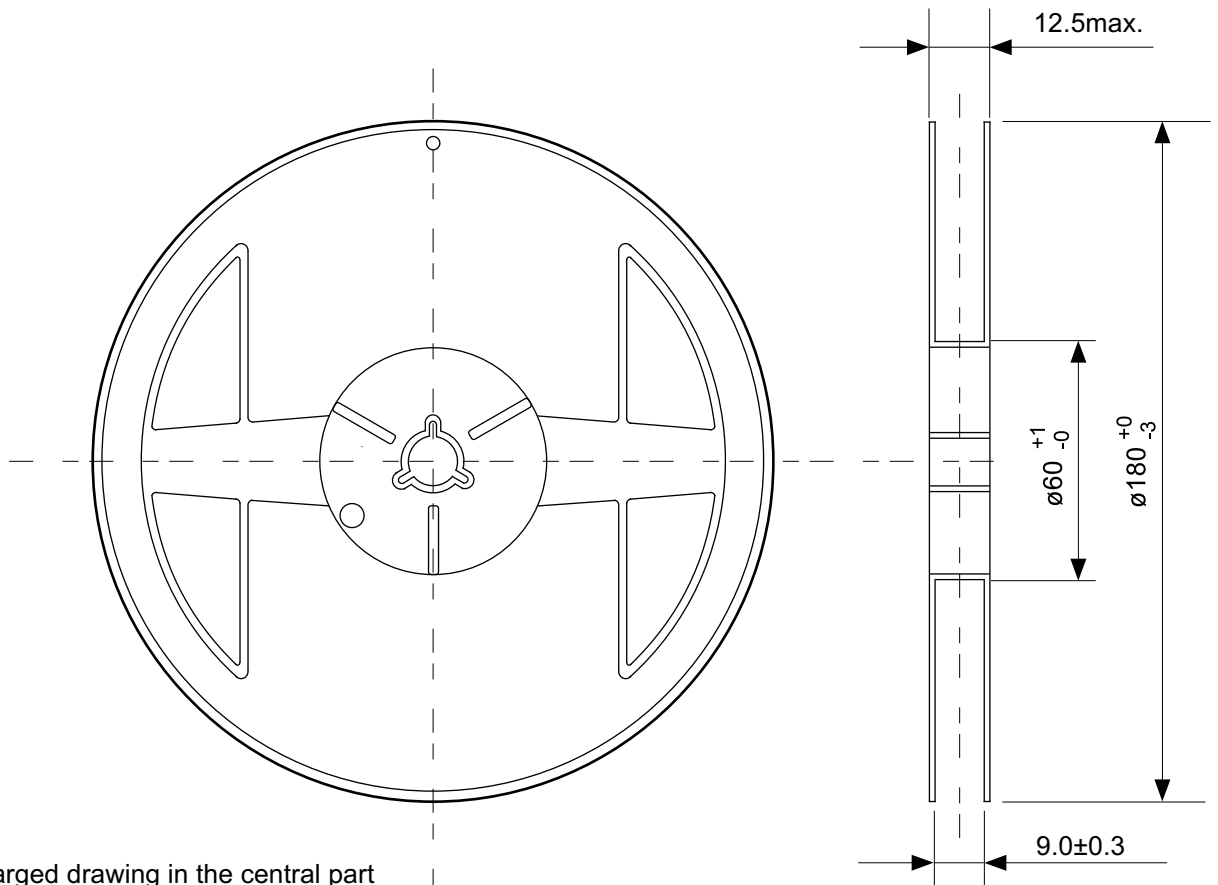
No. MP005-A-P-SD-1.2

TITLE	SOT235-A-PKG Dimensions
No.	MP005-A-P-SD-1.2
SCALE	
UNIT	mm
Seiko Instruments Inc.	

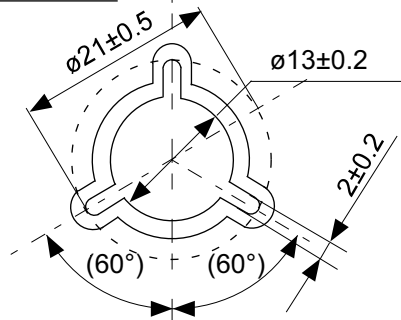


No. MP005-A-C-SD-2.1

TITLE	SOT235-A-Carrier Tape
No.	MP005-A-C-SD-2.1
SCALE	
UNIT	mm
Seiko Instruments Inc.	

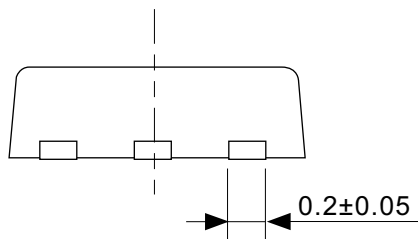
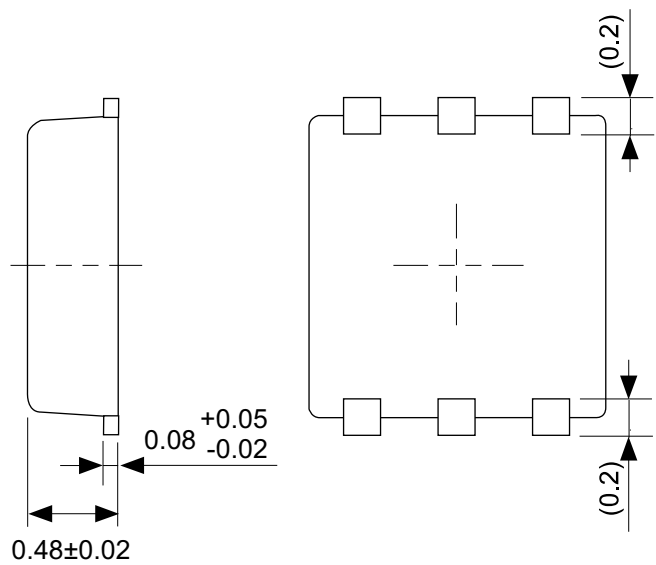
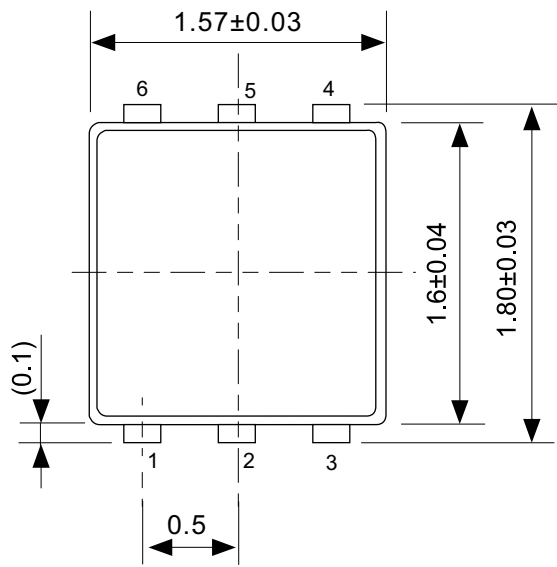


Enlarged drawing in the central part



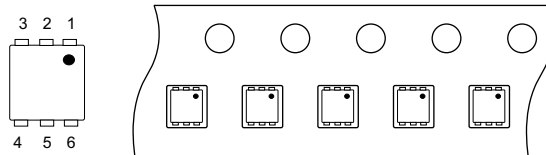
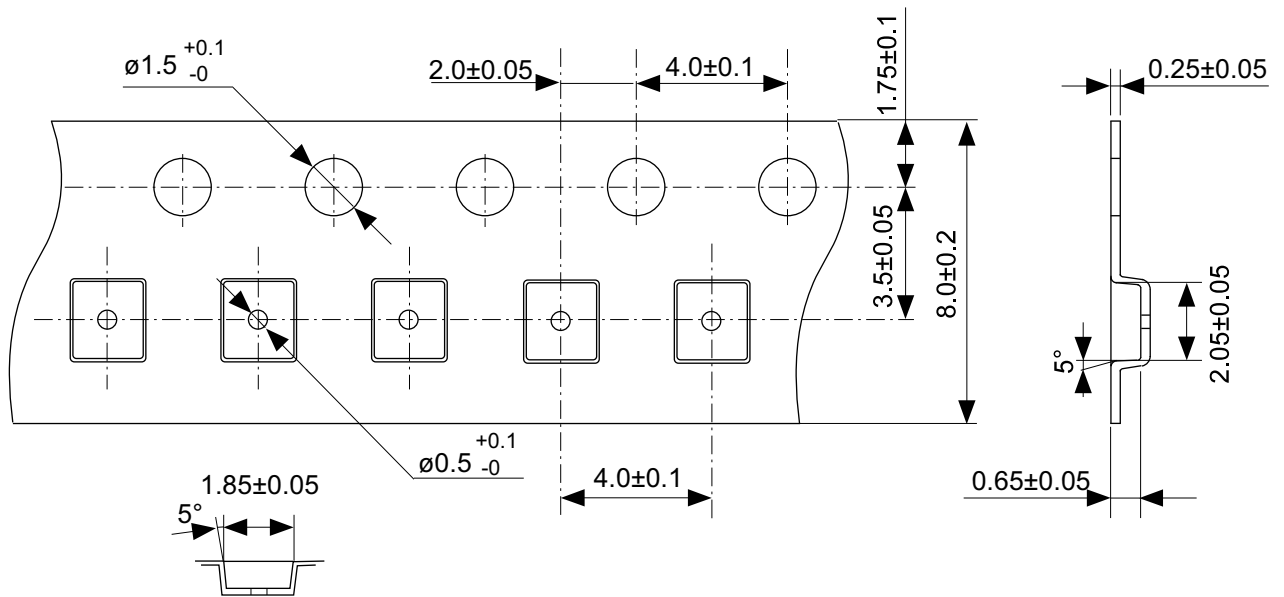
No. MP005-A-R-SD-1.1

TITLE	SOT235-A-Reel		
No.	MP005-A-R-SD-1.1		
SCALE		QTY.	3,000
UNIT	mm		
Seiko Instruments Inc.			



No. PI006-A-P-SD-2.0

TITLE	SNT-6A(H)-A-PKG Dimensions
No.	PI006-A-P-SD-2.0
SCALE	
UNIT	mm
Seiko Instruments Inc.	

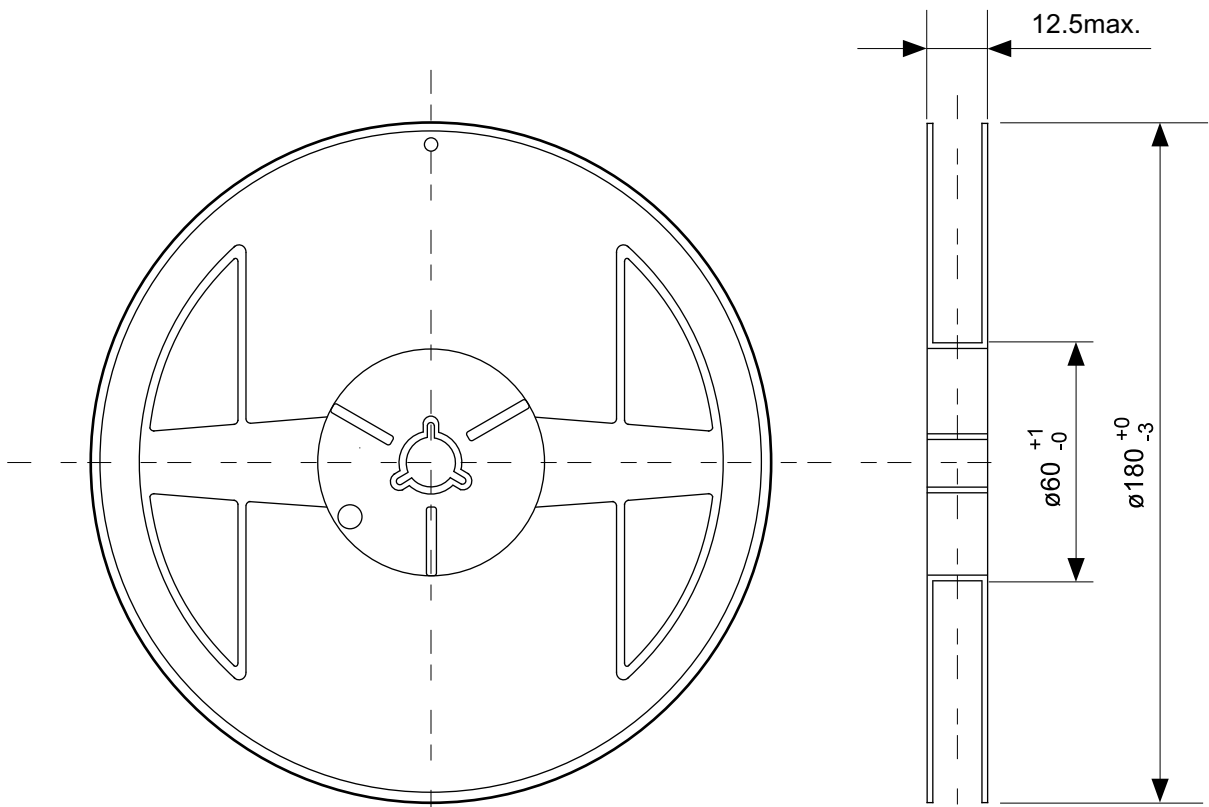


→  
Feed direction

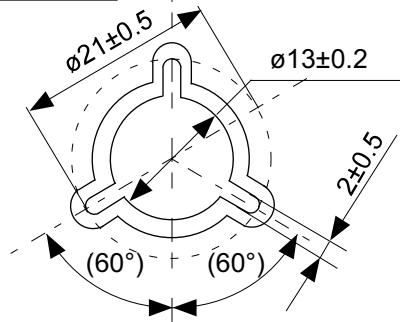
No. PI006-A-C-SD-1.0

TITLE	SNT-6A(H)-A-Carrier Tape
No.	PI006-A-C-SD-1.0
SCALE	
UNIT	mm
Seiko Instruments Inc.	



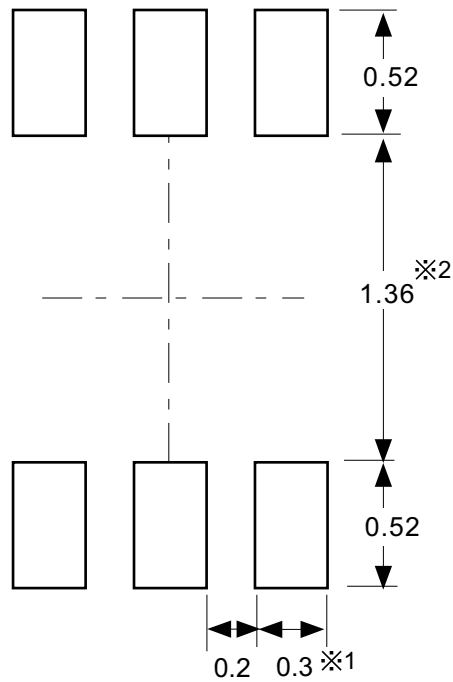


Enlarged drawing in the central part



No. PI006-A-R-SD-1.0

TITLE	SNT-6A(H)-A-Reel		
No.	PI006-A-R-SD-1.0		
SCALE		QTY.	5,000
UNIT	mm		
Seiko Instruments Inc.			



※1. ランドパターンの幅に注意してください (0.25 mm min. / 0.30 mm typ.).

※2. パッケージ中央にランドパターンを広げないでください (1.30 mm ~ 1.40 mm)。

- 注意
1. パッケージのモールド樹脂下にシルク印刷やハンダ印刷などしないでください。
  2. パッケージ下の配線上のソルダーレジストなどの厚みをランドパターン表面から0.03 mm以下にしてください。
  3. マスク開口サイズと開口位置はランドパターンと合わせてください。
  4. 詳細は "SNTパッケージ活用の手引き" を参照してください。

※1. Pay attention to the land pattern width (0.25 mm min. / 0.30 mm typ.).

※2. Do not widen the land pattern to the center of the package (1.30 mm to 1.40 mm).

- Caution**
1. Do not do silkscreen printing and solder printing under the mold resin of the package.
  2. The thickness of the solder resist on the wire pattern under the package should be 0.03 mm or less from the land pattern surface.
  3. Match the mask aperture size and aperture position with the land pattern.
  4. Refer to "SNT Package User's Guide" for details.

※1. 请注意焊盘模式的宽度 (0.25 mm min. / 0.30 mm typ.)。

※2. 请勿向封装中间扩展焊盘模式 (1.30 mm ~ 1.40 mm)。

- 注意
1. 请勿在树脂型封装的下面印刷丝网、焊锡。
  2. 在封装下、布线上的阻焊膜厚度 (从焊盘模式表面起) 请控制在0.03 mm以下。
  3. 掩膜的开口尺寸和开口位置请与焊盘模式对齐。
  4. 详细内容请参阅 "SNT封装的应用指南"。

No. PI006-A-L-SD-4.0

TITLE	SNT-6A(H)-A-Land Recommendation
No.	PI006-A-L-SD-4.0
SCALE	
UNIT	mm
Seiko Instruments Inc.	



Seiko Instruments Inc.  
[www.sii-ic.com](http://www.sii-ic.com)

- The information described herein is subject to change without notice.
- Seiko Instruments Inc. is not responsible for any problems caused by circuits or diagrams described herein whose related industrial properties, patents, or other rights belong to third parties. The application circuit examples explain typical applications of the products, and do not guarantee the success of any specific mass-production design.
- When the products described herein are regulated products subject to the Wassenaar Arrangement or other agreements, they may not be exported without authorization from the appropriate governmental authority.
- Use of the information described herein for other purposes and/or reproduction or copying without the express permission of Seiko Instruments Inc. is strictly prohibited.
- The products described herein cannot be used as part of any device or equipment affecting the human body, such as exercise equipment, medical equipment, security systems, gas equipment, vehicle equipment, in-vehicle equipment, aviation equipment, aerospace equipment, and nuclear-related equipment, without prior written permission of Seiko Instruments Inc.
- The products described herein are not designed to be radiation-proof.
- Although Seiko Instruments Inc. exerts the greatest possible effort to ensure high quality and reliability, the failure or malfunction of semiconductor products may occur. The user of these products should therefore give thorough consideration to safety design, including redundancy, fire-prevention measures, and malfunction prevention, to prevent any accidents, fires, or community damage that may ensue.