

## LOW CURRENT CONSUMPTION HIGH RIPPLE-REJECTION LOW DROPOUT CMOS VOLTAGE REGULATOR

[www.sii-ic.com](http://www.sii-ic.com)

© Seiko Instruments Inc., 2011-2013

Rev.2.2\_00

The S-1312 Series, developed by using the CMOS technology, is a positive voltage regulator IC which has low current consumption, high ripple-rejection and low dropout voltage.

Even with low current consumption of 20  $\mu\text{A}$  typ., it has high ripple-rejection of 75 dB typ., and a ceramic capacitor of 0.22  $\mu\text{F}$  or more can be used as the input and output capacitors.

It also has high-accuracy output voltage of  $\pm 1.0\%$ .

### ■ Features

- Output voltage: 1.0 V to 3.5 V, selectable in 0.05 V step
- Input voltage: 1.5 V to 5.5 V
- Output voltage accuracy:  $\pm 1.0\%$  (1.0 V to 1.45 V output product:  $\pm 15$  mV)
- Dropout voltage: 160 mV typ. (2.8 V output product,  $I_{\text{OUT}} = 100$  mA)
- Current consumption:
  - During operation: 20  $\mu\text{A}$  typ., 30  $\mu\text{A}$  max.
  - During power-off: 0.1  $\mu\text{A}$  typ., 1.0  $\mu\text{A}$  max.
- Output current: Possible to output 150 mA ( $V_{\text{IN}} \geq V_{\text{OUT(S)}} + 1.0$  V)\*\*1
- Input and output capacitors: A ceramic capacitor of 0.22  $\mu\text{F}$  or more can be used.
- Ripple rejection:
  - 75 dB typ. (1.2 V output product,  $f = 1.0$  kHz)
  - 70 dB typ. (2.85 V output product,  $f = 1.0$  kHz)
- Built-in overcurrent protection circuit: Limits overcurrent of output transistor.
- Built-in thermal shutdown circuit: Prevents damage caused by heat.
- Built-in ON / OFF circuit: Ensures long battery life.
- Pull-down resistor is selectable.
- Discharge shunt function is selectable.
- Operation temperature range:  $T_a = -40^\circ\text{C}$  to  $+85^\circ\text{C}$
- Lead-free (Sn 100%), halogen-free

\*1. Attention should be paid to the power dissipation of the package when the output current is large.

### ■ Applications

- Constant-voltage power supply for portable communication device, digital camera, and digital audio player
- Constant-voltage power supply for battery-powered device
- Constant-voltage power supply for home electric appliance

### ■ Packages

- SOT-23-5
- HSNT-4 (1010)
- HSNT-4 (0808)

■ **Block Diagrams**

1. **S-1312 Series A type**

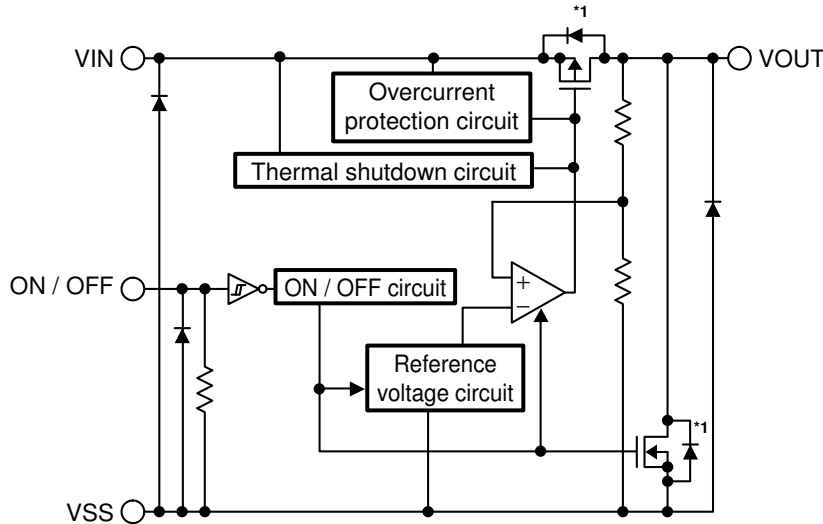

Function	Status
ON / OFF logic	Active "H"
Discharge shunt function	Available
Pull-down resistor	Available

\*1. Parasitic diode

Figure 1

2. **S-1312 Series B type**

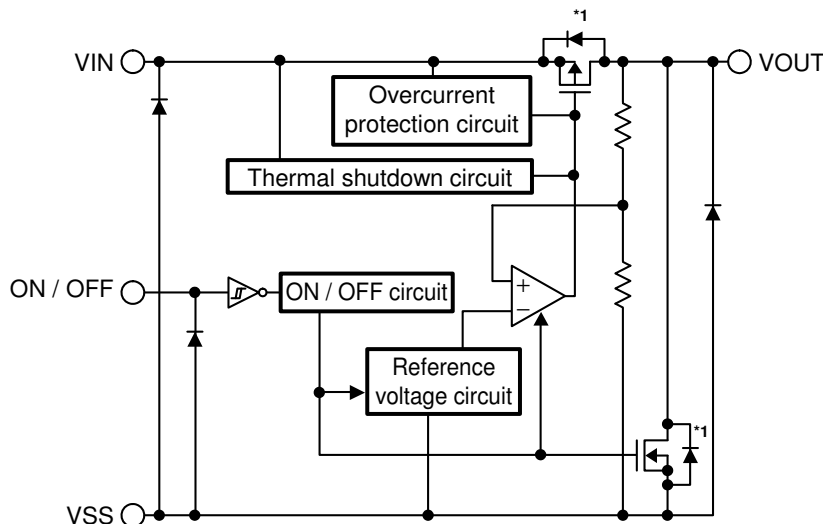

Function	Status
ON / OFF logic	Active "H"
Discharge shunt function	Available
Pull-down resistor	Unavailable

\*1. Parasitic diode

Figure 2

3. S-1312 Series C type

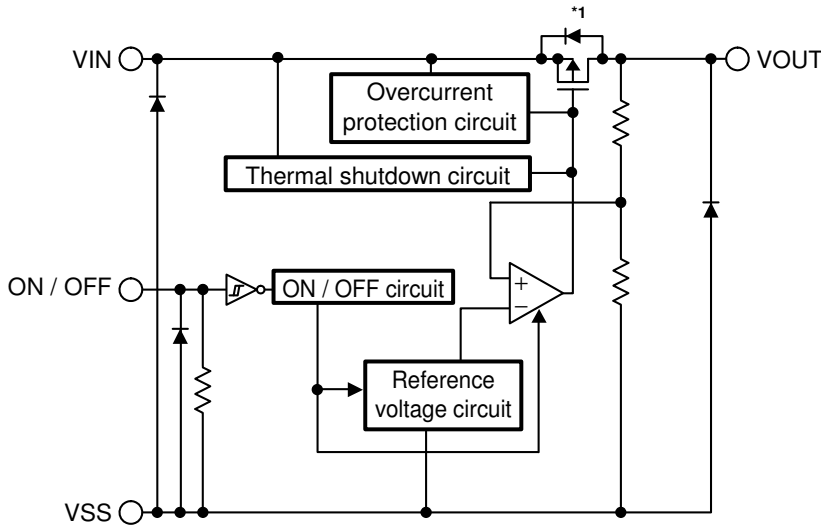

Function	Status
ON / OFF logic	Active "H"
Discharge shunt function	Unavailable
Pull-down resistor	Available

\*1. Parasitic diode

Figure 3

4. S-1312 Series D type

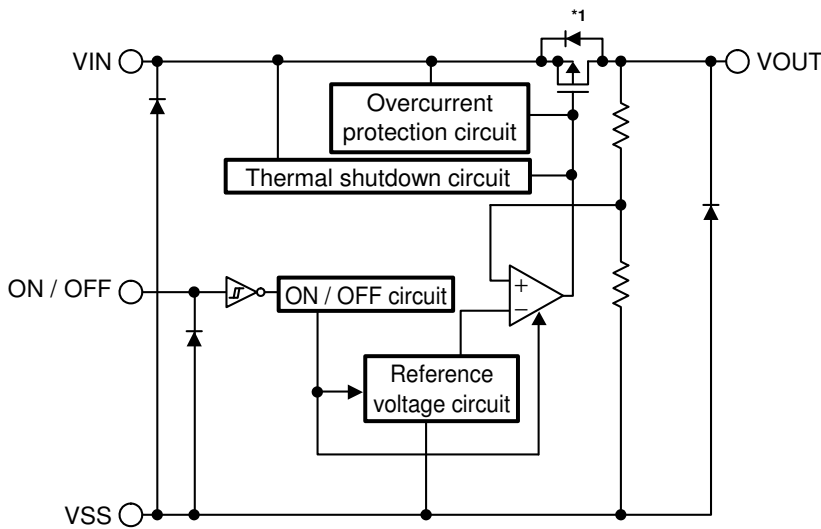

Function	Status
ON / OFF logic	Active "H"
Discharge shunt function	Unavailable
Pull-down resistor	Unavailable

\*1. Parasitic diode

Figure 4

## ■ Product Name Structure

Users can select the product type, output voltage, and package type for the S-1312 Series. Refer to "1. Product name" regarding the contents of product name, "2. Function list of product types" regarding the product type, "3. Packages" regarding the package drawings, "4. Product name lists" regarding details of the product name.

### 1. Product name

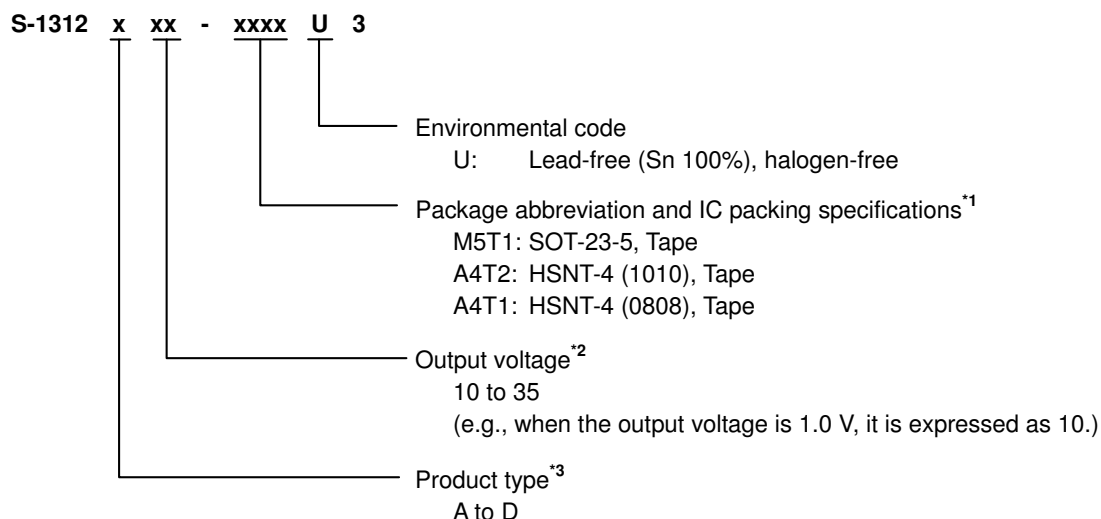

\*1. Refer to the tape drawing.

\*2. If you request the product which has 0.05 V step, contact our sales office.

\*3. Refer to "2. Function list of product types".

### 2. Function list of product types

Table 1

Product Type	ON / OFF Logic	Discharge Shunt Function	Pull-down Resistor
A	Active "H"	Available	Available
B	Active "H"	Available	Unavailable
C	Active "H"	Unavailable	Available
D	Active "H"	Unavailable	Unavailable

### 3. Packages

Table 2 Package Drawing Codes

Package Name	Dimension	Tape	Reel	Land
SOT-23-5	MP005-A-P-SD	MP005-A-C-SD	MP005-A-R-SD	—
HSNT-4 (1010)	PL004-A-P-SD	PL004-A-C-SD	PL004-A-R-SD	PL004-A-L-SD
HSNT-4 (0808)	PK004-A-P-SD	PK004-A-C-SD	PK004-A-R-SD	PK004-A-L-SD

4. Product name lists

4.1 S-1312 Series A type

ON / OFF logic: Active "H"  
 Discharge shunt function: Available Pull-down resistor: Available

Table 3

Output Voltage	SOT-23-5	HSNT-4 (1010)	HSNT-4 (0808)
1.0 V ± 15 mV	S-1312A10-M5T1U3	S-1312A10-A4T2U3	S-1312A10-A4T1U3
1.1 V ± 15 mV	S-1312A11-M5T1U3	S-1312A11-A4T2U3	S-1312A11-A4T1U3
1.2 V ± 15 mV	S-1312A12-M5T1U3	S-1312A12-A4T2U3	S-1312A12-A4T1U3
1.25 V ± 15 mV	S-1312A1C-M5T1U3	S-1312A1C-A4T2U3	S-1312A1C-A4T1U3
1.3 V ± 15 mV	S-1312A13-M5T1U3	S-1312A13-A4T2U3	S-1312A13-A4T1U3
1.4 V ± 15 mV	S-1312A14-M5T1U3	S-1312A14-A4T2U3	S-1312A14-A4T1U3
1.5 V ± 1.0%	S-1312A15-M5T1U3	S-1312A15-A4T2U3	S-1312A15-A4T1U3
1.6 V ± 1.0%	S-1312A16-M5T1U3	S-1312A16-A4T2U3	S-1312A16-A4T1U3
1.7 V ± 1.0%	S-1312A17-M5T1U3	S-1312A17-A4T2U3	S-1312A17-A4T1U3
1.8 V ± 1.0%	S-1312A18-M5T1U3	S-1312A18-A4T2U3	S-1312A18-A4T1U3
1.85 V ± 1.0%	S-1312A1J-M5T1U3	S-1312A1J-A4T2U3	S-1312A1J-A4T1U3
1.9 V ± 1.0%	S-1312A19-M5T1U3	S-1312A19-A4T2U3	S-1312A19-A4T1U3
2.0 V ± 1.0%	S-1312A20-M5T1U3	S-1312A20-A4T2U3	S-1312A20-A4T1U3
2.1 V ± 1.0%	S-1312A21-M5T1U3	S-1312A21-A4T2U3	S-1312A21-A4T1U3
2.2 V ± 1.0%	S-1312A22-M5T1U3	S-1312A22-A4T2U3	S-1312A22-A4T1U3
2.3 V ± 1.0%	S-1312A23-M5T1U3	S-1312A23-A4T2U3	S-1312A23-A4T1U3
2.4 V ± 1.0%	S-1312A24-M5T1U3	S-1312A24-A4T2U3	S-1312A24-A4T1U3
2.5 V ± 1.0%	S-1312A25-M5T1U3	S-1312A25-A4T2U3	S-1312A25-A4T1U3
2.6 V ± 1.0%	S-1312A26-M5T1U3	S-1312A26-A4T2U3	S-1312A26-A4T1U3
2.7 V ± 1.0%	S-1312A27-M5T1U3	S-1312A27-A4T2U3	S-1312A27-A4T1U3
2.8 V ± 1.0%	S-1312A28-M5T1U3	S-1312A28-A4T2U3	S-1312A28-A4T1U3
2.85 V ± 1.0%	S-1312A2J-M5T1U3	S-1312A2J-A4T2U3	S-1312A2J-A4T1U3
2.9 V ± 1.0%	S-1312A29-M5T1U3	S-1312A29-A4T2U3	S-1312A29-A4T1U3
3.0 V ± 1.0%	S-1312A30-M5T1U3	S-1312A30-A4T2U3	S-1312A30-A4T1U3
3.1 V ± 1.0%	S-1312A31-M5T1U3	S-1312A31-A4T2U3	S-1312A31-A4T1U3
3.2 V ± 1.0%	S-1312A32-M5T1U3	S-1312A32-A4T2U3	S-1312A32-A4T1U3
3.3 V ± 1.0%	S-1312A33-M5T1U3	S-1312A33-A4T2U3	S-1312A33-A4T1U3
3.4 V ± 1.0%	S-1312A34-M5T1U3	S-1312A34-A4T2U3	S-1312A34-A4T1U3
3.5 V ± 1.0%	S-1312A35-M5T1U3	S-1312A35-A4T2U3	S-1312A35-A4T1U3

**Remark** Please contact our sales office for products with specifications other than the above.

**4.2 S-1312 Series B type**

ON / OFF logic: Active "H"  
 Discharge shunt function: Available                      Pull-down resistor: Unavailable

**Table 4**

Output Voltage	SOT-23-5	HSNT-4 (1010)	HSNT-4 (0808)
1.0 V ± 15 mV	S-1312B10-M5T1U3	S-1312B10-A4T2U3	S-1312B10-A4T1U3
1.1 V ± 15 mV	S-1312B11-M5T1U3	S-1312B11-A4T2U3	S-1312B11-A4T1U3
1.2 V ± 15 mV	S-1312B12-M5T1U3	S-1312B12-A4T2U3	S-1312B12-A4T1U3
1.3 V ± 15 mV	S-1312B13-M5T1U3	S-1312B13-A4T2U3	S-1312B13-A4T1U3
1.4 V ± 15 mV	S-1312B14-M5T1U3	S-1312B14-A4T2U3	S-1312B14-A4T1U3
1.5 V ± 1.0%	S-1312B15-M5T1U3	S-1312B15-A4T2U3	S-1312B15-A4T1U3
1.6 V ± 1.0%	S-1312B16-M5T1U3	S-1312B16-A4T2U3	S-1312B16-A4T1U3
1.7 V ± 1.0%	S-1312B17-M5T1U3	S-1312B17-A4T2U3	S-1312B17-A4T1U3
1.8 V ± 1.0%	S-1312B18-M5T1U3	S-1312B18-A4T2U3	S-1312B18-A4T1U3
1.85 V ± 1.0%	S-1312B1J-M5T1U3	S-1312B1J-A4T2U3	S-1312B1J-A4T1U3
1.9 V ± 1.0%	S-1312B19-M5T1U3	S-1312B19-A4T2U3	S-1312B19-A4T1U3
2.0 V ± 1.0%	S-1312B20-M5T1U3	S-1312B20-A4T2U3	S-1312B20-A4T1U3
2.1 V ± 1.0%	S-1312B21-M5T1U3	S-1312B21-A4T2U3	S-1312B21-A4T1U3
2.2 V ± 1.0%	S-1312B22-M5T1U3	S-1312B22-A4T2U3	S-1312B22-A4T1U3
2.3 V ± 1.0%	S-1312B23-M5T1U3	S-1312B23-A4T2U3	S-1312B23-A4T1U3
2.4 V ± 1.0%	S-1312B24-M5T1U3	S-1312B24-A4T2U3	S-1312B24-A4T1U3
2.5 V ± 1.0%	S-1312B25-M5T1U3	S-1312B25-A4T2U3	S-1312B25-A4T1U3
2.6 V ± 1.0%	S-1312B26-M5T1U3	S-1312B26-A4T2U3	S-1312B26-A4T1U3
2.7 V ± 1.0%	S-1312B27-M5T1U3	S-1312B27-A4T2U3	S-1312B27-A4T1U3
2.8 V ± 1.0%	S-1312B28-M5T1U3	S-1312B28-A4T2U3	S-1312B28-A4T1U3
2.85 V ± 1.0%	S-1312B2J-M5T1U3	S-1312B2J-A4T2U3	S-1312B2J-A4T1U3
2.9 V ± 1.0%	S-1312B29-M5T1U3	S-1312B29-A4T2U3	S-1312B29-A4T1U3
3.0 V ± 1.0%	S-1312B30-M5T1U3	S-1312B30-A4T2U3	S-1312B30-A4T1U3
3.1 V ± 1.0%	S-1312B31-M5T1U3	S-1312B31-A4T2U3	S-1312B31-A4T1U3
3.2 V ± 1.0%	S-1312B32-M5T1U3	S-1312B32-A4T2U3	S-1312B32-A4T1U3
3.3 V ± 1.0%	S-1312B33-M5T1U3	S-1312B33-A4T2U3	S-1312B33-A4T1U3
3.4 V ± 1.0%	S-1312B34-M5T1U3	S-1312B34-A4T2U3	S-1312B34-A4T1U3
3.5 V ± 1.0%	S-1312B35-M5T1U3	S-1312B35-A4T2U3	S-1312B35-A4T1U3

**Remark** Please contact our sales office for products with specifications other than the above.

4.3 S-1312 Series C type

ON / OFF logic: Active "H"  
 Discharge shunt function: Unavailable Pull-down resistor: Available

Table 5

Output Voltage	SOT-23-5	HSNT-4 (1010)	HSNT-4 (0808)
1.0 V ± 15 mV	S-1312C10-M5T1U3	S-1312C10-A4T2U3	S-1312C10-A4T1U3
1.1 V ± 15 mV	S-1312C11-M5T1U3	S-1312C11-A4T2U3	S-1312C11-A4T1U3
1.2 V ± 15 mV	S-1312C12-M5T1U3	S-1312C12-A4T2U3	S-1312C12-A4T1U3
1.3 V ± 15 mV	S-1312C13-M5T1U3	S-1312C13-A4T2U3	S-1312C13-A4T1U3
1.4 V ± 15 mV	S-1312C14-M5T1U3	S-1312C14-A4T2U3	S-1312C14-A4T1U3
1.5 V ± 1.0%	S-1312C15-M5T1U3	S-1312C15-A4T2U3	S-1312C15-A4T1U3
1.6 V ± 1.0%	S-1312C16-M5T1U3	S-1312C16-A4T2U3	S-1312C16-A4T1U3
1.7 V ± 1.0%	S-1312C17-M5T1U3	S-1312C17-A4T2U3	S-1312C17-A4T1U3
1.8 V ± 1.0%	S-1312C18-M5T1U3	S-1312C18-A4T2U3	S-1312C18-A4T1U3
1.85 V ± 1.0%	S-1312C1J-M5T1U3	S-1312C1J-A4T2U3	S-1312C1J-A4T1U3
1.9 V ± 1.0%	S-1312C19-M5T1U3	S-1312C19-A4T2U3	S-1312C19-A4T1U3
2.0 V ± 1.0%	S-1312C20-M5T1U3	S-1312C20-A4T2U3	S-1312C20-A4T1U3
2.1 V ± 1.0%	S-1312C21-M5T1U3	S-1312C21-A4T2U3	S-1312C21-A4T1U3
2.2 V ± 1.0%	S-1312C22-M5T1U3	S-1312C22-A4T2U3	S-1312C22-A4T1U3
2.3 V ± 1.0%	S-1312C23-M5T1U3	S-1312C23-A4T2U3	S-1312C23-A4T1U3
2.4 V ± 1.0%	S-1312C24-M5T1U3	S-1312C24-A4T2U3	S-1312C24-A4T1U3
2.5 V ± 1.0%	S-1312C25-M5T1U3	S-1312C25-A4T2U3	S-1312C25-A4T1U3
2.6 V ± 1.0%	S-1312C26-M5T1U3	S-1312C26-A4T2U3	S-1312C26-A4T1U3
2.7 V ± 1.0%	S-1312C27-M5T1U3	S-1312C27-A4T2U3	S-1312C27-A4T1U3
2.8 V ± 1.0%	S-1312C28-M5T1U3	S-1312C28-A4T2U3	S-1312C28-A4T1U3
2.85 V ± 1.0%	S-1312C2J-M5T1U3	S-1312C2J-A4T2U3	S-1312C2J-A4T1U3
2.9 V ± 1.0%	S-1312C29-M5T1U3	S-1312C29-A4T2U3	S-1312C29-A4T1U3
3.0 V ± 1.0%	S-1312C30-M5T1U3	S-1312C30-A4T2U3	S-1312C30-A4T1U3
3.1 V ± 1.0%	S-1312C31-M5T1U3	S-1312C31-A4T2U3	S-1312C31-A4T1U3
3.2 V ± 1.0%	S-1312C32-M5T1U3	S-1312C32-A4T2U3	S-1312C32-A4T1U3
3.3 V ± 1.0%	S-1312C33-M5T1U3	S-1312C33-A4T2U3	S-1312C33-A4T1U3
3.4 V ± 1.0%	S-1312C34-M5T1U3	S-1312C34-A4T2U3	S-1312C34-A4T1U3
3.5 V ± 1.0%	S-1312C35-M5T1U3	S-1312C35-A4T2U3	S-1312C35-A4T1U3

**Remark** Please contact our sales office for products with specifications other than the above.

**4.4 S-1312 Series D type**

ON / OFF logic: Active "H"  
 Discharge shunt function: Unavailable Pull-down resistor: Unavailable

**Table 6**

Output Voltage	SOT-23-5	HSNT-4 (1010)	HSNT-4 (0808)
1.0 V ± 15 mV	S-1312D10-M5T1U3	S-1312D10-A4T2U3	S-1312D10-A4T1U3
1.1 V ± 15 mV	S-1312D11-M5T1U3	S-1312D11-A4T2U3	S-1312D11-A4T1U3
1.2 V ± 15 mV	S-1312D12-M5T1U3	S-1312D12-A4T2U3	S-1312D12-A4T1U3
1.3 V ± 15 mV	S-1312D13-M5T1U3	S-1312D13-A4T2U3	S-1312D13-A4T1U3
1.4 V ± 15 mV	S-1312D14-M5T1U3	S-1312D14-A4T2U3	S-1312D14-A4T1U3
1.5 V ± 1.0%	S-1312D15-M5T1U3	S-1312D15-A4T2U3	S-1312D15-A4T1U3
1.6 V ± 1.0%	S-1312D16-M5T1U3	S-1312D16-A4T2U3	S-1312D16-A4T1U3
1.7 V ± 1.0%	S-1312D17-M5T1U3	S-1312D17-A4T2U3	S-1312D17-A4T1U3
1.8 V ± 1.0%	S-1312D18-M5T1U3	S-1312D18-A4T2U3	S-1312D18-A4T1U3
1.85 V ± 1.0%	S-1312D1J-M5T1U3	S-1312D1J-A4T2U3	S-1312D1J-A4T1U3
1.9 V ± 1.0%	S-1312D19-M5T1U3	S-1312D19-A4T2U3	S-1312D19-A4T1U3
2.0 V ± 1.0%	S-1312D20-M5T1U3	S-1312D20-A4T2U3	S-1312D20-A4T1U3
2.1 V ± 1.0%	S-1312D21-M5T1U3	S-1312D21-A4T2U3	S-1312D21-A4T1U3
2.2 V ± 1.0%	S-1312D22-M5T1U3	S-1312D22-A4T2U3	S-1312D22-A4T1U3
2.3 V ± 1.0%	S-1312D23-M5T1U3	S-1312D23-A4T2U3	S-1312D23-A4T1U3
2.4 V ± 1.0%	S-1312D24-M5T1U3	S-1312D24-A4T2U3	S-1312D24-A4T1U3
2.5 V ± 1.0%	S-1312D25-M5T1U3	S-1312D25-A4T2U3	S-1312D25-A4T1U3
2.6 V ± 1.0%	S-1312D26-M5T1U3	S-1312D26-A4T2U3	S-1312D26-A4T1U3
2.7 V ± 1.0%	S-1312D27-M5T1U3	S-1312D27-A4T2U3	S-1312D27-A4T1U3
2.8 V ± 1.0%	S-1312D28-M5T1U3	S-1312D28-A4T2U3	S-1312D28-A4T1U3
2.85 V ± 1.0%	S-1312D2J-M5T1U3	S-1312D2J-A4T2U3	S-1312D2J-A4T1U3
2.9 V ± 1.0%	S-1312D29-M5T1U3	S-1312D29-A4T2U3	S-1312D29-A4T1U3
3.0 V ± 1.0%	S-1312D30-M5T1U3	S-1312D30-A4T2U3	S-1312D30-A4T1U3
3.1 V ± 1.0%	S-1312D31-M5T1U3	S-1312D31-A4T2U3	S-1312D31-A4T1U3
3.2 V ± 1.0%	S-1312D32-M5T1U3	S-1312D32-A4T2U3	S-1312D32-A4T1U3
3.3 V ± 1.0%	S-1312D33-M5T1U3	S-1312D33-A4T2U3	S-1312D33-A4T1U3
3.4 V ± 1.0%	S-1312D34-M5T1U3	S-1312D34-A4T2U3	S-1312D34-A4T1U3
3.5 V ± 1.0%	S-1312D35-M5T1U3	S-1312D35-A4T2U3	S-1312D35-A4T1U3

**Remark** Please contact our sales office for products with specifications other than the above.



■ Pin Configurations

1. SOT-23-5

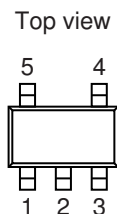

Figure 5

**Table 7**

Pin No.	Symbol	Description
1	VIN	Input voltage pin
2	VSS	GND pin
3	ON / OFF	ON / OFF pin
4	NC*1	No connection
5	VOUT	Output voltage pin

\*1. The NC pin is electrically open.  
The NC pin can be connected to the VIN pin or the VSS pin.

2. HSNT-4 (1010)

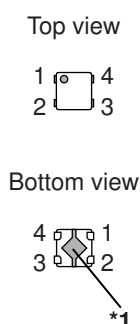

Figure 6

**Table 8**

Pin No.	Symbol	Description
1	VOUT	Output voltage pin
2	VSS	GND pin
3	ON / OFF	ON / OFF pin
4	VIN	Input voltage pin

\*1. Connect the heatsink of backside at shadowed area to the board, and set electric potential open or GND. However, do not use it as the function of electrode.

3. HSNT-4 (0808)

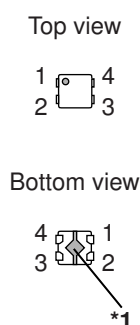

Figure 7

**Table 9**

Pin No.	Symbol	Description
1	VOUT	Output voltage pin
2	VSS	GND pin
3	ON / OFF	ON / OFF pin
4	VIN	Input voltage pin

\*1. Connect the heatsink of backside at shadowed area to the board, and set electric potential open or GND. However, do not use it as the function of electrode.

■ Absolute Maximum Ratings

Table 10

(Ta = +25°C unless otherwise specified)

Item	Symbol	Absolute Maximum Rating	Unit	
Input voltage	V <sub>IN</sub>	V <sub>SS</sub> - 0.3 to V <sub>SS</sub> + 6.0	V	
	V <sub>ON/OFF</sub>	V <sub>SS</sub> - 0.3 to V <sub>SS</sub> + 6.0	V	
Output voltage	V <sub>OUT</sub>	V <sub>SS</sub> - 0.3 to V <sub>IN</sub> + 0.3	V	
Output current	I <sub>OUT</sub>	180	mA	
Power dissipation	P <sub>D</sub>	SOT-23-5	600 <sup>*1</sup>	mW
		HSNT-4 (1010)	340 <sup>*1</sup>	mW
		HSNT-4 (0808)	335 <sup>*1</sup>	mW
Operation ambient temperature	T <sub>opr</sub>	-40 to +85	°C	
Storage temperature	T <sub>stg</sub>	-40 to +125	°C	

\*1. When mounted on board  
[Mounted board]

- (1) Board size: 114.3 mm × 76.2 mm × t1.6 mm
- (2) Name: JEDEC STANDARD51-7

**Caution** The absolute maximum ratings are rated values exceeding which the product could suffer physical damage. These values must therefore not be exceeded under any conditions.

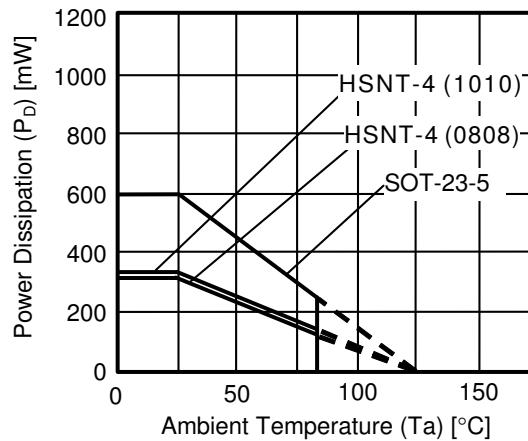

Figure 8 Power Dissipation of Package (When Mounted on Board)

**Power Dissipation of HSNT-4 (1010) and HSNT-4 (0808) (Reference)**

Power dissipation of package differs depending on the mounting conditions.

Consider the power dissipation characteristics under the following conditions as reference.

[Mounted board]

- (1) Board size: 40 mm × 40 mm × t0.8 mm
- (2) Board material: Glass epoxy resin (four layers)
- (3) Wiring ratio: 50%
- (4) Test conditions: When mounted on board (wind speed: 0 m/s)
- (5) Land pattern: Refer to the recommended land pattern

Drawing code: PL004-A-L-SD (HSNT-4 (1010)), PK004-A-L-SD (HSNT-4 (0808))

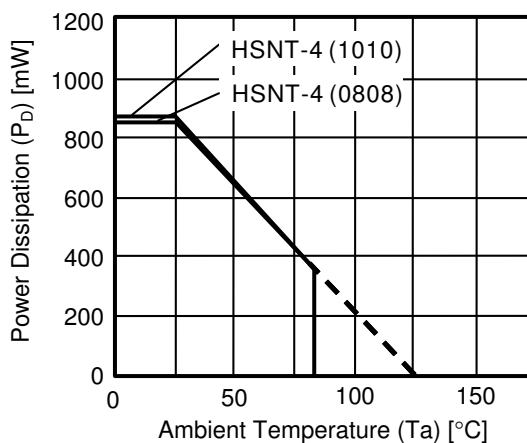

**Figure 9 Power Dissipation of Package (When Mounted on Board)**

**Table 11**

Condition	Power Dissipation (Reference)	Thermal Resistance Value ( $\theta$ )-a)
HSNT-4 (1010) (When mounted on board)	870 mW	115°C/W
HSNT-4 (0808) (When mounted on board)	850 mW	117°C/W

■ Electrical Characteristics

Table 12

(Ta = +25°C unless otherwise specified)

Item	Symbol	Condition	Min.	Typ.	Max.	Unit	Test Circuit	
Output voltage <sup>1</sup>	V <sub>OUT(E)</sub>	V <sub>IN</sub> = V <sub>OUT(S)</sub> + 1.0 V, I <sub>OUT</sub> = 30 mA	1.0 V ≤ V <sub>OUT(S)</sub> < 1.5 V	V <sub>OUT(S)</sub> − 0.015	V <sub>OUT(S)</sub>	V <sub>OUT(S)</sub> + 0.015	V	1
			1.5 V ≤ V <sub>OUT(S)</sub> ≤ 3.5 V	V <sub>OUT(S)</sub> × 0.99	V <sub>OUT(S)</sub>	V <sub>OUT(S)</sub> × 1.01	V	1
Output current <sup>2</sup>	I <sub>OUT</sub>	V <sub>IN</sub> ≥ V <sub>OUT(S)</sub> + 1.0 V	150 <sup>5</sup>	–	–	mA	3	
Dropout voltage <sup>3</sup>	V <sub>drop</sub>	I <sub>OUT</sub> = 100 mA	1.0 V ≤ V <sub>OUT(S)</sub> < 1.1 V	0.50	0.68	0.86	V	1
			1.1 V ≤ V <sub>OUT(S)</sub> < 1.2 V	–	0.52	0.71	V	1
			1.2 V ≤ V <sub>OUT(S)</sub> < 1.3 V	–	0.31	0.63	V	1
			1.3 V ≤ V <sub>OUT(S)</sub> < 1.4 V	–	0.28	0.56	V	1
			1.4 V ≤ V <sub>OUT(S)</sub> < 1.5 V	–	0.26	0.50	V	1
			1.5 V ≤ V <sub>OUT(S)</sub> < 1.7 V	–	0.24	0.47	V	1
			1.7 V ≤ V <sub>OUT(S)</sub> < 2.0 V	–	0.22	0.43	V	1
			2.0 V ≤ V <sub>OUT(S)</sub> < 2.5 V	–	0.18	0.36	V	1
			2.5 V ≤ V <sub>OUT(S)</sub> < 3.0 V	–	0.16	0.32	V	1
			3.0 V ≤ V <sub>OUT(S)</sub> < 3.3 V	–	0.15	0.28	V	1
3.3 V ≤ V <sub>OUT(S)</sub> ≤ 3.5 V	–	0.14	0.27	V	1			
Line regulation	ΔV <sub>OUT1</sub>	1.0 V ≤ V <sub>OUT(S)</sub> < 1.1 V 1.6 V ≤ V <sub>IN</sub> ≤ 5.5 V, I <sub>OUT</sub> = 30 mA	–	0.02	0.1	%/V	1	
	ΔV <sub>IN</sub> • V <sub>OUT</sub>	1.1 V ≤ V <sub>OUT(S)</sub> ≤ 3.5 V V <sub>OUT(S)</sub> + 0.5 V ≤ V <sub>IN</sub> ≤ 5.5 V, I <sub>OUT</sub> = 30 mA	–	0.02	0.1	%/V	1	
Load regulation	ΔV <sub>OUT2</sub>	V <sub>IN</sub> = V <sub>OUT(S)</sub> + 1.0 V, 100 μA ≤ I <sub>OUT</sub> ≤ 100 mA	–	20	40	mV	1	
Output voltage temperature coefficient <sup>4</sup>	ΔV <sub>OUT</sub> ΔTa • V <sub>OUT</sub>	V <sub>IN</sub> = V <sub>OUT(S)</sub> + 1.0 V, I <sub>OUT</sub> = 30 mA, −40°C ≤ Ta ≤ +85°C	–	±130	–	ppm/°C	1	
Current consumption during operation	I <sub>SS1</sub>	V <sub>IN</sub> = V <sub>OUT(S)</sub> + 1.0 V, ON / OFF pin = ON, no load	–	20	30	μA	2	
Current consumption during power-off	I <sub>SS2</sub>	V <sub>IN</sub> = V <sub>OUT(S)</sub> + 1.0 V, ON / OFF pin = OFF, no load	–	0.1	1.0	μA	2	
Input voltage	V <sub>IN</sub>	–	1.5	–	5.5	V	–	
ON / OFF pin input voltage "H"	V <sub>SH</sub>	V <sub>IN</sub> = V <sub>OUT(S)</sub> + 1.0 V, R <sub>L</sub> = 1.0 kΩ determined by V <sub>OUT</sub> output level	1.0	–	–	V	4	
ON / OFF pin input voltage "L"	V <sub>SL</sub>	V <sub>IN</sub> = V <sub>OUT(S)</sub> + 1.0 V, R <sub>L</sub> = 1.0 kΩ determined by V <sub>OUT</sub> output level	–	–	0.25	V	4	
ON / OFF pin input current "H"	I <sub>SH</sub>	V <sub>IN</sub> = 5.5 V, V <sub>ON / OFF</sub> = 5.5 V	B / D type (without pull-down resistor)	−0.1	–	0.1	μA	4
			A / C type (with pull-down resistor)	1.0	2.5	5.0	μA	4
ON / OFF pin input current "L"	I <sub>SL</sub>	V <sub>IN</sub> = 5.5 V, V <sub>ON / OFF</sub> = 0 V	−0.1	–	0.1	μA	4	
Ripple rejection	RR	V <sub>IN</sub> = V <sub>OUT(S)</sub> + 1.0 V, f = 1.0 kHz, ΔV <sub>rip</sub> = 0.5 Vrms, I <sub>OUT</sub> = 30 mA	1.0 V ≤ V <sub>OUT(S)</sub> ≤ 1.2 V	–	75	–	dB	5
			1.2 V < V <sub>OUT(S)</sub> ≤ 2.85 V	–	70	–	dB	5
			2.85 V < V <sub>OUT(S)</sub> ≤ 3.5 V	–	65	–	dB	5
Short-circuit current	I <sub>short</sub>	V <sub>IN</sub> = V <sub>OUT(S)</sub> + 1.0 V, ON / OFF pin = ON, V <sub>OUT</sub> = 0 V	–	50	–	mA	3	
Thermal shutdown detection temperature	T <sub>SD</sub>	Junction temperature	–	150	–	°C	–	
Thermal shutdown release temperature	T <sub>SR</sub>	Junction temperature	–	120	–	°C	–	
"L" output Nch ON resistance	R <sub>LOW</sub>	V <sub>OUT</sub> = 0.1 V, V <sub>IN</sub> = 5.5 V	–	35	–	Ω	3	
Power-off pull-down resistor	R <sub>PD</sub>	–	1.0	2.2	5.0	MΩ	4	

- \*1.  $V_{OUT(S)}$ : Set output voltage  
 $V_{OUT(E)}$ : Actual output voltage  
 Output voltage when fixing  $I_{OUT}$  (= 30 mA) and inputting  $V_{OUT(S)} + 1.0$  V
- \*2. The output current at which the output voltage becomes 95% of  $V_{OUT(E)}$  after gradually increasing the output current.
- \*3.  $V_{drop} = V_{IN1} - (V_{OUT3} \times 0.98)$   
 $V_{OUT3}$  is the output voltage when  $V_{IN} = V_{OUT(S)} + 1.0$  V and  $I_{OUT} = 100$  mA.  
 $V_{IN1}$  is the input voltage at which the output voltage becomes 98% of  $V_{OUT3}$  after gradually decreasing the input voltage.
- \*4. A change in the temperature of the output voltage [mV/°C] is calculated using the following equation.  

$$\frac{\Delta V_{OUT}}{\Delta T_a} \text{ [mV/°C]}^{*1} = V_{OUT(S)} \text{ [V]}^{*2} \times \frac{\Delta V_{OUT}}{\Delta T_a \bullet V_{OUT}} \text{ [ppm/°C]}^{*3} \div 1000$$
  - \*1. Change in temperature of output voltage
  - \*2. Set output voltage
  - \*3. Output voltage temperature coefficient
- \*5. The output current can be at least this value.  
 Due to restrictions on the package power dissipation, this value may not be satisfied. Attention should be paid to the power dissipation of the package when the output current is large.  
 This specification is guaranteed by design.

■ Test Circuits

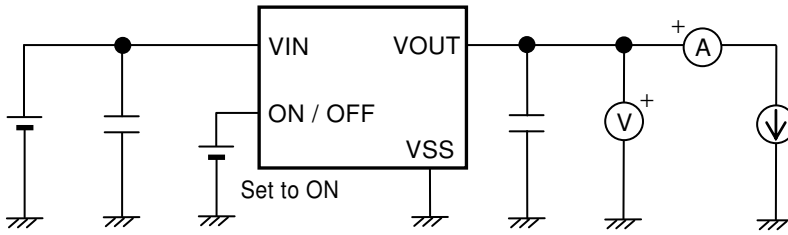

Figure 10 Test Circuit 1

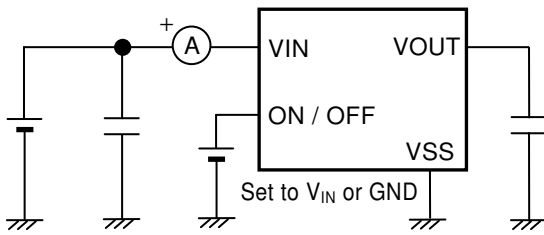

Figure 11 Test Circuit 2

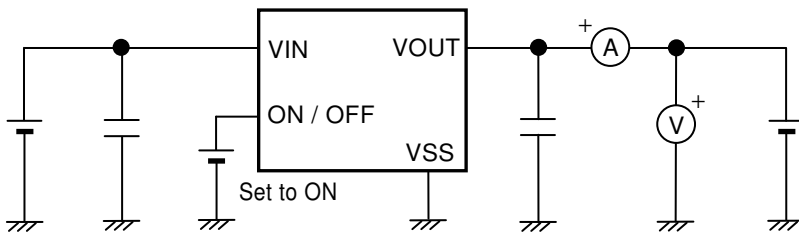

Figure 12 Test Circuit 3

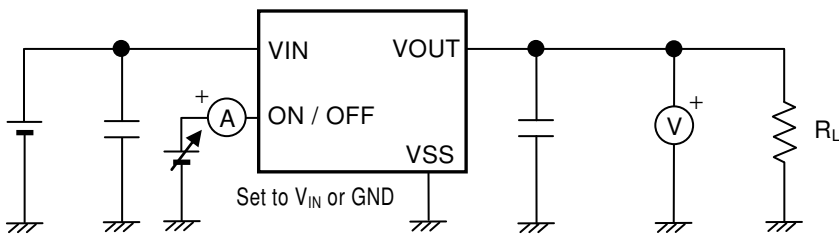

Figure 13 Test Circuit 4

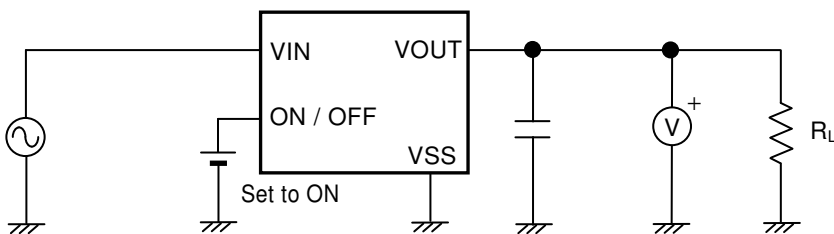
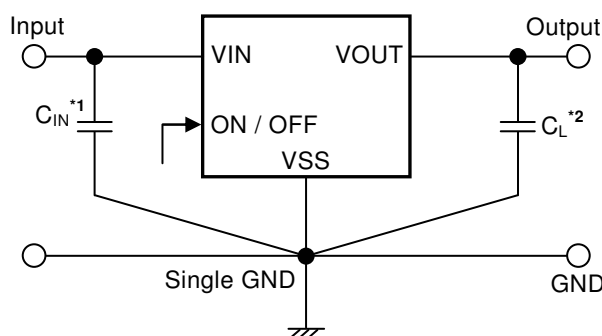

Figure 14 Test Circuit 5

■ Standard Circuit



- \*1.  $C_{IN}$  is a capacitor for stabilizing the input.
- \*2. A ceramic capacitor of 0.22  $\mu\text{F}$  or more can be used as  $C_L$ .

Figure 15

**Caution** The above connection diagram and constant will not guarantee successful operation. Perform thorough evaluation using the actual application to set the constant.

■ Condition of Application

Input capacitor ( $C_{IN}$ ): 0.22  $\mu\text{F}$  or more  
 Output capacitor ( $C_L$ ): 0.22  $\mu\text{F}$  or more

**Caution** Generally a series regulator may cause oscillation, depending on the selection of external parts. Confirm that no oscillation occurs in the application for which the above capacitors are used.

■ Selection of Input and Output Capacitors ( $C_{IN}$ ,  $C_L$ )

The S-1312 Series requires an output capacitor between the VOUT pin and the VSS pin for phase compensation. Operation is stabilized by a ceramic capacitor with an output capacitance of 0.22  $\mu\text{F}$  or more over the entire temperature range. When using an OS capacitor, a tantalum capacitor, or an aluminum electrolytic capacitor, the capacitance must be 0.22  $\mu\text{F}$  or more.

The value of the output overshoot or undershoot transient response varies depending on the value of the output capacitor. The required capacitance of the input capacitor differs depending on the application.

The recommended capacitance for an application is  $C_{IN} \geq 0.22 \mu\text{F}$ ,  $C_L \geq 0.22 \mu\text{F}$ ; however, when selecting the output capacitor, perform sufficient evaluation, including evaluation of temperature characteristics, on the actual device.

## ■ Explanation of Terms

### 1. Low dropout voltage regulator

This voltage regulator has the low dropout voltage due to its built-in low on-resistance transistor.

### 2. Output voltage ( $V_{OUT}$ )

The accuracy of the output voltage is ensured at  $\pm 1.0\%$  or  $\pm 15 \text{ mV}^*1$  under the specified conditions of fixed input voltage<sup>\*2</sup>, fixed output current, and fixed temperature.

\*1. When  $V_{OUT} < 1.5 \text{ V}$ :  $\pm 15 \text{ mV}$ , when  $V_{OUT} \geq 1.5 \text{ V}$ :  $\pm 1.0\%$

\*2. Differs depending on the product.

**Caution** If the above conditions change, the output voltage value may vary and exceed the accuracy range of the output voltage. Refer to "■ Electrical Characteristics" and "■ Characteristics (Typical Data)" for details.

### 3. Line regulation $\left( \frac{\Delta V_{OUT1}}{\Delta V_{IN} \bullet V_{OUT}} \right)$

Indicates the dependency of the output voltage on the input voltage. That is, the values show how much the output voltage changes due to a change in the input voltage with the output current remaining unchanged.

### 4. Load regulation ( $\Delta V_{OUT2}$ )

Indicates the dependency of the output voltage on the output current. That is, the values show how much the output voltage changes due to a change in the output current with the input voltage remaining unchanged.

### 5. Dropout voltage ( $V_{drop}$ )

Indicates the difference between input voltage  $V_{IN1}$  and the output voltage when; decreasing input voltage  $V_{IN}$  gradually until the output voltage has dropped out to the value of 98% of output voltage  $V_{OUT3}$ , which is at  $V_{IN} = V_{OUT(S)} + 1.0 \text{ V}$ .

$$V_{drop} = V_{IN1} - (V_{OUT3} \times 0.98)$$



6. Output voltage temperature coefficient  $\left(\frac{\Delta V_{OUT}}{\Delta T_a \bullet V_{OUT}}\right)$

The shaded area in **Figure 16** is the range where  $V_{OUT}$  varies in the operation temperature range when the output voltage temperature coefficient is  $\pm 130$  ppm/ $^{\circ}$ C.

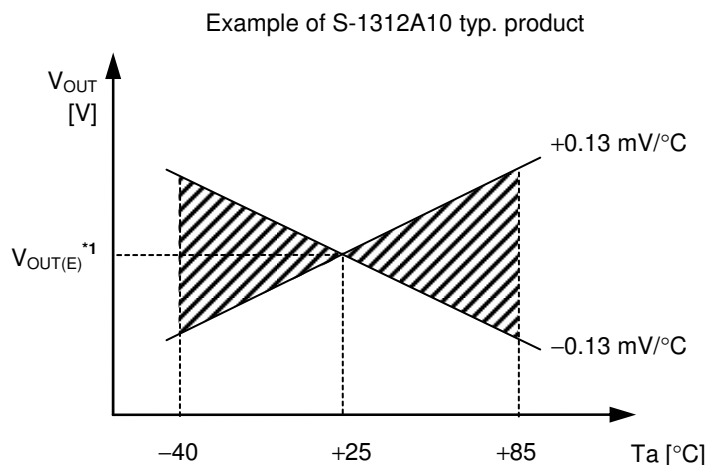

\*1.  $V_{OUT(E)}$  is the value of the output voltage measured at  $T_a = +25^{\circ}$ C.

**Figure 16**

A change in the temperature of the output voltage [mV/ $^{\circ}$ C] is calculated using the following equation.

$$\frac{\Delta V_{OUT}}{\Delta T_a} \text{ [mV/}^{\circ}\text{C]}^{*1} = V_{OUT(S)} \text{ [V]}^{*2} \times \frac{\Delta V_{OUT}}{\Delta T_a \bullet V_{OUT}} \text{ [ppm/}^{\circ}\text{C]}^{*3} \div 1000$$

- \*1. Change in temperature of output voltage
- \*2. Set output voltage
- \*3. Output voltage temperature coefficient

■ **Operation**

**1. Basic operation**

**Figure 17** shows the block diagram of the S-1312 Series.

The error amplifier compares the reference voltage ( $V_{ref}$ ) with feedback voltage ( $V_{fb}$ ), which is the output voltage resistance-divided by feedback resistors ( $R_s$  and  $R_f$ ). It supplies the gate voltage necessary to maintain the constant output voltage which is not influenced by the input voltage and temperature change, to the output transistor.

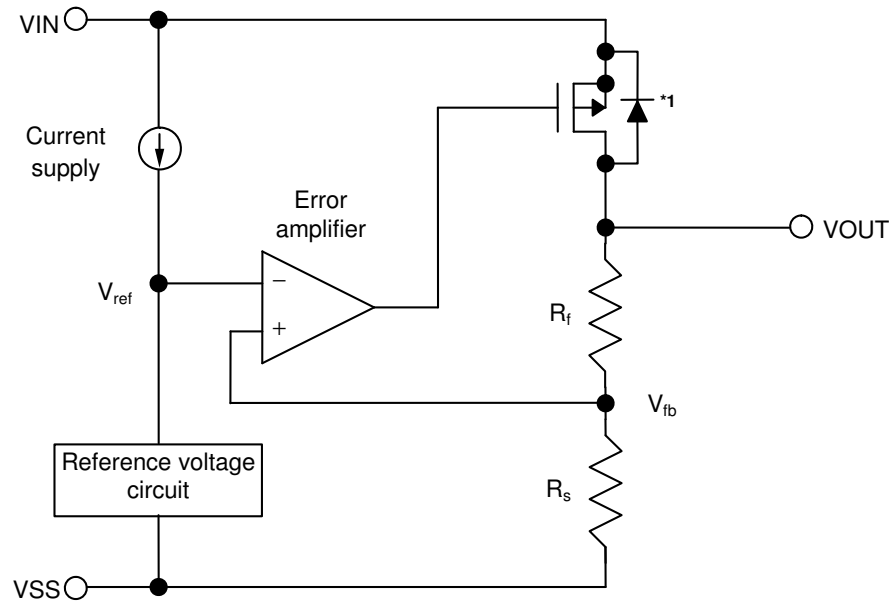

\*1. Parasitic diode

**Figure 17**

**2. Output transistor**

In the S-1312 Series, a low on-resistance P-channel MOS FET is used as the output transistor.

Be sure that  $V_{OUT}$  does not exceed  $V_{IN} + 0.3$  V to prevent the voltage regulator from being damaged due to inverse current flowing from the VOUT pin through a parasitic diode to the VIN pin.

### 3. ON / OFF pin

This pin starts and stops the regulator.

When the ON / OFF pin is set to OFF level, the entire internal circuit stops operating, and the built-in P-channel MOS FET output transistor between the VIN pin and the VOUT pin is turned off, reducing current consumption significantly.

Note that the current consumption increases when a voltage of 0.25 V to  $V_{IN} - 0.3$  V is applied to the ON / OFF pin. The ON / OFF pin is configured as shown in **Figure 18** and **Figure 19**.

#### 3.1 S-1312 Series A / C type

The ON / OFF pin is internally pulled down to the VSS pin in the floating status, so the VOUT pin is set to the  $V_{SS}$  level.

For the ON / OFF pin current, refer to the A / C type of the ON / OFF pin input current "H" in "■ **Electrical Characteristics**".

#### 3.2 S-1312 Series B / D type

The ON / OFF pin is internally not pulled up or pulled down, so do not use this pin in the floating status. When not using the ON / OFF pin, connect the pin to the VIN pin.

**Table 13**

Product Type	ON / OFF Pin	Internal Circuit	VOUT Pin Voltage	Current Consumption
A / B / C / D	"H": ON	Operate	Set value	$I_{SS1}^{*1}$
A / B / C / D	"L": OFF	Stop	$V_{SS}$ level	$I_{SS2}$

\*1. Note that the IC's current consumption increases as much as current flows into the pull-down resistor when the ON / OFF pin is connected to the VIN pin and the S-1312 Series A / C type is operating (refer to **Figure 18**).

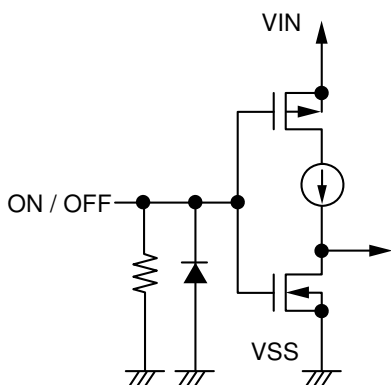

**Figure 18** S-1312 Series A / C type

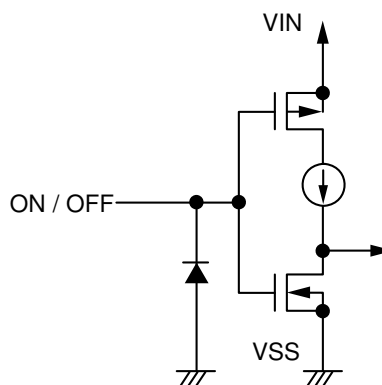

**Figure 19** S-1312 Series B / D type

**4. Discharge shunt function (S-1312 Series A / B type)**

The S-1312 Series A / B type has a built-in discharge shunt circuit to discharge the output capacitance. The output capacitance is discharged as follows so that the VOUT pin reaches the V<sub>SS</sub> level.

- (1) The ON / OFF pin is set to OFF level.
- (2) The output transistor is turned off.
- (3) The discharge shunt circuit is turned on.
- (4) The output capacitor discharges.

Since the S-1312 Series C / D type does not have a discharge shunt circuit, the VOUT pin is set to the V<sub>SS</sub> level through several hundred kΩ internal divided resistors between the VOUT pin and the VSS pin. The S-1312 Series A / B type allows the VOUT pin to reach the V<sub>SS</sub> level rapidly due to the discharge shunt circuit.

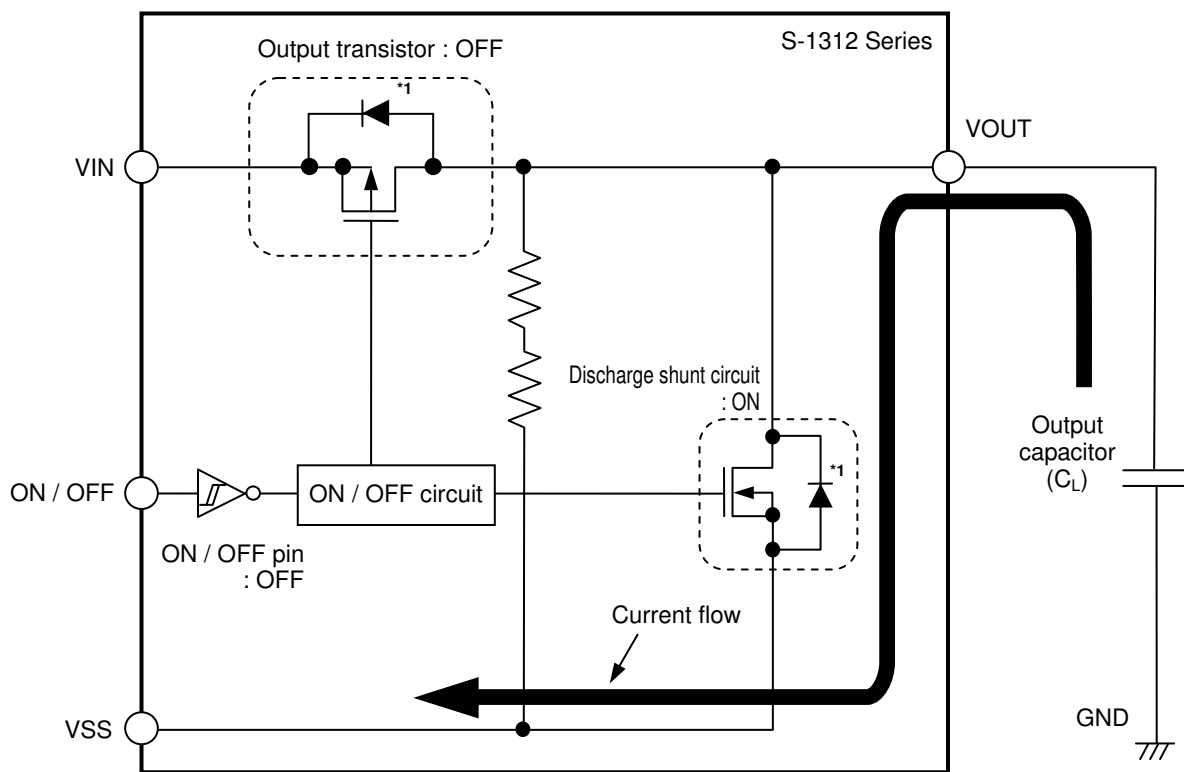

\*1. Parasitic diode

Figure 20

**5. Pull-down resistor (S-1312 Series A / C type)**

The ON / OFF pin is internally pulled down to the VSS pin in the floating status, so the VOUT pin is set to the V<sub>SS</sub> level.

Note that the IC's current consumption increases as much as current flows into the pull-down resistor of 2.2 MΩ typ. when the ON / OFF pin is connected to the VIN pin and the S-1312 Series A / C type is operating.

## 6. Overcurrent protection circuit

The S-1312 Series includes an overcurrent protection circuit having the characteristics shown in "1. **Output voltage vs. Output current (When load current increases) (Ta = +25°C)**" in "■ **Characteristics (Typical Data)**", in order to protect the output transistor against an excessive output current and short circuiting between the VOUT pin and the VSS pin. The current ( $I_{short}$ ) when the output pin is short-circuited is internally set at approx. 50 mA typ., and the normal value is restored for the output voltage, if releasing a short circuit once.

**Caution This overcurrent protection circuit does not work as for thermal protection. If this IC long keeps short circuiting inside, pay attention to the conditions of input voltage and load current so that, under the usage conditions including short circuit, the loss of the IC will not exceed power dissipation of the package.**

## 7. Thermal shutdown circuit

The S-1312 Series has a thermal shutdown circuit to protect the device from damage due to overheat. When the junction temperature rises to 150°C typ., the thermal shutdown circuit operates to stop regulating. When the junction temperature drops to 120°C typ., the thermal shutdown circuit is released to restart regulating.

Due to self-heating of the S-1312 Series, if the thermal shutdown circuit starts operating, it stops regulating so that the output voltage drops. When regulation stops, the S-1312 Series does not itself generate heat and the IC's temperature drops. When the temperature drops, the thermal shutdown circuit is released to restart regulating, thus the S-1312 Series generates heat again. Repeating this procedure makes the waveform of the output voltage into a pulse-like form. Stop or restart of regulation continues unless decreasing either or both of the input voltage and the output current in order to reduce the internal power consumption, or decreasing the ambient temperature.

**Table 14**

Thermal Shutdown Circuit	VOUT Pin Voltage
Operate: 150°C typ.*1	V <sub>SS</sub> level
Release: 120°C typ.*1	Set value

\*1. Junction temperature

## ■ Precautions

- Wiring patterns for the VIN pin, the VOUT pin and GND should be designed so that the impedance is low. When mounting an output capacitor between the VOUT pin and the VSS pin ( $C_L$ ) and a capacitor for stabilizing the input between the VIN pin and the VSS pin ( $C_{IN}$ ), the distance from the capacitors to these pins should be as short as possible.
- Note that generally the output voltage may increase when a series regulator is used at low load current (1.0 mA or less).
- Note that generally the output voltage may increase due to the leakage current from an output driver when a series regulator is used at high temperature.
- Note that the output voltage may increase due to the leakage current from an output driver even if the ON / OFF pin is at OFF level when a series regulator is used at high temperature.
- Generally a series regulator may cause oscillation, depending on the selection of external parts. The following conditions are recommended for the S-1312 Series. However, be sure to perform sufficient evaluation under the actual usage conditions for selection, including evaluation of temperature characteristics. Refer to "5. Example of equivalent series resistance vs. Output current characteristics ( $T_a = +25^\circ\text{C}$ )" in "■ Reference Data" for the equivalent series resistance ( $R_{ESR}$ ) of the output capacitor.

Input capacitor ( $C_{IN}$ ):	0.22 $\mu\text{F}$ or more
Output capacitor ( $C_L$ ):	0.22 $\mu\text{F}$ or more

- The voltage regulator may oscillate when the impedance of the power supply is high and the input capacitance is small or an input capacitor is not connected.
- If the output capacitance is small, power supply's fluctuation and the characteristics of load fluctuation become worse. Sufficiently evaluate the output voltage's fluctuation with the actual device.
- Overshoot may occur in the output voltage momentarily if the voltage is rapidly raised at power-on or when the power supply fluctuates. Sufficiently evaluate the output voltage at power-on with the actual device.
- The application conditions for the input voltage, the output voltage, and the load current should not exceed the package power dissipation.
- Do not apply an electrostatic discharge to this IC that exceeds the performance ratings of the built-in electrostatic protection circuit.
- In determining the output current, attention should be paid to the output current value specified in **Table 12** in "■ Electrical Characteristics" and footnote \*5 of the table.
- SII claims no responsibility for any disputes arising out of or in connection with any infringement by products including this IC of patents owned by a third party.

■ Characteristics (Typical Data)

1. Output voltage vs. Output current (When load current increases) ( $T_a = +25^\circ\text{C}$ )

1.1  $V_{OUT} = 1.0\text{ V}$

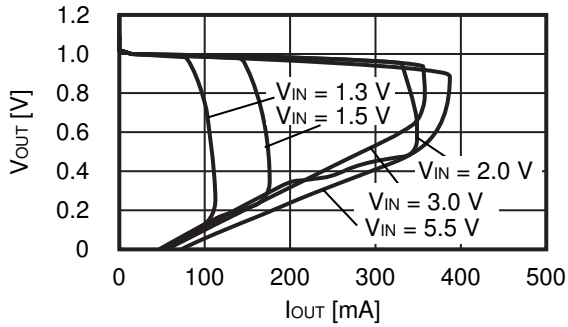

1.2  $V_{OUT} = 2.5\text{ V}$

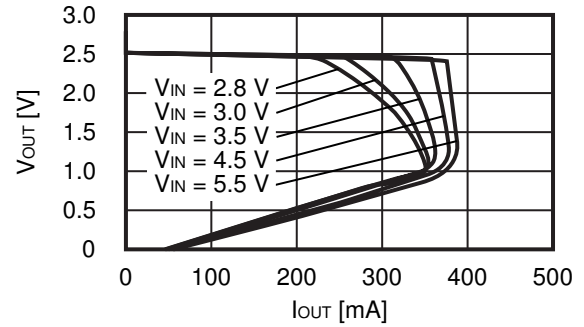

1.3  $V_{OUT} = 3.5\text{ V}$

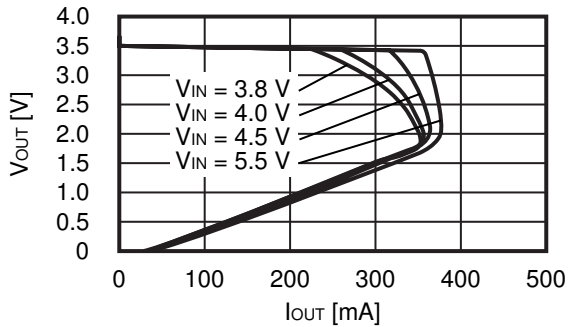

**Remark** In determining the output current, attention should be paid to the following.

1. The minimum output current value and footnote \*5 in Table 12 in "■ Electrical Characteristics"
2. The package power dissipation

2. Output voltage vs. Input voltage ( $T_a = +25^\circ\text{C}$ )

2.1  $V_{OUT} = 1.0\text{ V}$

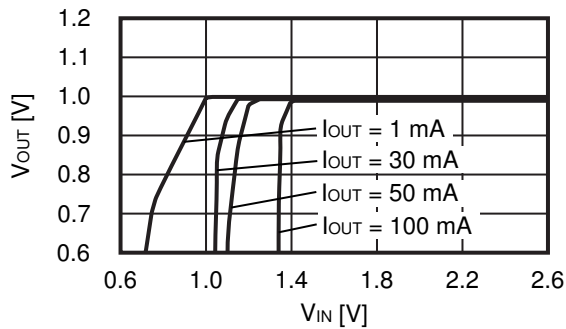

2.2  $V_{OUT} = 2.5\text{ V}$

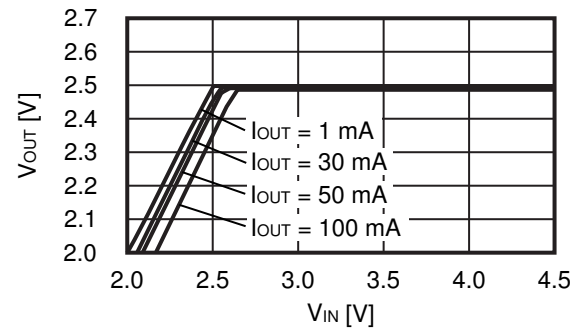

2.3  $V_{OUT} = 3.5\text{ V}$

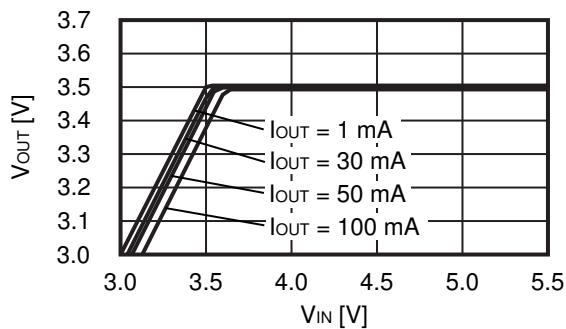

**3. Dropout voltage vs. Output current**

**3.1  $V_{OUT} = 1.0\text{ V}$**

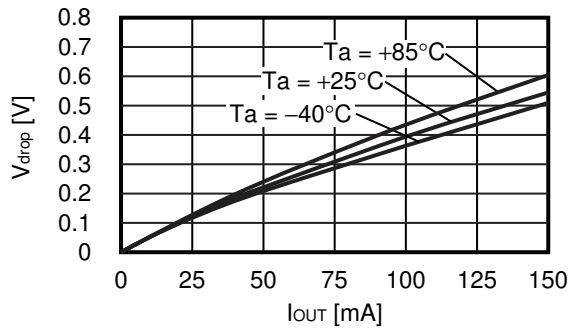

**3.2  $V_{OUT} = 2.5\text{ V}$**

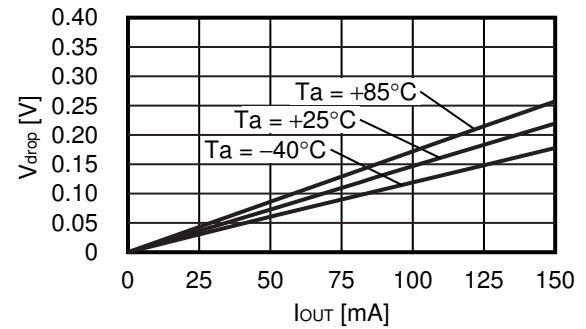

**3.3  $V_{OUT} = 3.5\text{ V}$**

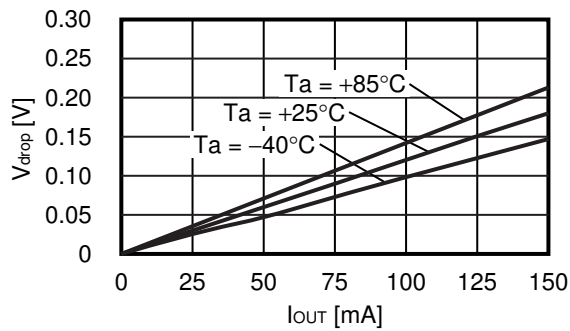

**4. Dropout voltage vs. Set output voltage**

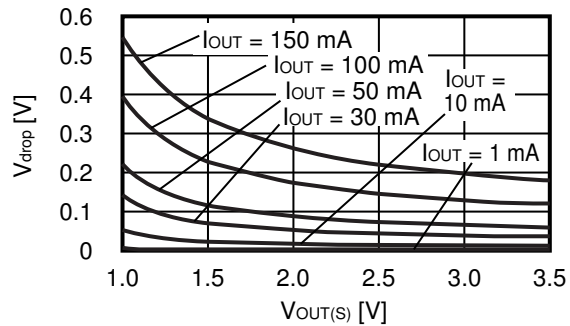



5. Output voltage vs. Ambient temperature

5.1  $V_{OUT} = 1.0\text{ V}$

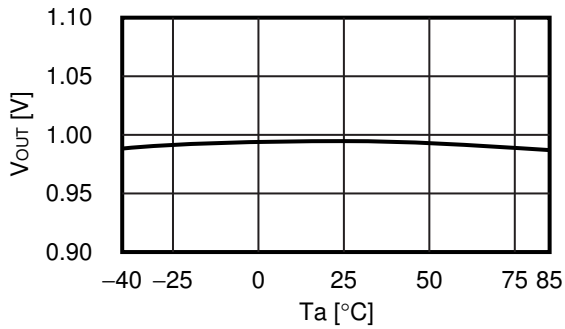

5.2  $V_{OUT} = 2.5\text{ V}$

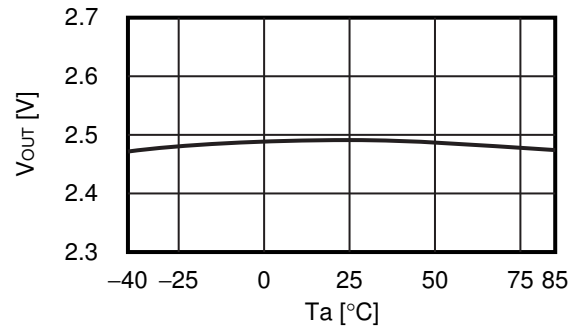

5.3  $V_{OUT} = 3.5\text{ V}$

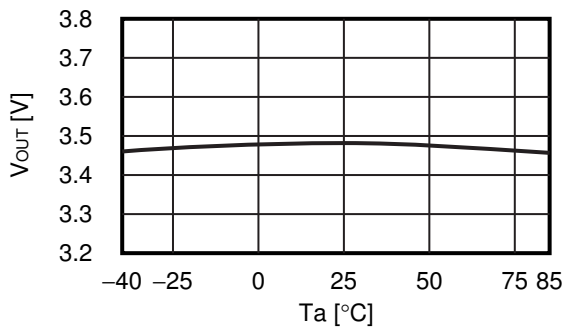

6. Current consumption vs. Input voltage

6.1  $V_{OUT} = 1.0\text{ V}$

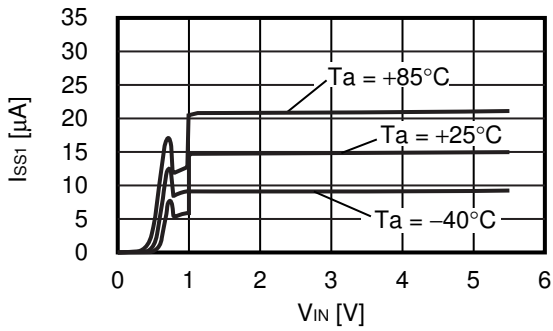

6.2  $V_{OUT} = 2.5\text{ V}$

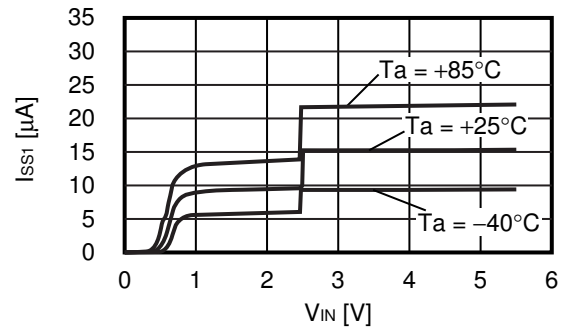

6.3  $V_{OUT} = 3.5\text{ V}$

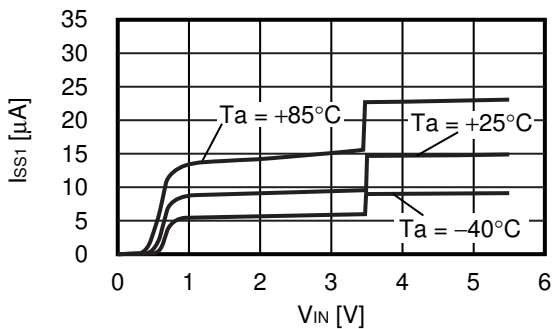

**7. Ripple rejection (Ta = +25°C)**

**7.1 V<sub>OUT</sub> = 1.0 V**

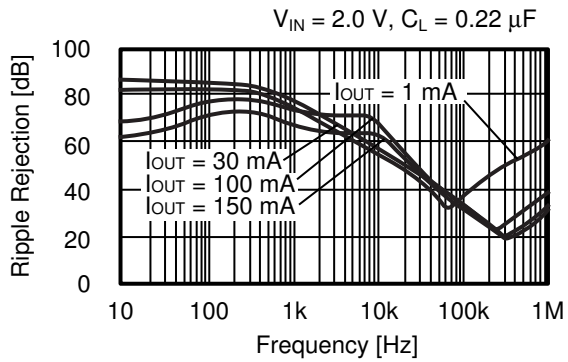

**7.2 V<sub>OUT</sub> = 2.5 V**

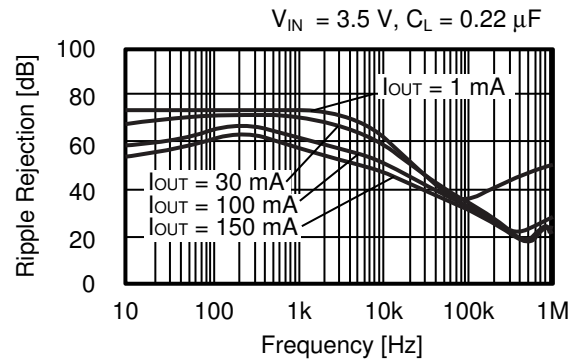

**7.3 V<sub>OUT</sub> = 3.5 V**

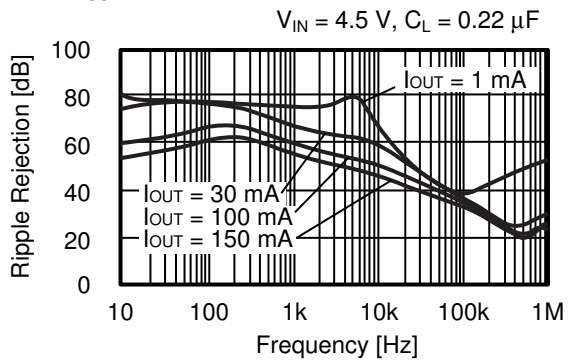

■ Reference Data

1. Transient response characteristics when input ( $T_a = +25^\circ\text{C}$ )

1.1  $V_{OUT} = 1.0\text{ V}$

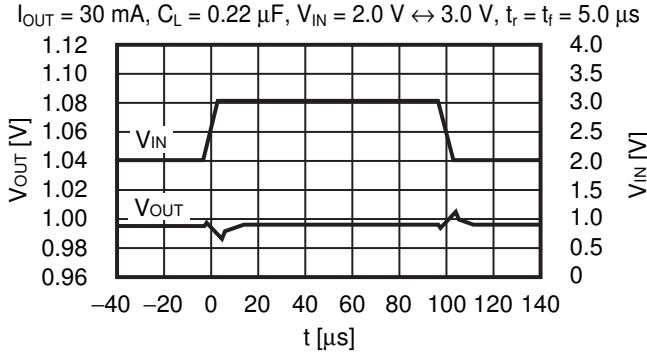

1.2  $V_{OUT} = 2.5\text{ V}$

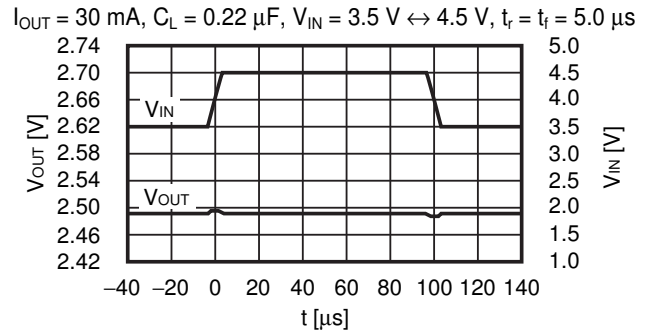

1.3  $V_{OUT} = 3.5\text{ V}$

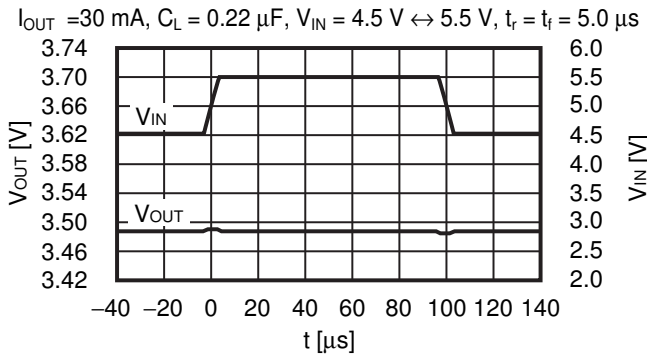

2. Transient response characteristics of load ( $T_a = +25^\circ\text{C}$ )

2.1  $V_{OUT} = 1.0\text{ V}$

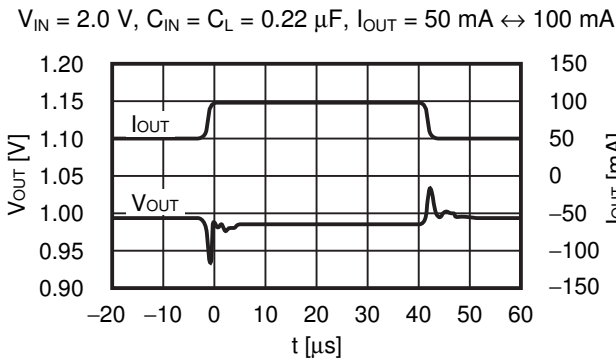

2.2  $V_{OUT} = 2.5\text{ V}$

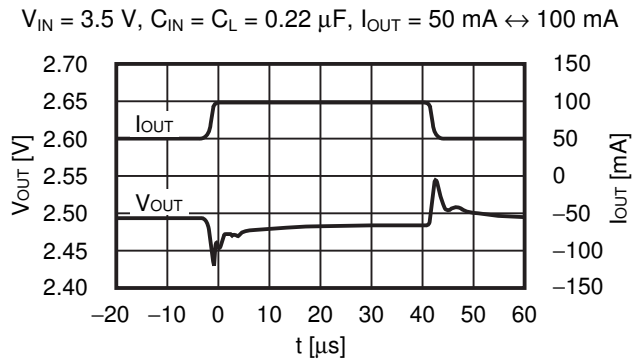

2.3  $V_{OUT} = 3.5\text{ V}$

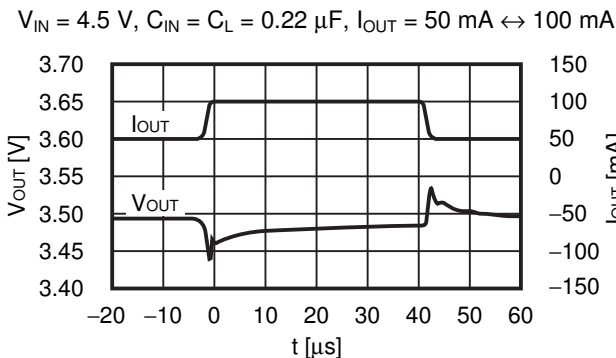

**3. Transient response characteristics of ON / OFF pin (Ta = +25°C)**

**3.1 V<sub>OUT</sub> = 1.0 V**

V<sub>IN</sub> = 2.0 V, C<sub>IN</sub> = C<sub>L</sub> = 0.22 μF, I<sub>OUT</sub> = 100 mA,  
 V<sub>ON/OFF</sub> = 0 V → 2.0 V, t<sub>r</sub> = 1.0 μs

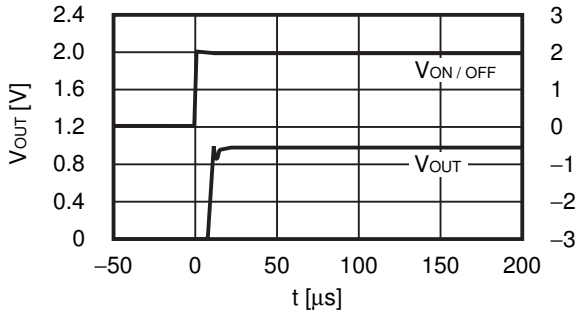

**3.2 V<sub>OUT</sub> = 2.5 V**

V<sub>IN</sub> = 3.5 V, C<sub>IN</sub> = C<sub>L</sub> = 0.22 μF, I<sub>OUT</sub> = 100 mA,  
 V<sub>ON/OFF</sub> = 0 V → 3.5 V, t<sub>r</sub> = 1.0 μs

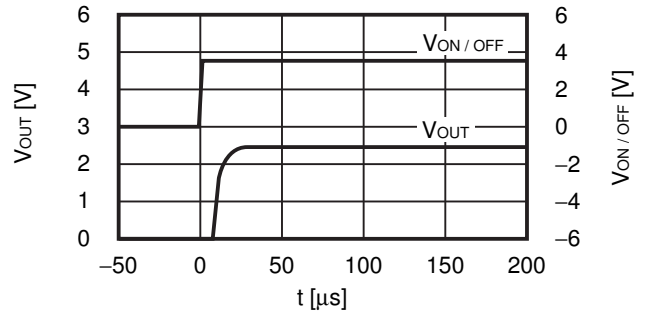

**3.3 V<sub>OUT</sub> = 3.5 V**

V<sub>IN</sub> = 4.5 V, C<sub>IN</sub> = C<sub>L</sub> = 0.22 μF, I<sub>OUT</sub> = 100 mA,  
 V<sub>ON/OFF</sub> = 0 V → 4.5 V, t<sub>r</sub> = 1.0 μs

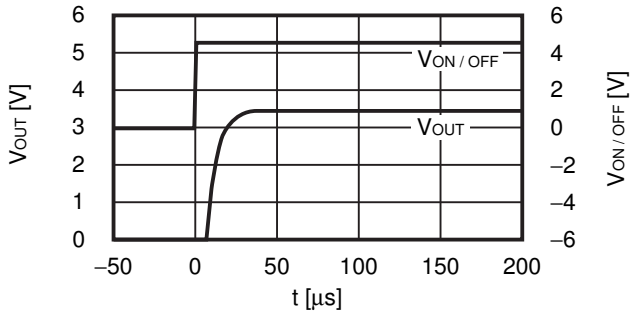

4. Output capacitance vs. Characteristics of discharge time (Ta = +25°C)

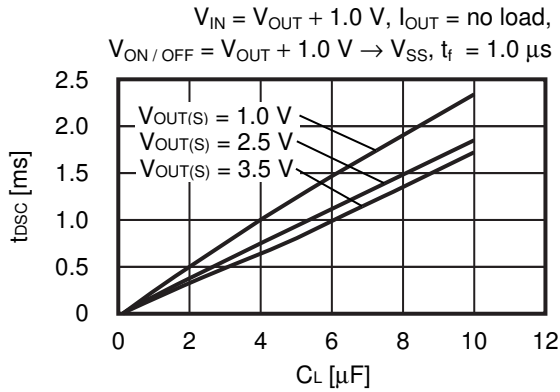

Figure 21 S-1312 Series A / B type (with discharge shunt function)

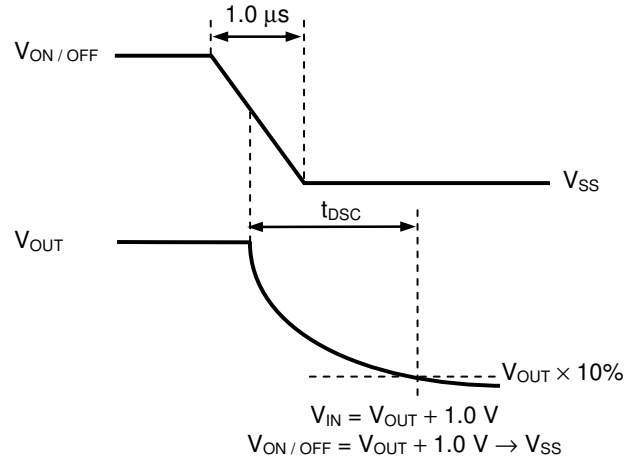

Figure 22 Measurement Condition of Discharge Time

5. Example of equivalent series resistance vs. Output current characteristics (Ta = +25°C)

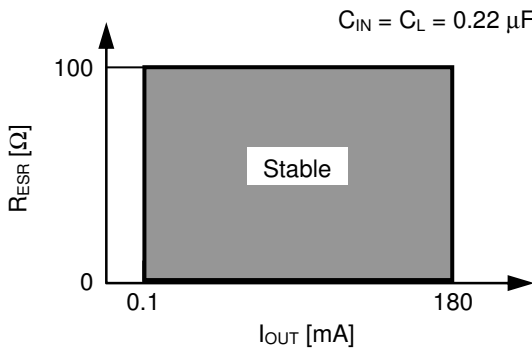
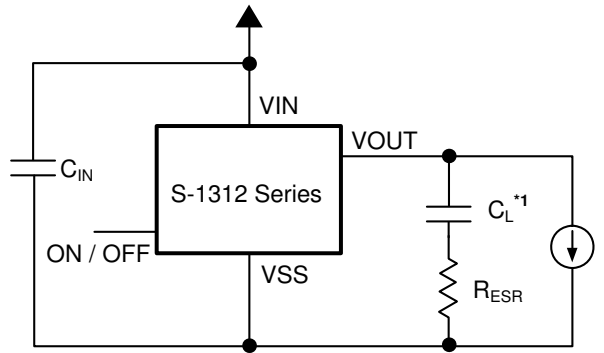

Figure 23



\*1.  $C_L$ : TDK Corporation C2012X7R1H224K (0.22  $\mu\text{F}$ )

Figure 24

■ **Marking Specifications**

1. **SOT-23-5**

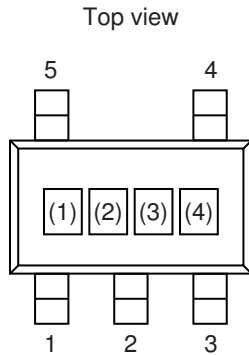

(1) to (3): Product code (Refer to **Product name vs. Product code**)  
 (4): Lot number

**Product name vs. Product code**

1.1 **S-1312 Series A type**

Product Name	Product Code		
	(1)	(2)	(3)
S-1312A10-M5T1U3	1	D	A
S-1312A11-M5T1U3	1	D	B
S-1312A12-M5T1U3	1	D	C
S-1312A1C-M5T1U3	1	D	4
S-1312A13-M5T1U3	1	D	D
S-1312A14-M5T1U3	1	D	E
S-1312A15-M5T1U3	1	D	F
S-1312A16-M5T1U3	1	D	G
S-1312A17-M5T1U3	1	D	H
S-1312A18-M5T1U3	1	D	J
S-1312A1J-M5T1U3	1	D	K
S-1312A19-M5T1U3	1	D	L
S-1312A20-M5T1U3	1	D	M
S-1312A21-M5T1U3	1	D	N
S-1312A22-M5T1U3	1	D	O
S-1312A23-M5T1U3	1	D	P
S-1312A24-M5T1U3	1	D	Q
S-1312A25-M5T1U3	1	D	R
S-1312A26-M5T1U3	1	D	S
S-1312A27-M5T1U3	1	D	T
S-1312A28-M5T1U3	1	D	U
S-1312A2J-M5T1U3	1	D	V
S-1312A29-M5T1U3	1	D	W
S-1312A30-M5T1U3	1	D	X
S-1312A31-M5T1U3	1	D	Y
S-1312A32-M5T1U3	1	D	Z
S-1312A33-M5T1U3	1	D	1
S-1312A34-M5T1U3	1	D	2
S-1312A35-M5T1U3	1	D	3

1.2 **S-1312 Series B type**

Product Name	Product Code		
	(1)	(2)	(3)
S-1312B10-M5T1U3	1	E	A
S-1312B11-M5T1U3	1	E	B
S-1312B12-M5T1U3	1	E	C
S-1312B13-M5T1U3	1	E	D
S-1312B14-M5T1U3	1	E	E
S-1312B15-M5T1U3	1	E	F
S-1312B16-M5T1U3	1	E	G
S-1312B17-M5T1U3	1	E	H
S-1312B18-M5T1U3	1	E	J
S-1312B1J-M5T1U3	1	E	K
S-1312B19-M5T1U3	1	E	L
S-1312B20-M5T1U3	1	E	M
S-1312B21-M5T1U3	1	E	N
S-1312B22-M5T1U3	1	E	O
S-1312B23-M5T1U3	1	E	P
S-1312B24-M5T1U3	1	E	Q
S-1312B25-M5T1U3	1	E	R
S-1312B26-M5T1U3	1	E	S
S-1312B27-M5T1U3	1	E	T
S-1312B28-M5T1U3	1	E	U
S-1312B2J-M5T1U3	1	E	V
S-1312B29-M5T1U3	1	E	W
S-1312B30-M5T1U3	1	E	X
S-1312B31-M5T1U3	1	E	Y
S-1312B32-M5T1U3	1	E	Z
S-1312B33-M5T1U3	1	E	1
S-1312B34-M5T1U3	1	E	2
S-1312B35-M5T1U3	1	E	3

1.3 S-1312 Series C type

Product Name	Product Code		
	(1)	(2)	(3)
S-1312C10-M5T1U3	1	F	A
S-1312C11-M5T1U3	1	F	B
S-1312C12-M5T1U3	1	F	C
S-1312C13-M5T1U3	1	F	D
S-1312C14-M5T1U3	1	F	E
S-1312C15-M5T1U3	1	F	F
S-1312C16-M5T1U3	1	F	G
S-1312C17-M5T1U3	1	F	H
S-1312C18-M5T1U3	1	F	J
S-1312C1J-M5T1U3	1	F	K
S-1312C19-M5T1U3	1	F	L
S-1312C20-M5T1U3	1	F	M
S-1312C21-M5T1U3	1	F	N
S-1312C22-M5T1U3	1	F	O
S-1312C23-M5T1U3	1	F	P
S-1312C24-M5T1U3	1	F	Q
S-1312C25-M5T1U3	1	F	R
S-1312C26-M5T1U3	1	F	S
S-1312C27-M5T1U3	1	F	T
S-1312C28-M5T1U3	1	F	U
S-1312C2J-M5T1U3	1	F	V
S-1312C29-M5T1U3	1	F	W
S-1312C30-M5T1U3	1	F	X
S-1312C31-M5T1U3	1	F	Y
S-1312C32-M5T1U3	1	F	Z
S-1312C33-M5T1U3	1	F	1
S-1312C34-M5T1U3	1	F	2
S-1312C35-M5T1U3	1	F	3

1.4 S-1312 Series D type

Product Name	Product Code		
	(1)	(2)	(3)
S-1312D10-M5T1U3	1	G	A
S-1312D11-M5T1U3	1	G	B
S-1312D12-M5T1U3	1	G	C
S-1312D13-M5T1U3	1	G	D
S-1312D14-M5T1U3	1	G	E
S-1312D15-M5T1U3	1	G	F
S-1312D16-M5T1U3	1	G	G
S-1312D17-M5T1U3	1	G	H
S-1312D18-M5T1U3	1	G	J
S-1312D1J-M5T1U3	1	G	K
S-1312D19-M5T1U3	1	G	L
S-1312D20-M5T1U3	1	G	M
S-1312D21-M5T1U3	1	G	N
S-1312D22-M5T1U3	1	G	O
S-1312D23-M5T1U3	1	G	P
S-1312D24-M5T1U3	1	G	Q
S-1312D25-M5T1U3	1	G	R
S-1312D26-M5T1U3	1	G	S
S-1312D27-M5T1U3	1	G	T
S-1312D28-M5T1U3	1	G	U
S-1312D2J-M5T1U3	1	G	V
S-1312D29-M5T1U3	1	G	W
S-1312D30-M5T1U3	1	G	X
S-1312D31-M5T1U3	1	G	Y
S-1312D32-M5T1U3	1	G	Z
S-1312D33-M5T1U3	1	G	1
S-1312D34-M5T1U3	1	G	2
S-1312D35-M5T1U3	1	G	3

**2. HSNT-4 (1010)**

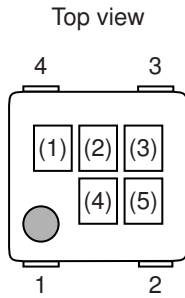

(1) to (3): Product code (Refer to **Product name vs. Product code**)  
 (4), (5): Lot number

**Product name vs. Product code**

**2.1 S-1312 Series A type**

Product Name	Product Code		
	(1)	(2)	(3)
S-1312A10-A4T2U3	1	D	A
S-1312A11-A4T2U3	1	D	B
S-1312A12-A4T2U3	1	D	C
S-1312A1C-A4T2U3	1	D	4
S-1312A13-A4T2U3	1	D	D
S-1312A14-A4T2U3	1	D	E
S-1312A15-A4T2U3	1	D	F
S-1312A16-A4T2U3	1	D	G
S-1312A17-A4T2U3	1	D	H
S-1312A18-A4T2U3	1	D	J
S-1312A1J-A4T2U3	1	D	K
S-1312A19-A4T2U3	1	D	L
S-1312A20-A4T2U3	1	D	M
S-1312A21-A4T2U3	1	D	N
S-1312A22-A4T2U3	1	D	O
S-1312A23-A4T2U3	1	D	P
S-1312A24-A4T2U3	1	D	Q
S-1312A25-A4T2U3	1	D	R
S-1312A26-A4T2U3	1	D	S
S-1312A27-A4T2U3	1	D	T
S-1312A28-A4T2U3	1	D	U
S-1312A2J-A4T2U3	1	D	V
S-1312A29-A4T2U3	1	D	W
S-1312A30-A4T2U3	1	D	X
S-1312A31-A4T2U3	1	D	Y
S-1312A32-A4T2U3	1	D	Z
S-1312A33-A4T2U3	1	D	1
S-1312A34-A4T2U3	1	D	2
S-1312A35-A4T2U3	1	D	3

**2.2 S-1312 Series B type**

Product Name	Product Code		
	(1)	(2)	(3)
S-1312B10-A4T2U3	1	E	A
S-1312B11-A4T2U3	1	E	B
S-1312B12-A4T2U3	1	E	C
S-1312B13-A4T2U3	1	E	D
S-1312B14-A4T2U3	1	E	E
S-1312B15-A4T2U3	1	E	F
S-1312B16-A4T2U3	1	E	G
S-1312B17-A4T2U3	1	E	H
S-1312B18-A4T2U3	1	E	J
S-1312B1J-A4T2U3	1	E	K
S-1312B19-A4T2U3	1	E	L
S-1312B20-A4T2U3	1	E	M
S-1312B21-A4T2U3	1	E	N
S-1312B22-A4T2U3	1	E	O
S-1312B23-A4T2U3	1	E	P
S-1312B24-A4T2U3	1	E	Q
S-1312B25-A4T2U3	1	E	R
S-1312B26-A4T2U3	1	E	S
S-1312B27-A4T2U3	1	E	T
S-1312B28-A4T2U3	1	E	U
S-1312B2J-A4T2U3	1	E	V
S-1312B29-A4T2U3	1	E	W
S-1312B30-A4T2U3	1	E	X
S-1312B31-A4T2U3	1	E	Y
S-1312B32-A4T2U3	1	E	Z
S-1312B33-A4T2U3	1	E	1
S-1312B34-A4T2U3	1	E	2
S-1312B35-A4T2U3	1	E	3



**2.3 S-1312 Series C type**

Product Name	Product Code		
	(1)	(2)	(3)
S-1312C10-A4T2U3	1	F	A
S-1312C11-A4T2U3	1	F	B
S-1312C12-A4T2U3	1	F	C
S-1312C13-A4T2U3	1	F	D
S-1312C14-A4T2U3	1	F	E
S-1312C15-A4T2U3	1	F	F
S-1312C16-A4T2U3	1	F	G
S-1312C17-A4T2U3	1	F	H
S-1312C18-A4T2U3	1	F	J
S-1312C1J-A4T2U3	1	F	K
S-1312C19-A4T2U3	1	F	L
S-1312C20-A4T2U3	1	F	M
S-1312C21-A4T2U3	1	F	N
S-1312C22-A4T2U3	1	F	O
S-1312C23-A4T2U3	1	F	P
S-1312C24-A4T2U3	1	F	Q
S-1312C25-A4T2U3	1	F	R
S-1312C26-A4T2U3	1	F	S
S-1312C27-A4T2U3	1	F	T
S-1312C28-A4T2U3	1	F	U
S-1312C2J-A4T2U3	1	F	V
S-1312C29-A4T2U3	1	F	W
S-1312C30-A4T2U3	1	F	X
S-1312C31-A4T2U3	1	F	Y
S-1312C32-A4T2U3	1	F	Z
S-1312C33-A4T2U3	1	F	1
S-1312C34-A4T2U3	1	F	2
S-1312C35-A4T2U3	1	F	3

**2.4 S-1312 Series D type**

Product Name	Product Code		
	(1)	(2)	(3)
S-1312D10-A4T2U3	1	G	A
S-1312D11-A4T2U3	1	G	B
S-1312D12-A4T2U3	1	G	C
S-1312D13-A4T2U3	1	G	D
S-1312D14-A4T2U3	1	G	E
S-1312D15-A4T2U3	1	G	F
S-1312D16-A4T2U3	1	G	G
S-1312D17-A4T2U3	1	G	H
S-1312D18-A4T2U3	1	G	J
S-1312D1J-A4T2U3	1	G	K
S-1312D19-A4T2U3	1	G	L
S-1312D20-A4T2U3	1	G	M
S-1312D21-A4T2U3	1	G	N
S-1312D22-A4T2U3	1	G	O
S-1312D23-A4T2U3	1	G	P
S-1312D24-A4T2U3	1	G	Q
S-1312D25-A4T2U3	1	G	R
S-1312D26-A4T2U3	1	G	S
S-1312D27-A4T2U3	1	G	T
S-1312D28-A4T2U3	1	G	U
S-1312D2J-A4T2U3	1	G	V
S-1312D29-A4T2U3	1	G	W
S-1312D30-A4T2U3	1	G	X
S-1312D31-A4T2U3	1	G	Y
S-1312D32-A4T2U3	1	G	Z
S-1312D33-A4T2U3	1	G	1
S-1312D34-A4T2U3	1	G	2
S-1312D35-A4T2U3	1	G	3

**3. HSNT-4 (0808)**

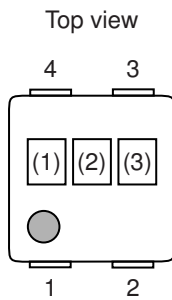

(1) to (3): Product code (Refer to **Product name vs. Product code**)

**Product name vs. Product code**

**3.1 S-1312 Series A type**

Product Name	Product Code		
	(1)	(2)	(3)
S-1312A10-A4T1U3	1	D	A
S-1312A11-A4T1U3	1	D	B
S-1312A12-A4T1U3	1	D	C
S-1312A1C-A4T1U3	1	D	4
S-1312A13-A4T1U3	1	D	D
S-1312A14-A4T1U3	1	D	E
S-1312A15-A4T1U3	1	D	F
S-1312A16-A4T1U3	1	D	G
S-1312A17-A4T1U3	1	D	H
S-1312A18-A4T1U3	1	D	J
S-1312A1J-A4T1U3	1	D	K
S-1312A19-A4T1U3	1	D	L
S-1312A20-A4T1U3	1	D	M
S-1312A21-A4T1U3	1	D	N
S-1312A22-A4T1U3	1	D	O
S-1312A23-A4T1U3	1	D	P
S-1312A24-A4T1U3	1	D	Q
S-1312A25-A4T1U3	1	D	R
S-1312A26-A4T1U3	1	D	S
S-1312A27-A4T1U3	1	D	T
S-1312A28-A4T1U3	1	D	U
S-1312A2J-A4T1U3	1	D	V
S-1312A29-A4T1U3	1	D	W
S-1312A30-A4T1U3	1	D	X
S-1312A31-A4T1U3	1	D	Y
S-1312A32-A4T1U3	1	D	Z
S-1312A33-A4T1U3	1	D	1
S-1312A34-A4T1U3	1	D	2
S-1312A35-A4T1U3	1	D	3

**3.2 S-1312 Series B type**

Product Name	Product Code		
	(1)	(2)	(3)
S-1312B10-A4T1U3	1	E	A
S-1312B11-A4T1U3	1	E	B
S-1312B12-A4T1U3	1	E	C
S-1312B13-A4T1U3	1	E	D
S-1312B14-A4T1U3	1	E	E
S-1312B15-A4T1U3	1	E	F
S-1312B16-A4T1U3	1	E	G
S-1312B17-A4T1U3	1	E	H
S-1312B18-A4T1U3	1	E	J
S-1312B1J-A4T1U3	1	E	K
S-1312B19-A4T1U3	1	E	L
S-1312B20-A4T1U3	1	E	M
S-1312B21-A4T1U3	1	E	N
S-1312B22-A4T1U3	1	E	O
S-1312B23-A4T1U3	1	E	P
S-1312B24-A4T1U3	1	E	Q
S-1312B25-A4T1U3	1	E	R
S-1312B26-A4T1U3	1	E	S
S-1312B27-A4T1U3	1	E	T
S-1312B28-A4T1U3	1	E	U
S-1312B2J-A4T1U3	1	E	V
S-1312B29-A4T1U3	1	E	W
S-1312B30-A4T1U3	1	E	X
S-1312B31-A4T1U3	1	E	Y
S-1312B32-A4T1U3	1	E	Z
S-1312B33-A4T1U3	1	E	1
S-1312B34-A4T1U3	1	E	2
S-1312B35-A4T1U3	1	E	3

**3.3 S-1312 Series C type**

Product Name	Product Code		
	(1)	(2)	(3)
S-1312C10-A4T1U3	1	F	A
S-1312C11-A4T1U3	1	F	B
S-1312C12-A4T1U3	1	F	C
S-1312C13-A4T1U3	1	F	D
S-1312C14-A4T1U3	1	F	E
S-1312C15-A4T1U3	1	F	F
S-1312C16-A4T1U3	1	F	G
S-1312C17-A4T1U3	1	F	H
S-1312C18-A4T1U3	1	F	J
S-1312C1J-A4T1U3	1	F	K
S-1312C19-A4T1U3	1	F	L
S-1312C20-A4T1U3	1	F	M
S-1312C21-A4T1U3	1	F	N
S-1312C22-A4T1U3	1	F	O
S-1312C23-A4T1U3	1	F	P
S-1312C24-A4T1U3	1	F	Q
S-1312C25-A4T1U3	1	F	R
S-1312C26-A4T1U3	1	F	S
S-1312C27-A4T1U3	1	F	T
S-1312C28-A4T1U3	1	F	U
S-1312C2J-A4T1U3	1	F	V
S-1312C29-A4T1U3	1	F	W
S-1312C30-A4T1U3	1	F	X
S-1312C31-A4T1U3	1	F	Y
S-1312C32-A4T1U3	1	F	Z
S-1312C33-A4T1U3	1	F	1
S-1312C34-A4T1U3	1	F	2
S-1312C35-A4T1U3	1	F	3

**3.4 S-1312 Series D type**

Product Name	Product Code		
	(1)	(2)	(3)
S-1312D10-A4T1U3	1	G	A
S-1312D11-A4T1U3	1	G	B
S-1312D12-A4T1U3	1	G	C
S-1312D13-A4T1U3	1	G	D
S-1312D14-A4T1U3	1	G	E
S-1312D15-A4T1U3	1	G	F
S-1312D16-A4T1U3	1	G	G
S-1312D17-A4T1U3	1	G	H
S-1312D18-A4T1U3	1	G	J
S-1312D1J-A4T1U3	1	G	K
S-1312D19-A4T1U3	1	G	L
S-1312D20-A4T1U3	1	G	M
S-1312D21-A4T1U3	1	G	N
S-1312D22-A4T1U3	1	G	O
S-1312D23-A4T1U3	1	G	P
S-1312D24-A4T1U3	1	G	Q
S-1312D25-A4T1U3	1	G	R
S-1312D26-A4T1U3	1	G	S
S-1312D27-A4T1U3	1	G	T
S-1312D28-A4T1U3	1	G	U
S-1312D2J-A4T1U3	1	G	V
S-1312D29-A4T1U3	1	G	W
S-1312D30-A4T1U3	1	G	X
S-1312D31-A4T1U3	1	G	Y
S-1312D32-A4T1U3	1	G	Z
S-1312D33-A4T1U3	1	G	1
S-1312D34-A4T1U3	1	G	2
S-1312D35-A4T1U3	1	G	3

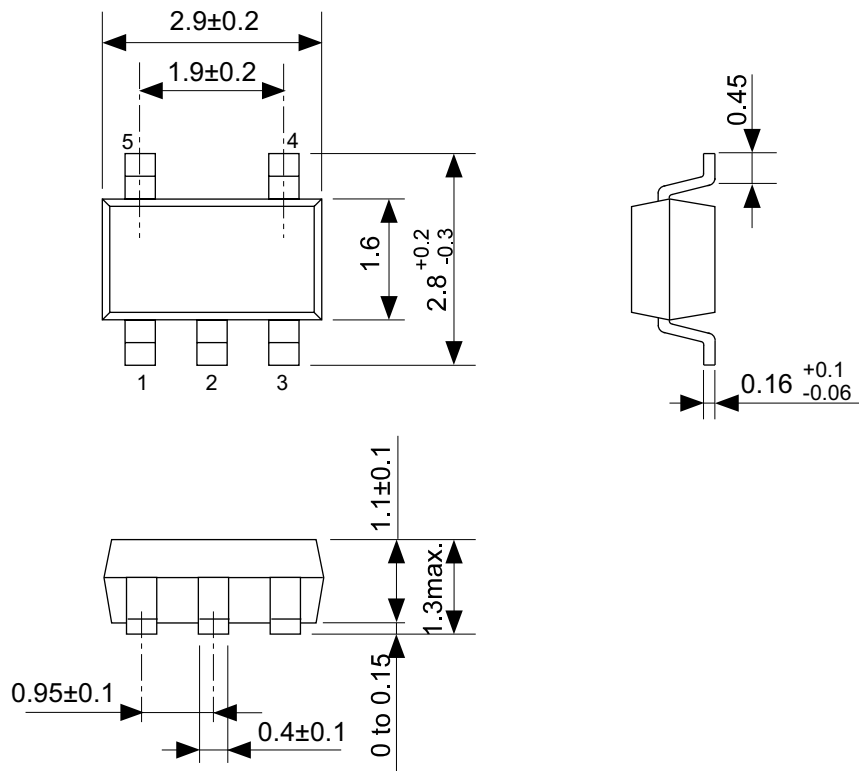

No. MP005-A-P-SD-1.2

TITLE	SOT235-A-PKG Dimensions
No.	MP005-A-P-SD-1.2
SCALE	
UNIT	mm
Seiko Instruments Inc.	

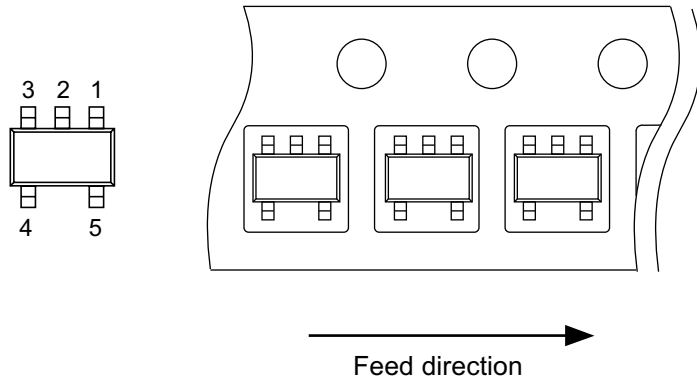
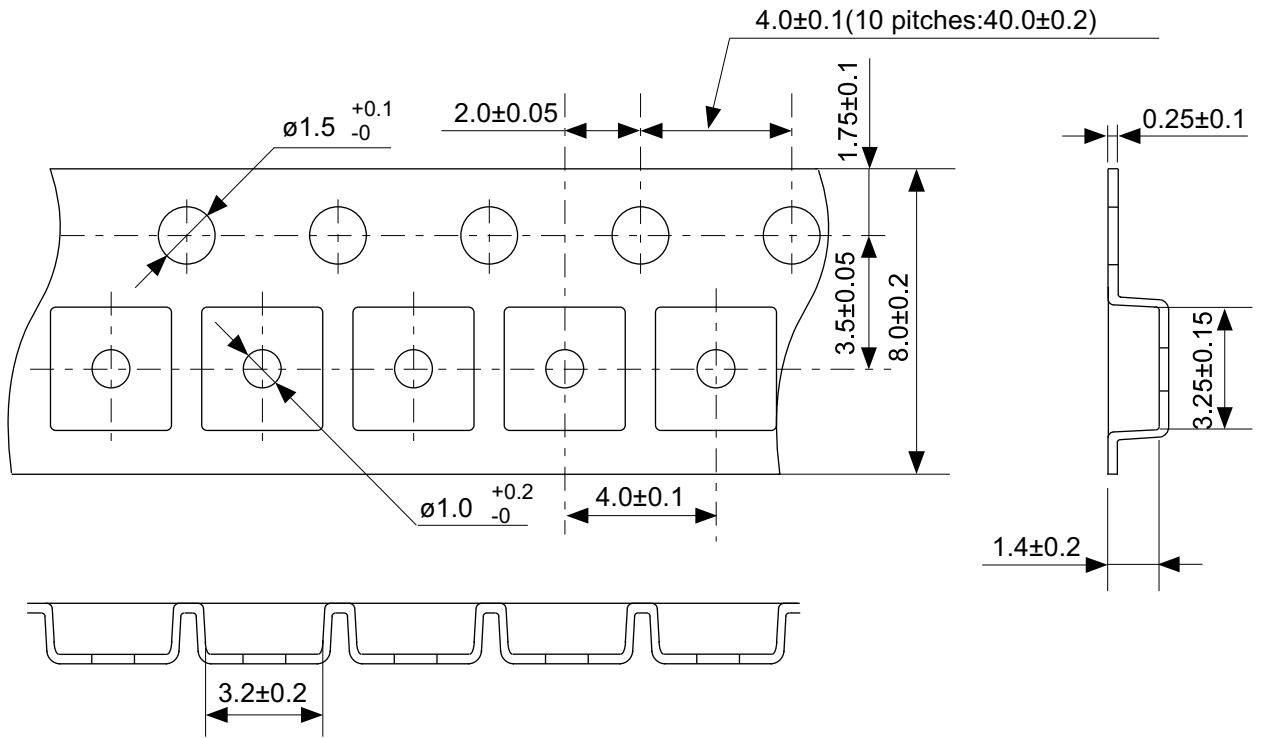

No. MP005-A-C-SD-2.1

TITLE	SOT235-A-Carrier Tape
No.	MP005-A-C-SD-2.1
SCALE	
UNIT	mm
Seiko Instruments Inc.	

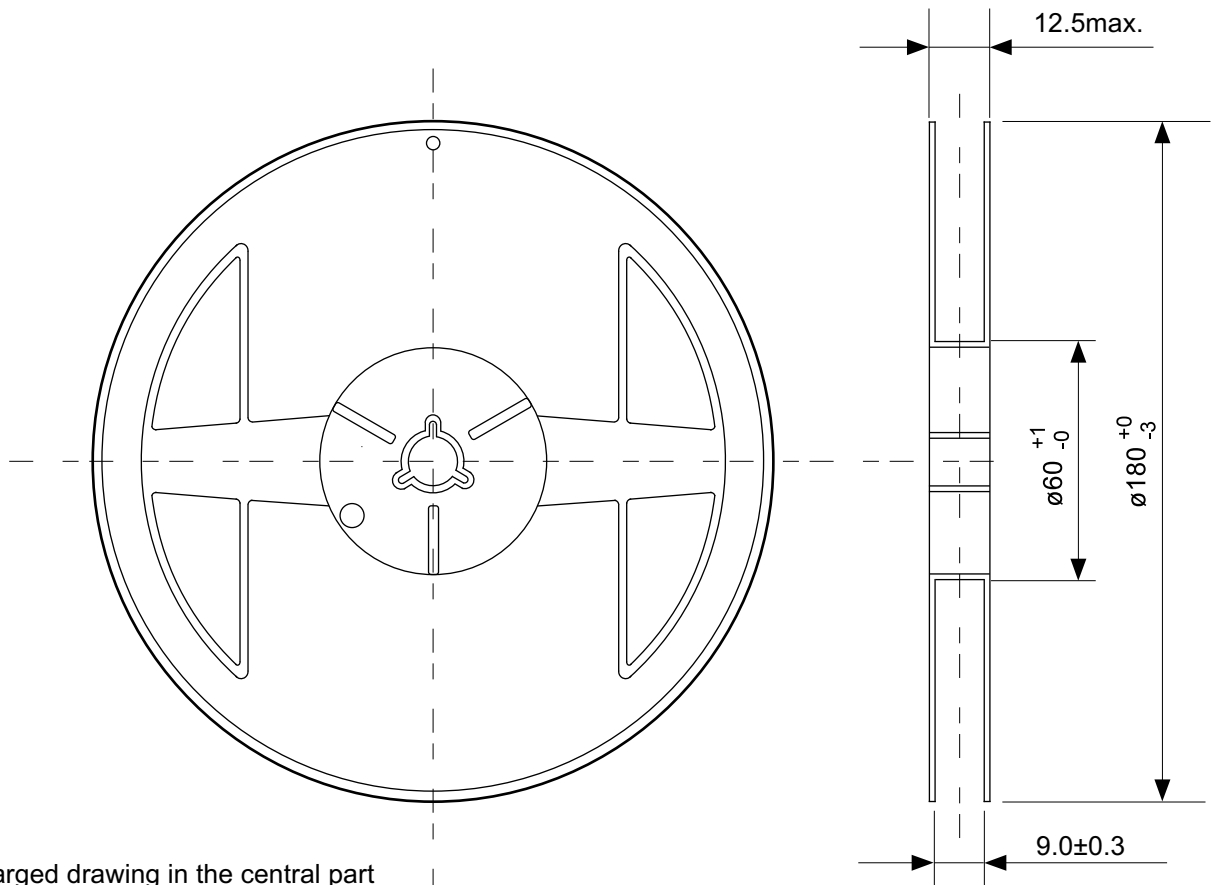

Enlarged drawing in the central part

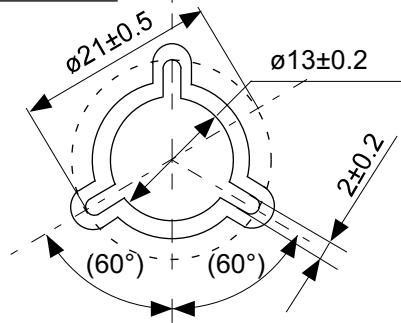

No. MP005-A-R-SD-1.1

TITLE	SOT235-A-Reel		
No.	MP005-A-R-SD-1.1		
SCALE		QTY.	3,000
UNIT	mm		
Seiko Instruments Inc.			

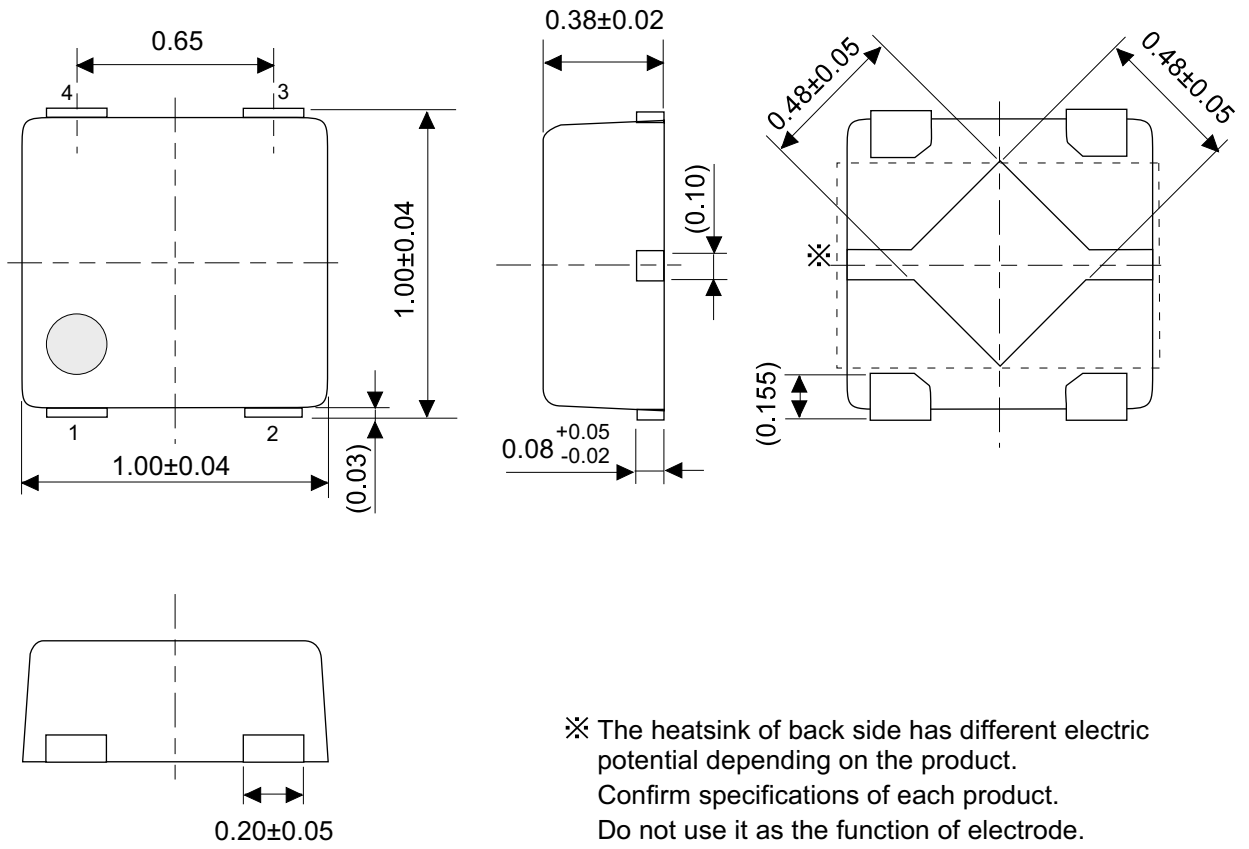

※ The heatsink of back side has different electric potential depending on the product.  
 Confirm specifications of each product.  
 Do not use it as the function of electrode.

No. PL004-A-P-SD-1.0

TITLE	HSNT-4-B-PKG Dimensions
No.	PL004-A-P-SD-1.0
SCALE	
UNIT	mm
Seiko Instruments Inc.	

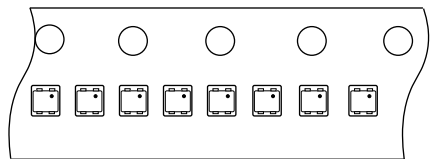
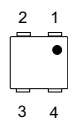
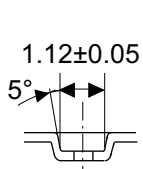
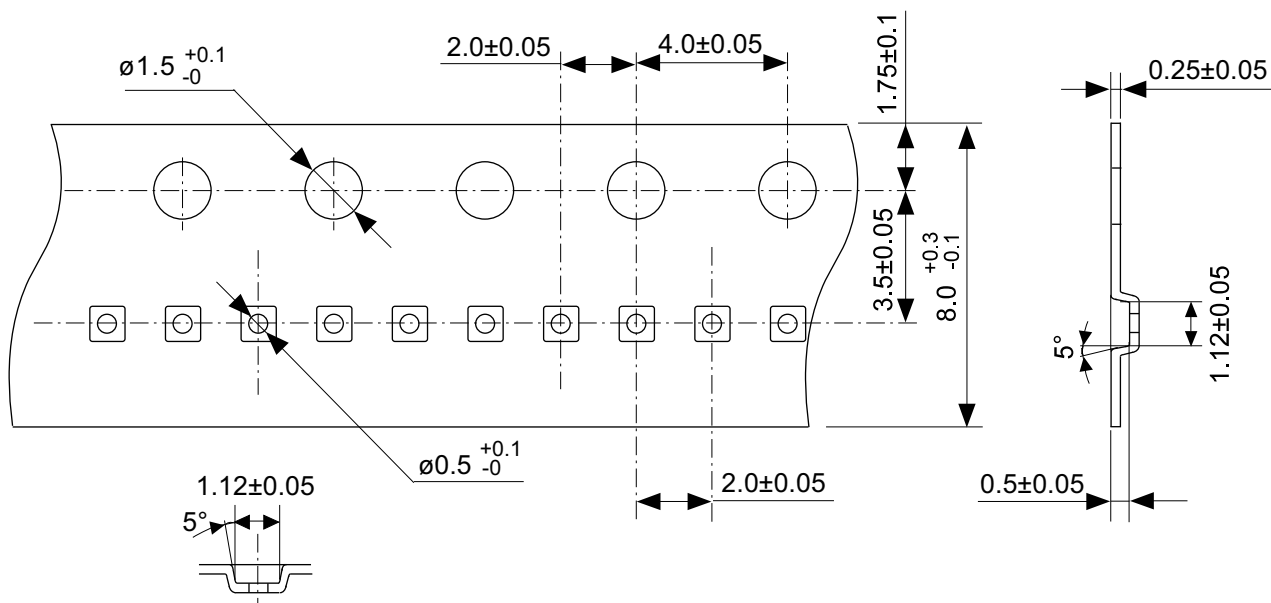

→  
Feed direction

No. PL004-A-C-SD-1.0

TITLE	HSNT-4-B-Carrier Tape
No.	PL004-A-C-SD-1.0
SCALE	
UNIT	mm

Seiko Instruments Inc.



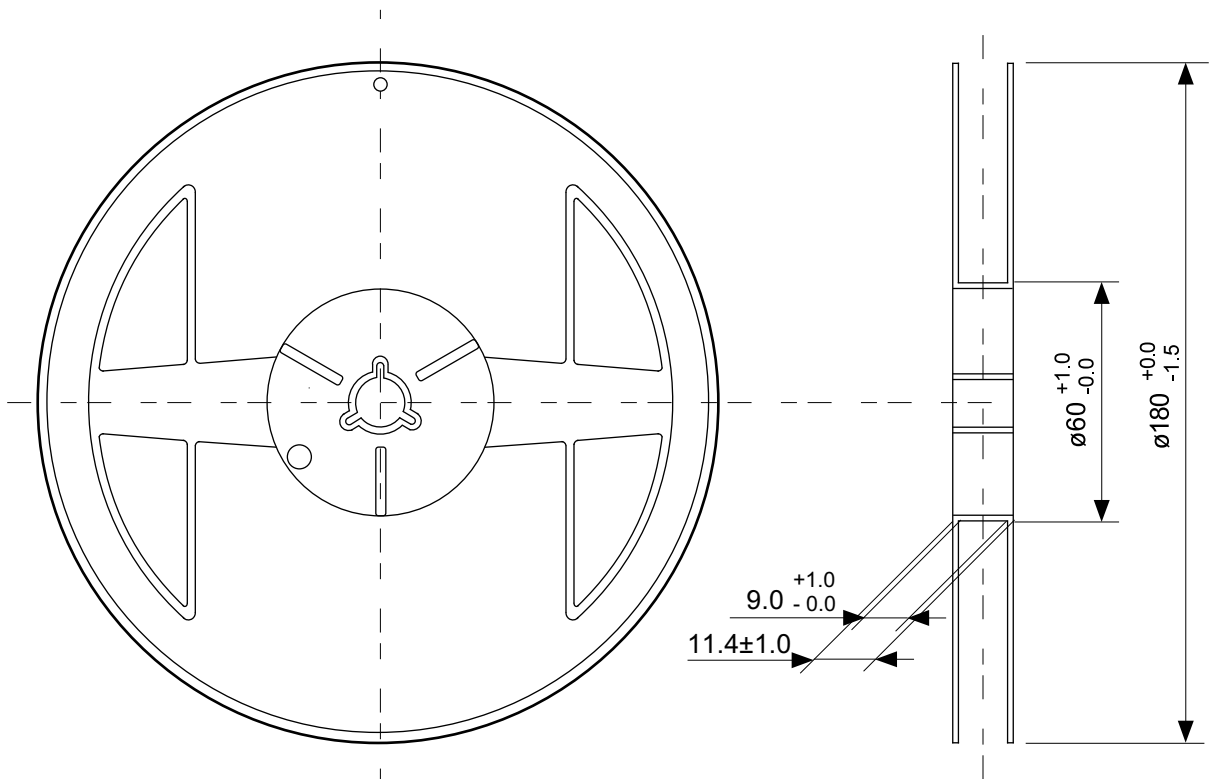

Enlarged drawing in the central part

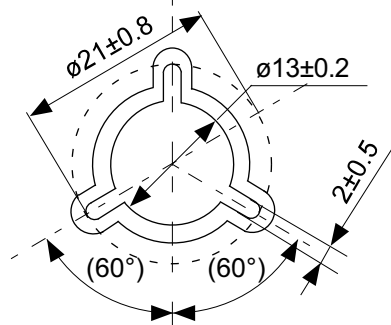

No. PL004-A-R-SD-1.0

TITLE	HSNT-4-B-Reel		
No.	PL004-A-R-SD-1.0		
SCALE		QTY.	10,000
UNIT	mm		
Seiko Instruments Inc.			

## Land Pattern

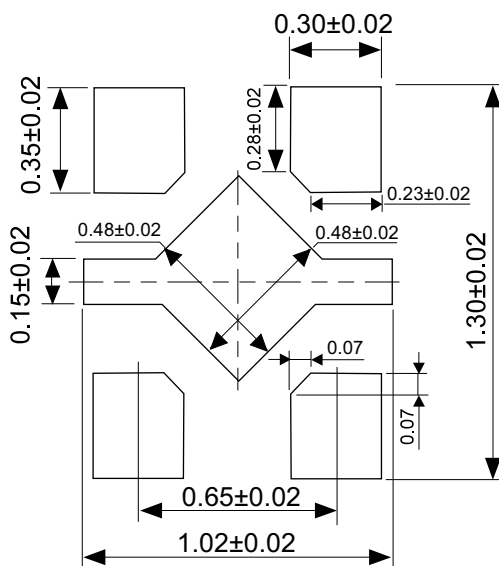

Caution It is recommended to solder the heatsink to a board in order to ensure the heat radiation.

注意 放熱性を確保する為に、PKGの裏面放熱板(ヒートシンク)を基板に半田付けする事を推奨いたします。

## Metal Mask Pattern

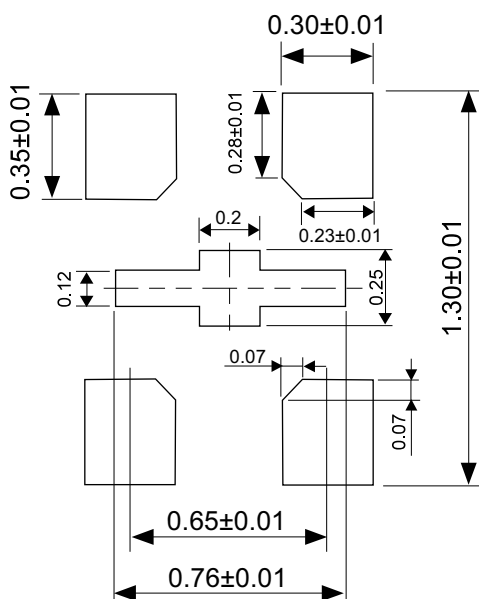

No. PL004-A-L-SD-1.0

TITLE	HSNT-4-B-Land Recommendation
No.	PL004-A-L-SD-1.0
SCALE	
UNIT	mm
Seiko Instruments Inc.	

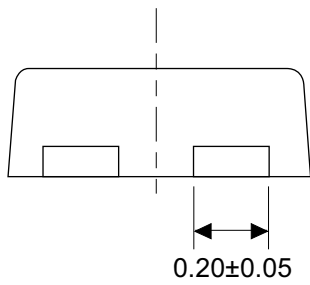
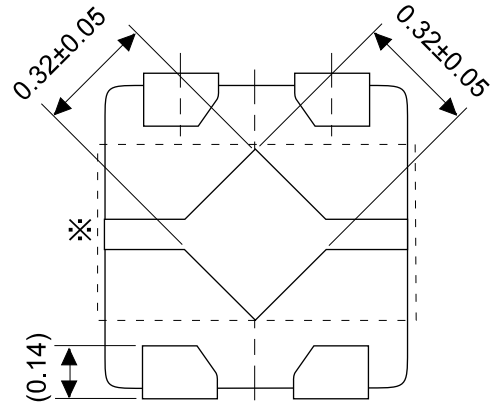
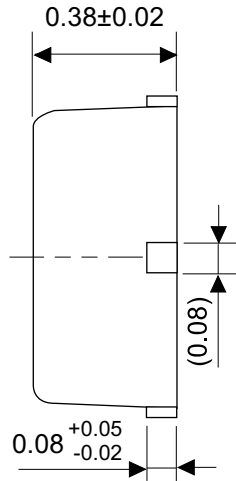
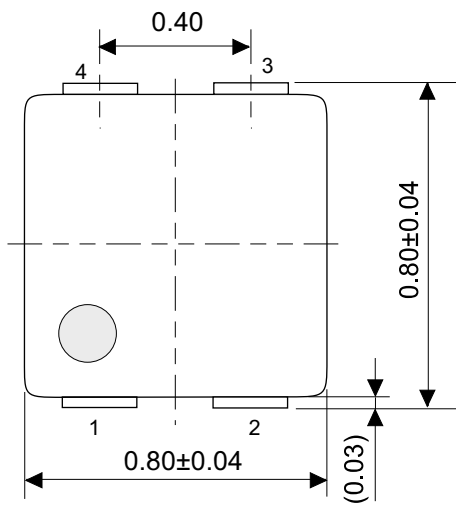

※ The heatsink of back side has different electric potential depending on the product.  
 Confirm specifications of each product.  
 Do not use it as the function of electrode.

No. PK004-A-P-SD-2.0

TITLE	HSNT-4-A-PKG Dimensions
No.	PK004-A-P-SD-2.0
SCALE	
UNIT	mm
Seiko Instruments Inc.	

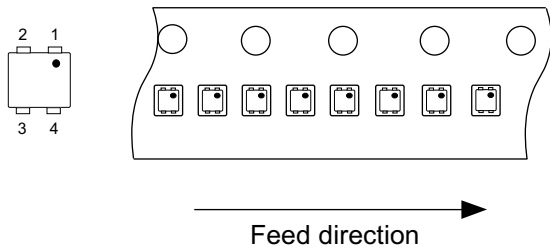
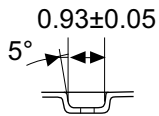
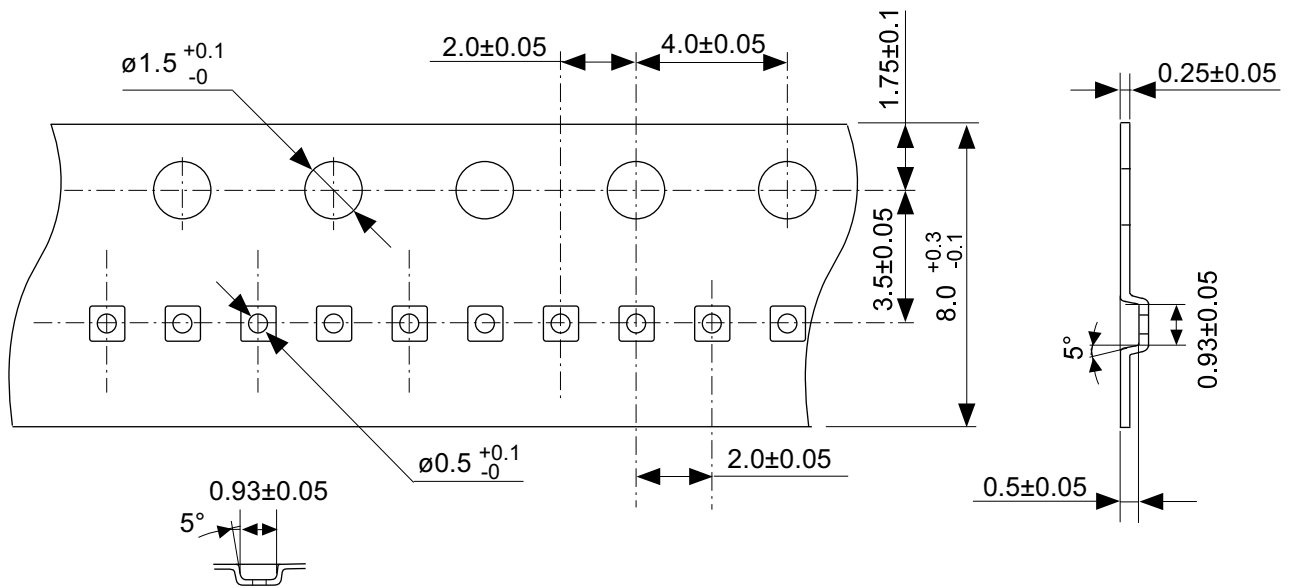

No. PK004-A-C-SD-2.0

TITLE	HSNT-4-A-Carrier Tape
No.	PK004-A-C-SD-2.0
SCALE	
UNIT	mm
Seiko Instruments Inc.	

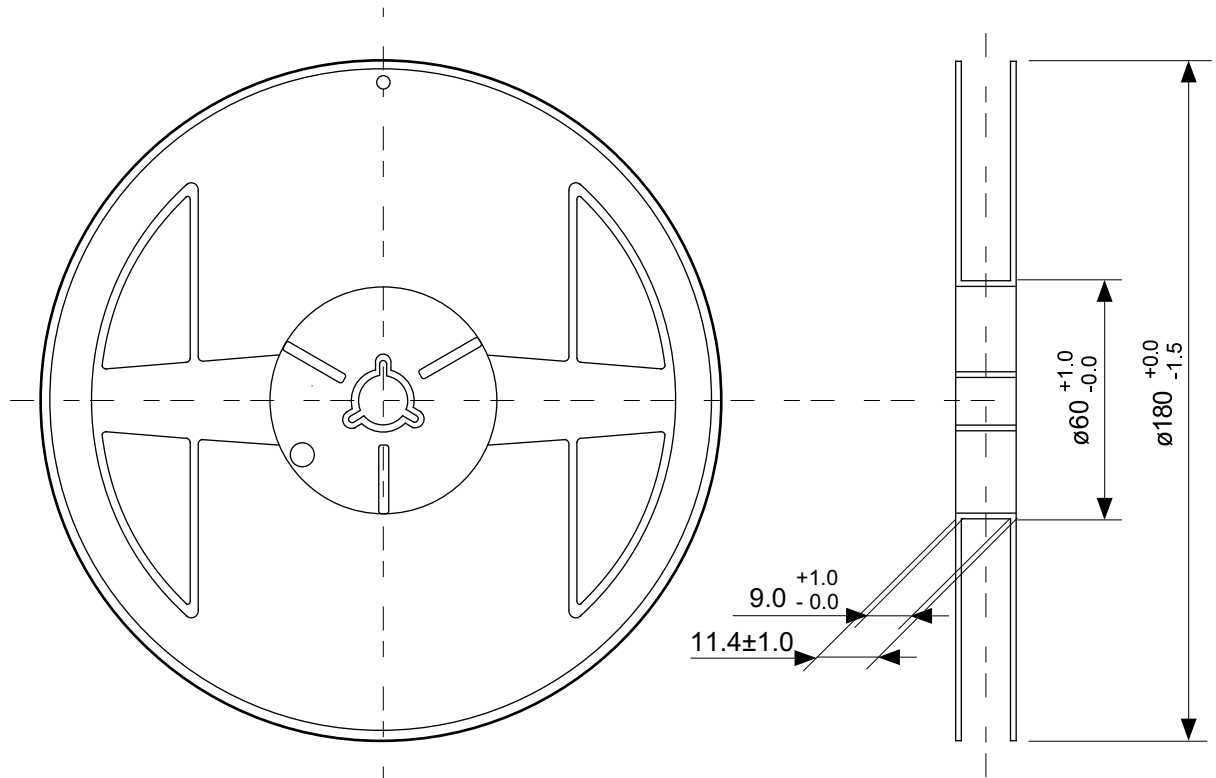

Enlarged drawing in the central part

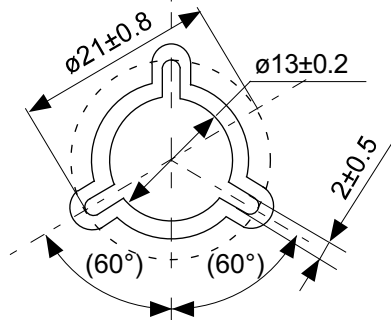

No. PK004-A-R-SD-2.0

TITLE	HSNT-4-A-Reel		
No.	PK004-A-R-SD-2.0		
SCALE		QTY.	10,000
UNIT	mm		
Seiko Instruments Inc.			

## Land Pattern

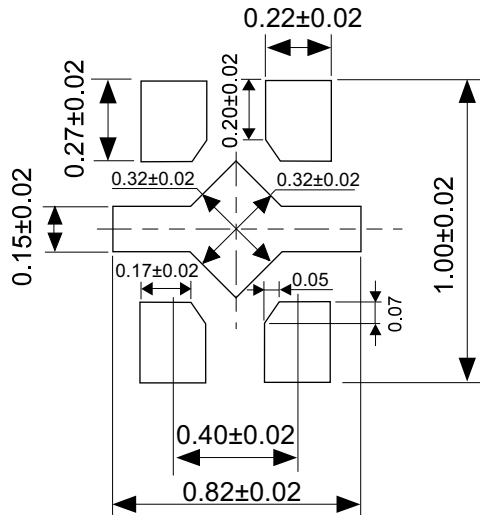

Caution It is recommended to solder the heatsink to a board in order to ensure the heat radiation.

注意 放熱性を確保する為に、PKGの裏面放熱板(ヒートシンク)を基板に半田付けする事を推奨いたします。

## Metal Mask Pattern

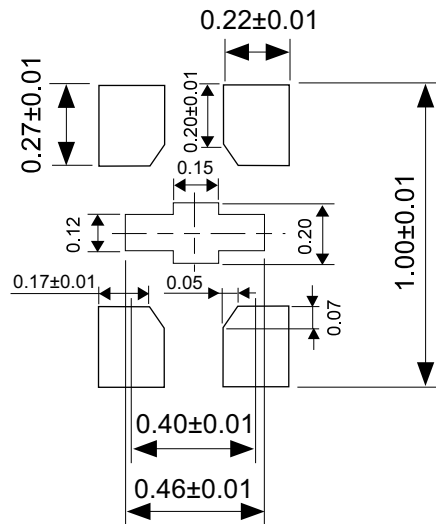

No. PK004-A-L-SD-2.0

TITLE	HSNT-4-A-Land Recommendation
No.	PK004-A-L-SD-2.0
SCALE	
UNIT	mm
Seiko Instruments Inc.	



Seiko Instruments Inc.  
[www.sii-ic.com](http://www.sii-ic.com)

- The information described herein is subject to change without notice.
- Seiko Instruments Inc. is not responsible for any problems caused by circuits or diagrams described herein whose related industrial properties, patents, or other rights belong to third parties. The application circuit examples explain typical applications of the products, and do not guarantee the success of any specific mass-production design.
- When the products described herein are regulated products subject to the Wassenaar Arrangement or other agreements, they may not be exported without authorization from the appropriate governmental authority.
- Use of the information described herein for other purposes and/or reproduction or copying without the express permission of Seiko Instruments Inc. is strictly prohibited.
- The products described herein cannot be used as part of any device or equipment affecting the human body, such as exercise equipment, medical equipment, security systems, gas equipment, vehicle equipment, in-vehicle equipment, aviation equipment, aerospace equipment, and nuclear-related equipment, without prior written permission of Seiko Instruments Inc.
- The products described herein are not designed to be radiation-proof.
- Although Seiko Instruments Inc. exerts the greatest possible effort to ensure high quality and reliability, the failure or malfunction of semiconductor products may occur. The user of these products should therefore give thorough consideration to safety design, including redundancy, fire-prevention measures, and malfunction prevention, to prevent any accidents, fires, or community damage that may ensue.