

REVERSE CURRENT PROTECTION CMOS VOLTAGE REGULATOR

The S-13R1 Series, developed by using the CMOS technology, is a positive voltage regulator IC of 150 mA output current, which has low dropout voltage, high-accuracy output voltage and low current consumption.

Even with low current consumption of 5 μ A typ., it has high ripple-rejection of 70 dB typ., and a ceramic capacitor of 1.0 μ F or more can be used as the input and output capacitors.

The S-13R1 Series includes an overcurrent protection circuit that prevents the load current from exceeding the current capacitance of the output transistor and a thermal shutdown circuit that prevents damage because of overheating.

Due to the built-in reverse current protection function, the reverse current flowing from the VOUT pin to the VIN pin can be controlled as the small value 0.09 μ A max. Therefore, IC protection diode is not needed.

■ Features

- Output voltage: 1.2 V to 4.0 V, selectable in 0.05 V step
- Input voltage: 2.0 V to 5.5 V
- Output voltage accuracy: $\pm 1.0\%$ (1.2 V to 1.45 V output product: ± 15 mV)
- Dropout voltage: 150 mV typ. (3.0 V output product, $I_{OUT} = 100$ mA)
- Current consumption:
 - During operation: 5 μ A typ., 9 μ A max.
 - During power-off: 0.1 μ A typ., 1.0 μ A max.
- Output current: Possible to output 150 mA ($V_{IN} \geq V_{OUT(S)} + 1.0$ V)*1
- Input and output capacitors: A ceramic capacitor of 1.0 μ F or more can be used.
- Ripple rejection: 70 dB typ. (3.0 V output product, $f = 1.0$ kHz)
- Reverse current protection function: $I_{REV} = 0.09$ μ A max.
- Built-in overcurrent protection circuit: Limits overcurrent of output transistor.
- Built-in thermal shutdown circuit: Prevents damage caused by heat.
- Built-in ON / OFF circuit: Ensures long battery life.
- Constant current source pull-down is selectable.
- Discharge shunt function is selectable.
- Operation temperature range: $T_a = -40^\circ\text{C}$ to $+85^\circ\text{C}$
- Lead-free (Sn 100%), halogen-free

*1. Attention should be paid to the power dissipation of the package when the output current is large.

■ Applications

- Constant-voltage power supply for battery-powered device
- Constant-voltage power supply for portable equipment
- Constant-voltage power supply for home electric appliance
- Constant-voltage power supply for mobile phone

■ Packages

- SOT-23-5
- SC-82AB
- HSNT-4 (1010)

■ **Block Diagrams**

1. **S-13R1 Series A type**

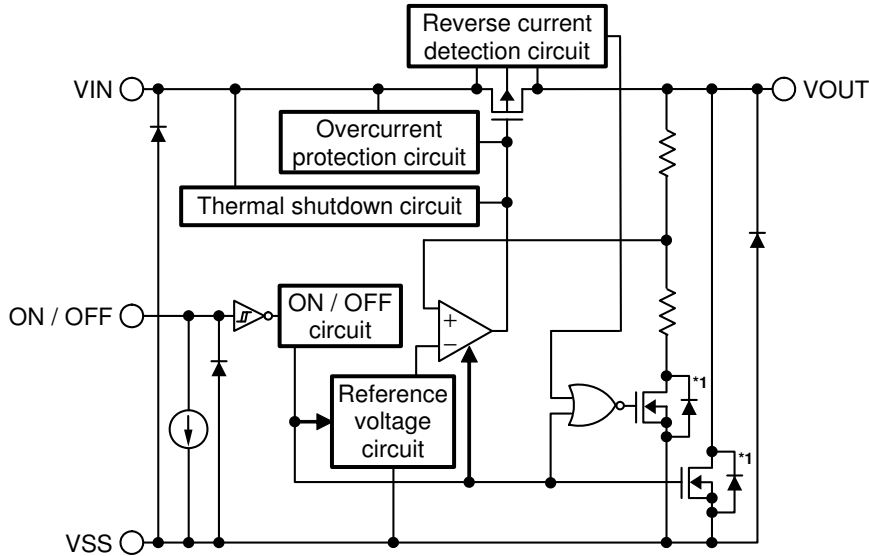

Function	Status
ON / OFF logic	Active "H"
Discharge shunt function	Available
Constant current source pull-down	Available

*1. Parasitic diode

Figure 1

2. **S-13R1 Series B type**

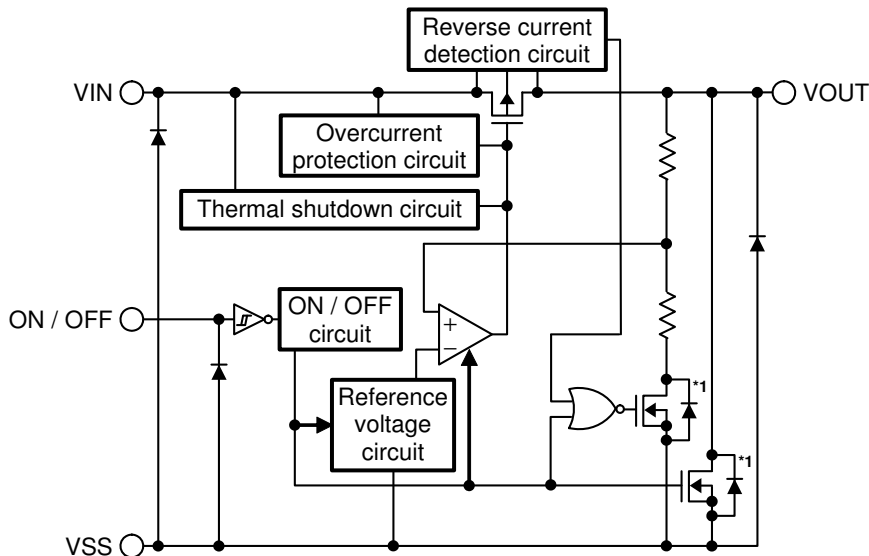

Function	Status
ON / OFF logic	Active "H"
Discharge shunt function	Available
Constant current source pull-down	Unavailable

*1. Parasitic diode

Figure 2

REVERSE CURRENT PROTECTION CMOS VOLTAGE REGULATOR S-13R1 Series

Rev.1.1_00

3. S-13R1 Series C type

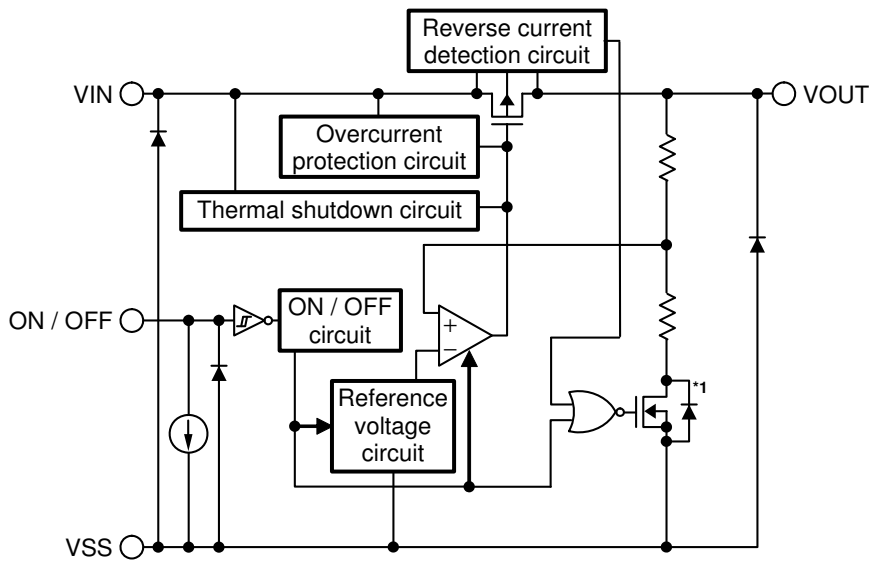

Function	Status
ON / OFF logic	Active "H"
Discharge shunt function	Unavailable
Constant current source pull-down	Available

*1. Parasitic diode

Figure 3

4. S-13R1 Series D type

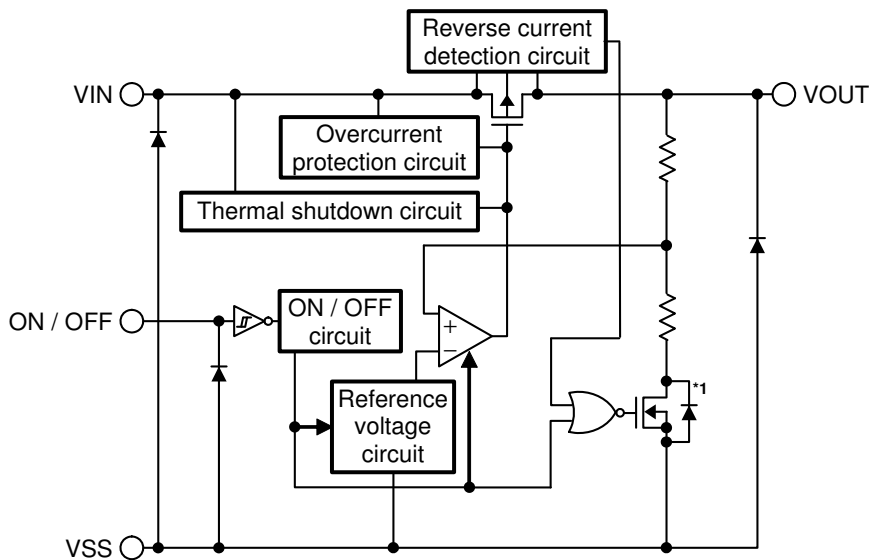

Function	Status
ON / OFF logic	Active "H"
Discharge shunt function	Unavailable
Constant current source pull-down	Unavailable

*1. Parasitic diode

Figure 4

■ **Product Name Structure**

Users can select the product type, output voltage, and package type for the S-13R1 Series. Refer to "1. **Product name**" regarding the contents of product name, "2. **Function list of product types**" regarding the product type, "3. **Packages**" regarding the package drawings, "4. **Product name lists**" regarding details of the product name.

1. Product name

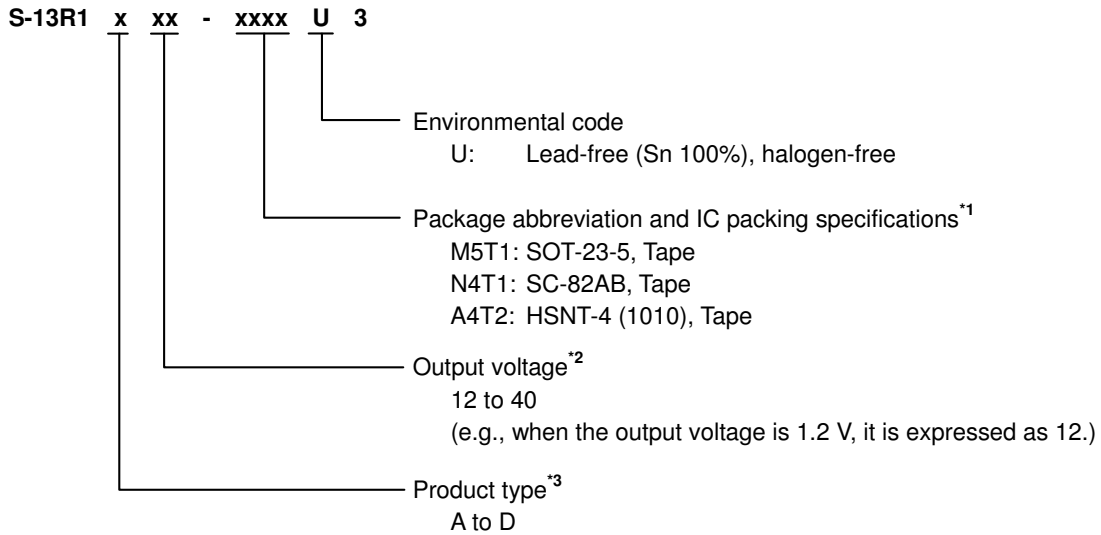

- *1. Refer to the tape drawing.
- *2. If you request the product which has 0.05 V step, contact our sales office.
- *3. Refer to "2. **Function list of product types**".

2. Function list of product types

Table 1

Product Type	ON / OFF Logic	Discharge Shunt Function	Constant Current Source Pull-down
A	Active "H"	Available	Available
B	Active "H"	Available	Unavailable
C	Active "H"	Unavailable	Available
D	Active "H"	Unavailable	Unavailable

3. Packages

Table 2 Package Drawing Codes

Package Name	Dimension	Tape	Reel	Land
SOT-23-5	MP005-A-P-SD	MP005-A-C-SD	MP005-A-R-SD	–
SC-82AB	NP004-A-P-SD	NP004-A-C-SD NP004-A-C-S1	NP004-A-R-SD	–
HSNT-4 (1010)	PL004-A-P-SD	PL004-A-C-SD	PL004-A-R-SD	PL004-A-L-SD

REVERSE CURRENT PROTECTION CMOS VOLTAGE REGULATOR

S-13R1 Series

Rev.1.1_00

4. Product name lists

4.1 S-13R1 Series A type

ON / OFF logic: Active "H"
 Discharge shunt function: Available Constant current source pull-down: Available

Table 3

Output Voltage	SOT-23-5	SC-82AB	HSNT-4 (1010)
1.2 V ± 15 mV	S-13R1A12-M5T1U3	S-13R1A12-N4T1U3	S-13R1A12-A4T2U3
1.3 V ± 15 mV	S-13R1A13-M5T1U3	S-13R1A13-N4T1U3	S-13R1A13-A4T2U3
1.4 V ± 15 mV	S-13R1A14-M5T1U3	S-13R1A14-N4T1U3	S-13R1A14-A4T2U3
1.5 V ± 1.0%	S-13R1A15-M5T1U3	S-13R1A15-N4T1U3	S-13R1A15-A4T2U3
1.6 V ± 1.0%	S-13R1A16-M5T1U3	S-13R1A16-N4T1U3	S-13R1A16-A4T2U3
1.7 V ± 1.0%	S-13R1A17-M5T1U3	S-13R1A17-N4T1U3	S-13R1A17-A4T2U3
1.8 V ± 1.0%	S-13R1A18-M5T1U3	S-13R1A18-N4T1U3	S-13R1A18-A4T2U3
1.85 V ± 1.0%	S-13R1A1J-M5T1U3	S-13R1A1J-N4T1U3	S-13R1A1J-A4T2U3
1.9 V ± 1.0%	S-13R1A19-M5T1U3	S-13R1A19-N4T1U3	S-13R1A19-A4T2U3
2.0 V ± 1.0%	S-13R1A20-M5T1U3	S-13R1A20-N4T1U3	S-13R1A20-A4T2U3
2.1 V ± 1.0%	S-13R1A21-M5T1U3	S-13R1A21-N4T1U3	S-13R1A21-A4T2U3
2.2 V ± 1.0%	S-13R1A22-M5T1U3	S-13R1A22-N4T1U3	S-13R1A22-A4T2U3
2.3 V ± 1.0%	S-13R1A23-M5T1U3	S-13R1A23-N4T1U3	S-13R1A23-A4T2U3
2.4 V ± 1.0%	S-13R1A24-M5T1U3	S-13R1A24-N4T1U3	S-13R1A24-A4T2U3
2.5 V ± 1.0%	S-13R1A25-M5T1U3	S-13R1A25-N4T1U3	S-13R1A25-A4T2U3
2.6 V ± 1.0%	S-13R1A26-M5T1U3	S-13R1A26-N4T1U3	S-13R1A26-A4T2U3
2.7 V ± 1.0%	S-13R1A27-M5T1U3	S-13R1A27-N4T1U3	S-13R1A27-A4T2U3
2.8 V ± 1.0%	S-13R1A28-M5T1U3	S-13R1A28-N4T1U3	S-13R1A28-A4T2U3
2.85 V ± 1.0%	S-13R1A2J-M5T1U3	S-13R1A2J-N4T1U3	S-13R1A2J-A4T2U3
2.9 V ± 1.0%	S-13R1A29-M5T1U3	S-13R1A29-N4T1U3	S-13R1A29-A4T2U3
3.0 V ± 1.0%	S-13R1A30-M5T1U3	S-13R1A30-N4T1U3	S-13R1A30-A4T2U3
3.1 V ± 1.0%	S-13R1A31-M5T1U3	S-13R1A31-N4T1U3	S-13R1A31-A4T2U3
3.2 V ± 1.0%	S-13R1A32-M5T1U3	S-13R1A32-N4T1U3	S-13R1A32-A4T2U3
3.3 V ± 1.0%	S-13R1A33-M5T1U3	S-13R1A33-N4T1U3	S-13R1A33-A4T2U3
3.4 V ± 1.0%	S-13R1A34-M5T1U3	S-13R1A34-N4T1U3	S-13R1A34-A4T2U3
3.5 V ± 1.0%	S-13R1A35-M5T1U3	S-13R1A35-N4T1U3	S-13R1A35-A4T2U3
3.6 V ± 1.0%	S-13R1A36-M5T1U3	S-13R1A36-N4T1U3	S-13R1A36-A4T2U3
3.7 V ± 1.0%	S-13R1A37-M5T1U3	S-13R1A37-N4T1U3	S-13R1A37-A4T2U3
3.8 V ± 1.0%	S-13R1A38-M5T1U3	S-13R1A38-N4T1U3	S-13R1A38-A4T2U3
3.9 V ± 1.0%	S-13R1A39-M5T1U3	S-13R1A39-N4T1U3	S-13R1A39-A4T2U3
4.0 V ± 1.0%	S-13R1A40-M5T1U3	S-13R1A40-N4T1U3	S-13R1A40-A4T2U3

Remark Please contact our sales office for products with specifications other than the above.

REVERSE CURRENT PROTECTION CMOS VOLTAGE REGULATOR

S-13R1 Series

Rev.1.1_00

4.2 S-13R1 Series B type

ON / OFF logic: Active "H"
 Discharge shunt function: Available Constant current source pull-down: Unavailable

Table 4

Output Voltage	SOT-23-5	SC-82AB	HSNT-4 (1010)
1.2 V ± 15 mV	S-13R1B12-M5T1U3	S-13R1B12-N4T1U3	S-13R1B12-A4T2U3
1.3 V ± 15 mV	S-13R1B13-M5T1U3	S-13R1B13-N4T1U3	S-13R1B13-A4T2U3
1.4 V ± 15 mV	S-13R1B14-M5T1U3	S-13R1B14-N4T1U3	S-13R1B14-A4T2U3
1.5 V ± 1.0%	S-13R1B15-M5T1U3	S-13R1B15-N4T1U3	S-13R1B15-A4T2U3
1.6 V ± 1.0%	S-13R1B16-M5T1U3	S-13R1B16-N4T1U3	S-13R1B16-A4T2U3
1.7 V ± 1.0%	S-13R1B17-M5T1U3	S-13R1B17-N4T1U3	S-13R1B17-A4T2U3
1.8 V ± 1.0%	S-13R1B18-M5T1U3	S-13R1B18-N4T1U3	S-13R1B18-A4T2U3
1.85 V ± 1.0%	S-13R1B1J-M5T1U3	S-13R1B1J-N4T1U3	S-13R1B1J-A4T2U3
1.9 V ± 1.0%	S-13R1B19-M5T1U3	S-13R1B19-N4T1U3	S-13R1B19-A4T2U3
2.0 V ± 1.0%	S-13R1B20-M5T1U3	S-13R1B20-N4T1U3	S-13R1B20-A4T2U3
2.1 V ± 1.0%	S-13R1B21-M5T1U3	S-13R1B21-N4T1U3	S-13R1B21-A4T2U3
2.2 V ± 1.0%	S-13R1B22-M5T1U3	S-13R1B22-N4T1U3	S-13R1B22-A4T2U3
2.3 V ± 1.0%	S-13R1B23-M5T1U3	S-13R1B23-N4T1U3	S-13R1B23-A4T2U3
2.4 V ± 1.0%	S-13R1B24-M5T1U3	S-13R1B24-N4T1U3	S-13R1B24-A4T2U3
2.5 V ± 1.0%	S-13R1B25-M5T1U3	S-13R1B25-N4T1U3	S-13R1B25-A4T2U3
2.6 V ± 1.0%	S-13R1B26-M5T1U3	S-13R1B26-N4T1U3	S-13R1B26-A4T2U3
2.7 V ± 1.0%	S-13R1B27-M5T1U3	S-13R1B27-N4T1U3	S-13R1B27-A4T2U3
2.8 V ± 1.0%	S-13R1B28-M5T1U3	S-13R1B28-N4T1U3	S-13R1B28-A4T2U3
2.85 V ± 1.0%	S-13R1B2J-M5T1U3	S-13R1B2J-N4T1U3	S-13R1B2J-A4T2U3
2.9 V ± 1.0%	S-13R1B29-M5T1U3	S-13R1B29-N4T1U3	S-13R1B29-A4T2U3
3.0 V ± 1.0%	S-13R1B30-M5T1U3	S-13R1B30-N4T1U3	S-13R1B30-A4T2U3
3.1 V ± 1.0%	S-13R1B31-M5T1U3	S-13R1B31-N4T1U3	S-13R1B31-A4T2U3
3.2 V ± 1.0%	S-13R1B32-M5T1U3	S-13R1B32-N4T1U3	S-13R1B32-A4T2U3
3.3 V ± 1.0%	S-13R1B33-M5T1U3	S-13R1B33-N4T1U3	S-13R1B33-A4T2U3
3.4 V ± 1.0%	S-13R1B34-M5T1U3	S-13R1B34-N4T1U3	S-13R1B34-A4T2U3
3.5 V ± 1.0%	S-13R1B35-M5T1U3	S-13R1B35-N4T1U3	S-13R1B35-A4T2U3
3.6 V ± 1.0%	S-13R1B36-M5T1U3	S-13R1B36-N4T1U3	S-13R1B36-A4T2U3
3.7 V ± 1.0%	S-13R1B37-M5T1U3	S-13R1B37-N4T1U3	S-13R1B37-A4T2U3
3.8 V ± 1.0%	S-13R1B38-M5T1U3	S-13R1B38-N4T1U3	S-13R1B38-A4T2U3
3.9 V ± 1.0%	S-13R1B39-M5T1U3	S-13R1B39-N4T1U3	S-13R1B39-A4T2U3
4.0 V ± 1.0%	S-13R1B40-M5T1U3	S-13R1B40-N4T1U3	S-13R1B40-A4T2U3

Remark Please contact our sales office for products with specifications other than the above.

REVERSE CURRENT PROTECTION CMOS VOLTAGE REGULATOR

S-13R1 Series

Rev.1.1_00

4.3 S-13R1 Series C type

ON / OFF logic: Active "H"
 Discharge shunt function: Unavailable Constant current source pull-down: Available

Table 5

Output Voltage	SOT-23-5	SC-82AB	HSNT-4 (1010)
1.2 V ± 15 mV	S-13R1C12-M5T1U3	S-13R1C12-N4T1U3	S-13R1C12-A4T2U3
1.3 V ± 15 mV	S-13R1C13-M5T1U3	S-13R1C13-N4T1U3	S-13R1C13-A4T2U3
1.4 V ± 15 mV	S-13R1C14-M5T1U3	S-13R1C14-N4T1U3	S-13R1C14-A4T2U3
1.5 V ± 1.0%	S-13R1C15-M5T1U3	S-13R1C15-N4T1U3	S-13R1C15-A4T2U3
1.6 V ± 1.0%	S-13R1C16-M5T1U3	S-13R1C16-N4T1U3	S-13R1C16-A4T2U3
1.7 V ± 1.0%	S-13R1C17-M5T1U3	S-13R1C17-N4T1U3	S-13R1C17-A4T2U3
1.8 V ± 1.0%	S-13R1C18-M5T1U3	S-13R1C18-N4T1U3	S-13R1C18-A4T2U3
1.85 V ± 1.0%	S-13R1C1J-M5T1U3	S-13R1C1J-N4T1U3	S-13R1C1J-A4T2U3
1.9 V ± 1.0%	S-13R1C19-M5T1U3	S-13R1C19-N4T1U3	S-13R1C19-A4T2U3
2.0 V ± 1.0%	S-13R1C20-M5T1U3	S-13R1C20-N4T1U3	S-13R1C20-A4T2U3
2.1 V ± 1.0%	S-13R1C21-M5T1U3	S-13R1C21-N4T1U3	S-13R1C21-A4T2U3
2.2 V ± 1.0%	S-13R1C22-M5T1U3	S-13R1C22-N4T1U3	S-13R1C22-A4T2U3
2.3 V ± 1.0%	S-13R1C23-M5T1U3	S-13R1C23-N4T1U3	S-13R1C23-A4T2U3
2.4 V ± 1.0%	S-13R1C24-M5T1U3	S-13R1C24-N4T1U3	S-13R1C24-A4T2U3
2.5 V ± 1.0%	S-13R1C25-M5T1U3	S-13R1C25-N4T1U3	S-13R1C25-A4T2U3
2.6 V ± 1.0%	S-13R1C26-M5T1U3	S-13R1C26-N4T1U3	S-13R1C26-A4T2U3
2.7 V ± 1.0%	S-13R1C27-M5T1U3	S-13R1C27-N4T1U3	S-13R1C27-A4T2U3
2.8 V ± 1.0%	S-13R1C28-M5T1U3	S-13R1C28-N4T1U3	S-13R1C28-A4T2U3
2.85 V ± 1.0%	S-13R1C2J-M5T1U3	S-13R1C2J-N4T1U3	S-13R1C2J-A4T2U3
2.9 V ± 1.0%	S-13R1C29-M5T1U3	S-13R1C29-N4T1U3	S-13R1C29-A4T2U3
3.0 V ± 1.0%	S-13R1C30-M5T1U3	S-13R1C30-N4T1U3	S-13R1C30-A4T2U3
3.1 V ± 1.0%	S-13R1C31-M5T1U3	S-13R1C31-N4T1U3	S-13R1C31-A4T2U3
3.2 V ± 1.0%	S-13R1C32-M5T1U3	S-13R1C32-N4T1U3	S-13R1C32-A4T2U3
3.3 V ± 1.0%	S-13R1C33-M5T1U3	S-13R1C33-N4T1U3	S-13R1C33-A4T2U3
3.4 V ± 1.0%	S-13R1C34-M5T1U3	S-13R1C34-N4T1U3	S-13R1C34-A4T2U3
3.5 V ± 1.0%	S-13R1C35-M5T1U3	S-13R1C35-N4T1U3	S-13R1C35-A4T2U3
3.6 V ± 1.0%	S-13R1C36-M5T1U3	S-13R1C36-N4T1U3	S-13R1C36-A4T2U3
3.7 V ± 1.0%	S-13R1C37-M5T1U3	S-13R1C37-N4T1U3	S-13R1C37-A4T2U3
3.8 V ± 1.0%	S-13R1C38-M5T1U3	S-13R1C38-N4T1U3	S-13R1C38-A4T2U3
3.9 V ± 1.0%	S-13R1C39-M5T1U3	S-13R1C39-N4T1U3	S-13R1C39-A4T2U3
4.0 V ± 1.0%	S-13R1C40-M5T1U3	S-13R1C40-N4T1U3	S-13R1C40-A4T2U3

Remark Please contact our sales office for products with specifications other than the above.

4.4 S-13R1 Series D type

ON / OFF logic: Active "H"
 Discharge shunt function: Unavailable Constant current source pull-down: Unavailable

Table 6

Output Voltage	SOT-23-5	SC-82AB	HSNT-4 (1010)
1.2 V ± 15 mV	S-13R1D12-M5T1U3	S-13R1D12-N4T1U3	S-13R1D12-A4T2U3
1.3 V ± 15 mV	S-13R1D13-M5T1U3	S-13R1D13-N4T1U3	S-13R1D13-A4T2U3
1.4 V ± 15 mV	S-13R1D14-M5T1U3	S-13R1D14-N4T1U3	S-13R1D14-A4T2U3
1.5 V ± 1.0%	S-13R1D15-M5T1U3	S-13R1D15-N4T1U3	S-13R1D15-A4T2U3
1.6 V ± 1.0%	S-13R1D16-M5T1U3	S-13R1D16-N4T1U3	S-13R1D16-A4T2U3
1.7 V ± 1.0%	S-13R1D17-M5T1U3	S-13R1D17-N4T1U3	S-13R1D17-A4T2U3
1.8 V ± 1.0%	S-13R1D18-M5T1U3	S-13R1D18-N4T1U3	S-13R1D18-A4T2U3
1.85 V ± 1.0%	S-13R1D1J-M5T1U3	S-13R1D1J-N4T1U3	S-13R1D1J-A4T2U3
1.9 V ± 1.0%	S-13R1D19-M5T1U3	S-13R1D19-N4T1U3	S-13R1D19-A4T2U3
2.0 V ± 1.0%	S-13R1D20-M5T1U3	S-13R1D20-N4T1U3	S-13R1D20-A4T2U3
2.1 V ± 1.0%	S-13R1D21-M5T1U3	S-13R1D21-N4T1U3	S-13R1D21-A4T2U3
2.2 V ± 1.0%	S-13R1D22-M5T1U3	S-13R1D22-N4T1U3	S-13R1D22-A4T2U3
2.3 V ± 1.0%	S-13R1D23-M5T1U3	S-13R1D23-N4T1U3	S-13R1D23-A4T2U3
2.4 V ± 1.0%	S-13R1D24-M5T1U3	S-13R1D24-N4T1U3	S-13R1D24-A4T2U3
2.5 V ± 1.0%	S-13R1D25-M5T1U3	S-13R1D25-N4T1U3	S-13R1D25-A4T2U3
2.6 V ± 1.0%	S-13R1D26-M5T1U3	S-13R1D26-N4T1U3	S-13R1D26-A4T2U3
2.7 V ± 1.0%	S-13R1D27-M5T1U3	S-13R1D27-N4T1U3	S-13R1D27-A4T2U3
2.8 V ± 1.0%	S-13R1D28-M5T1U3	S-13R1D28-N4T1U3	S-13R1D28-A4T2U3
2.85 V ± 1.0%	S-13R1D2J-M5T1U3	S-13R1D2J-N4T1U3	S-13R1D2J-A4T2U3
2.9 V ± 1.0%	S-13R1D29-M5T1U3	S-13R1D29-N4T1U3	S-13R1D29-A4T2U3
3.0 V ± 1.0%	S-13R1D30-M5T1U3	S-13R1D30-N4T1U3	S-13R1D30-A4T2U3
3.1 V ± 1.0%	S-13R1D31-M5T1U3	S-13R1D31-N4T1U3	S-13R1D31-A4T2U3
3.2 V ± 1.0%	S-13R1D32-M5T1U3	S-13R1D32-N4T1U3	S-13R1D32-A4T2U3
3.3 V ± 1.0%	S-13R1D33-M5T1U3	S-13R1D33-N4T1U3	S-13R1D33-A4T2U3
3.4 V ± 1.0%	S-13R1D34-M5T1U3	S-13R1D34-N4T1U3	S-13R1D34-A4T2U3
3.5 V ± 1.0%	S-13R1D35-M5T1U3	S-13R1D35-N4T1U3	S-13R1D35-A4T2U3
3.6 V ± 1.0%	S-13R1D36-M5T1U3	S-13R1D36-N4T1U3	S-13R1D36-A4T2U3
3.7 V ± 1.0%	S-13R1D37-M5T1U3	S-13R1D37-N4T1U3	S-13R1D37-A4T2U3
3.8 V ± 1.0%	S-13R1D38-M5T1U3	S-13R1D38-N4T1U3	S-13R1D38-A4T2U3
3.9 V ± 1.0%	S-13R1D39-M5T1U3	S-13R1D39-N4T1U3	S-13R1D39-A4T2U3
4.0 V ± 1.0%	S-13R1D40-M5T1U3	S-13R1D40-N4T1U3	S-13R1D40-A4T2U3

Remark Please contact our sales office for products with specifications other than the above.

■ **Pin Configurations**

1. SOT-23-5

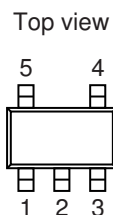

Figure 5

Table 7

Pin No.	Symbol	Description
1	VIN	Input voltage pin
2	VSS	GND pin
3	ON / OFF	ON / OFF pin
4	NC*1	No connection
5	VOUT	Output voltage pin

*1. The NC pin is electrically open.
 The NC pin can be connected to the VIN pin or the VSS pin.

2. SC-82AB

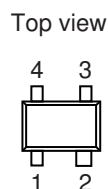

Figure 6

Table 8

Pin No.	Symbol	Description
1	ON / OFF	ON / OFF pin
2	VSS	GND pin
3	VOUT	Output voltage pin
4	VIN	Input voltage pin

3. HSNT-4 (1010)

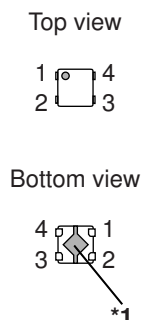

Table 9

Pin No.	Symbol	Description
1	VOUT	Output voltage pin
2	VSS	GND pin
3	ON / OFF	ON / OFF pin
4	VIN	Input voltage pin

*1. Connect the heatsink of backside at shadowed area to the board, and set electric potential open or GND. However, do not use it as the function of electrode.

Figure 7

■ **Absolute Maximum Ratings**

Table 10

(Ta = +25°C unless otherwise specified)

Item	Symbol	Absolute Maximum Rating	Unit	
Input voltage	V _{IN}	V _{SS} - 0.3 to V _{SS} + 6.0	V	
	V _{ON/OFF}	V _{SS} - 0.3 to V _{SS} + 6.0	V	
Output voltage	V _{OUT}	V _{SS} - 0.3 to V _{SS} + 6.0	V	
Output current	I _{OUT}	200	mA	
Power dissipation	P _D	SOT-23-5	600 ^{*1}	mW
		SC-82AB	400 ^{*1}	mW
		HSNT-4 (1010)	340 ^{*1}	mW
Operation ambient temperature	T _{opr}	-40 to +85	°C	
Storage temperature	T _{stg}	-40 to +125	°C	

*1. When mounted on board

[Mounted board]

- (1) Board size: 114.3 mm × 76.2 mm × t1.6 mm
- (2) Name: JEDEC STANDARD51-7

Caution The absolute maximum ratings are rated values exceeding which the product could suffer physical damage. These values must therefore not be exceeded under any conditions.

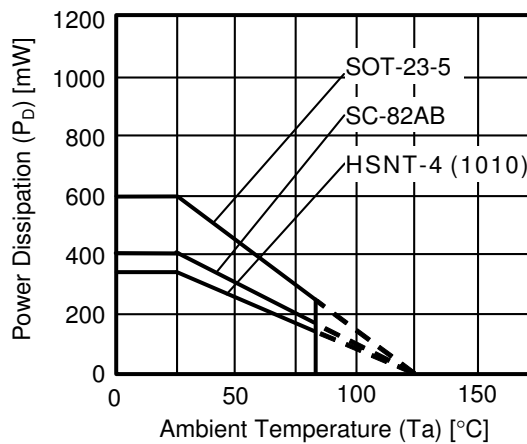

Figure 8 Power Dissipation of Package (When Mounted on Board)

Power Dissipation of HSNT-4 (1010) (Reference)

Power dissipation of package differs depending on the mounting conditions.
 Consider the power dissipation characteristics under the following conditions as reference.

[Mounted board]

- (1) Board size: 40 mm × 40 mm × t0.8 mm
- (2) Board material: Glass epoxy resin (four layers)
- (3) Wiring ratio: 50%
- (4) Test conditions: When mounted on board (wind speed: 0 m/s)
- (5) Land pattern: Refer to the recommended land pattern (drawing code: PL004-A-L-SD)

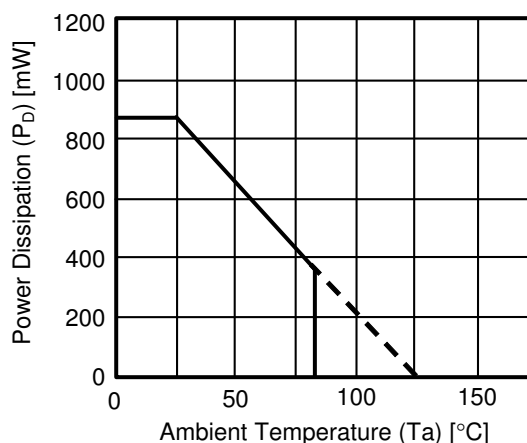

Figure 9 Power Dissipation of Package (When Mounted on Board)

Table 11

Condition	Power Dissipation (Reference)	Thermal Resistance Value (θ_{j-a})
HSNT-4 (1010) (When mounted on board)	870 mW	115°C/W

■ Electrical Characteristics

Table 12 (1 / 2)

(Ta = +25°C unless otherwise specified)

Item	Symbol	Condition	Min.	Typ.	Max.	Unit	Test Circuit	
Output voltage*1	V _{OUT(E)}	V _{IN} = V _{OUT(S)} + 1.0 V, I _{OUT} = 30 mA	1.2 V ≤ V _{OUT(S)} < 1.5 V	V _{OUT(S)} − 0.015	V _{OUT(S)}	V _{OUT(S)} + 0.015	V	1
			1.5 V ≤ V _{OUT(S)} ≤ 4.0 V	V _{OUT(S)} × 0.99	V _{OUT(S)}	V _{OUT(S)} × 1.01	V	1
Output current*2	I _{OUT}	V _{IN} ≥ V _{OUT(S)} + 1.0 V	150*5	–	–	mA	3	
Dropout voltage*3	V _{drop}	I _{OUT} = 100 mA	1.2 V ≤ V _{OUT(S)} < 1.3 V	0.80	0.84	0.88	V	1
			1.3 V ≤ V _{OUT(S)} < 1.4 V	–	0.74	0.78	V	1
			1.4 V ≤ V _{OUT(S)} < 1.5 V	–	0.64	0.68	V	1
			1.5 V ≤ V _{OUT(S)} < 1.6 V	–	0.54	0.58	V	1
			1.6 V ≤ V _{OUT(S)} < 1.7 V	–	0.44	0.48	V	1
			1.7 V ≤ V _{OUT(S)} < 1.8 V	–	0.34	0.38	V	1
			1.8 V ≤ V _{OUT(S)} < 2.0 V	–	0.24	0.28	V	1
			2.0 V ≤ V _{OUT(S)} < 2.8 V	–	0.19	0.28	V	1
2.8 V ≤ V _{OUT(S)} < 3.0 V	–	0.17	0.23	V	1			
3.0 V ≤ V _{OUT(S)} ≤ 4.0 V	–	0.15	0.23	V	1			
Line regulation	$\frac{\Delta V_{OUT1}}{\Delta V_{IN} \cdot V_{OUT}}$	2.0 V ≤ V _{IN} ≤ 5.5 V, I _{OUT} = 30 mA	1.2 V ≤ V _{OUT(S)} < 1.5 V	–	0.05	0.2	%/V	1
		V _{OUT(S)} + 0.5 V ≤ V _{IN} ≤ 5.5 V, I _{OUT} = 30 mA	1.5 V ≤ V _{OUT(S)} ≤ 4.0 V	–	0.05	0.2	%/V	1
Load regulation	ΔV_{OUT2}	V _{IN} = V _{OUT(S)} + 1.0 V, 10 μA ≤ I _{OUT} ≤ 100 mA	–	25	40	mV	1	
Output voltage temperature coefficient*4	$\frac{\Delta V_{OUT}}{\Delta Ta \cdot V_{OUT}}$	V _{IN} = V _{OUT(S)} + 1.0 V, I _{OUT} = 100 mA, −40°C ≤ Ta ≤ +85°C	–	±100	–	ppm/°C	1	
Current consumption during operation	I _{SS1}	V _{IN} = V _{OUT(S)} + 1.0 V, ON / OFF pin = ON, no load	–	5.0	9.0	μA	2	
Reverse current	I _{REV}	0 V ≤ V _{IN} < V _{OUT}	–	–	0.09	μA	6	
Current consumption during power-off	I _{SS2}	V _{IN} = V _{OUT(S)} + 1.0 V, ON / OFF pin = OFF, no load	–	0.1	1.0	μA	2	
Input voltage	V _{IN}	–	2.0	–	5.5	V	–	
ON / OFF pin input voltage "H"	V _{SH}	V _{IN} = V _{OUT(S)} + 1.0 V, R _L = 1.0 kΩ, determined by V _{OUT} output level	1.0	–	–	V	4	
ON / OFF pin input voltage "L"	V _{SL}	V _{IN} = V _{OUT(S)} + 1.0 V, R _L = 1.0 kΩ, determined by V _{OUT} output level	–	–	0.3	V	4	
ON / OFF pin input current "H"	I _{SH}	V _{IN} = 5.5 V, V _{ON / OFF} = 5.5 V	B / D type (without constant current source pull-down)	−0.1	–	0.1	μA	4
			A / C type (with constant current source pull-down)	0.05	0.10	0.20	μA	4
ON / OFF pin input current "L"	I _{SL}	V _{IN} = V _{OUT(S)} + 1.0 V, V _{ON / OFF} = 0 V	−0.1	–	0.1	μA	4	
Ripple rejection	RR	V _{IN} = V _{OUT(S)} + 1.0 V, f = 1.0 kHz, ΔV _{rip} = 0.5 Vrms, I _{OUT} = 100 mA	–	70	–	dB	5	
Limit current	I _{LIM}	V _{IN} = V _{OUT(S)} + 1.0 V, ON / OFF pin = ON	200	250	400	mA	3	
Short-circuit current	I _{short}	V _{IN} = V _{OUT(S)} + 1.0 V, ON / OFF pin = ON, V _{OUT} = 0 V	–	30	–	mA	3	
Thermal shutdown detection temperature	T _{SD}	Junction temperature	–	150	–	°C	–	
Thermal shutdown release temperature	T _{SR}	Junction temperature	–	120	–	°C	–	

REVERSE CURRENT PROTECTION CMOS VOLTAGE REGULATOR S-13R1 Series

Rev.1.1_00

Table 12 (2 / 2)

(Ta = +25°C unless otherwise specified)

Item	Symbol	Condition	Min.	Typ.	Max.	Unit	Test Circuit
"L" output Nch ON resistance	R _{LOW}	V _{IN} = 5.5 V, V _{OUT} = 0.1 V A / B type (with discharge shunt function)	–	35	–	Ω	3
Reverse current protection mode detection voltage	V _{REVD}	0 V ≤ V _{IN} ≤ 5.5 V, V _{OUT} ≥ 0.5 V, V _{REVD} = V _{IN} – V _{OUT}	20	45	100	mV	6
Reverse current protection mode release voltage	V _{REVR}	0 V ≤ V _{IN} ≤ 5.5 V, V _{OUT} ≥ 0.5 V, V _{REVR} = V _{IN} – V _{OUT}	50	75	120	mV	6

*1. V_{OUT(S)}: Set output voltage

V_{OUT(E)}: Actual output voltage

Output voltage when fixing I_{OUT} (= 30 mA) and inputting V_{OUT(S)} + 1.0 V

*2. The output current at which the output voltage becomes 95% of V_{OUT(E)} after gradually increasing the output current.

*3. V_{drop} = V_{IN1} – (V_{OUT3} × 0.98)

V_{OUT3} is the output voltage when V_{IN} = V_{OUT(S)} + 1.0 V and I_{OUT} = 100 mA.

V_{IN1} is the input voltage at which the output voltage becomes 98% of V_{OUT3} after gradually decreasing the input voltage.

*4. A change in the temperature of the output voltage [mV/°C] is calculated using the following equation.

$$\frac{\Delta V_{OUT}}{\Delta T_a} \text{ [mV/°C]}^*1 = V_{OUT(S)} \text{ [V]}^*2 \times \frac{\Delta V_{OUT}}{\Delta T_a \cdot V_{OUT}} \text{ [ppm/°C]}^*3 \div 1000$$

*1. Change in temperature of output voltage

*2. Set output voltage

*3. Output voltage temperature coefficient

*5. The output current can be at least this value.

Due to restrictions on the package power dissipation, this value may not be satisfied. Attention should be paid to the power dissipation of the package when the output current is large.

This specification is guaranteed by design.

■ **Test Circuits**

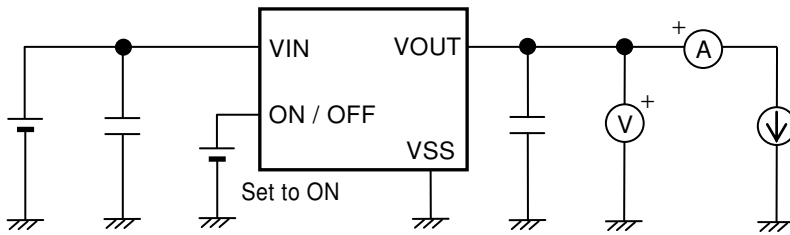

Figure 10 Test Circuit 1

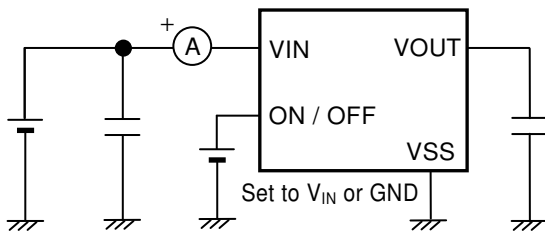

Figure 11 Test Circuit 2

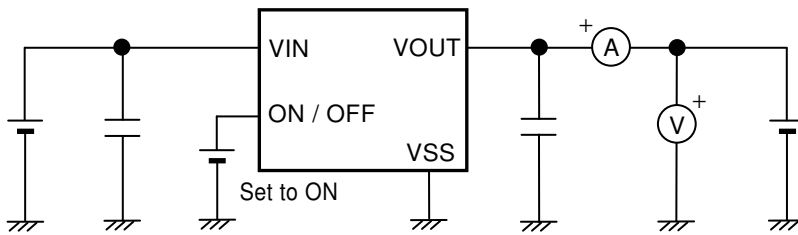

Figure 12 Test Circuit 3

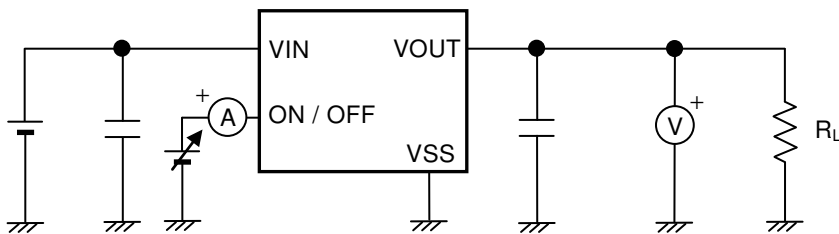

Figure 13 Test Circuit 4

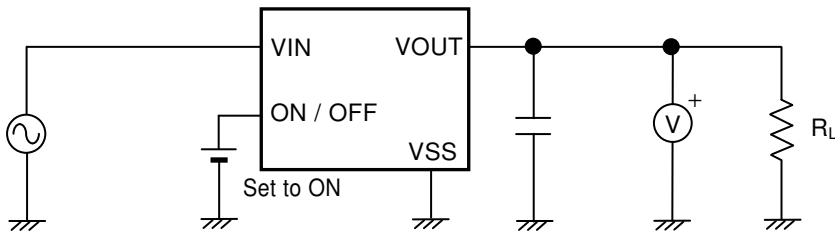

Figure 14 Test Circuit 5

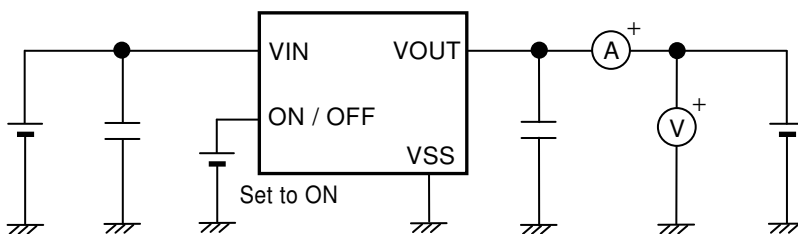
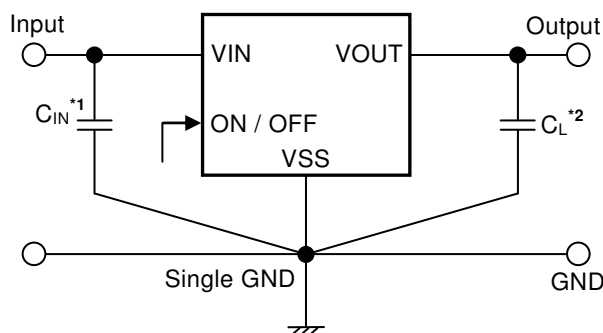

Figure 15 Test Circuit 6

■ **Standard Circuit**



- *1. C_{IN} is a capacitor for stabilizing the input.
- *2. A ceramic capacitor of 1.0 μF or more can be used as C_L .

Figure 16

Caution The above connection diagram and constant will not guarantee successful operation. Perform thorough evaluation using the actual application to set the constant.

■ **Condition of Application**

Input capacitor (C_{IN}): 1.0 μF or more
 Output capacitor (C_L): 1.0 μF or more

Caution Generally a series regulator may cause oscillation, depending on the selection of external parts. Confirm that no oscillation occurs in the application for which the above capacitors are used.

■ **Selection of Input and Output Capacitors (C_{IN} , C_L)**

The S-13R1 Series requires an output capacitor between the VOUT pin and the VSS pin for phase compensation. Operation is stabilized by a ceramic capacitor with an output capacitance of 1.0 μF or more over the entire temperature range. When using an OS capacitor, a tantalum capacitor, or an aluminum electrolytic capacitor, the capacitance must be 1.0 μF or more.

The value of the output overshoot or undershoot transient response varies depending on the value of the output capacitor. The required capacitance of the input capacitor differs depending on the application.

The recommended capacitance for an application is $C_{IN} \geq 1.0 \mu\text{F}$, $C_L \geq 1.0 \mu\text{F}$; however, when selecting the output capacitor, perform sufficient evaluation, including evaluation of temperature characteristics, on the actual device.

■ Explanation of Terms

1. Low dropout voltage regulator

This voltage regulator has the low dropout voltage due to its built-in low on-resistance transistor.

2. Output voltage (V_{OUT})

The accuracy of the output voltage is ensured at $\pm 1.0\%$ or $\pm 15 \text{ mV}^{\ast 1}$ under the specified conditions of fixed input voltage ^{$\ast 2$} , fixed output current, and fixed temperature.

$\ast 1$. When $V_{OUT(S)} < 1.5 \text{ V}$: $\pm 15 \text{ mV}$, when $V_{OUT(S)} \geq 1.5 \text{ V}$: $\pm 1.0\%$

$\ast 2$. Differs depending on the product.

Caution If the above conditions change, the output voltage value may vary and exceed the accuracy range of the output voltage. Refer to "■ Electrical Characteristics" and "■ Characteristics (Typical Data)" for details.

3. Line regulation $\left(\frac{\Delta V_{OUT1}}{\Delta V_{IN} \cdot V_{OUT}} \right)$

Indicates the dependency of the output voltage on the input voltage. That is, the values show how much the output voltage changes due to a change in the input voltage with the output current remaining unchanged.

4. Load regulation (ΔV_{OUT2})

Indicates the dependency of the output voltage on the output current. That is, the values show how much the output voltage changes due to a change in the output current with the input voltage remaining unchanged.

5. Dropout voltage (V_{drop})

Indicates the difference between input voltage V_{IN1} and the output voltage when; decreasing input voltage V_{IN} gradually until the output voltage has dropped out to the value of 98% of output voltage V_{OUT3} , which is at $V_{IN} = V_{OUT(S)} + 1.0 \text{ V}$.

$$V_{drop} = V_{IN1} - (V_{OUT3} \times 0.98)$$

6. Output voltage temperature coefficient $\left(\frac{\Delta V_{OUT}}{\Delta T_a \cdot V_{OUT}}\right)$

The shaded area in **Figure 17** is the range where V_{OUT} varies in the operation temperature range when the output voltage temperature coefficient is ± 100 ppm/ $^{\circ}$ C.

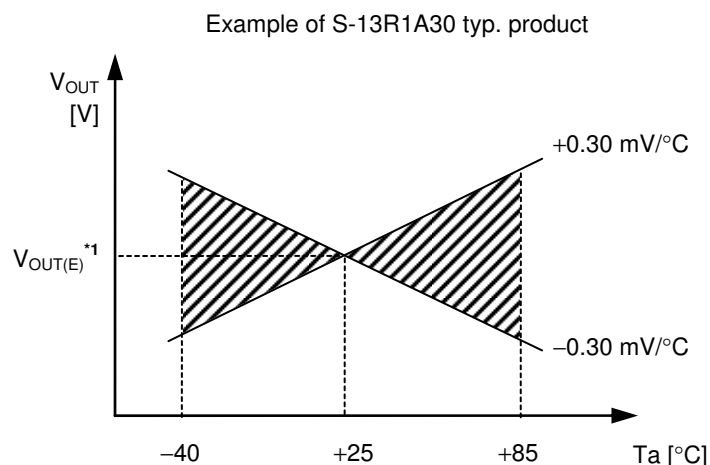

*1. $V_{OUT(E)}$ is the value of the output voltage measured at $T_a = +25^{\circ}$ C.

Figure 17

A change in the temperature of the output voltage [mV/ $^{\circ}$ C] is calculated using the following equation.

$$\frac{\Delta V_{OUT}}{\Delta T_a} \text{ [mV/}^{\circ}\text{C]}^{*1} = V_{OUT(S)} \text{ [V]}^{*2} \times \frac{\Delta V_{OUT}}{\Delta T_a \cdot V_{OUT}} \text{ [ppm/}^{\circ}\text{C]}^{*3} \div 1000$$

- *1. Change in temperature of output voltage
- *2. Set output voltage
- *3. Output voltage temperature coefficient

■ Operation

1. Basic operation

Figure 18 shows the block diagram of the S-13R1 Series.

The error amplifier compares the reference voltage (V_{ref}) with feedback voltage (V_{fb}), which is the output voltage resistance-divided by feedback resistors (R_s , R_f). It supplies the gate voltage necessary to maintain the constant output voltage which is not influenced by the input voltage and temperature change, to the output transistor.

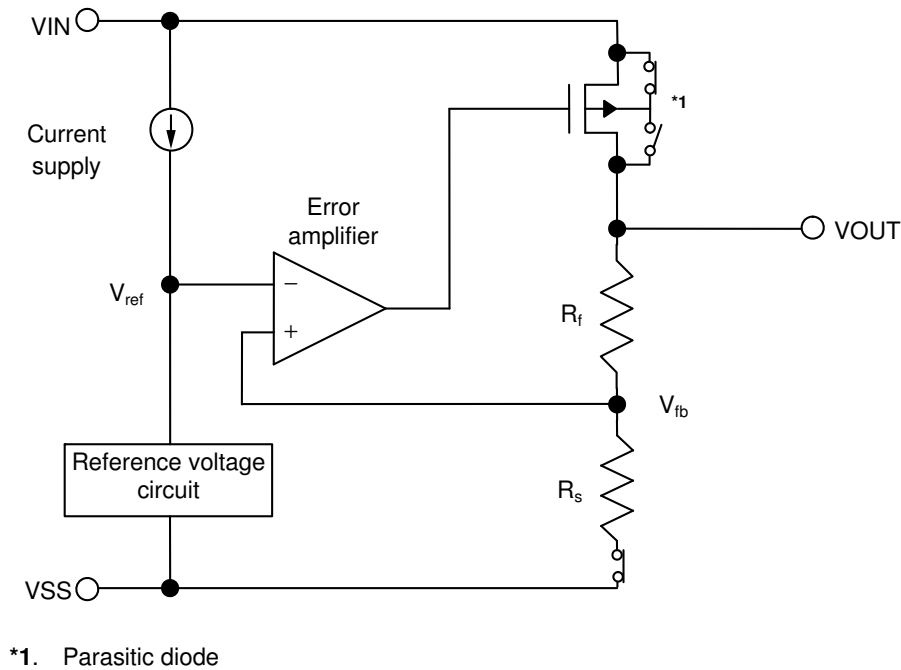

Figure 18

2. Output transistor

In the S-13R1 Series, a low on-resistance P-channel MOS FET is used as the output transistor.

Since there exists a parasitic diode between the VIN pin and the VOUT pin, the reverse current arises when potential of V_{OUT} becomes higher than V_{IN} . However, the reverse current detection circuit prevents the current from flowing from the VOUT pin in the S-13R1 Series. Therefore, the IC is not damaged even when the potential of V_{OUT} becomes higher than V_{IN} .

3. ON / OFF pin

This pin starts and stops the regulator.

When the ON / OFF pin is set to OFF level, the entire internal circuit stops operating, and the built-in P-channel MOS FET output transistor between the VIN pin and the VOUT pin is turned off, reducing current consumption significantly.

Note that the current consumption increases when a voltage of 0.3 V to 1.0 V is applied to the ON / OFF pin. The ON / OFF pin is configured as shown in **Figure 19** and **Figure 20**.

3.1 S-13R1 Series A / C type

The ON / OFF pin is internally pulled down to the VSS pin in the floating status, so the VOUT pin is set to the V_{SS} level.

3.2 S-13R1 Series B / D type

The ON / OFF pin is not internally pulled down to the VSS pin, so do not use this pin in the floating status. When not using the ON / OFF pin, connect the pin to the VIN pin.

Table 13

Product Type	ON / OFF Pin	Internal Circuit	VOUT Pin Voltage	Current Consumption
A / B / C / D	"H": ON	Operate	Set value	I _{SS1} *1
A / B	"L": OFF	Stop	V _{SS} level	I _{SS2}
C / D	"L": OFF	Stop	High-Z ≡ V _{SS} level	I _{SS2}

*1. Note that the IC's current consumption increases as much as current flows into the constant current of 0.1 μA typ. when the ON / OFF pin is connected to the VIN pin and the S-13R1 Series A / C type is operating (refer to **Figure 19**).

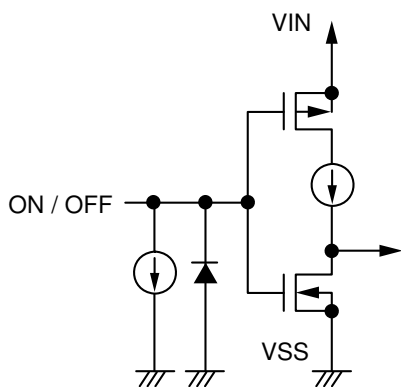

Figure 19 S-13R1 Series A / C type

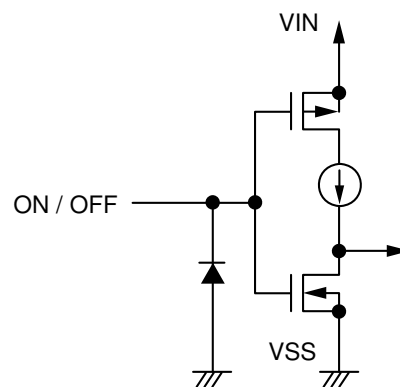

Figure 20 S-13R1 Series B / D type

4. Discharge shunt function (S-13R1 Series A / B type)

The S-13R1 Series A / B type has a built-in discharge shunt circuit to discharge the output capacitance. The output capacitance is discharged as follows so that the VOUT pin reaches the V_{SS} level.

- (1) The ON / OFF pin is set to OFF level.
- (2) The output transistor is turned off.
- (3) The discharge shunt circuit is turned on.
- (4) The output capacitor discharges.

Since the S-13R1 Series C / D type does not have a discharge shunt circuit, the VOUT pin is not discharged. The S-13R1 Series A / B type allows the VOUT pin to reach the V_{SS} level rapidly due to the discharge shunt circuit.

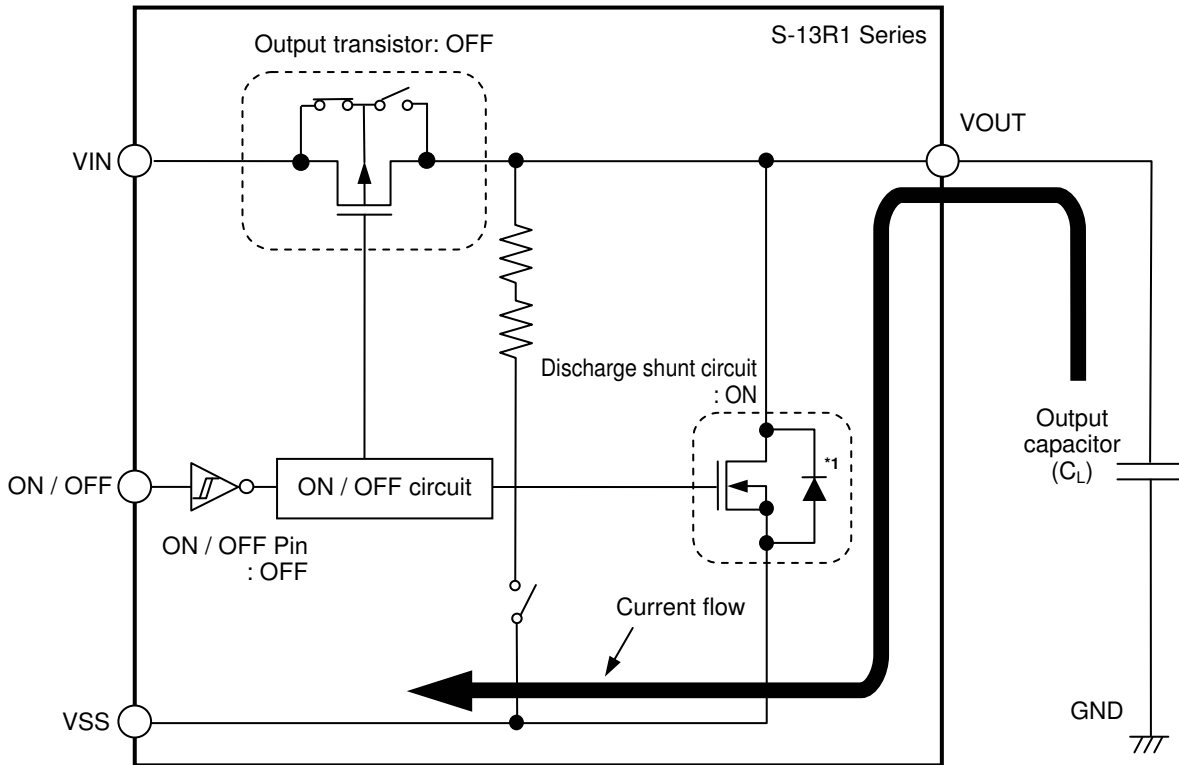

*1. Parasitic diode

Figure 21

5. Constant current source pull-down (S-13R1 Series A / C type)

The ON / OFF pin is internally pulled down to the V_{SS} pin in the floating status, so the V_{OUT} pin is set to the V_{SS} level.

Note that the IC's current consumption increases as much as current flows into the constant current of 0.1 μA typ. when the ON / OFF pin is connected to the VIN pin and the S-13R1 Series A / C type is operating.

6. Overcurrent protection circuit

The S-13R1 Series has an overcurrent protection circuit having the characteristics shown in "1. Output voltage vs. Output current (When load current increases) (Ta = +25°C)" in "■ Characteristics (Typical Data)", in order to protect the output transistor against an excessive output current and short circuiting between the VOUT pin and the VSS pin. The current (I_{short}) when the output pin is short-circuited is internally set at approx. 30 mA typ., and the normal value is restored for the output voltage, if releasing a short circuit once.

Caution This overcurrent protection circuit does not work as for thermal protection. If this IC long keeps short circuiting inside, pay attention to the conditions of input voltage and load current so that, under the usage conditions including short circuit, the loss of the IC will not exceed power dissipation of the package.

7. Thermal shutdown circuit

The S-13R1 Series has a thermal shutdown circuit to protect the device from damage due to overheat. When the junction temperature rises to 150°C typ., the thermal shutdown circuit operates to stop regulating. When the junction temperature drops to 120°C typ., the thermal shutdown circuit is released to restart regulating.

Due to self-heating of the S-13R1 Series, if the thermal shutdown circuit starts operating, it stops regulating so that the output voltage drops. When regulation stops, the S-13R1 Series does not itself generate heat and the IC's temperature drops. When the temperature drops, the thermal shutdown circuit is released to restart regulating, thus the S-13R1 Series generates heat again. Repeating this procedure makes the waveform of the output voltage into a pulse-like form. Stop or restart of regulation continues unless decreasing either or both of the input voltage and the output current in order to reduce the internal power consumption, or decreasing the ambient temperature.

Table 14

Thermal Shutdown Circuit	VOUT Pin Voltage
Operate: 150°C typ.*1	V _{SS} level
Release: 120°C typ.*1	Set value

*1. Junction temperature

8. Reverse current protection function

8.1 Detection and release of reverse current protection mode

The reverse current protection function compares values of the VIN pin voltage (VIN) and the VOUT pin voltage (VOUT), and prevents the current from flowing to the VIN pin and the VSS pin from the VOUT pin. Also, in the S-13R1 Series A / B type, the current flows from the VOUT pin to the VSS pin due to a discharge shunt circuit. During the reverse current protection mode, the connection direction of parasitic diode of the output transistor is switched by the reverse current protection circuit, and the feedback resistors (RS, RF) and the VSS pin are disconnected.

The reverse current is prevented by switching the reverse current protection mode before VIN becomes lower than VOUT.

As shown in **Figure 24**, in the case of $V_{IN} - V_{OUT} > V_{REVD}$, the S-13R1 Series is in normal operation mode. The reverse current protection mode is detected when $V_{IN} - V_{OUT} \leq V_{REVD}$.

In order to insure the stable operation, there is also a hysteresis for detection and release of the reverse current protection mode. Therefore, the reverse current protection mode is released when $V_{IN} - V_{OUT} \geq V_{REVR}$. The reverse current detection circuit operates at $0\text{ V} \leq V_{IN} \leq 5.5\text{ V}$ and $V_{OUT} \geq 0.5\text{ V}$.

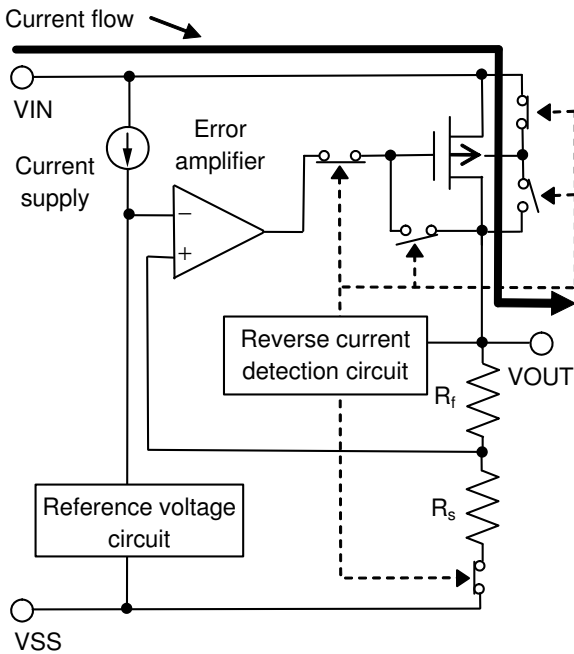

Figure 22 Normal Operation Mode

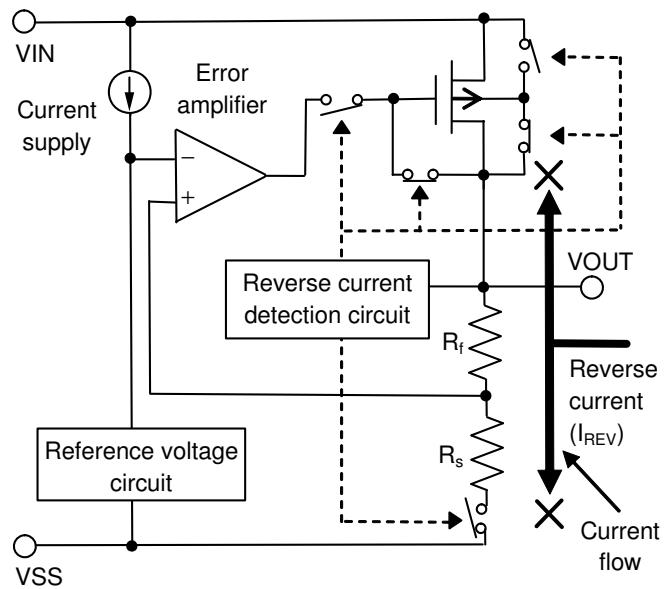

Figure 23 Reverse Current Protection Mode

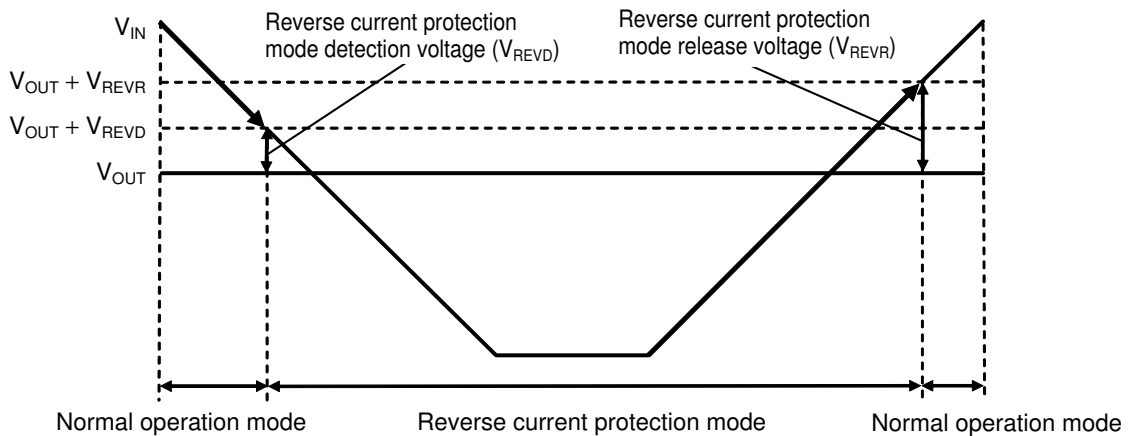

Figure 24

8.2 Power-on (ON / OFF pin = ON)

At power-on, the reverse current protection mode and the normal operation mode may be repeated during the time period of $V_{IN} - V_{OUT} \leq V_{REVD}$.

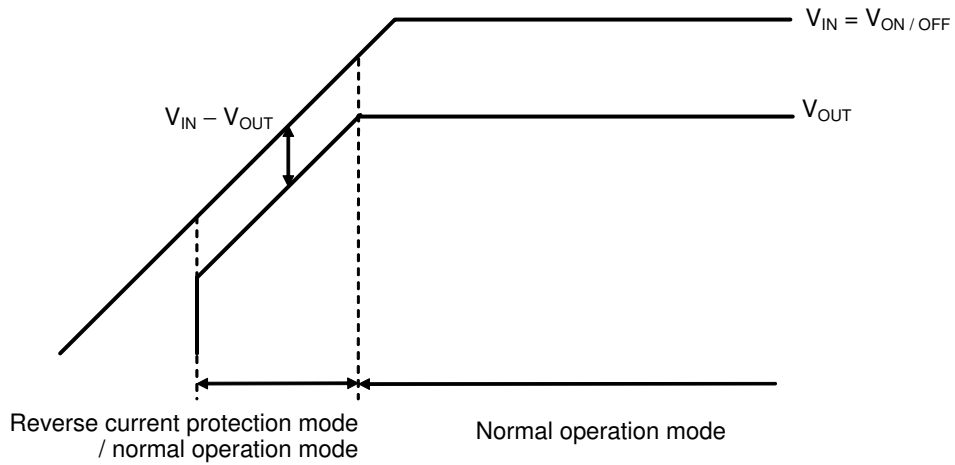

Figure 25

■ Precautions

- Wiring patterns for the VIN pin, the VOUT pin and GND should be designed so that the impedance is low. When mounting an output capacitor between the VOUT pin and the VSS pin (C_L) and the capacitor for stabilizing the input between the VIN pin and the VSS pin (C_{IN}), the distance from the capacitors to these pins should be as short as possible.
- Note that generally the output voltage may increase when a series regulator is used at low load current (10 μ A or less).
If the S-13R1 Series is used at low load current (several hundred nA), the output voltage may increase due to the leakage current from an output driver at high temperature, and the reverse current protection mode may not be released. Perform sufficient evaluation with the actual device in use.
- Note that the output voltage may increase due to the leakage current from an output driver even if the ON / OFF pin is at OFF level when a series regulator is used at high temperature.
- Generally a series regulator may cause oscillation, depending on the selection of external parts. The following conditions are recommended for the S-13R1 Series. However, be sure to perform sufficient evaluation under the actual usage conditions for selection, including evaluation of temperature characteristics. Refer to "5. Example of equivalent series resistance vs. Output current characteristics ($T_a = +25^\circ\text{C}$)" in "■ Reference Data" for the equivalent series resistance (R_{ESR}) of the output capacitor.

Input capacitor (C_{IN}): 1.0 μ F or more

Output capacitor (C_L): 1.0 μ F or more

- The voltage regulator may oscillate when the impedance of the power supply is high and the input capacitance is small or an input capacitor is not connected.
- If the output capacitance is small, power supply's fluctuation and the characteristics of load fluctuation become worse. Sufficiently evaluate the output voltage's fluctuation with the actual device.
- Overshoot may occur in the output voltage momentarily if the voltage is rapidly raised at power-on or when the power supply fluctuates. Sufficiently evaluate the output voltage at power-on with the actual device.
- The application conditions for the input voltage, the output voltage, and the load current should not exceed the package power dissipation.
- Do not apply an electrostatic discharge to this IC that exceeds the performance ratings of the built-in electrostatic protection circuit.
- In determining the output current, attention should be paid to the output current value specified in **Table 12** in "■ Electrical Characteristics" and footnote *5 of the table.
- SII claims no responsibility for any disputes arising out of or in connection with any infringement by products including this IC of patents owned by a third party.

■ Characteristics (Typical Data)

1. Output voltage vs. Output current (When load current increases) (Ta = +25°C)

1.1 $V_{OUT(S)} = 1.2\text{ V}$

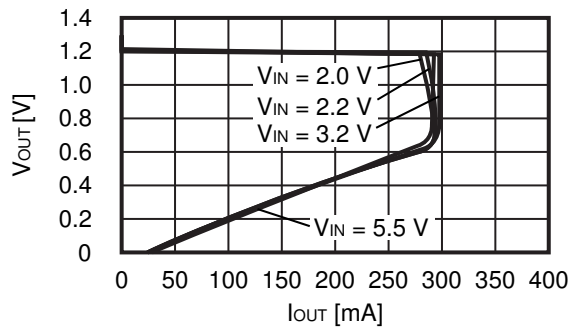

1.2 $V_{OUT(S)} = 3.0\text{ V}$

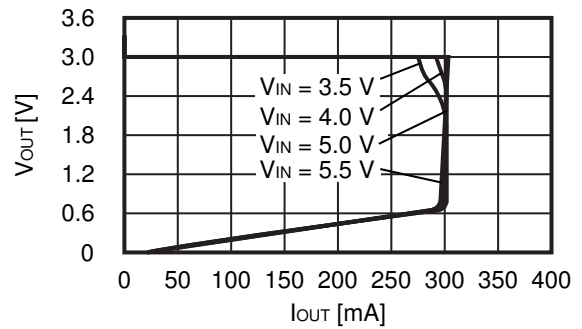

1.3 $V_{OUT(S)} = 4.0\text{ V}$

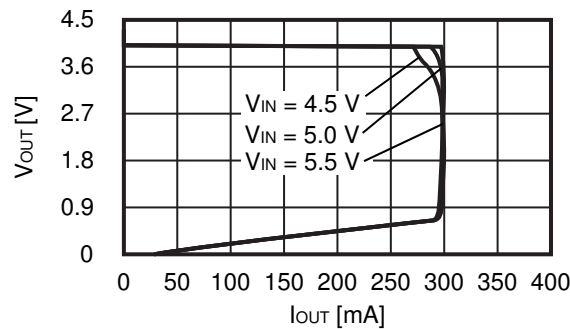

Remark In determining the output current, attention should be paid to the following.

1. The minimum output current value and footnote *5 of Table 12 in "■ Electrical Characteristics"
2. The package power dissipation

2. Output voltage vs. Input voltage (Ta = +25°C)

2.1 $V_{OUT(S)} = 1.2\text{ V}$

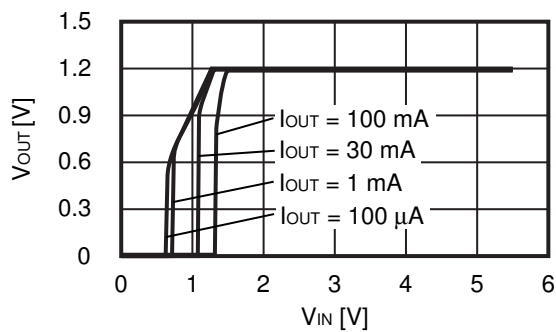

2.2 $V_{OUT(S)} = 3.0\text{ V}$

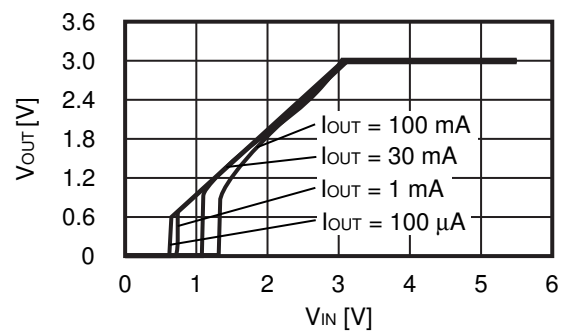

2.3 $V_{OUT(S)} = 4.0\text{ V}$

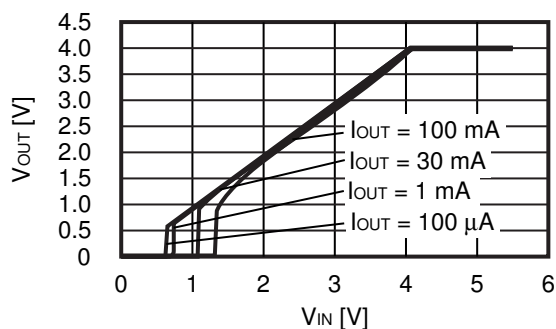

3. Dropout voltage vs. Output current

3.1 $V_{OUT(S)} = 1.2\text{ V}$

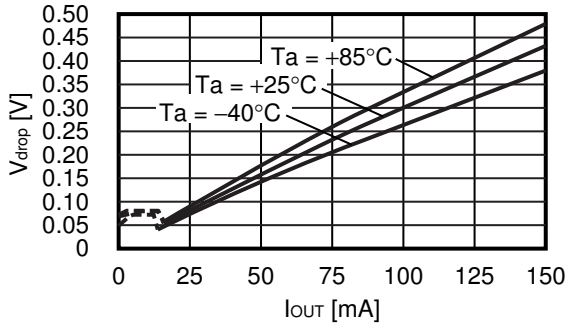

3.2 $V_{OUT(S)} = 3.0\text{ V}$

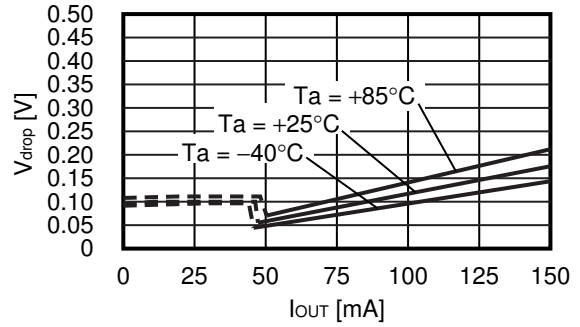

3.3 $V_{OUT(S)} = 4.0\text{ V}$

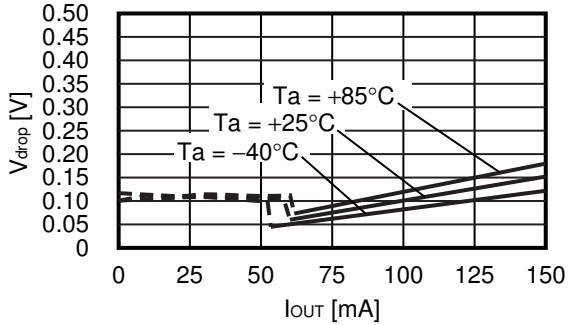

4. Dropout voltage vs. Set output voltage

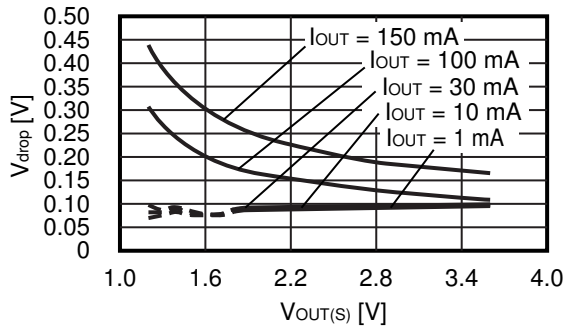

Remark In dashed line areas, the reverse current protection mode and the normal operation mode are repeated.

5. Output voltage vs. Ambient temperature

5.1 $V_{OUT(S)} = 1.2\text{ V}$

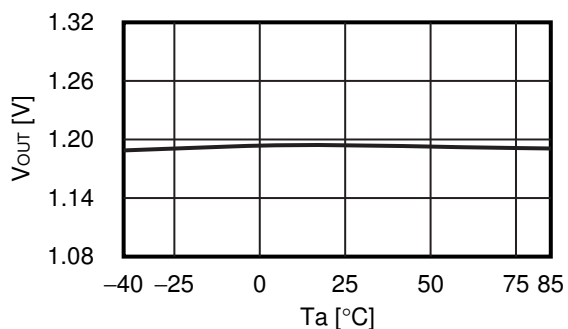

5.2 $V_{OUT(S)} = 3.0\text{ V}$

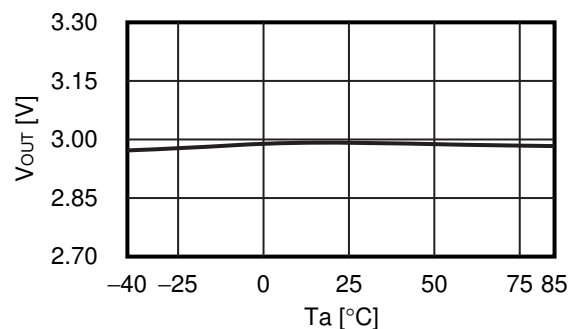

5.3 $V_{OUT(S)} = 4.0\text{ V}$

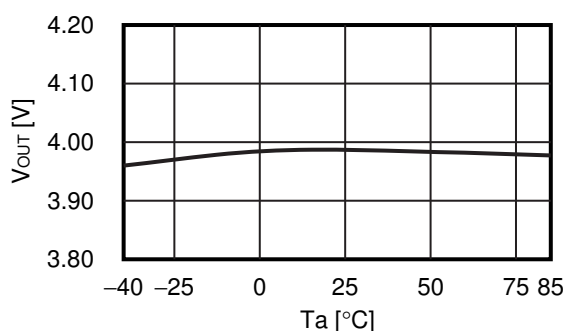

6. Current consumption vs. Input voltage

6.1 $V_{OUT(S)} = 1.2\text{ V}$

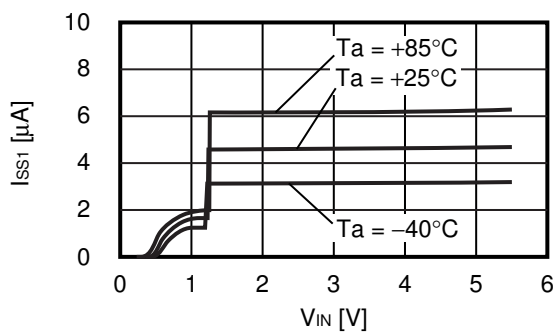

6.2 $V_{OUT(S)} = 3.0\text{ V}$

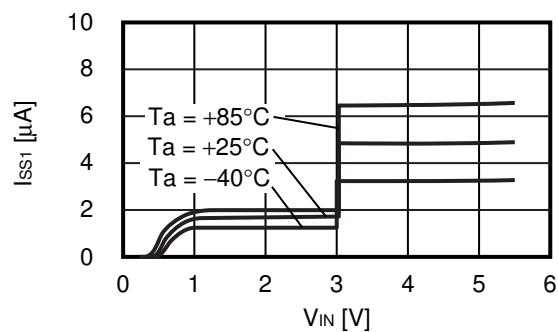

6.3 $V_{OUT(S)} = 4.0\text{ V}$

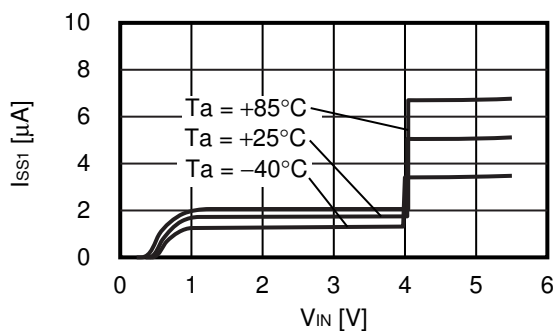

7. Reverse current vs. VOUT pin voltage

7.1 $V_{IN} = 0\text{ V}$

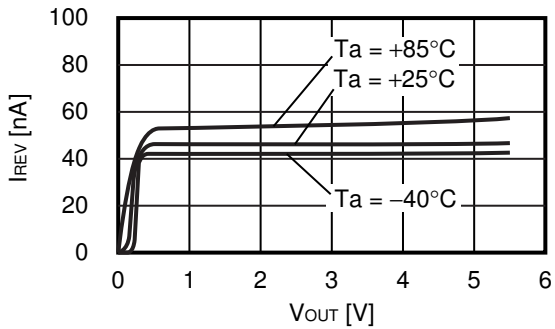

8. Ripple rejection ($T_a = +25^\circ\text{C}$)

8.1 $V_{OUT(S)} = 1.2\text{ V}$

$V_{IN} = 2.2\text{ V}, C_L = 1.0\ \mu\text{F}$

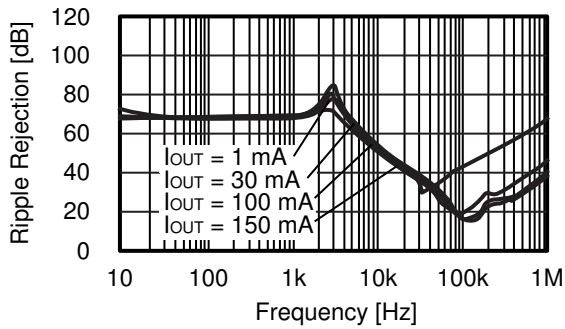

8.2 $V_{OUT(S)} = 3.0\text{ V}$

$V_{IN} = 4.0\text{ V}, C_L = 1.0\ \mu\text{F}$

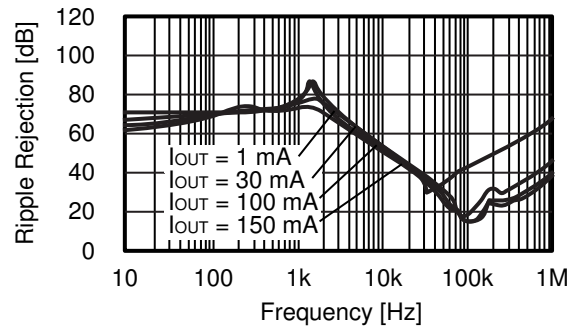

8.3 $V_{OUT(S)} = 4.0\text{ V}$

$V_{IN} = 5.0\text{ V}, C_L = 1.0\ \mu\text{F}$

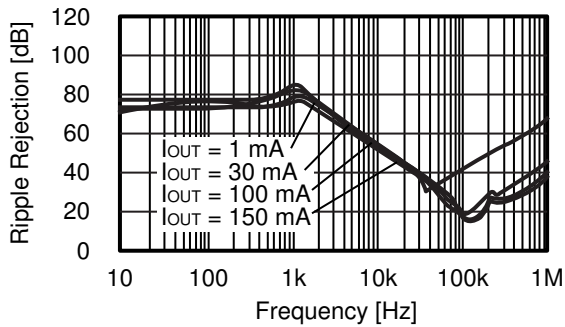

■ Reference Data

1. Transient response characteristics when input (Ta = +25°C)

1.1 V_{OUT(S)} = 1.2 V

$I_{OUT} = 30\text{ mA}$, $C_{IN} = C_L = 1.0\text{ }\mu\text{F}$, $V_{IN} = 2.2\text{ V} \leftrightarrow 3.2\text{ V}$, $t_r = t_f = 5.0\text{ }\mu\text{s}$

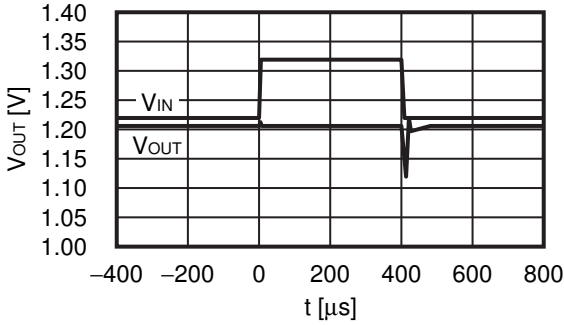

1.2 V_{OUT(S)} = 3.0 V

$I_{OUT} = 30\text{ mA}$, $C_{IN} = C_L = 1.0\text{ }\mu\text{F}$, $V_{IN} = 4.0\text{ V} \leftrightarrow 5.0\text{ V}$, $t_r = t_f = 5.0\text{ }\mu\text{s}$

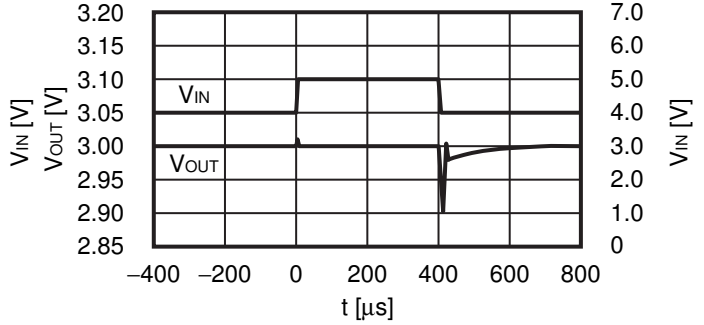

1.3 V_{OUT(S)} = 4.0 V

$I_{OUT} = 30\text{ mA}$, $C_{IN} = C_L = 1.0\text{ }\mu\text{F}$, $V_{IN} = 5.0\text{ V} \leftrightarrow 5.5\text{ V}$, $t_r = t_f = 5.0\text{ }\mu\text{s}$

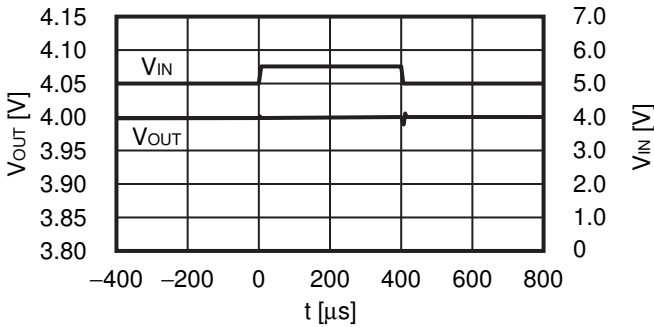

2. Transient response characteristics of load (Ta = +25°C)

2.1 V_{OUT(S)} = 1.2 V

$V_{IN} = 2.2\text{ V}$, $C_{IN} = C_L = 1.0\text{ }\mu\text{F}$, $I_{OUT} = 50\text{ mA} \leftrightarrow 100\text{ mA}$

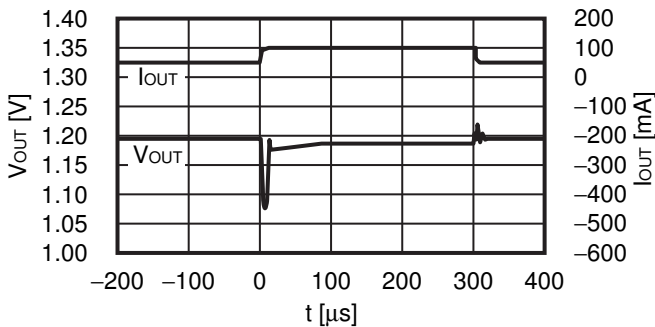

$V_{IN} = 2.2\text{ V}$, $C_{IN} = C_L = 1.0\text{ }\mu\text{F}$, $I_{OUT} = 1\text{ mA} \leftrightarrow 150\text{ mA}$

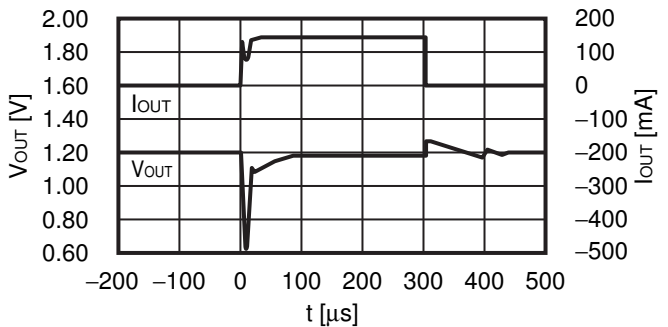

2.2 V_{OUT(S)} = 3.0 V

$V_{IN} = 4.0\text{ V}$, $C_{IN} = C_L = 1.0\text{ }\mu\text{F}$, $I_{OUT} = 50\text{ mA} \leftrightarrow 100\text{ mA}$

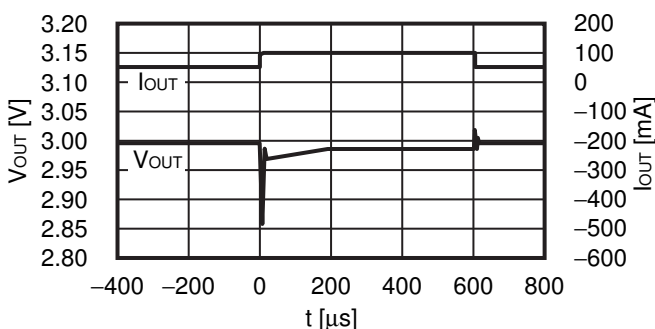

$V_{IN} = 4.0\text{ V}$, $C_{IN} = C_L = 1.0\text{ }\mu\text{F}$, $I_{OUT} = 1\text{ mA} \leftrightarrow 150\text{ mA}$

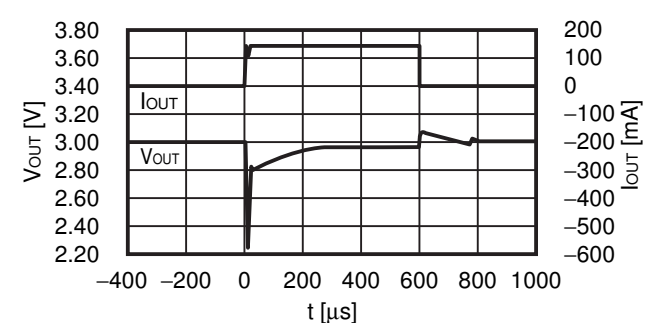

2.3 $V_{OUT(S)} = 4.0\text{ V}$

$V_{IN} = 5.0\text{ V}$, $C_{IN} = C_L = 1.0\ \mu\text{F}$, $I_{OUT} = 50\text{ mA} \leftrightarrow 100\text{ mA}$

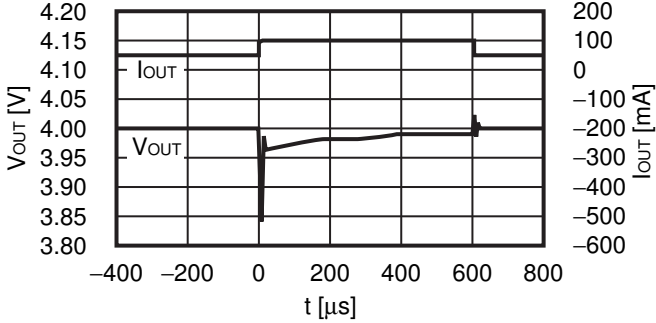

$V_{IN} = 5.0\text{ V}$, $C_{IN} = C_L = 1.0\ \mu\text{F}$, $I_{OUT} = 1\text{ mA} \leftrightarrow 150\text{ mA}$

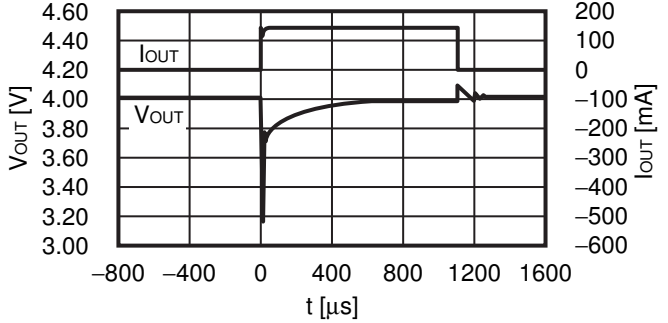

3. Transient response characteristics of ON / OFF pin when rising ($T_a = +25^\circ\text{C}$)

3.1 $V_{OUT(S)} = 1.2\text{ V}$

$V_{IN} = 2.2\text{ V}$, $C_{IN} = C_L = 1.0\ \mu\text{F}$, $I_{OUT} = 100\text{ mA}$,
 $V_{ON/OFF} = 0\text{ V} \rightarrow 2.2\text{ V}$, $t_r = 1.0\ \mu\text{s}$

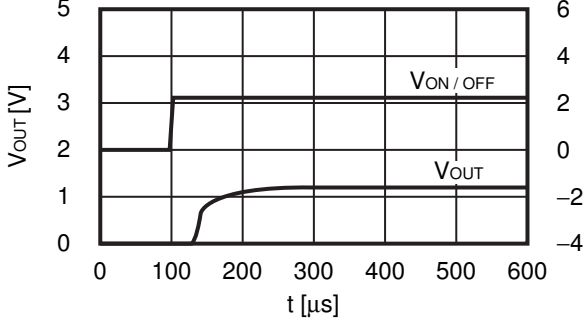

3.2 $V_{OUT(S)} = 3.0\text{ V}$

$V_{IN} = 4.0\text{ V}$, $C_{IN} = C_L = 1.0\ \mu\text{F}$, $I_{OUT} = 100\text{ mA}$,
 $V_{ON/OFF} = 0\text{ V} \rightarrow 4.0\text{ V}$, $t_r = 1.0\ \mu\text{s}$

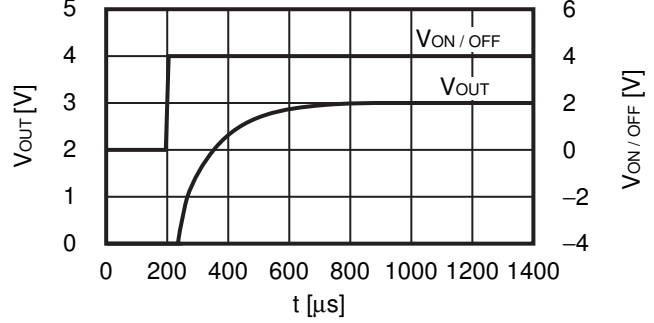

3.3 $V_{OUT(S)} = 4.0\text{ V}$

$V_{IN} = 5.0\text{ V}$, $C_{IN} = C_L = 1.0\ \mu\text{F}$, $I_{OUT} = 100\text{ mA}$,
 $V_{ON/OFF} = 0\text{ V} \rightarrow 5.0\text{ V}$, $t_r = 1.0\ \mu\text{s}$

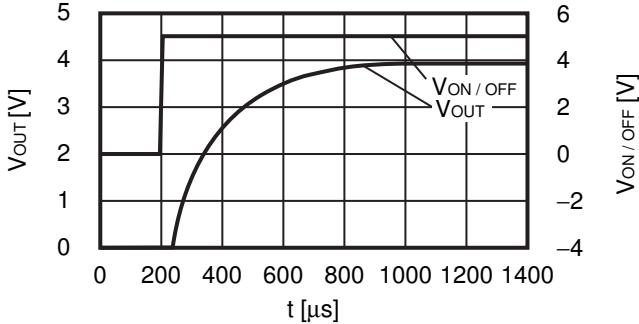

4. Output capacitance vs. Characteristics of discharge time (Ta = +25°C)

$V_{IN} = V_{OUT(S)} + 1.0 \text{ V}$, $C_{IN} = 1.0 \mu\text{F}$, $I_{OUT} = \text{no load}$,
 $V_{ON/OFF} = V_{OUT(S)} + 1.0 \text{ V} \rightarrow 0 \text{ V}$, $t_f = 1.0 \mu\text{s}$

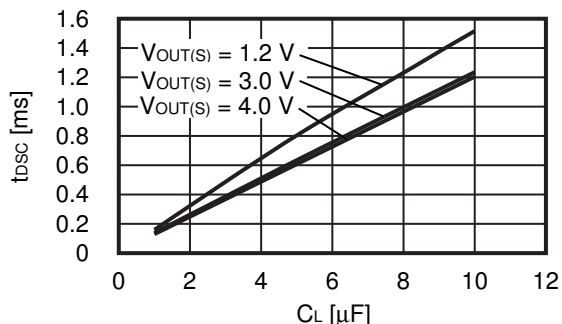

Figure 26 S-13R1 Series A / B type (with discharge shunt function)

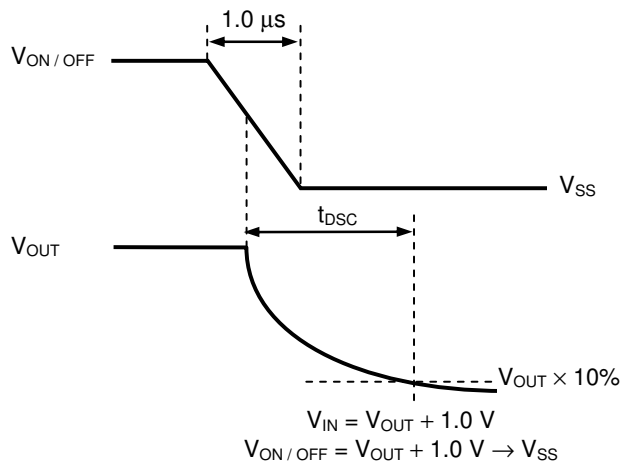

Figure 27 Test Condition of Discharge Time

5. Example of equivalent series resistance vs. Output current characteristics (Ta = +25°C)

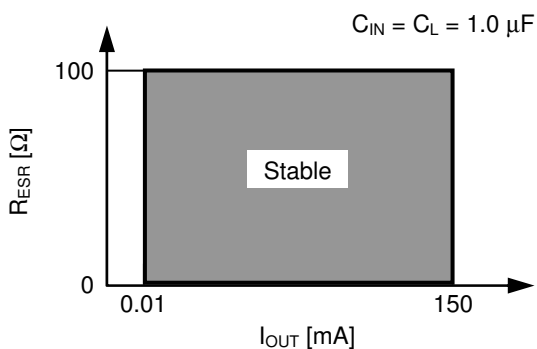
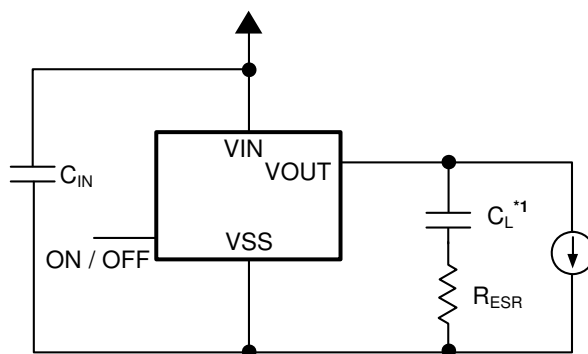

Figure 28



*1. C_L : ROHM Co.,Ltd. MCH184FN105Z (1.0 μF)

Figure 29

■ **Marking Specifications**

1. SOT-23-5

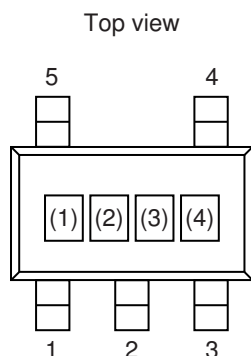

(1) to (3): Product code (Refer to **Product name vs. Product code**)
 (4): Lot number

Product name vs. Product code

1.1 S-13R1 Series A type

Product Name	Product Code		
	(1)	(2)	(3)
S-13R1A12-M5T1U3	2	A	A
S-13R1A13-M5T1U3	2	A	B
S-13R1A14-M5T1U3	2	A	C
S-13R1A15-M5T1U3	2	A	D
S-13R1A16-M5T1U3	2	A	E
S-13R1A17-M5T1U3	2	A	F
S-13R1A18-M5T1U3	2	A	G
S-13R1A1J-M5T1U3	2	A	5
S-13R1A19-M5T1U3	2	A	H
S-13R1A20-M5T1U3	2	A	I
S-13R1A21-M5T1U3	2	A	J
S-13R1A22-M5T1U3	2	A	K
S-13R1A23-M5T1U3	2	A	L
S-13R1A24-M5T1U3	2	A	M
S-13R1A25-M5T1U3	2	A	N
S-13R1A26-M5T1U3	2	A	O
S-13R1A27-M5T1U3	2	A	P
S-13R1A28-M5T1U3	2	A	Q
S-13R1A2J-M5T1U3	2	A	6
S-13R1A29-M5T1U3	2	A	R
S-13R1A30-M5T1U3	2	A	S
S-13R1A31-M5T1U3	2	A	T
S-13R1A32-M5T1U3	2	A	U
S-13R1A33-M5T1U3	2	A	V
S-13R1A34-M5T1U3	2	A	W
S-13R1A35-M5T1U3	2	A	X
S-13R1A36-M5T1U3	2	A	Y
S-13R1A37-M5T1U3	2	A	Z
S-13R1A38-M5T1U3	2	A	2
S-13R1A39-M5T1U3	2	A	3
S-13R1A40-M5T1U3	2	A	4

1.2 S-13R1 Series B type

Product Name	Product Code		
	(1)	(2)	(3)
S-13R1B12-M5T1U3	2	B	A
S-13R1B13-M5T1U3	2	B	B
S-13R1B14-M5T1U3	2	B	C
S-13R1B15-M5T1U3	2	B	D
S-13R1B16-M5T1U3	2	B	E
S-13R1B17-M5T1U3	2	B	F
S-13R1B18-M5T1U3	2	B	G
S-13R1B1J-M5T1U3	2	B	5
S-13R1B19-M5T1U3	2	B	H
S-13R1B20-M5T1U3	2	B	I
S-13R1B21-M5T1U3	2	B	J
S-13R1B22-M5T1U3	2	B	K
S-13R1B23-M5T1U3	2	B	L
S-13R1B24-M5T1U3	2	B	M
S-13R1B25-M5T1U3	2	B	N
S-13R1B26-M5T1U3	2	B	O
S-13R1B27-M5T1U3	2	B	P
S-13R1B28-M5T1U3	2	B	Q
S-13R1B2J-M5T1U3	2	B	6
S-13R1B29-M5T1U3	2	B	R
S-13R1B30-M5T1U3	2	B	S
S-13R1B31-M5T1U3	2	B	T
S-13R1B32-M5T1U3	2	B	U
S-13R1B33-M5T1U3	2	B	V
S-13R1B34-M5T1U3	2	B	W
S-13R1B35-M5T1U3	2	B	X
S-13R1B36-M5T1U3	2	B	Y
S-13R1B37-M5T1U3	2	B	Z
S-13R1B38-M5T1U3	2	B	2
S-13R1B39-M5T1U3	2	B	3
S-13R1B40-M5T1U3	2	B	4

REVERSE CURRENT PROTECTION CMOS VOLTAGE REGULATOR

S-13R1 Series

Rev.1.1_00

1.3 S-13R1 Series C type

Product Name	Product Code		
	(1)	(2)	(3)
S-13R1C12-M5T1U3	2	C	A
S-13R1C13-M5T1U3	2	C	B
S-13R1C14-M5T1U3	2	C	C
S-13R1C15-M5T1U3	2	C	D
S-13R1C16-M5T1U3	2	C	E
S-13R1C17-M5T1U3	2	C	F
S-13R1C18-M5T1U3	2	C	G
S-13R1C1J-M5T1U3	2	C	5
S-13R1C19-M5T1U3	2	C	H
S-13R1C20-M5T1U3	2	C	I
S-13R1C21-M5T1U3	2	C	J
S-13R1C22-M5T1U3	2	C	K
S-13R1C23-M5T1U3	2	C	L
S-13R1C24-M5T1U3	2	C	M
S-13R1C25-M5T1U3	2	C	N
S-13R1C26-M5T1U3	2	C	O
S-13R1C27-M5T1U3	2	C	P
S-13R1C28-M5T1U3	2	C	Q
S-13R1C2J-M5T1U3	2	C	6
S-13R1C29-M5T1U3	2	C	R
S-13R1C30-M5T1U3	2	C	S
S-13R1C31-M5T1U3	2	C	T
S-13R1C32-M5T1U3	2	C	U
S-13R1C33-M5T1U3	2	C	V
S-13R1C34-M5T1U3	2	C	W
S-13R1C35-M5T1U3	2	C	X
S-13R1C36-M5T1U3	2	C	Y
S-13R1C37-M5T1U3	2	C	Z
S-13R1C38-M5T1U3	2	C	2
S-13R1C39-M5T1U3	2	C	3
S-13R1C40-M5T1U3	2	C	4

1.4 S-13R1 Series D type

Product Name	Product Code		
	(1)	(2)	(3)
S-13R1D12-M5T1U3	2	D	A
S-13R1D13-M5T1U3	2	D	B
S-13R1D14-M5T1U3	2	D	C
S-13R1D15-M5T1U3	2	D	D
S-13R1D16-M5T1U3	2	D	E
S-13R1D17-M5T1U3	2	D	F
S-13R1D18-M5T1U3	2	D	G
S-13R1D1J-M5T1U3	2	D	5
S-13R1D19-M5T1U3	2	D	H
S-13R1D20-M5T1U3	2	D	I
S-13R1D21-M5T1U3	2	D	J
S-13R1D22-M5T1U3	2	D	K
S-13R1D23-M5T1U3	2	D	L
S-13R1D24-M5T1U3	2	D	M
S-13R1D25-M5T1U3	2	D	N
S-13R1D26-M5T1U3	2	D	O
S-13R1D27-M5T1U3	2	D	P
S-13R1D28-M5T1U3	2	D	Q
S-13R1D2J-M5T1U3	2	D	6
S-13R1D29-M5T1U3	2	D	R
S-13R1D30-M5T1U3	2	D	S
S-13R1D31-M5T1U3	2	D	T
S-13R1D32-M5T1U3	2	D	U
S-13R1D33-M5T1U3	2	D	V
S-13R1D34-M5T1U3	2	D	W
S-13R1D35-M5T1U3	2	D	X
S-13R1D36-M5T1U3	2	D	Y
S-13R1D37-M5T1U3	2	D	Z
S-13R1D38-M5T1U3	2	D	2
S-13R1D39-M5T1U3	2	D	3
S-13R1D40-M5T1U3	2	D	4

2. SC-82AB

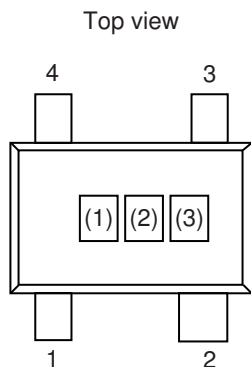

(1) to (3): Product code (Refer to **Product name vs. Product code**)

Product name vs. Product code

2.1 S-13R1 Series A type

Product Name	Product Code		
	(1)	(2)	(3)
S-13R1A12-N4T1U3	2	A	A
S-13R1A13-N4T1U3	2	A	B
S-13R1A14-N4T1U3	2	A	C
S-13R1A15-N4T1U3	2	A	D
S-13R1A16-N4T1U3	2	A	E
S-13R1A17-N4T1U3	2	A	F
S-13R1A18-N4T1U3	2	A	G
S-13R1A1J-N4T1U3	2	A	5
S-13R1A19-N4T1U3	2	A	H
S-13R1A20-N4T1U3	2	A	I
S-13R1A21-N4T1U3	2	A	J
S-13R1A22-N4T1U3	2	A	K
S-13R1A23-N4T1U3	2	A	L
S-13R1A24-N4T1U3	2	A	M
S-13R1A25-N4T1U3	2	A	N
S-13R1A26-N4T1U3	2	A	O
S-13R1A27-N4T1U3	2	A	P
S-13R1A28-N4T1U3	2	A	Q
S-13R1A2J-N4T1U3	2	A	6
S-13R1A29-N4T1U3	2	A	R
S-13R1A30-N4T1U3	2	A	S
S-13R1A31-N4T1U3	2	A	T
S-13R1A32-N4T1U3	2	A	U
S-13R1A33-N4T1U3	2	A	V
S-13R1A34-N4T1U3	2	A	W
S-13R1A35-N4T1U3	2	A	X
S-13R1A36-N4T1U3	2	A	Y
S-13R1A37-N4T1U3	2	A	Z
S-13R1A38-N4T1U3	2	A	2
S-13R1A39-N4T1U3	2	A	3
S-13R1A40-N4T1U3	2	A	4

2.2 S-13R1 Series B type

Product Name	Product Code		
	(1)	(2)	(3)
S-13R1B12-N4T1U3	2	B	A
S-13R1B13-N4T1U3	2	B	B
S-13R1B14-N4T1U3	2	B	C
S-13R1B15-N4T1U3	2	B	D
S-13R1B16-N4T1U3	2	B	E
S-13R1B17-N4T1U3	2	B	F
S-13R1B18-N4T1U3	2	B	G
S-13R1B1J-N4T1U3	2	B	5
S-13R1B19-N4T1U3	2	B	H
S-13R1B20-N4T1U3	2	B	I
S-13R1B21-N4T1U3	2	B	J
S-13R1B22-N4T1U3	2	B	K
S-13R1B23-N4T1U3	2	B	L
S-13R1B24-N4T1U3	2	B	M
S-13R1B25-N4T1U3	2	B	N
S-13R1B26-N4T1U3	2	B	O
S-13R1B27-N4T1U3	2	B	P
S-13R1B28-N4T1U3	2	B	Q
S-13R1B2J-N4T1U3	2	B	6
S-13R1B29-N4T1U3	2	B	R
S-13R1B30-N4T1U3	2	B	S
S-13R1B31-N4T1U3	2	B	T
S-13R1B32-N4T1U3	2	B	U
S-13R1B33-N4T1U3	2	B	V
S-13R1B34-N4T1U3	2	B	W
S-13R1B35-N4T1U3	2	B	X
S-13R1B36-N4T1U3	2	B	Y
S-13R1B37-N4T1U3	2	B	Z
S-13R1B38-N4T1U3	2	B	2
S-13R1B39-N4T1U3	2	B	3
S-13R1B40-N4T1U3	2	B	4

REVERSE CURRENT PROTECTION CMOS VOLTAGE REGULATOR

S-13R1 Series

Rev.1.1_00

2.3 S-13R1 Series C type

Product Name	Product Code		
	(1)	(2)	(3)
S-13R1C12-N4T1U3	2	C	A
S-13R1C13-N4T1U3	2	C	B
S-13R1C14-N4T1U3	2	C	C
S-13R1C15-N4T1U3	2	C	D
S-13R1C16-N4T1U3	2	C	E
S-13R1C17-N4T1U3	2	C	F
S-13R1C18-N4T1U3	2	C	G
S-13R1C1J-N4T1U3	2	C	5
S-13R1C19-N4T1U3	2	C	H
S-13R1C20-N4T1U3	2	C	I
S-13R1C21-N4T1U3	2	C	J
S-13R1C22-N4T1U3	2	C	K
S-13R1C23-N4T1U3	2	C	L
S-13R1C24-N4T1U3	2	C	M
S-13R1C25-N4T1U3	2	C	N
S-13R1C26-N4T1U3	2	C	O
S-13R1C27-N4T1U3	2	C	P
S-13R1C28-N4T1U3	2	C	Q
S-13R1C2J-N4T1U3	2	C	6
S-13R1C29-N4T1U3	2	C	R
S-13R1C30-N4T1U3	2	C	S
S-13R1C31-N4T1U3	2	C	T
S-13R1C32-N4T1U3	2	C	U
S-13R1C33-N4T1U3	2	C	V
S-13R1C34-N4T1U3	2	C	W
S-13R1C35-N4T1U3	2	C	X
S-13R1C36-N4T1U3	2	C	Y
S-13R1C37-N4T1U3	2	C	Z
S-13R1C38-N4T1U3	2	C	2
S-13R1C39-N4T1U3	2	C	3
S-13R1C40-N4T1U3	2	C	4

2.4 S-13R1 Series D type

Product Name	Product Code		
	(1)	(2)	(3)
S-13R1D12-N4T1U3	2	D	A
S-13R1D13-N4T1U3	2	D	B
S-13R1D14-N4T1U3	2	D	C
S-13R1D15-N4T1U3	2	D	D
S-13R1D16-N4T1U3	2	D	E
S-13R1D17-N4T1U3	2	D	F
S-13R1D18-N4T1U3	2	D	G
S-13R1D1J-N4T1U3	2	D	5
S-13R1D19-N4T1U3	2	D	H
S-13R1D20-N4T1U3	2	D	I
S-13R1D21-N4T1U3	2	D	J
S-13R1D22-N4T1U3	2	D	K
S-13R1D23-N4T1U3	2	D	L
S-13R1D24-N4T1U3	2	D	M
S-13R1D25-N4T1U3	2	D	N
S-13R1D26-N4T1U3	2	D	O
S-13R1D27-N4T1U3	2	D	P
S-13R1D28-N4T1U3	2	D	Q
S-13R1D2J-N4T1U3	2	D	6
S-13R1D29-N4T1U3	2	D	R
S-13R1D30-N4T1U3	2	D	S
S-13R1D31-N4T1U3	2	D	T
S-13R1D32-N4T1U3	2	D	U
S-13R1D33-N4T1U3	2	D	V
S-13R1D34-N4T1U3	2	D	W
S-13R1D35-N4T1U3	2	D	X
S-13R1D36-N4T1U3	2	D	Y
S-13R1D37-N4T1U3	2	D	Z
S-13R1D38-N4T1U3	2	D	2
S-13R1D39-N4T1U3	2	D	3
S-13R1D40-N4T1U3	2	D	4

3. HSNT-4 (1010)

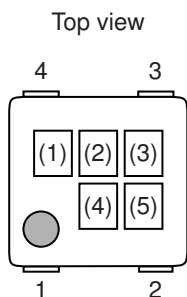

(1) to (3): Product code (Refer to **Product name vs. Product code**)
 (4), (5): Lot number

Product name vs. Product code

3.1 S-13R1 Series A type

Product Name	Product Code		
	(1)	(2)	(3)
S-13R1A12-A4T2U3	2	A	A
S-13R1A13-A4T2U3	2	A	B
S-13R1A14-A4T2U3	2	A	C
S-13R1A15-A4T2U3	2	A	D
S-13R1A16-A4T2U3	2	A	E
S-13R1A17-A4T2U3	2	A	F
S-13R1A18-A4T2U3	2	A	G
S-13R1A1J-A4T2U3	2	A	5
S-13R1A19-A4T2U3	2	A	H
S-13R1A20-A4T2U3	2	A	I
S-13R1A21-A4T2U3	2	A	J
S-13R1A22-A4T2U3	2	A	K
S-13R1A23-A4T2U3	2	A	L
S-13R1A24-A4T2U3	2	A	M
S-13R1A25-A4T2U3	2	A	N
S-13R1A26-A4T2U3	2	A	O
S-13R1A27-A4T2U3	2	A	P
S-13R1A28-A4T2U3	2	A	Q
S-13R1A2J-A4T2U3	2	A	6
S-13R1A29-A4T2U3	2	A	R
S-13R1A30-A4T2U3	2	A	S
S-13R1A31-A4T2U3	2	A	T
S-13R1A32-A4T2U3	2	A	U
S-13R1A33-A4T2U3	2	A	V
S-13R1A34-A4T2U3	2	A	W
S-13R1A35-A4T2U3	2	A	X
S-13R1A36-A4T2U3	2	A	Y
S-13R1A37-A4T2U3	2	A	Z
S-13R1A38-A4T2U3	2	A	2
S-13R1A39-A4T2U3	2	A	3
S-13R1A40-A4T2U3	2	A	4

3.2 S-13R1 Series B type

Product Name	Product Code		
	(1)	(2)	(3)
S-13R1B12-A4T2U3	2	B	A
S-13R1B13-A4T2U3	2	B	B
S-13R1B14-A4T2U3	2	B	C
S-13R1B15-A4T2U3	2	B	D
S-13R1B16-A4T2U3	2	B	E
S-13R1B17-A4T2U3	2	B	F
S-13R1B18-A4T2U3	2	B	G
S-13R1B1J-A4T2U3	2	B	5
S-13R1B19-A4T2U3	2	B	H
S-13R1B20-A4T2U3	2	B	I
S-13R1B21-A4T2U3	2	B	J
S-13R1B22-A4T2U3	2	B	K
S-13R1B23-A4T2U3	2	B	L
S-13R1B24-A4T2U3	2	B	M
S-13R1B25-A4T2U3	2	B	N
S-13R1B26-A4T2U3	2	B	O
S-13R1B27-A4T2U3	2	B	P
S-13R1B28-A4T2U3	2	B	Q
S-13R1B2J-A4T2U3	2	B	6
S-13R1B29-A4T2U3	2	B	R
S-13R1B30-A4T2U3	2	B	S
S-13R1B31-A4T2U3	2	B	T
S-13R1B32-A4T2U3	2	B	U
S-13R1B33-A4T2U3	2	B	V
S-13R1B34-A4T2U3	2	B	W
S-13R1B35-A4T2U3	2	B	X
S-13R1B36-A4T2U3	2	B	Y
S-13R1B37-A4T2U3	2	B	Z
S-13R1B38-A4T2U3	2	B	2
S-13R1B39-A4T2U3	2	B	3
S-13R1B40-A4T2U3	2	B	4

REVERSE CURRENT PROTECTION CMOS VOLTAGE REGULATOR

S-13R1 Series

Rev.1.1_00

3.3 S-13R1 Series C type

Product Name	Product Code		
	(1)	(2)	(3)
S-13R1C12-A4T2U3	2	C	A
S-13R1C13-A4T2U3	2	C	B
S-13R1C14-A4T2U3	2	C	C
S-13R1C15-A4T2U3	2	C	D
S-13R1C16-A4T2U3	2	C	E
S-13R1C17-A4T2U3	2	C	F
S-13R1C18-A4T2U3	2	C	G
S-13R1C1J-A4T2U3	2	C	5
S-13R1C19-A4T2U3	2	C	H
S-13R1C20-A4T2U3	2	C	I
S-13R1C21-A4T2U3	2	C	J
S-13R1C22-A4T2U3	2	C	K
S-13R1C23-A4T2U3	2	C	L
S-13R1C24-A4T2U3	2	C	M
S-13R1C25-A4T2U3	2	C	N
S-13R1C26-A4T2U3	2	C	O
S-13R1C27-A4T2U3	2	C	P
S-13R1C28-A4T2U3	2	C	Q
S-13R1C2J-A4T2U3	2	C	6
S-13R1C29-A4T2U3	2	C	R
S-13R1C30-A4T2U3	2	C	S
S-13R1C31-A4T2U3	2	C	T
S-13R1C32-A4T2U3	2	C	U
S-13R1C33-A4T2U3	2	C	V
S-13R1C34-A4T2U3	2	C	W
S-13R1C35-A4T2U3	2	C	X
S-13R1C36-A4T2U3	2	C	Y
S-13R1C37-A4T2U3	2	C	Z
S-13R1C38-A4T2U3	2	C	2
S-13R1C39-A4T2U3	2	C	3
S-13R1C40-A4T2U3	2	C	4

3.4 S-13R1 Series D type

Product Name	Product Code		
	(1)	(2)	(3)
S-13R1D12-A4T2U3	2	D	A
S-13R1D13-A4T2U3	2	D	B
S-13R1D14-A4T2U3	2	D	C
S-13R1D15-A4T2U3	2	D	D
S-13R1D16-A4T2U3	2	D	E
S-13R1D17-A4T2U3	2	D	F
S-13R1D18-A4T2U3	2	D	G
S-13R1D1J-A4T2U3	2	D	5
S-13R1D19-A4T2U3	2	D	H
S-13R1D20-A4T2U3	2	D	I
S-13R1D21-A4T2U3	2	D	J
S-13R1D22-A4T2U3	2	D	K
S-13R1D23-A4T2U3	2	D	L
S-13R1D24-A4T2U3	2	D	M
S-13R1D25-A4T2U3	2	D	N
S-13R1D26-A4T2U3	2	D	O
S-13R1D27-A4T2U3	2	D	P
S-13R1D28-A4T2U3	2	D	Q
S-13R1D2J-A4T2U3	2	D	6
S-13R1D29-A4T2U3	2	D	R
S-13R1D30-A4T2U3	2	D	S
S-13R1D31-A4T2U3	2	D	T
S-13R1D32-A4T2U3	2	D	U
S-13R1D33-A4T2U3	2	D	V
S-13R1D34-A4T2U3	2	D	W
S-13R1D35-A4T2U3	2	D	X
S-13R1D36-A4T2U3	2	D	Y
S-13R1D37-A4T2U3	2	D	Z
S-13R1D38-A4T2U3	2	D	2
S-13R1D39-A4T2U3	2	D	3
S-13R1D40-A4T2U3	2	D	4

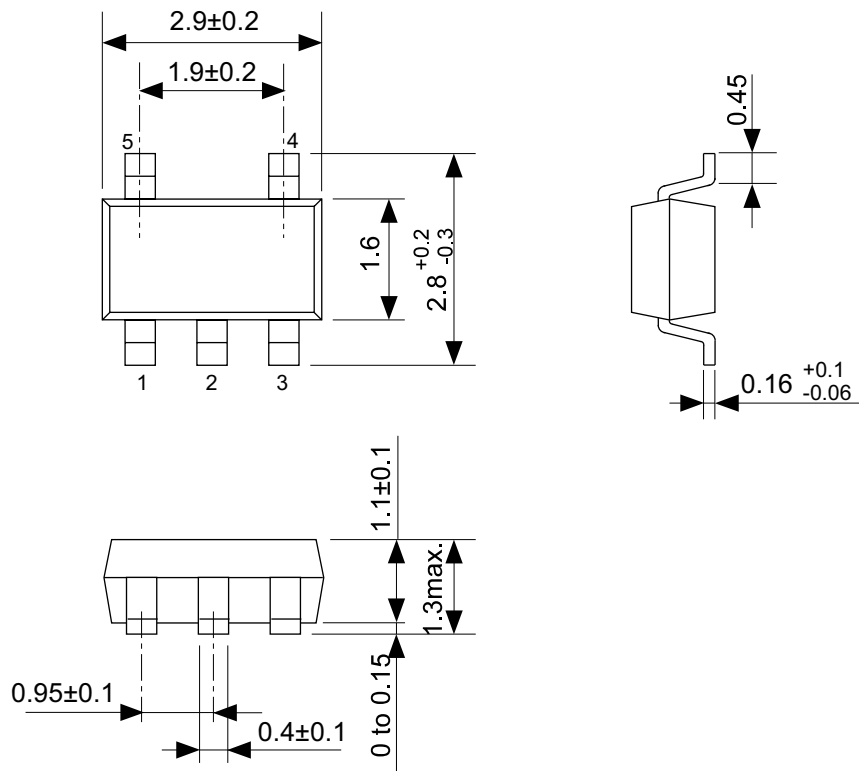

No. MP005-A-P-SD-1.2

TITLE	SOT235-A-PKG Dimensions
No.	MP005-A-P-SD-1.2
SCALE	
UNIT	mm
Seiko Instruments Inc.	

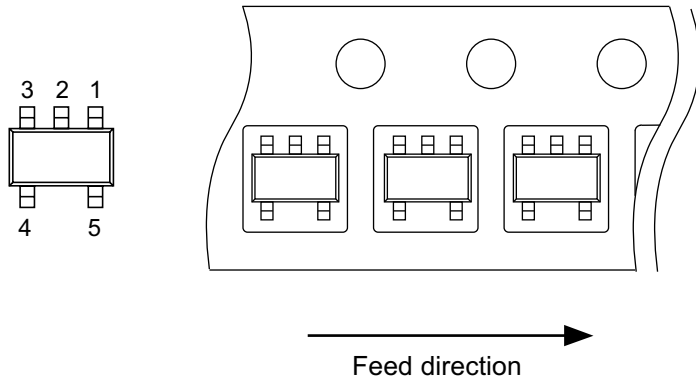
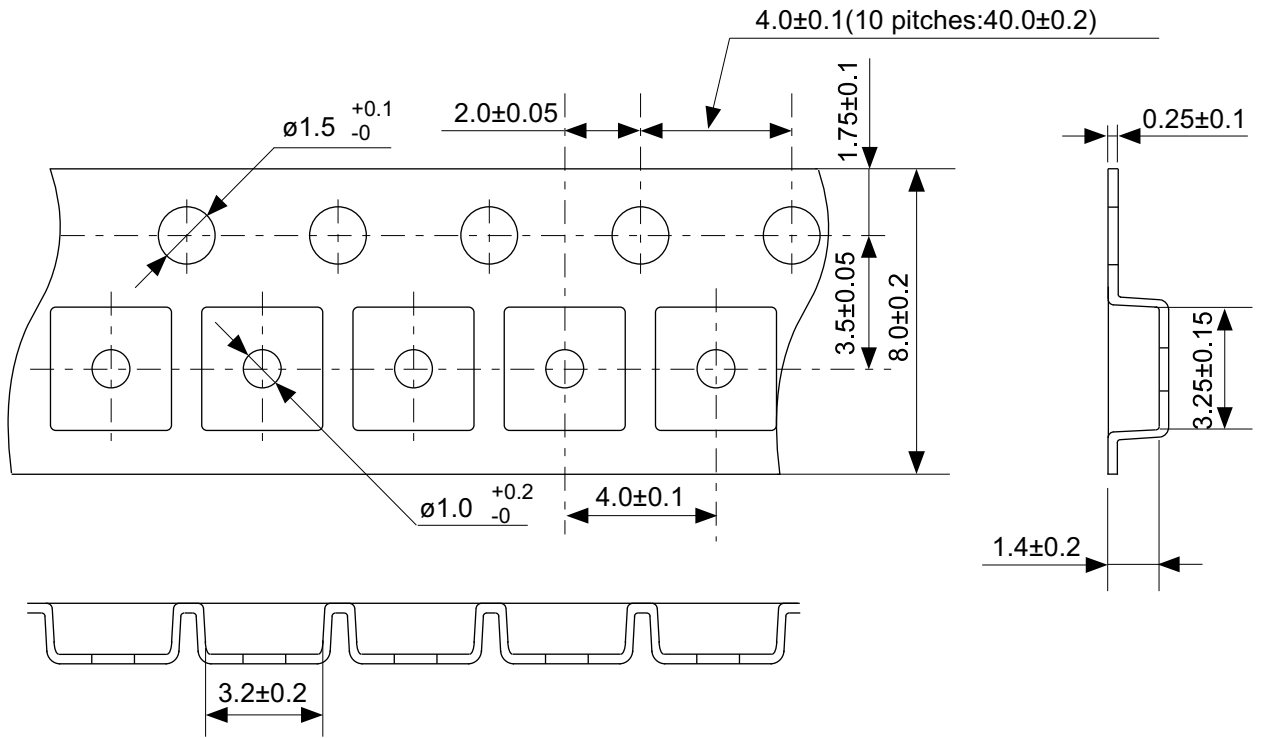

No. MP005-A-C-SD-2.1

TITLE	SOT235-A-Carrier Tape
No.	MP005-A-C-SD-2.1
SCALE	
UNIT	mm
Seiko Instruments Inc.	

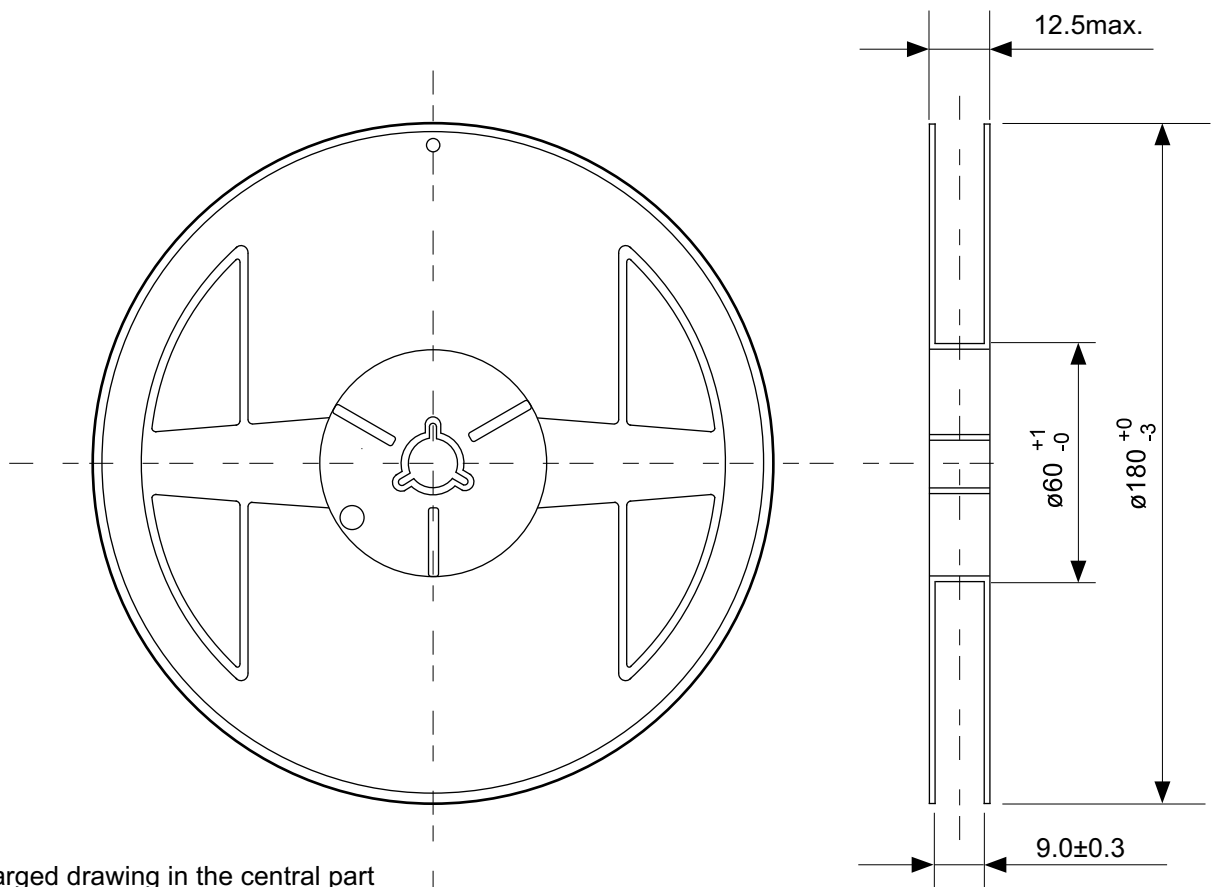

Enlarged drawing in the central part

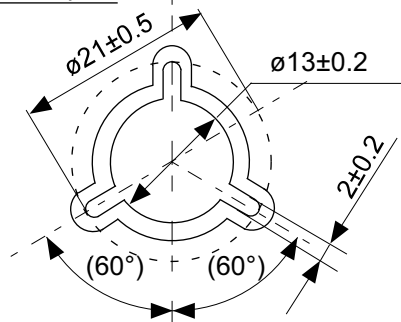

No. MP005-A-R-SD-1.1

TITLE	SOT235-A-Reel		
No.	MP005-A-R-SD-1.1		
SCALE		QTY.	3,000
UNIT	mm		
Seiko Instruments Inc.			

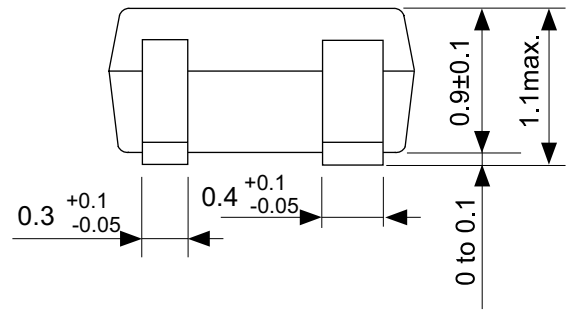
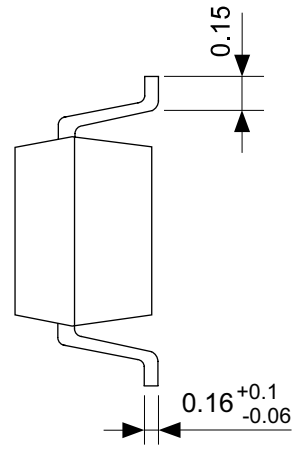
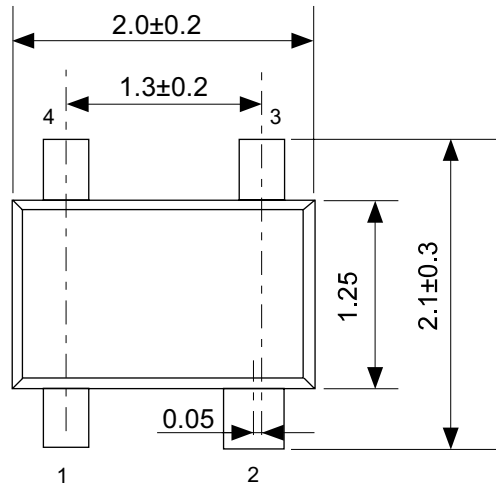

No. NP004-A-P-SD-1.1

TITLE	SC82AB-A-PKG Dimensions
No.	NP004-A-P-SD-1.1
SCALE	
UNIT	mm
Seiko Instruments Inc.	

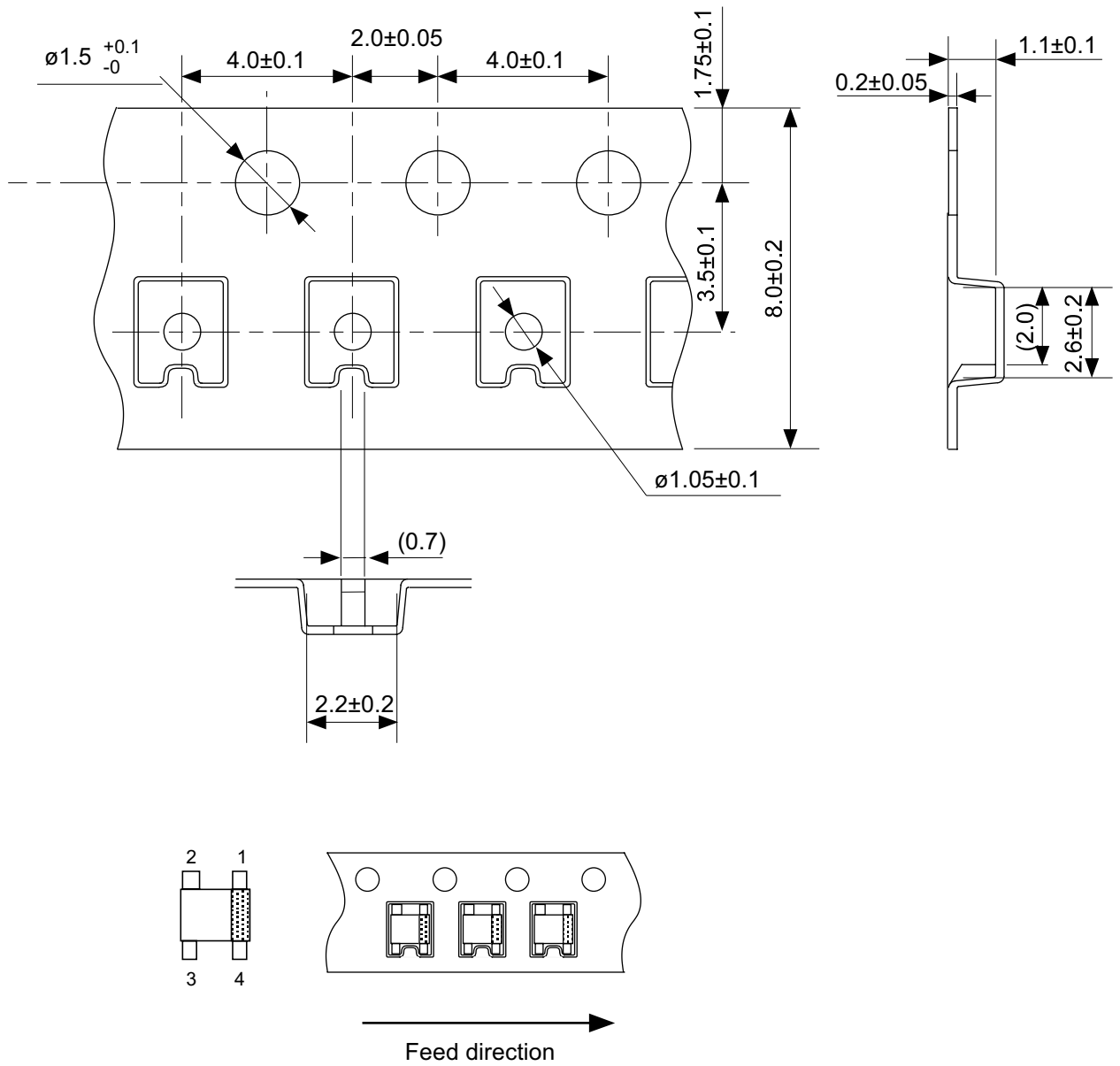

No. NP004-A-C-SD-3.0

TITLE	SC82AB-A-Carrier Tape
No.	NP004-A-C-SD-3.0
SCALE	
UNIT	mm
Seiko Instruments Inc.	

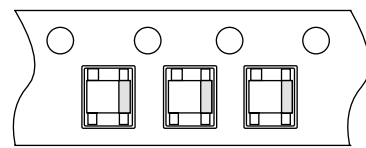
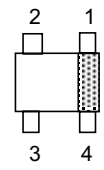
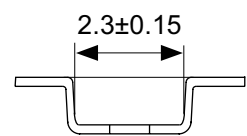
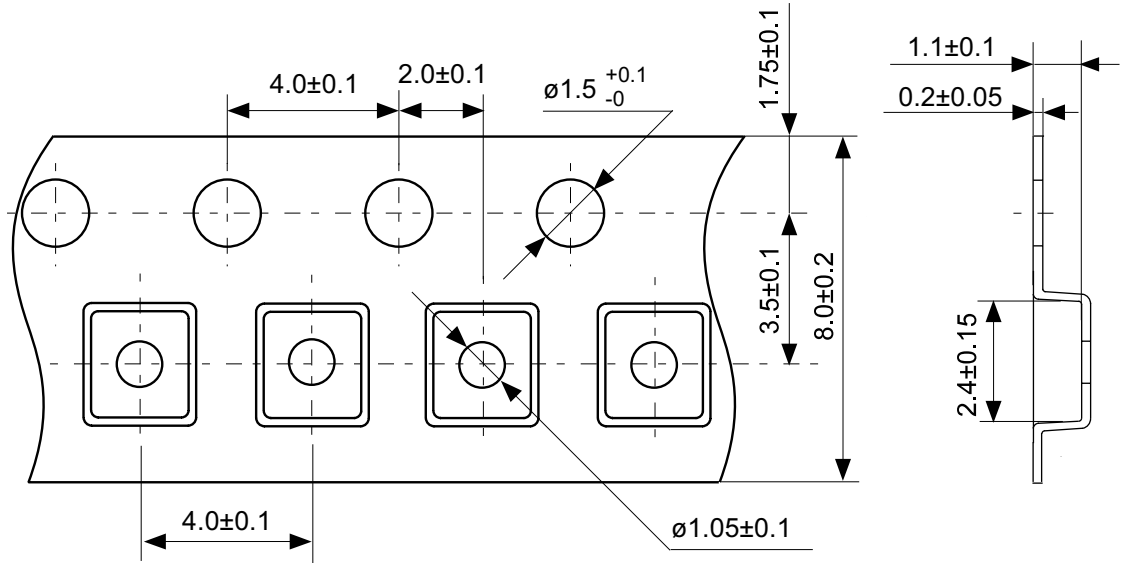

→
Feed direction

No. NP004-A-C-S1-2.0

TITLE	SC82AB-A-Carrier Tape
No.	NP004-A-C-S1-2.0
SCALE	
UNIT	mm

Seiko Instruments Inc.

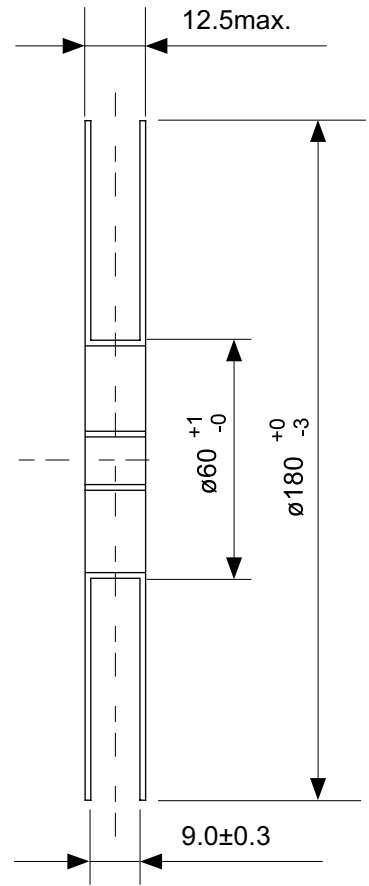
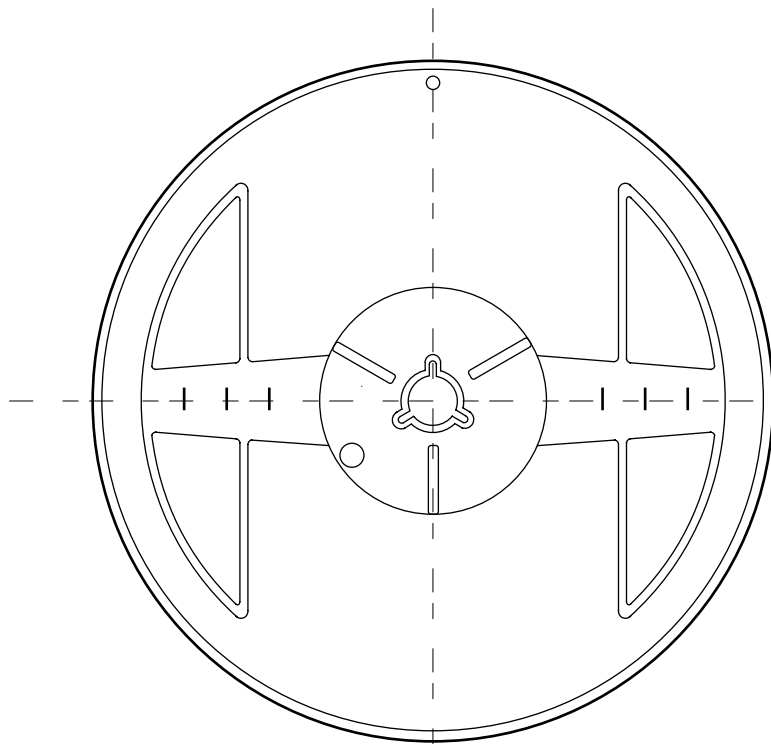

Enlarged drawing in the central part

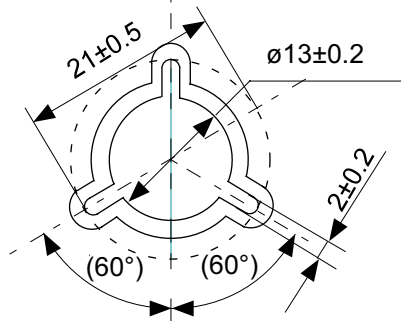

No. NP004-A-R-SD-1.1

TITLE	SC82AB-A-Reel		
No.	NP004-A-R-SD-1.1		
SCALE		QTY.	3,000
UNIT	mm		
Seiko Instruments Inc.			

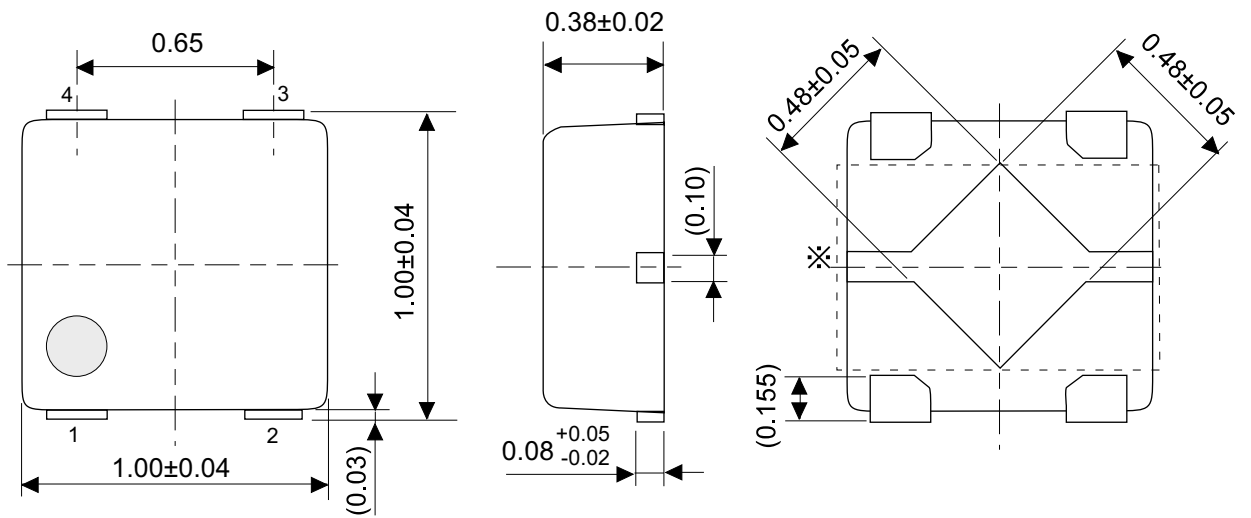

※ The heatsink of back side has different electric potential depending on the product. Confirm specifications of each product. Do not use it as the function of electrode.

No. PL004-A-P-SD-1.0

TITLE	HSNT-4-B-PKG Dimensions
No.	PL004-A-P-SD-1.0
SCALE	
UNIT	mm
Seiko Instruments Inc.	

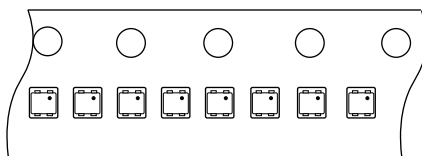
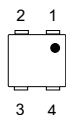
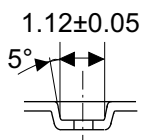
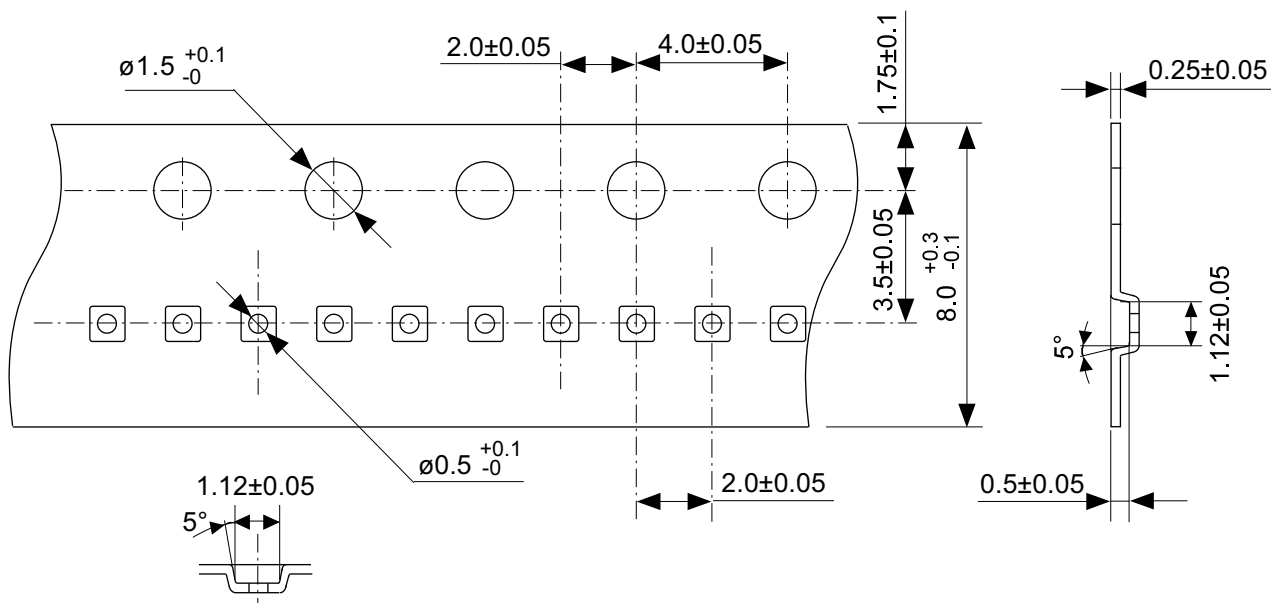

→
Feed direction

No. PL004-A-C-SD-1.0

TITLE	HSNT-4-B-Carrier Tape
No.	PL004-A-C-SD-1.0
SCALE	
UNIT	mm
Seiko Instruments Inc.	

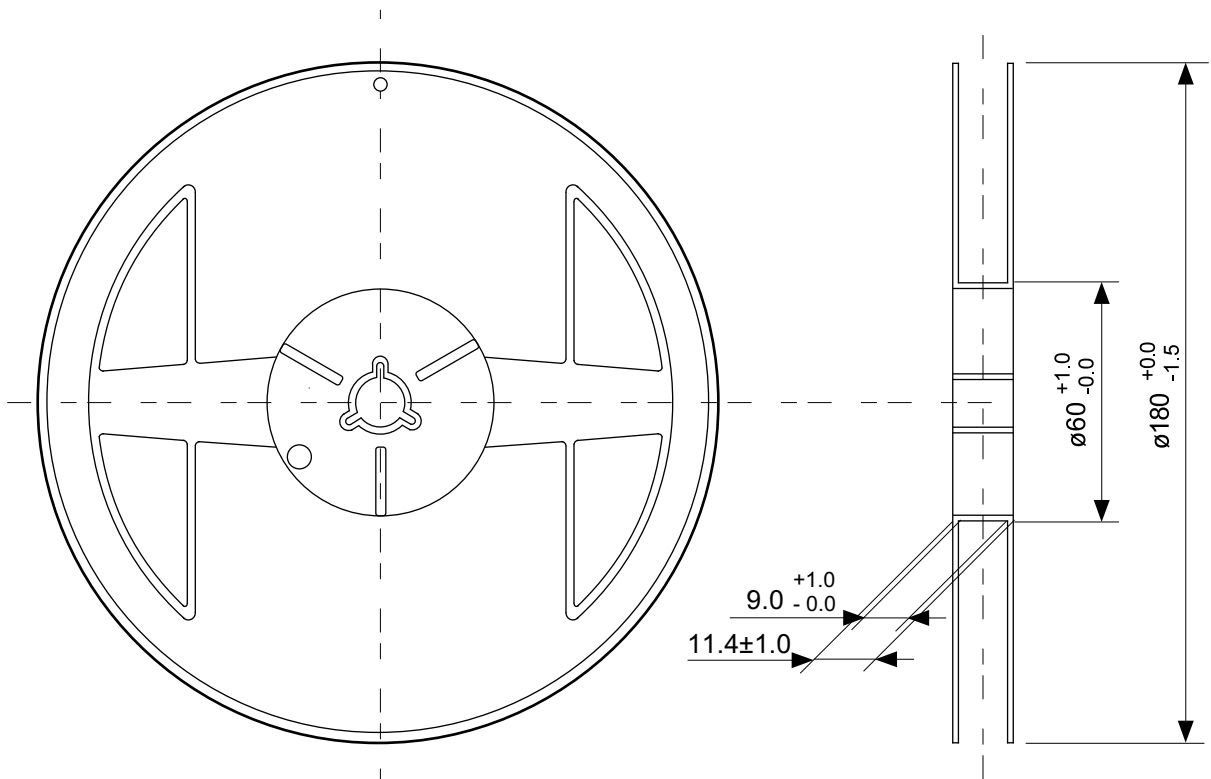

Enlarged drawing in the central part

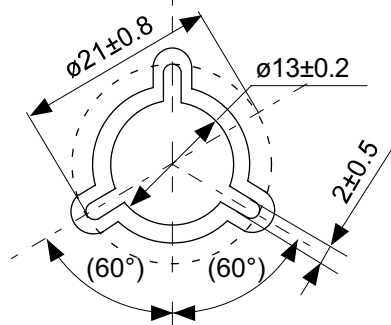

No. PL004-A-R-SD-1.0

TITLE	HSNT-4-B-Reel		
No.	PL004-A-R-SD-1.0		
SCALE		QTY.	10,000
UNIT	mm		
Seiko Instruments Inc.			

Land Pattern

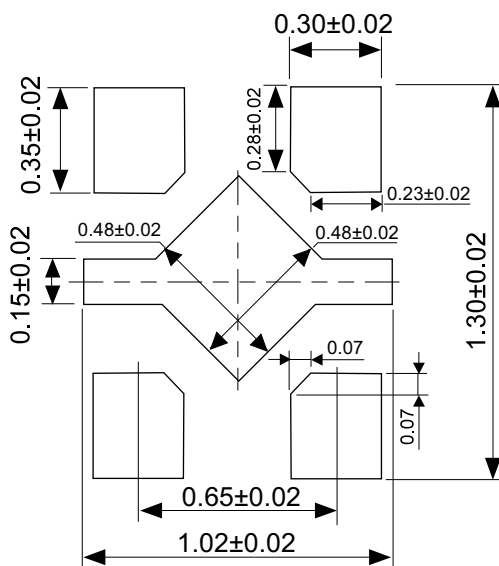

Caution It is recommended to solder the heatsink to a board in order to ensure the heat radiation.

注意 放熱性を確保する為に、PKGの裏面放熱板(ヒートシンク)を基板に半田付けする事を推奨いたします。

Metal Mask Pattern

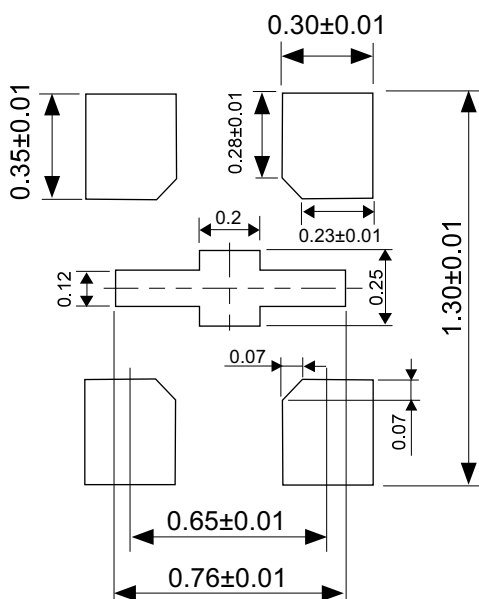

No. PL004-A-L-SD-1.0

TITLE	HSNT-4-B-Land Recommendation
No.	PL004-A-L-SD-1.0
SCALE	
UNIT	mm
Seiko Instruments Inc.	



Seiko Instruments Inc.
www.sii-ic.com

- The information described herein is subject to change without notice.
- Seiko Instruments Inc. is not responsible for any problems caused by circuits or diagrams described herein whose related industrial properties, patents, or other rights belong to third parties. The application circuit examples explain typical applications of the products, and do not guarantee the success of any specific mass-production design.
- When the products described herein are regulated products subject to the Wassenaar Arrangement or other agreements, they may not be exported without authorization from the appropriate governmental authority.
- Use of the information described herein for other purposes and/or reproduction or copying without the express permission of Seiko Instruments Inc. is strictly prohibited.
- The products described herein cannot be used as part of any device or equipment affecting the human body, such as exercise equipment, medical equipment, security systems, gas equipment, vehicle equipment, in-vehicle equipment, aviation equipment, aerospace equipment, and nuclear-related equipment, without prior written permission of Seiko Instruments Inc.
- The products described herein are not designed to be radiation-proof.
- Although Seiko Instruments Inc. exerts the greatest possible effort to ensure high quality and reliability, the failure or malfunction of semiconductor products may occur. The user of these products should therefore give thorough consideration to safety design, including redundancy, fire-prevention measures, and malfunction prevention, to prevent any accidents, fires, or community damage that may ensue.