

SUPER-SMALL PACKAGE 2-CIRCUIT HIGH RIPPLE-REJECTION LOW DROPOUT CMOS VOLTAGE REGULATOR

www.sii-ic.com

© Seiko Instruments Inc., 2004-2010

Rev.3.0_00

The S-1711 Series is a 2-channel positive voltage regulator with a low dropout voltage, high output voltage accuracy, and low current consumption (150 mA output current) developed based on CMOS technology.

A 1.0 μ F small ceramic capacitor can be used, and a 2-circuit voltage regulator with $\pm 1.0\%$ high-accuracy output voltage is incorporated in an SOT-23-6 or super-small SNT-6A package. The A/ B/ E/ F types are provided with a discharge shunt function allowing high-speed output response when the ON/OFF pin is used.

Compared with the conventional 150 mA output current 2-channel CMOS voltage regulators, high-density mounting is realized by using the super-small SNT-6A package and a small ceramic capacitor. Also, the low current consumption makes the S-1711 Series ideal for mobile devices.

■ Features

- Output voltage: 1.5 V to 5.5 V, selectable in 0.1 V steps.
- Low ESR capacitor can be used: A ceramic capacitor of 1.0 μ F or more can be used for the output capacitor.
- Wide input voltage range: 2.0 V to 6.5 V
- High-accuracy output voltage: $\pm 1.0\%$
- Low dropout voltage: 200 mV typ. (3.0 V output product, $I_{OUT} = 150$ mA)
- Low current consumption: During operation: 70 μ A typ., 90 μ A max. (Per circuit)
During shutdown: 0.1 μ A typ., 1.0 μ A max.
- Output current: 150 mA output is possible (at $V_{IN} \geq V_{OUT(S)} + 1.0$ V)^{*1} (Per circuit)
- High ripple rejection: 70 dB typ. (at 1.0 kHz)
- Built-in overcurrent protector: Overcurrent of output transistor can be restricted.
- Built-in ON/OFF circuit: Ensures long battery life.
- Discharge shunt circuit can be selected.
- Pull-down or pull-down resistor can be selected.
- Lead-free, Sn 100%, halogen-free^{*2}

*1. Attention should be paid to the power dissipation of the package when the output current is large.

*2. Refer to "■ Product Name Structure" for details.

■ Applications

- Power supply for cellular phones
- Power supply for battery-powered devices
- Power supply for home electric/electronic appliances

■ Packages

- SNT-6A
- SNT-23-6

■ **Block Diagrams**

1. **S-1711 Series A type**

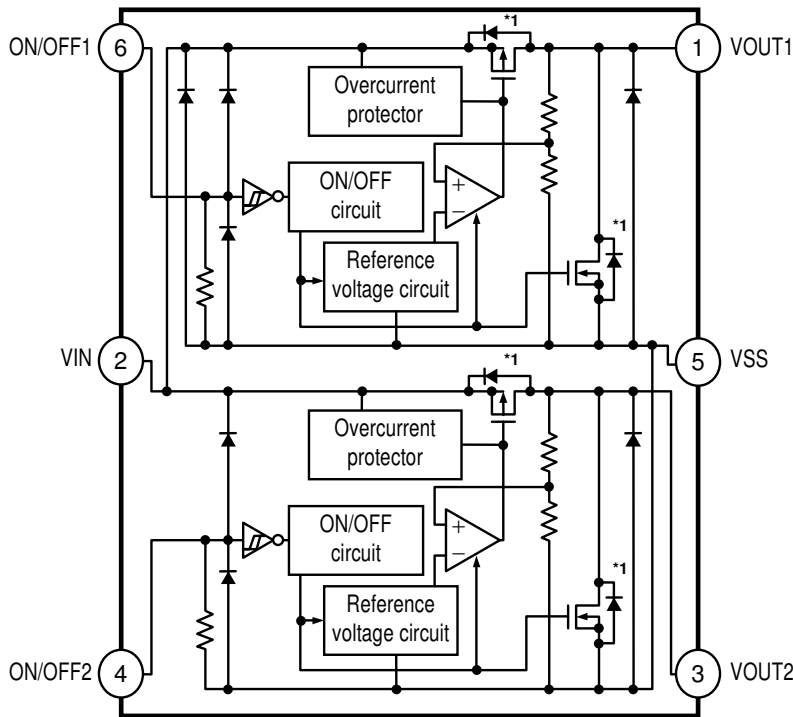

Function	Status
ON/OFF logic	Active "H"
Discharge shunt function	Available
Pull-up resistance	None
Pull-down resistance	Available

*1. Parasitic diode

Figure 1

2. **S-1711 Series B type**

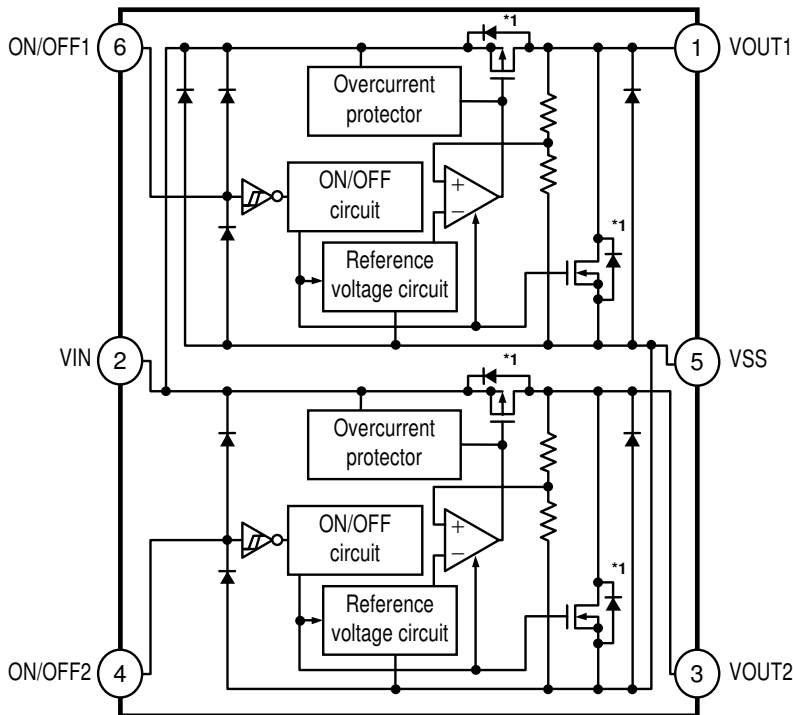

Function	Status
ON/OFF logic	Active "H"
Discharge shunt function	Available
Pull-up resistance	None
Pull-down resistance	None

*1. Parasitic diode

Figure 2

3. S-1711 Series C type

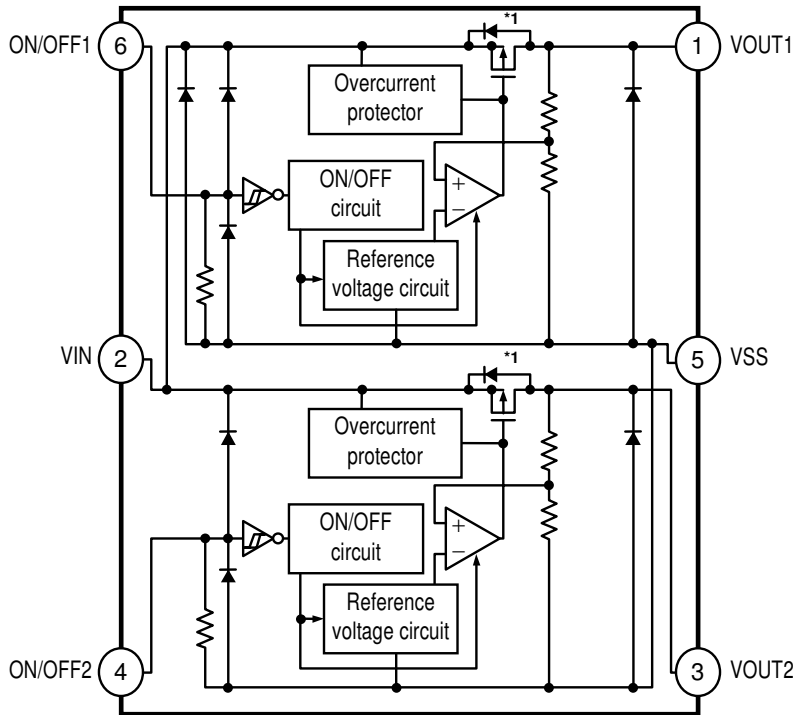

Function	Status
ON/OFF logic	Active "H"
Discharge shunt function	None
Pull-up resistance	None
Pull-down resistance	Available

*1. Parasitic diode

Figure 3

4. S-1711 Series D type

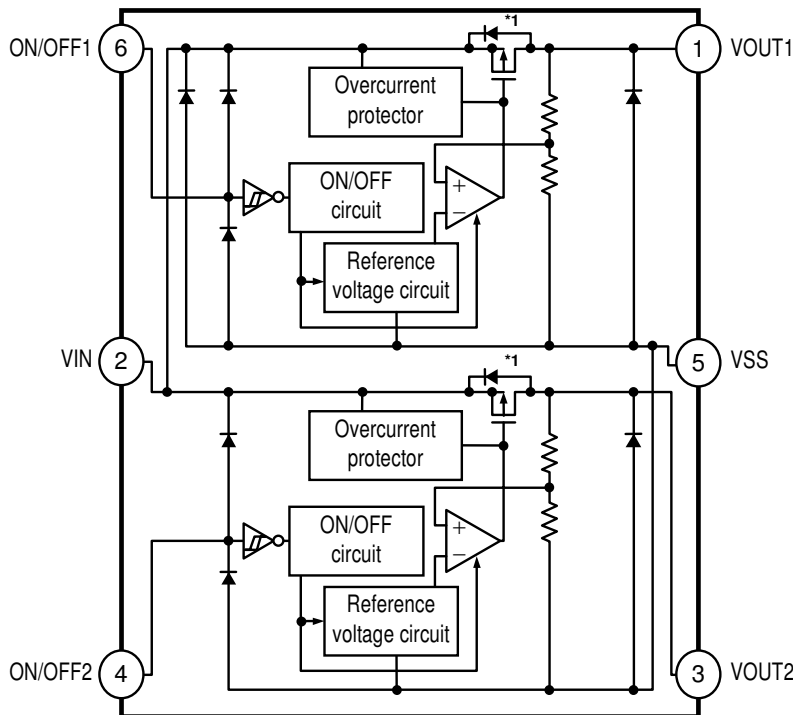

Function	Status
ON/OFF logic	Active "H"
Discharge shunt function	None
Pull-up resistance	None
Pull-down resistance	None

*1. Parasitic diode

Figure 4

5. S-1711 Series E type

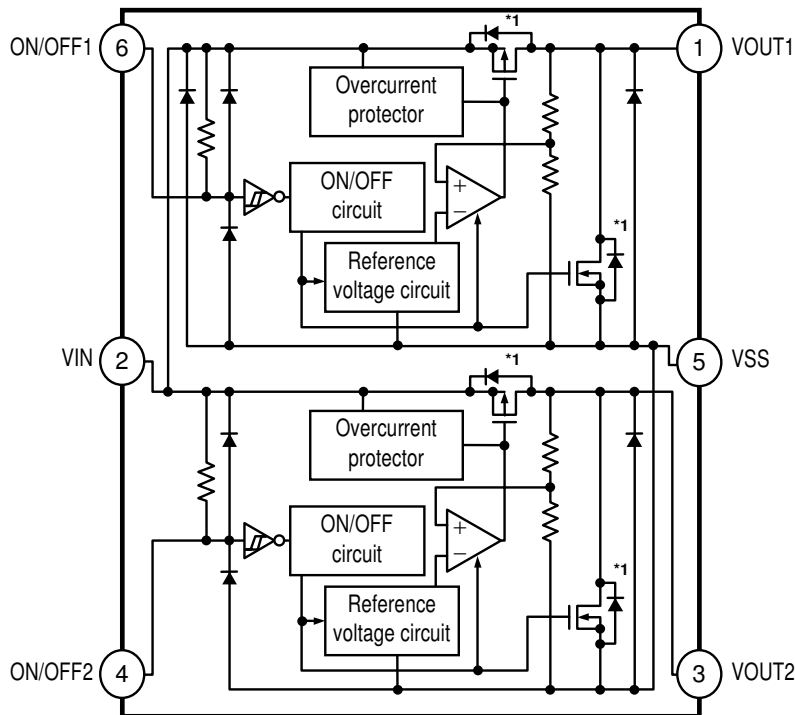

Function	Status
ON/OFF logic	Active "L"
Discharge shunt function	Available
Pull-up resistance	Available
Pull-down resistance	None

*1. Parasitic diode

Figure 5

6. S-1711 Series F type

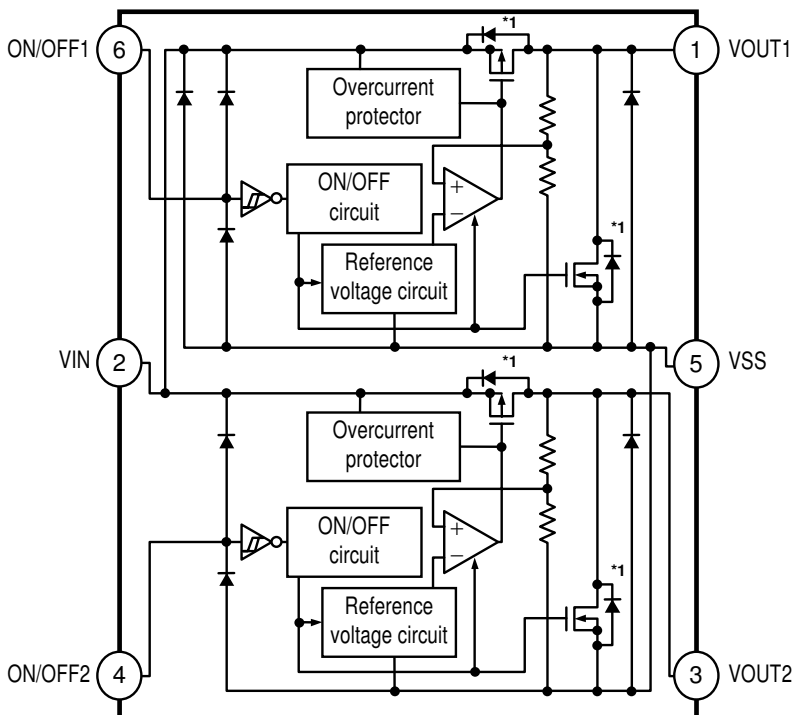

Function	Status
ON/OFF logic	Active "L"
Discharge shunt function	Available
Pull-up resistance	None
Pull-down resistance	None

*1. Parasitic diode

Figure 6

7. S-1711 Series G type

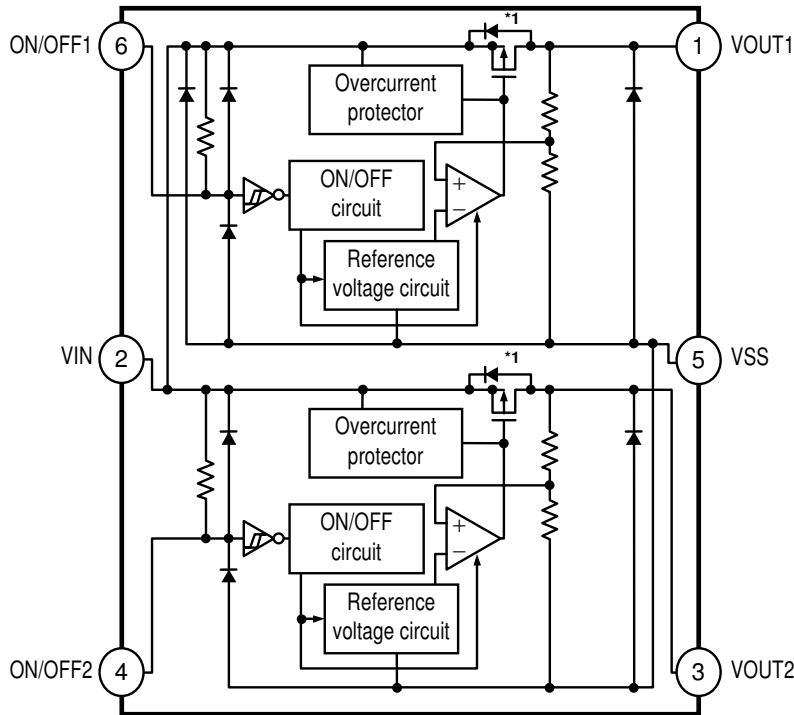

Function	Status
ON/OFF logic	Active "L"
Discharge shunt function	None
Pull-up resistance	Available
Pull-down resistance	None

*1. Parasitic diode

Figure 7

8. S-1711 Series H type

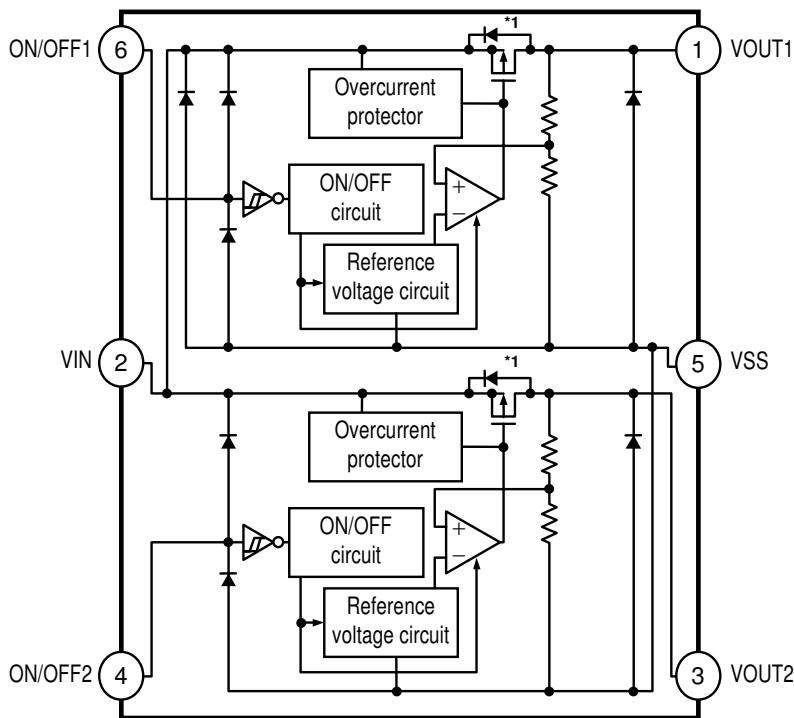

Function	Status
ON/OFF logic	Active "L"
Discharge shunt function	None
Pull-up resistance	None
Pull-down resistance	None

*1. Parasitic diode

Figure 8

■ Product Name Structure

- The product types, output voltage, and package types for the S-1711 Series can be selected at the user's request. Refer to the "1. Product name" for the meanings of the characters in the product name, "2. Function list according to product type" for product types, "3. Package" regarding the package drawings and "4. Product name list" regarding details of product name.

1. Product name

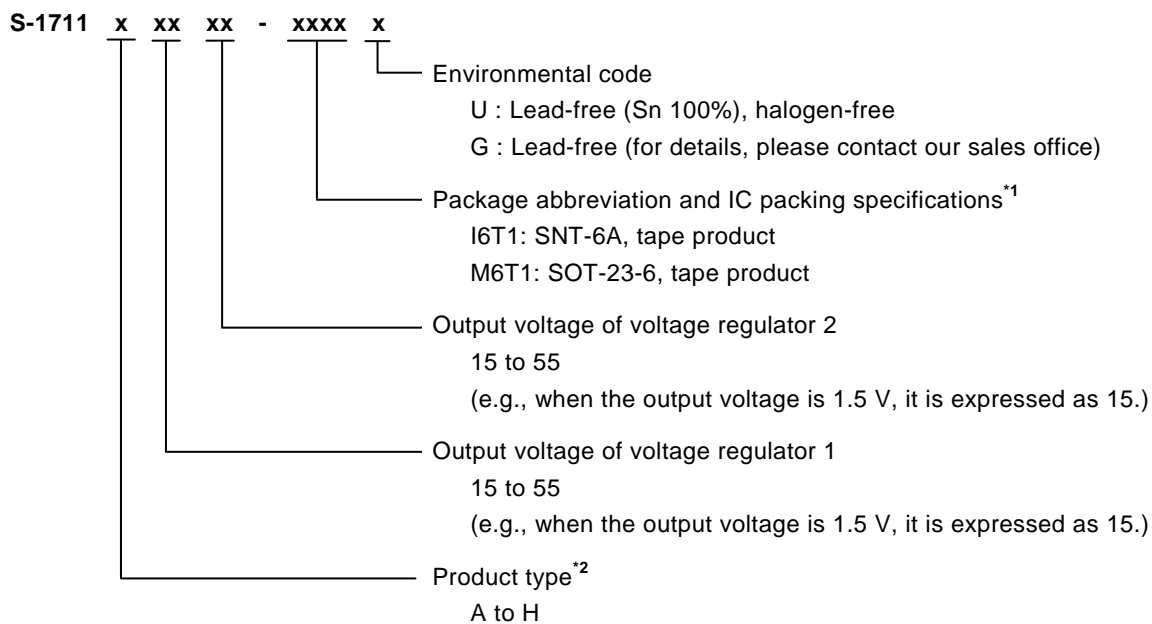

*1. Refer to the tape specifications at the end of this book.

*2. Refer to the "2. Function list according to product type".

2. Function list according to product type

Table 1

Product Type	ON/OFF Logic	Discharge Shunt Function	Pull-up Resistance	Pull-down Resistance
A	Active high	Available	None	Available
B	Active high	Available	None	None
C	Active high	None	None	Available
D	Active high	None	None	None
E	Active low	Available	Available	None
F	Active low	Available	None	None
G	Active low	None	Available	None
H	Active low	None	None	None

3. Package

Package Name	Drawing Code			
	Package	Tape	Reel	Land
SNT-6A	PG006-A-P-SD	PG006-A-C-SD	PG006-A-R-SD	PG006-A-L-SD
SOT-23-6	MP006-A-P-SD	MP006-A-C-SD	MP006-A-R-SD	—

4. Product name list

4.1 S-1711 Series A type

ON/OFF logic: Active high Pull-up Resistance: None
 Discharge Shunt Function: Available Pull-down Resistance: Available

Table 2 (1 / 2)

Voltage Regulator1 Output Voltage	Voltage Regulator2 Output Voltage	SNT-6A	SOT-23-6
1.5 V ±1.0%	1.5 V ±1.0%	S-1711A1515-I6T1x	S-1711A1515-M6T1x
1.5 V ±1.0%	1.8 V ±1.0%	S-1711A1518-I6T1x	—
1.5 V ±1.0%	2.6 V ±1.0%	S-1711A1526-I6T1x	—
1.5 V ±1.0%	2.8 V ±1.0%	S-1711A1528-I6T1x	S-1711A1528-M6T1x
1.5 V ±1.0%	2.85 V ±1.0%	S-1711A152J-I6T1x	—
1.5 V ±1.0%	2.9 V ±1.0%	—	S-1711A1529-M6T1x
1.5 V ±1.0%	3.3 V ±1.0%	S-1711A1533-I6T1x	S-1711A1533-M6T1x
1.8 V ±1.0%	1.5 V ±1.0%	S-1711A1815-I6T1x	S-1711A1815-M6T1x
1.8 V ±1.0%	1.8 V ±1.0%	S-1711A1818-I6T1x	S-1711A1818-M6T1x
1.8 V ±1.0%	2.5 V ±1.0%	—	S-1711A1825-M6T1x
1.8 V ±1.0%	2.7 V ±1.0%	S-1711A1827-I6T1x	S-1711A1827-M6T1x
1.8 V ±1.0%	2.75 V ±1.0%	S-1711A182H-I6T1x	S-1711A182H-M6T1x
1.8 V ±1.0%	2.8 V ±1.0%	S-1711A1828-I6T1x	S-1711A1828-M6T1x
1.8 V ±1.0%	2.85 V ±1.0%	S-1711A182J-I6T1x	S-1711A182J-M6T1x
1.8 V ±1.0%	2.9 V ±1.0%	S-1711A1829-I6T1x	S-1711A1829-M6T1x
1.8 V ±1.0%	3.0 V ±1.0%	S-1711A1830-I6T1x	S-1711A1830-M6T1x
1.8 V ±1.0%	3.2 V ±1.0%	—	S-1711A1832-M6T1x
1.8 V ±1.0%	3.3 V ±1.0%	S-1711A1833-I6T1x	S-1711A1833-M6T1x
1.85 V ±1.0%	2.8 V ±1.0%	S-1711A1J28-I6T1x	S-1711A1J28-M6T1x
2.0 V ±1.0%	4.5 V ±1.0%	—	S-1711A2045-M6T1x
2.3 V ±1.0%	3.2 V ±1.0%	S-1711A2332-I6T1x	—
2.3 V ±1.0%	3.3 V ±1.0%	S-1711A2333-I6T1x	—
2.4 V ±1.0%	2.4 V ±1.0%	S-1711A2424-I6T1x	S-1711A2424-M6T1x
2.4 V ±1.0%	2.5 V ±1.0%	S-1711A2425-I6T1x	S-1711A2425-M6T1x
2.5 V ±1.0%	1.5 V ±1.0%	S-1711A2515-I6T1x	S-1711A2515-M6T1x
2.5 V ±1.0%	1.8 V ±1.0%	S-1711A2518-I6T1x	S-1711A2518-M6T1x
2.5 V ±1.0%	2.2 V ±1.0%	—	S-1711A2522-M6T1x
2.5 V ±1.0%	2.5 V ±1.0%	S-1711A2525-I6T1x	S-1711A2525-M6T1x
2.5 V ±1.0%	2.8 V ±1.0%	S-1711A2528-I6T1x	S-1711A2528-M6T1x
2.5 V ±1.0%	2.9 V ±1.0%	—	S-1711A2529-M6T1x
2.5 V ±1.0%	3.3 V ±1.0%	S-1711A2533-I6T1x	S-1711A2533-M6T1x
2.6 V ±1.0%	1.8 V ±1.0%	—	S-1711A2618-M6T1x
2.6 V ±1.0%	2.6 V ±1.0%	S-1711A2626-I6T1x	—
2.6 V ±1.0%	2.8 V ±1.0%	S-1711A2628-I6T1x	—
2.6 V ±1.0%	2.9 V ±1.0%	S-1711A2629-I6T1x	—
2.6 V ±1.0%	3.0 V ±1.0%	S-1711A2630-I6T1x	—
2.7 V ±1.0%	1.8 V ±1.0%	—	S-1711A2718-M6T1x
2.8 V ±1.0%	1.5 V ±1.0%	S-1711A2815-I6T1x	S-1711A2815-M6T1x
2.8 V ±1.0%	1.8 V ±1.0%	S-1711A2818-I6T1x	S-1711A2818-M6T1x
2.8 V ±1.0%	1.9 V ±1.0%	—	S-1711A2819-M6T1x
2.8 V ±1.0%	2.5 V ±1.0%	—	S-1711A2825-M6T1x

Table 2 (2 / 2)

Voltage Regulator1 Output Voltage	Voltage Regulator2 Output Voltage	SNT-6A	SOT-23-6
2.8 V ±1.0%	2.8 V ±1.0%	S-1711A2828-I6T1x	S-1711A2828-M6T1x
2.8 V ±1.0%	2.9 V ±1.0%	S-1711A2829-I6T1x	S-1711A2829-M6T1x
2.8 V ±1.0%	3.0 V ±1.0%	S-1711A2830-I6T1x	S-1711A2830-M6T1x
2.8 V ±1.0%	3.1 V ±1.0%	S-1711A2831-I6T1x	—
2.8 V ±1.0%	3.2 V ±1.0%	S-1711A2832-I6T1x	S-1711A2832-M6T1x
2.8 V ±1.0%	3.3 V ±1.0%	S-1711A2833-I6T1x	S-1711A2833-M6T1x
2.85 V ±1.0%	1.5 V ±1.0%	S-1711A2J15-I6T1x	—
2.85 V ±1.0%	1.8 V ±1.0%	S-1711A2J18-I6T1x	—
2.85 V ±1.0%	2.85 V ±1.0%	S-1711A2J2J-I6T1x	S-1711A2J2J-M6T1x
2.85 V ±1.0%	3.0 V ±1.0%	—	S-1711A2J30-M6T1x
2.85 V ±1.0%	3.3 V ±1.0%	S-1711A2J33-I6T1x	—
2.9 V ±1.0%	2.9 V ±1.0%	S-1711A2929-I6T1x	S-1711A2929-M6T1x
2.9 V ±1.0%	3.3 V ±1.0%	—	S-1711A2933-M6T1x
3.0 V ±1.0%	1.5 V ±1.0%	S-1711A3015-I6T1x	S-1711A3015-M6T1x
3.0 V ±1.0%	1.8 V ±1.0%	S-1711A3018-I6T1x	S-1711A3018-M6T1x
3.0 V ±1.0%	2.5 V ±1.0%	S-1711A3025-I6T1x	S-1711A3025-M6T1x
3.0 V ±1.0%	2.8 V ±1.0%	S-1711A3028-I6T1x	—
3.0 V ±1.0%	3.0 V ±1.0%	S-1711A3030-I6T1x	S-1711A3030-M6T1x
3.0 V ±1.0%	3.3 V ±1.0%	S-1711A3033-I6T1x	S-1711A3033-M6T1x
3.1 V ±1.0%	2.8 V ±1.0%	S-1711A3128-I6T1x	—
3.3 V ±1.0%	1.8 V ±1.0%	S-1711A3318-I6T1x	—
3.3 V ±1.0%	2.5 V ±1.0%	—	S-1711A3325-M6T1x
3.3 V ±1.0%	2.8 V ±1.0%	—	S-1711A3328-M6T1x
3.3 V ±1.0%	3.0 V ±1.0%	—	S-1711A3330-M6T1x
3.3 V ±1.0%	3.3 V ±1.0%	S-1711A3333-I6T1x	S-1711A3333-M6T1x
3.3 V ±1.0%	4.8 V ±1.0%	S-1711A3348-I6T1x	S-1711A3348-M6T1x
3.3 V ±1.0%	5.0 V ±1.0%	S-1711A3350-I6T1x	—
3.4 V ±1.0%	3.4 V ±1.0%	S-1711A3434-I6T1x	—
4.0 V ±1.0%	2.0 V ±1.0%	—	S-1711A4020-M6T1x
5.0 V ±1.0%	2.5 V ±1.0%	S-1711A5025-I6T1x	S-1711A5025-M6T1x
5.0 V ±1.0%	3.0 V ±1.0%	S-1711A5030-I6T1x	—

- Remark 1.** Please contact the SII marketing department for products with specifications other than the above.
2. x: G or U
 3. Please select products of environmental code = U for Sn 100%, halogen-free products.

4.2 S-1711 Series B type

ON/OFF logic: Active high Pull-up Resistance: None
 Discharge Shunt Function: Available Pull-down Resistance: None

Table 3

Voltage Regulator1 Output Voltage	Voltage Regulator2 Output Voltage	SNT-6A	SOT-23-6
1.5 V ±1.0%	1.8 V ±1.0%	S-1711B1518-I6T1x	S-1711B1518-M6T1x
1.5 V ±1.0%	2.8 V ±1.0%	S-1711B1528-I6T1x	—
1.5 V ±1.0%	2.9 V ±1.0%	—	S-1711B1529-M6T1x
1.8 V ±1.0%	2.5 V ±1.0%	S-1711B1825-I6T1x	S-1711B1825-M6T1x
1.8 V ±1.0%	2.8 V ±1.0%	S-1711B1828-I6T1x	S-1711B1828-M6T1x
1.8 V ±1.0%	3.2 V ±1.0%	—	S-1711B1832-M6T1x
1.8 V ±1.0%	3.3 V ±1.0%	S-1711B1833-I6T1x	S-1711B1833-M6T1x
2.5 V ±1.0%	1.5 V ±1.0%	—	S-1711B2515-M6T1x
2.5 V ±1.0%	1.8 V ±1.0%	S-1711B2518-I6T1x	S-1711B2518-M6T1x
2.5 V ±1.0%	2.8 V ±1.0%	S-1711B2528-I6T1x	S-1711B2528-M6T1x
2.6 V ±1.0%	1.8 V ±1.0%	—	S-1711B2618-M6T1x
2.7 V ±1.0%	1.8 V ±1.0%	—	S-1711B2718-M6T1x
2.8 V ±1.0%	1.5 V ±1.0%	S-1711B2815-I6T1x	S-1711B2815-M6T1x
2.8 V ±1.0%	1.8 V ±1.0%	S-1711B2818-I6T1x	S-1711B2818-M6T1x
2.8 V ±1.0%	2.5 V ±1.0%	—	S-1711B2825-M6T1x
2.8 V ±1.0%	2.8 V ±1.0%	S-1711B2828-I6T1x	S-1711B2828-M6T1x
2.8 V ±1.0%	3.3 V ±1.0%	S-1711B2833-I6T1x	—
3.0 V ±1.0%	3.0 V ±1.0%	—	S-1711B3030-M6T1x
3.0 V ±1.0%	3.3 V ±1.0%	S-1711B3033-I6T1x	S-1711B3033-M6T1x
3.0 V ±1.0%	3.6 V ±1.0%	—	S-1711B3036-M6T1x
3.3 V ±1.0%	3.3 V ±1.0%	S-1711B3333-I6T1x	S-1711B3333-M6T1x

- Remark 1.** Please contact the SII marketing department for products with specifications other than the above.
2. x: G or U
3. Please select products of environmental code = U for Sn 100%, halogen-free products.

4.3 S-1711 Series C type

ON/OFF logic: Active high Pull-up Resistance: None
 Discharge Shunt Function: None Pull-down Resistance: Available

Table 4

Voltage Regulator1 Output Voltage	Voltage Regulator2 Output Voltage	SNT-6A	SOT-23-6
1.5 V ±1.0%	1.5 V ±1.0%	S-1711C1515-I6T1x	S-1711C1515-M6T1x
1.8 V ±1.0%	1.5 V ±1.0%	S-1711C1815-I6T1x	S-1711C1815-M6T1x
1.8 V ±1.0%	2.5 V ±1.0%	—	S-1711C1825-M6T1x
1.8 V ±1.0%	2.7 V ±1.0%	S-1711C1827-I6T1x	S-1711C1827-M6T1x
1.8 V ±1.0%	2.75 V ±1.0%	S-1711C182H-I6T1x	S-1711C182H-M6T1x
1.8 V ±1.0%	2.8 V ±1.0%	S-1711C1828-I6T1x	—
1.8 V ±1.0%	3.2 V ±1.0%	—	S-1711C1832-M6T1x
1.85 V ±1.0%	2.8 V ±1.0%	S-1711C1J28-I6T1x	S-1711C1J28-M6T1x
2.4 V ±1.0%	2.4 V ±1.0%	S-1711C2424-I6T1x	S-1711C2424-M6T1x
2.4 V ±1.0%	2.5 V ±1.0%	S-1711C2425-I6T1x	S-1711C2425-M6T1x
2.5 V ±1.0%	1.5 V ±1.0%	S-1711C2515-I6T1x	S-1711C2515-M6T1x
2.5 V ±1.0%	1.8 V ±1.0%	S-1711C2518-I6T1x	S-1711C2518-M6T1x
2.5 V ±1.0%	2.5 V ±1.0%	S-1711C2525-I6T1x	S-1711C2525-M6T1x
2.8 V ±1.0%	1.5 V ±1.0%	S-1711C2815-I6T1x	S-1711C2815-M6T1x
2.8 V ±1.0%	1.8 V ±1.0%	S-1711C2818-I6T1x	S-1711C2818-M6T1x
2.8 V ±1.0%	2.8 V ±1.0%	S-1711C2828-I6T1x	S-1711C2828-M6T1x
2.8 V ±1.0%	2.9 V ±1.0%	S-1711C2829-I6T1x	S-1711C2829-M6T1x
2.8 V ±1.0%	3.0 V ±1.0%	S-1711C2830-I6T1x	S-1711C2830-M6T1x
2.8 V ±1.0%	3.3 V ±1.0%	S-1711C2833-I6T1x	S-1711C2833-M6T1x
2.85 V ±1.0%	2.85 V ±1.0%	S-1711C2J2J-I6T1x	S-1711C2J2J-M6T1x
2.9 V ±1.0%	2.9 V ±1.0%	S-1711C2929-I6T1x	S-1711C2929-M6T1x
3.0 V ±1.0%	1.5 V ±1.0%	S-1711C3015-I6T1x	S-1711C3015-M6T1x
3.0 V ±1.0%	1.8 V ±1.0%	S-1711C3018-I6T1x	S-1711C3018-M6T1x
3.0 V ±1.0%	2.5 V ±1.0%	S-1711C3025-I6T1x	S-1711C3025-M6T1x
3.0 V ±1.0%	3.0 V ±1.0%	S-1711C3030-I6T1x	S-1711C3030-M6T1x
3.0 V ±1.0%	3.3 V ±1.0%	S-1711C3033-I6T1x	S-1711C3033-M6T1x
3.1 V ±1.0%	3.1 V ±1.0%	—	S-1711C3131-M6T1x

- Remark 1.** Please contact the SII marketing department for products with specifications other than the above.
- 2.** x: G or U
 - 3.** Please select products of environmental code = U for Sn 100%, halogen-free products.

4.4 S-1711 Series D type

ON/OFF logic: Active high Pull-up Resistance: None
 Discharge Shunt Function: None Pull-down Resistance: None

Table 5

Voltage Regulator1 Output Voltage	Voltage Regulator2 Output Voltage	SNT-6A	SOT-23-6
1.8 V \pm 1.0%	2.5 V \pm 1.0%	—	S-1711D1825-M6T1x
1.8 V \pm 1.0%	2.6 V \pm 1.0%	—	S-1711D1826-M6T1x
1.8 V \pm 1.0%	2.8 V \pm 1.0%	S-1711D1828-I6T1x	S-1711D1828-M6T1x
1.8 V \pm 1.0%	3.2 V \pm 1.0%	—	S-1711D1832-M6T1x
1.9 V \pm 1.0%	2.5 V \pm 1.0%	S-1711D1925-I6T1x	S-1711D1925-M6T1x
2.5 V \pm 1.0%	1.8 V \pm 1.0%	S-1711D2518-I6T1x	S-1711D2518-M6T1x
2.5 V \pm 1.0%	2.8 V \pm 1.0%	S-1711D2528-I6T1x	S-1711D2528-M6T1x
2.5 V \pm 1.0%	2.85 V \pm 1.0%	S-1711D252J-I6T1x	—
2.6 V \pm 1.0%	2.9 V \pm 1.0%	—	S-1711D2629-M6T1x
2.8 V \pm 1.0%	1.5 V \pm 1.0%	S-1711D2815-I6T1x	S-1711D2815-M6T1x
2.85 V \pm 1.0%	2.85 V \pm 1.0%	S-1711D2J2J-I6T1x	—
4.2 V \pm 1.0%	3.0 V \pm 1.0%	—	S-1711D4230-M6T1x

4.5 S-1711 Series E type

ON/OFF logic: Active low Pull-up Resistance: Available
 Discharge Shunt Function: Available Pull-down Resistance: None

Table 6

Voltage Regulator1 Output Voltage	Voltage Regulator2 Output Voltage	SNT-6A	SOT-23-6
1.8 V \pm 1.0%	3.3 V \pm 1.0%	—	S-1711E1833-M6T1x
2.8 V \pm 1.0%	1.8 V \pm 1.0%	S-1711E2818-I6T1x	S-1711E2818-M6T1x
3.3 V \pm 1.0%	3.3 V \pm 1.0%	—	S-1711E3333-M6T1x

4.6 S-1711 Series F type

ON/OFF logic: Active low Pull-up Resistance: None
 Discharge Shunt Function: Available Pull-down Resistance: None

Table 7

Voltage Regulator1 Output Voltage	Voltage Regulator2 Output Voltage	SNT-6A	SOT-23-6
2.8 V \pm 1.0%	1.8 V \pm 1.0%	S-1711F2818-I6T1x	—

- Remark 1.** Please contact the SII marketing department for products with specifications other than the above.
2. x: G or U
3. Please select products of environmental code = U for Sn 100%, halogen-free products.

4.7 S-1711 Series G type

ON/OFF logic: Active low Pull-up Resistance: Available
 Discharge Shunt Function: None Pull-down Resistance: None

Table 8

Voltage Regulator1 Output Voltage	Voltage Regulator2 Output Voltage	SNT-6A	SOT-23-6
2.8 V ±1.0%	3.0 V ±1.0%	S-1711G2830-I6T1x	—

4.8 S-1711 Series H type

ON/OFF logic: Active low Pull-up Resistance: None
 Discharge Shunt Function: None Pull-down Resistance: None

Table 9

Voltage Regulator1 Output Voltage	Voltage Regulator2 Output Voltage	SNT-6A	SOT-23-6
2.5 V ±1.0%	1.8 V ±1.0%	—	S-1711H2518-M6T1x

- Remark 1.** Please contact the SII marketing department for products with specifications other than the above.
2. x: G or U
 3. Please select products of environmental code = U for Sn 100%, halogen-free products.

■ Pin Configurations

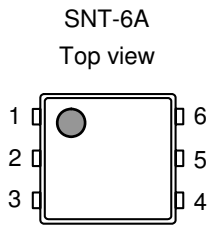

Figure 9

Table 10

Pin No.	Symbol	Description
1	VOUT1	Output voltage pin 1
2	VIN	Input voltage pin
3	VOUT2	Output voltage pin 2
4	ON/OFF2	ON/OFF pin 2
5	VSS	GND pin
6	ON/OFF1	ON/OFF pin 1

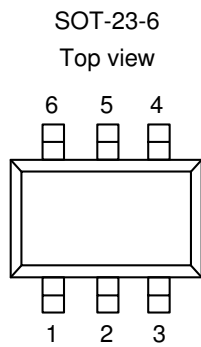

Figure 10

Table 11

Pin No.	Symbol	Description
1	VOUT1	Output voltage pin 1
2	VIN	Input voltage pin
3	VOUT2	Output voltage pin 2
4	ON/OFF2	ON/OFF pin 2
5	VSS	GND pin
6	ON/OFF1	ON/OFF pin 1

■ Absolute Maximum Ratings

Table 12

(Ta = 25°C unless otherwise specified)

Item		Symbol	Absolute Maximum Rating	Unit
Input voltage		V_{IN}	$V_{SS}-0.3 \sim V_{SS}+7$	V
		$V_{ON/OFF1,2}$	$V_{SS}-0.3 \sim V_{IN}+0.3$	V
Output voltage		$V_{OUT1,2}$	$V_{SS}-0.3 \sim V_{IN}+0.3$	V
Power dissipation	SNT-6A	P_D	400^{*1}	mW
	SOT-23-6		300 (When not mounted on board)	mW
			650^{*1}	mW
Operating ambient temperature		T_{opr}	-40 ~ +85	°C
Storage temperature		T_{stg}	-40 ~ +125	°C

*1. When mounted on board

[Mounted board]

- (1) Board size: 114.3 mm × 76.2 mm × 1.6 mm
- (2) Name: JEDEC STANDARD51-7

Caution The absolute maximum ratings are rated values exceeding which the product could suffer physical damage. These values must therefore not be exceeded under any conditions.

(1) When mounted on board

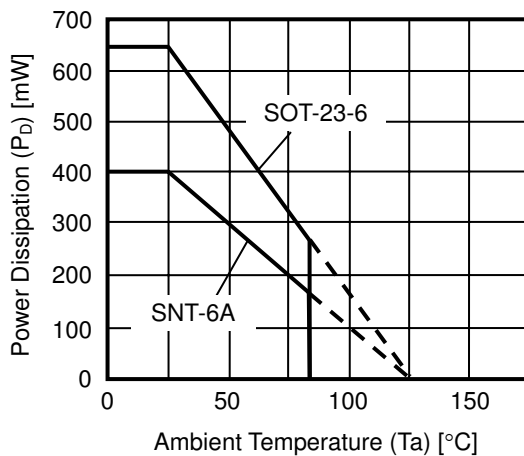

(2) When not mounted on board

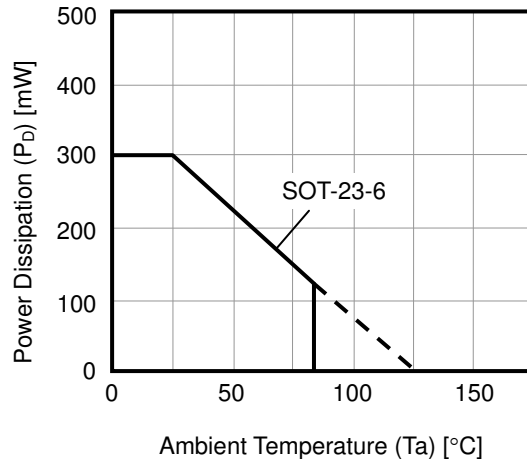

Figure 11 Power Dissipation of Package

■ **Electrical Characteristics**

Table 13

Total (2 circuits) (Ta = 25°C unless otherwise specified)

Item	Symbol	Conditions	Min.	Typ.	Max.	Unit	Test Circuit
Current consumption	I _{SS}	V _{IN} = 6.5 V, no load	—	140	180	μA	1

Voltage regulator 1 or Voltage regulator 2 (Par circuits) (Ta = 25°C unless otherwise specified)

Item	Symbol	Conditions	Min.	Typ.	Max.	Unit	Test Circuit	
Output voltage ^{*1}	V _{OUT(E)}	V _{IN} = V _{OUT(S)} + 1.0 V, I _{OUT} = 30 mA	V _{OUT(S)} × 0.99	V _{OUT(S)}	V _{OUT(S)} × 1.01	V	2, 3	
Output current ^{*2}	I _{OUT}	V _{IN} ≥ V _{OUT(S)} + 1.0 V	150 ^{*5}	—	—	mA	4, 5	
Dropout voltage ^{*3}	V _{drop}	I _{OUT} = 150 mA	V _{OUT(S)} = 1.5 V	0.50	0.54	0.58	V	2, 3
			V _{OUT(S)} = 1.6 V	0.40	0.44	0.48	V	2, 3
			V _{OUT(S)} = 1.7 V	0.30	0.34	0.39	V	2, 3
			1.8 V ≤ V _{OUT(S)} ≤ 2.0 V	0.20	0.26	0.39	V	2, 3
			2.1 V ≤ V _{OUT(S)} ≤ 2.7 V	—	0.24	0.36	V	2, 3
			2.8 V ≤ V _{OUT(S)} ≤ 5.5 V	—	0.20	0.35	V	2, 3
Line regulation	$\frac{\Delta V_{OUT1}}{\Delta V_{IN} \cdot V_{OUT}}$	V _{OUT(S)} + 0.5 V ≤ V _{IN} ≤ 6.5 V, I _{OUT} = 30 mA	—	0.02	0.1	% / V	2, 3	
Load regulation	ΔV_{OUT2}	V _{IN} = V _{OUT(S)} + 1.0 V, 1.0 mA ≤ I _{OUT} ≤ 150 mA	—	20	40	mV	2, 3	
Output voltage temperature coefficient ^{*4}	$\frac{\Delta V_{OUT}}{\Delta T_a \cdot V_{OUT}}$	V _{IN} = V _{OUT(S)} + 1.0 V, I _{OUT} = 30 mA, -40 ≤ Ta ≤ 85°C	—	±100	—	ppm / °C	2, 3	
Current consumption during operation	I _{SS1}	V _{IN} = V _{OUT(S)} + 1.0 V, ON/OFF pin = ON, no load	—	70	90	μA	1	
Current consumption during shutdown	I _{SS2}	V _{IN} = V _{OUT(S)} + 1.0 V, ON/OFF pin = OFF, no load	—	0.1	1.0	μA	1	
Input voltage	V _{IN}	—	2.0	—	6.5	V	1	
ON/OFF pin input voltage "H"	V _{SH}	V _{IN} = V _{OUT(S)} + 1.0 V, R _L = 1.0 kΩ	1.5	—	—	V	6, 7	
ON/OFF pin input voltage "L"	V _{SL}	V _{IN} = V _{OUT(S)} + 1.0 V, R _L = 1.0 kΩ	—	—	0.3	V	6, 7	
ON/OFF pin input current "H"	I _{SH}	V _{IN} = 6.5 V, V _{ON/OFF} = 6.5 V	A/ C type	1.0	2.5	4.2	μA	6, 7
			B/ D/ E/ F/ G/ H type	-0.1	—	0.1	μA	
ON/OFF pin input current "L"	I _{SL}	V _{IN} = 6.5 V, V _{ON/OFF} = 0 V	E/ G type	1.0	2.5	4.2	μA	6, 7
			A/ B/ C/ D/ F/ H type	-0.1	—	0.1	μA	
Ripple rejection	RR	V _{IN} = V _{OUT(S)} + 1.0 V, f = 1.0 kHz, ΔV _{rip} = 0.5 V _{rms} , I _{OUT} = 30 mA	—	70	—	dB	8, 9	
Short-circuit current	I _{short}	V _{IN} = V _{OUT(S)} + 1.0 V, ON/OFF pin = ON, V _{OUT} = 0 V	—	170	—	mA	4, 5	

S-1711 Series A/B/E/F type (Built-in discharge shunt function)

Item	Symbol	Conditions	Min.	Typ.	Max.	Unit	Test Circuit
"L" output Nch ON resistance	R _{LOW}	V _{OUT} = 0.1 V, V _{IN} = 6.5 V	—	100	—	Ω	4, 5

S-1711 Series A/C/E/G type (Built-in pull-up/pull-down resistance)

Item	Symbol	Conditions	Min.	Typ.	Max.	Unit	Test Circuit
Shutdown pull-up/pull-down resistance	R _{PD}	—	1.0	2.6	5.0	MΩ	6, 7

- *1. $V_{OUT(S)}$: Specified output voltage
 $V_{OUT(E)}$: Actual output voltage at the fixed load
 The output voltage when fixing $I_{OUT}(=30\text{ mA})$ and inputting $V_{OUT(S)} + 1.0\text{ V}$
- *2. The output current at which the output voltage becomes 95% of $V_{OUT(E)}$ after gradually increasing the output current.
- *3. $V_{drop} = V_{IN1} - (V_{OUT3} \times 0.98)$
 V_{OUT3} is the output voltage when $V_{IN} = V_{OUT(S)} + 1.0\text{ V}$ and $I_{OUT} = 150\text{ mA}$.
 V_{IN1} is the input voltage at which the output voltage becomes 98% of V_{OUT3} after gradually decreasing the input voltage.
- *4. The change in temperature [$\text{mV}/^\circ\text{C}$] is calculated using the following equation.

$$\frac{\Delta V_{OUT}}{\Delta T_a} [\text{mV}/^\circ\text{C}]^1 = V_{OUT(S)} [\text{V}]^2 \times \frac{\Delta V_{OUT}}{\Delta T_a \bullet V_{OUT}} [\text{ppm}/^\circ\text{C}]^3 \div 1000$$
 - *1. The change in temperature of the output voltage
 - *2. Specified output voltage
 - *3. Output voltage temperature coefficient
- *5. The output current can be at least this value.
 Due to restrictions on the package power dissipation, this value may not be satisfied. Attention should be paid to the power dissipation of the package when the output current is large.
 This specification is guaranteed by design.

■ Test Circuits

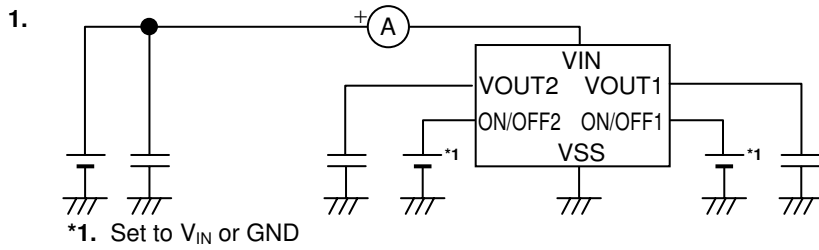

Figure 12

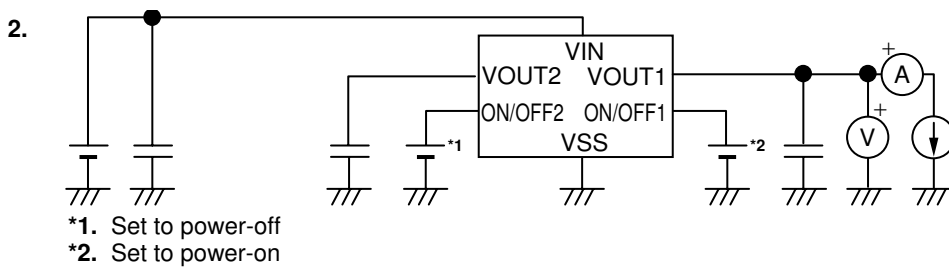

Figure 13

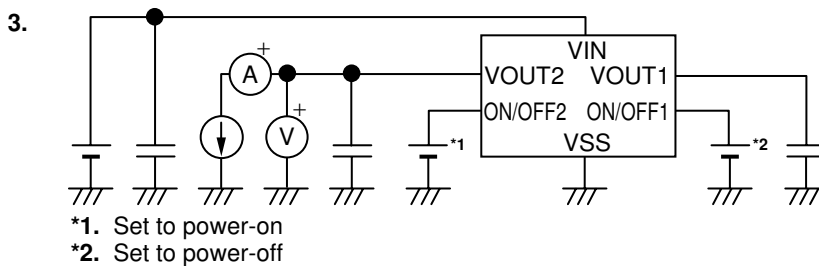

Figure 14

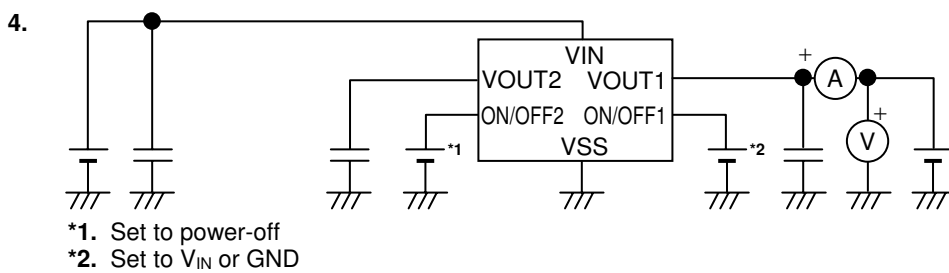

Figure 15

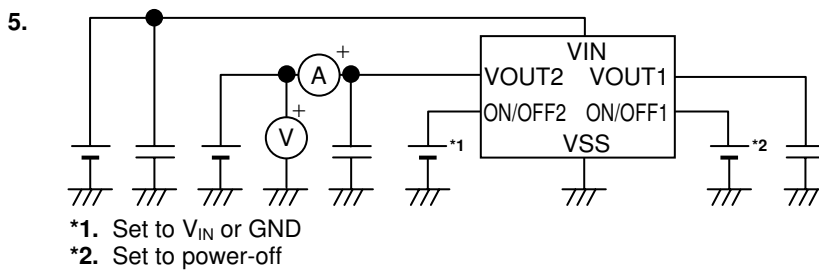

Figure 16

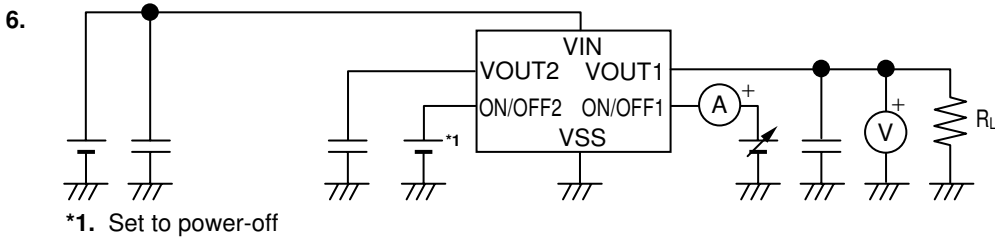

Figure 17

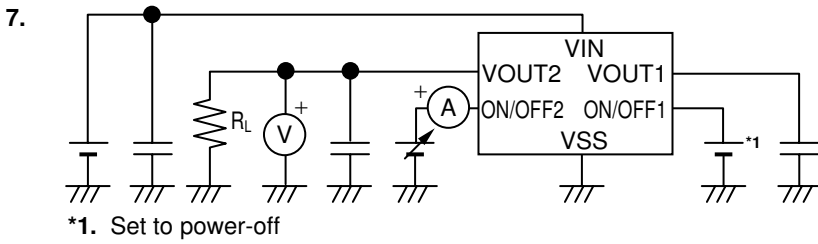

Figure 18

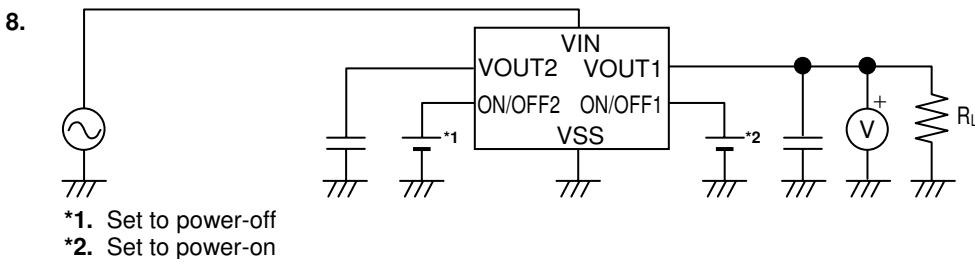

Figure 19

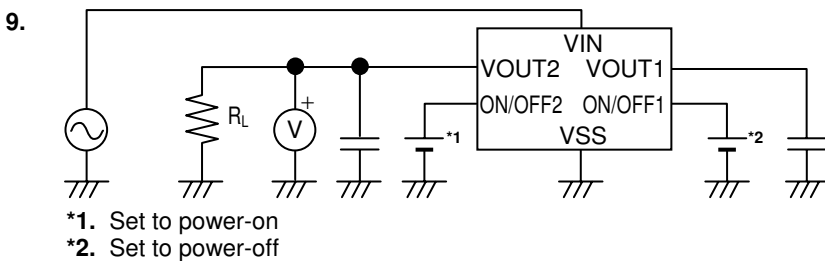
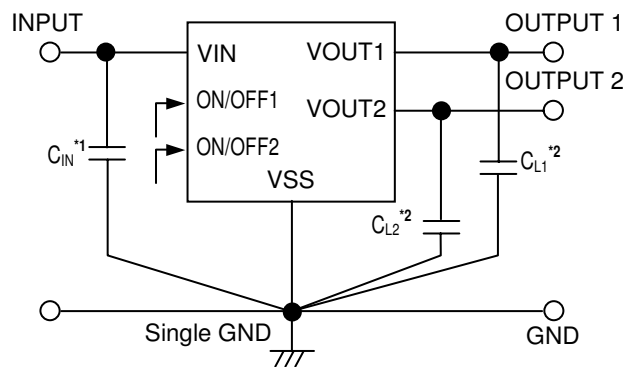

Figure 20

■ Standard Circuit



- *1. C_{IN} is a capacitor for stabilizing the input.
- *2. A ceramic capacitor of 1.0 μF or more can be used for C_{L1} and C_{L2} .

Figure 21

Caution The above connection diagram and constant will not guarantee successful operation. Perform thorough evaluation using the actual application to set the constant.

■ Application Conditions

- Input capacitor (C_{IN}): 1.0 μF or more
- Output capacitor (C_{L1}, C_{L2}): 1.0 μF or more
- ESR of output capacitor: 1.0 Ω or less

Caution A general series regulator may oscillate, depending on the external components selected. Check that no oscillation occurs with the application using the above capacitor. Use input/output capacitor which has good temperature characteristics (conforming to the ceramic capacitor EIA X5R (JIS B) characteristics).

■ Selection of Input and Output Capacitors (C_{IN}, C_{L1}, C_{L2})

The S-1711 Series requires an output capacitor between the VOUT and VSS pins for phase compensation. Operation is stabilized by a ceramic capacitor with an output capacitance of 1.0 μF or more in the entire temperature range. However, when using an OS capacitor, tantalum capacitor, or aluminum electrolytic capacitor, a ceramic capacitor with a capacitance of 1.0 μF or more and an ESR of 1.0 Ω or less is required.

The value of the output overshoot or undershoot transient response varies depending on the value of the output capacitor. The required capacitance of the input capacitor differs depending on the application.

The recommended value for an application is 1.0 μF or more for C_{IN} and 1.0 μF or more for C_{L1} equaling C_{L2} ; however, when selecting the output capacitor, perform sufficient evaluation, including evaluation of temperature characteristics, on the actual device.

■ Explanation of Terms

1. Low dropout voltage regulator

The low dropout voltage regulator is a voltage regulator whose dropout voltage is low due to its built-in low on-resistance transistor.

2. Low ESR

A capacitor whose ESR (Equivalent Series Resistance) is low. The S-1711 Series enables use of a low ESR capacitor, such as a ceramic capacitor, for the output-side capacitor C_{L1} , C_{L2} . A capacitor whose ESR is 1.0Ω or less can be used.

3. Output voltage (V_{OUT})

The accuracy of the output voltage is ensured at $\pm 1.0\%$ under the specified conditions of fixed input voltage^{*1}, fixed output current, and fixed temperature.

*1. Differs depending on the product.

Caution If the above conditions change, the output voltage value may vary and exceed the accuracy range of the output voltage. Please see the electrical characteristics and attached characteristics data for details.

4. Line regulation $\left(\frac{\Delta V_{OUT1}}{\Delta V_{IN} \bullet V_{OUT}} \right)$

Indicates the dependency of the output voltage on the input voltage. That is, the values show how much the output voltage changes due to a change in the input voltage with the output current remaining unchanged.

5. Load regulation (ΔV_{OUT2})

Indicates the dependency of the output voltage on the output current. That is, the values show how much the output voltage changes due to a change in the output current with the input voltage remaining unchanged.

6. Dropout voltage (V_{drop})

Indicates the difference between the input voltage V_{IN1} , which is the input voltage (V_{IN}) at the point where the output voltage has fallen to 98% of the output voltage value V_{OUT3} after V_{IN} was gradually decreased from $V_{IN} = V_{OUT(S)} + 1.0 \text{ V}$, and the output voltage at that point ($V_{OUT3} \times 0.98$).

$$V_{drop} = V_{IN1} - (V_{OUT3} \times 0.98)$$

7. Temperature coefficient of output voltage $\left(\frac{\Delta V_{OUT}}{\Delta T_a \bullet V_{OUT}}\right)$

The shadowed area in **Figure 22** is the range where V_{OUT} varies in the operating temperature range when the temperature coefficient of the output voltage is ± 100 ppm/ $^{\circ}\text{C}$.

Ex. $V_{OUT} = 2.8 \text{ V typ.}$

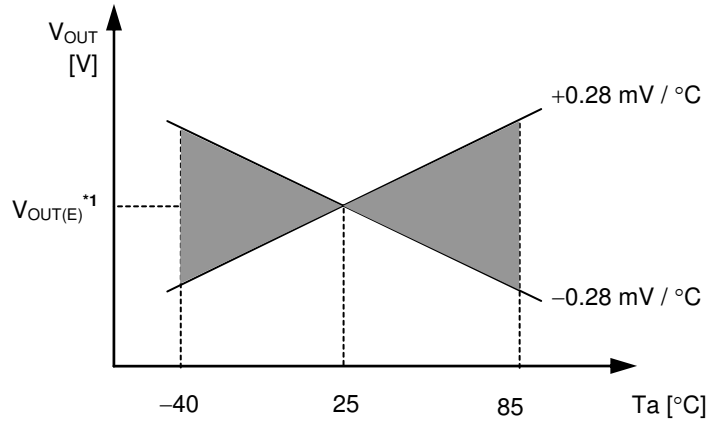

*1. $V_{OUT(E)}$ is the value of the output voltage measured at 25°C .

Figure 22

A change in the temperature of the output voltage [mV/ $^{\circ}\text{C}$] is calculated using the following equation.

$$\frac{\Delta V_{OUT}}{\Delta T_a} [\text{mV}/^{\circ}\text{C}]^{\ast 1} = V_{OUT(S)} [\text{V}]^{\ast 2} \times \frac{\Delta V_{OUT}}{\Delta T_a \bullet V_{OUT}} [\text{ppm}/^{\circ}\text{C}]^{\ast 3} \div 1000$$

- *1. Change in temperature of output voltage
- *2. Specified output voltage
- *3. Output voltage temperature coefficient

■ Operation

1. Basic operation

Figure 23 shows the block diagram of the S-1711 Series.

The error amplifier compares the reference voltage (V_{ref}) with V_{fb} , which is the output voltage resistance-divided by feedback resistors R_s and R_f . It supplies the output transistor with the gate voltage necessary to ensure a certain output voltage free of any fluctuations of input voltage and temperature.

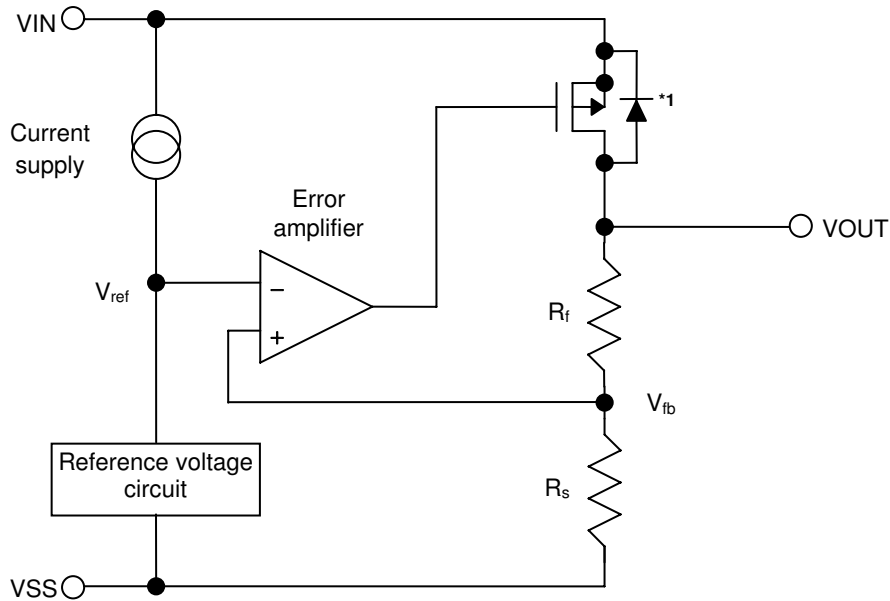

*1. Parasitic diode

Figure 23

2. Output transistor

The S-1711 Series uses a low on-resistance P-channel MOS FET as the output transistor.

Be sure that V_{OUT} does not exceed $V_{IN} + 0.3$ V to prevent the voltage regulator from being damaged due to inverse current flowing from the V_{OUT} pin through a parasitic diode to the V_{IN} pin.

3. ON/OFF pins 1 and 2

These pins start and stop the regulator.

When the ON/OFF pin is set to the shutdown level, the entire internal circuit stops operating, and the built-in P-channel MOS FET output transistor between the VIN and VOUT pins is turned off, reducing current consumption significantly.

Since the S-1711 Series A/ B/ E/ F types have a built-in discharge shunt circuit to discharge the output capacitance, the VOUT pin is forcibly set to V_{SS} level. In the S-1711 Series C/ D/ G/ and H types, the VOUT pin is set to V_{SS} level through several hundred kΩ internal divided resistors between the VOUT and VSS pins. Note that the current consumption increases when a voltage of 0.3 V to VIN – 0.3 V is applied to the ON/OFF pin.

The ON/OFF pin is configured as shown in **Figures 24** and **25**. In the S-1711 Series A/ C/ E/ G types, the ON/OFF pin is internally pulled up or pulled down to VSS when in the floating status, so the VOUT pin is set to the V_{SS} level. In the S-1711 Series B/ D/ F/ H types, the ON/OFF pin is not internally pulled up or pulled down, so do not use these types with the ON/OFF pin in the floating status. When the ON/OFF pin is not used in the S-1711 Series B/ D/ F/ H types, connect the pin to the VIN pin in the B/ D types, and connect it to the VSS pin in the F/ H types.

Table 14

Logic Type	ON/OFF Pin	Internal Circuits	VOUT Pin Voltage	Current Consumption
A/ B/ C/ D	“H”: Power on	Operating	Set value	I _{SS1} ^{*1}
A/ B/ C/ D	“L”: Shutdown	Stopped	V _{SS} level	I _{SS2}
E/ F/ G/ H	“H”: Shutdown	Stopped	V _{SS} level	I _{SS2}
E/ F/ G/ H	“L”: Power on	Operating	Set value	I _{SS1} ^{*1}

*1. Note with caution that the power consumption of the IC is higher by that to be input to pull-up resistance or pull-down resistance the power off pin when the S-1711 Series A/ C types operated with the ON/OFF pin connected to VIN and the S-1711 Series E/ G types with the ON/OFF pin connected to VSS (refer to **Figure 24**).

(1) S-1711 Series A/ C/ E/ G Type

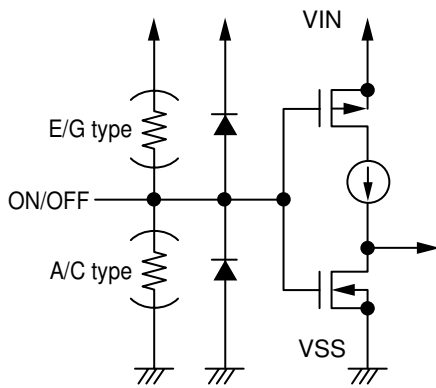

Figure 24

(2) S-1711 Series B/ D/ F/ H Type

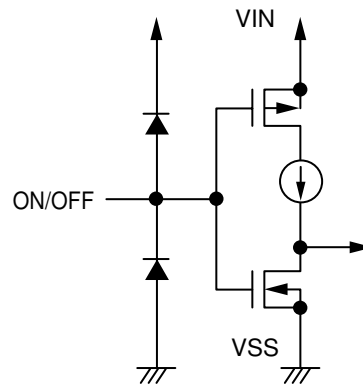

Figure 25

4. Discharge shunt function (S-1711 Series A/ B/ E/ F types)

The S-1711 Series A/ B/ E/ F types have built-in discharge shunt circuits to discharge the output capacitance. When the ON/OFF pin is set to shutdown level, turns the output transistor off, and turns the discharge shunt function on so that the output capacitor discharges. These types allow for the VOUT pin reach V_{SS} level rapidly when compared with the S-1711 Series C/ D/ G/ H types that does not have discharge shunt circuits.

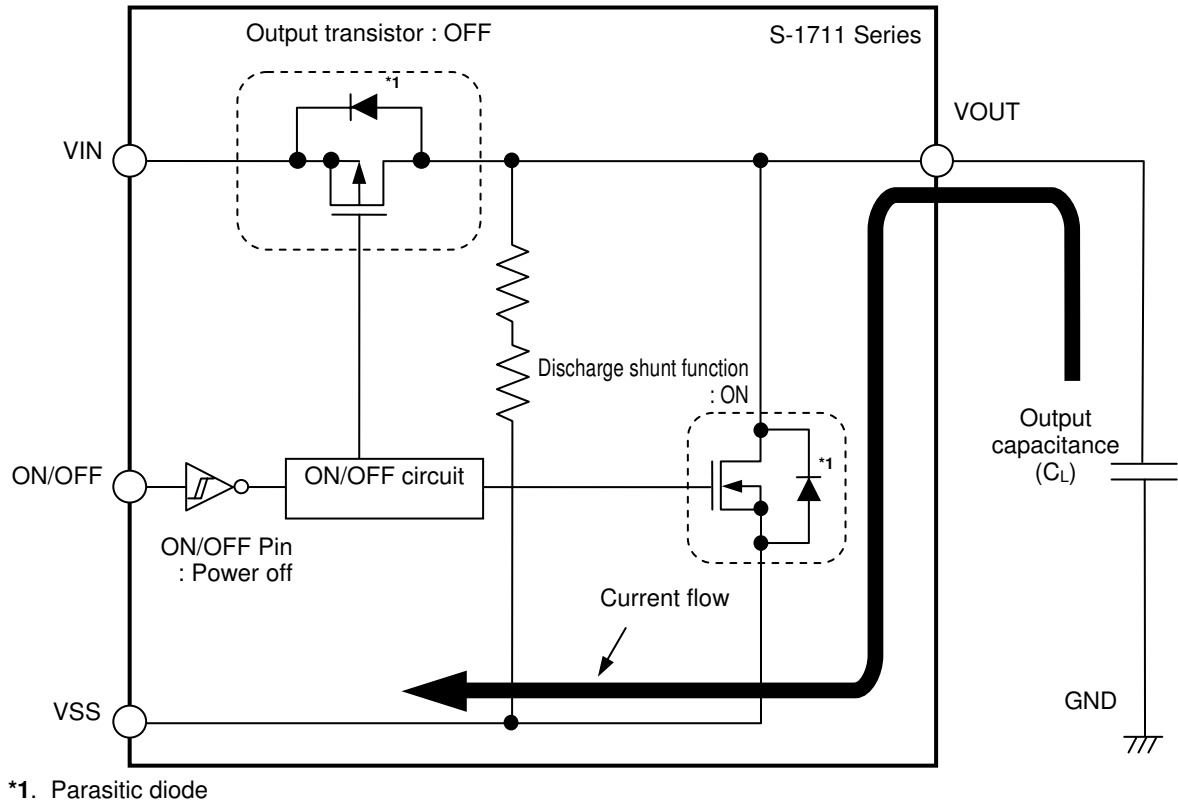

Figure 26

5. Pull-down/pull-up resistor (S-1711 Series A/ C/ E/ G types)

In the S-1711 Series A/ C/ E/ G types, the ON/OFF pin is internally pulled up to VIN or pulled down to VSS, so the VOUT pin is in the VSS level when in the floating status.

Note with caution that the power consumption of the IC is higher by that to be input to pull-up resistance or pull-down resistance the power off pin when the S-1711 Series A/ C types operated with the ON/OFF pin connected to VIN and the S-1711 Series E/ G types with the ON/OFF pin connected to VSS.

■ Precautions

- Wiring patterns for the VIN, VOUT and GND pins should be designed so that the impedance is low. When mounting an output capacitor between the VOUT and VSS pins (C_{L1} , C_{L2}) and a capacitor for stabilizing the input between VIN and VSS pins (C_{IN}), the distance from the capacitors to these pins should be as short as possible.
- Note that the output voltage may increase when a series regulator is used at low load current (1.0 mA or less).
- Note that the output voltage may increase due to driver leakage when a series regulator is used at high temperatures.
- Generally a series regulator may cause oscillation, depending on the selection of external parts. The following conditions are recommended for this IC. However, be sure to perform sufficient evaluation under the actual usage conditions for selection, including evaluation of temperature characteristics.

Input capacitor (C_{IN}):	1.0 μ F or more
Output capacitor (C_{L1} , C_{L2}):	1.0 μ F or more
Equivalent series resistance (ESR):	1.0 Ω or less

Use input/output capacitor which has good temperature characteristics (conforming to the ceramic capacitor EIA X5R (JIS B) characteristics).

- The voltage regulator may oscillate when the impedance of the power supply is high and the input capacitor is small or an input capacitor is not connected.
- If the capacitance of the IC's output block is small, the power supply fluctuation and load fluctuation characteristics become worse. It is therefore important to sufficiently evaluate the output voltage fluctuation in the actual equipment.
- When the capacitance of the IC's output block is small, if the power supply suddenly increases sharply, a momentary overshoot may be output. It is therefore important to sufficiently evaluate the output voltage at power application in the actual equipment.
- The application conditions for the input voltage, output voltage, and load current should not exceed the package power dissipation.
- Do not apply an electrostatic discharge to this IC that exceeds the performance ratings of the built-in electrostatic protection circuit.
- In determining the output current, attention should be paid to the output current value specified in **Table 13** in the electrical characteristics and footnote *5) of the table.
- SII claims no responsibility for any disputes arising out of or in connection with any infringement by products including this IC of patents owned by a third party.

■ Characteristics (Typical Data) (Per circuit)

(1) Output Voltage vs. Output Current (When Load Current Increases) (Ta = 25°C)

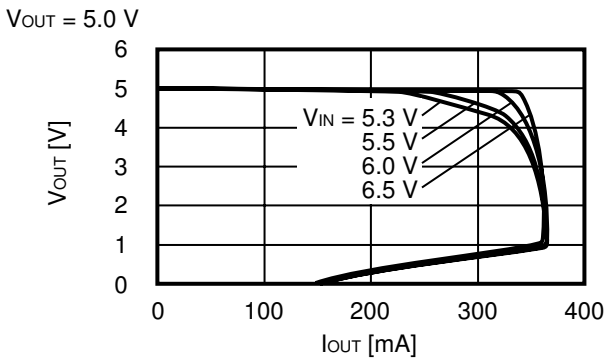
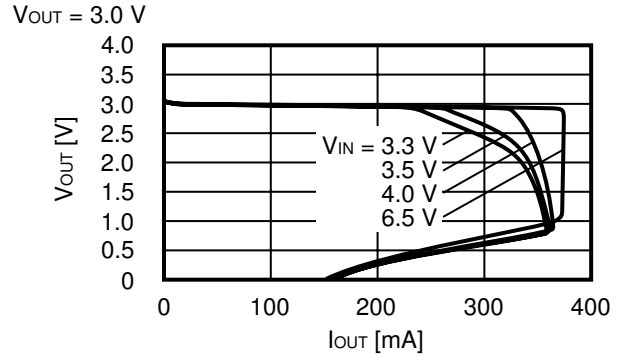
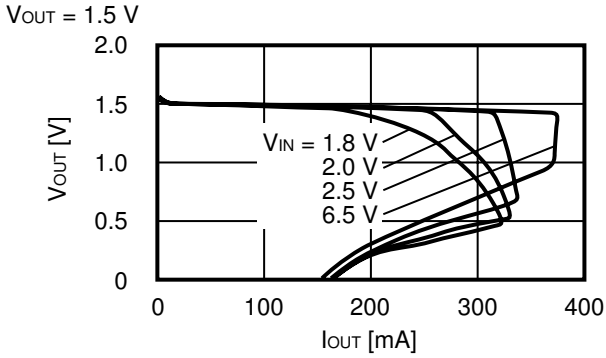

Remark In determining the output current, attention should be paid to the following.

1. The minimum output current value and footnote *5 specified in **Table 13** in the “**Electrical Characteristics**”
2. The package power dissipation

(2) Output Voltage vs. Input Voltage (Ta = 25°C)

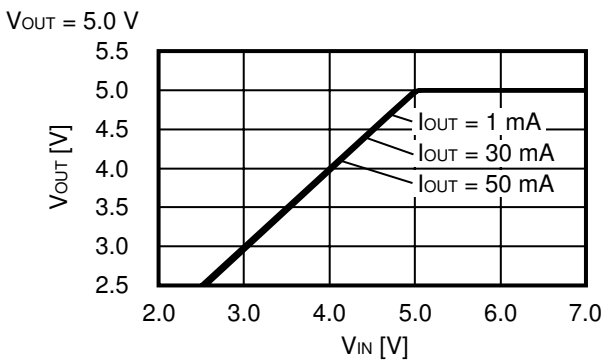
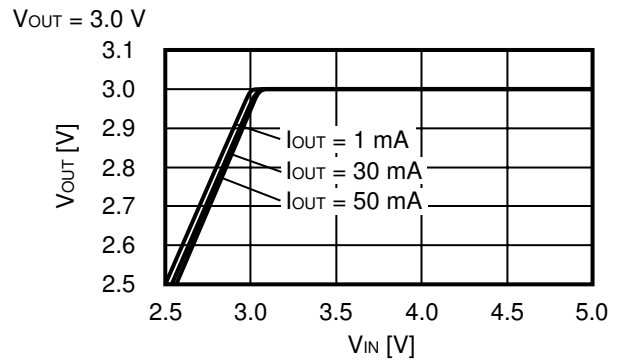
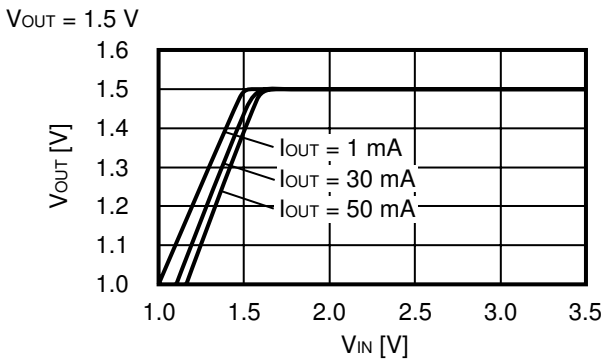

(3) Dropout Voltage vs. Output Current

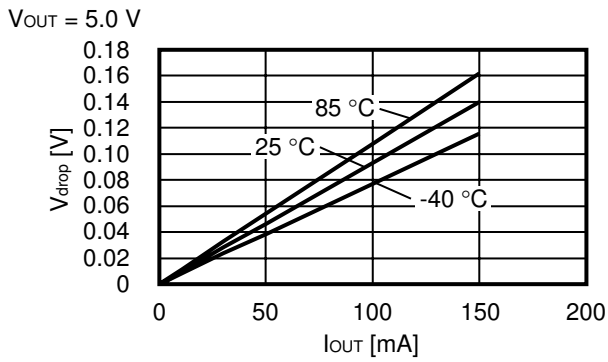
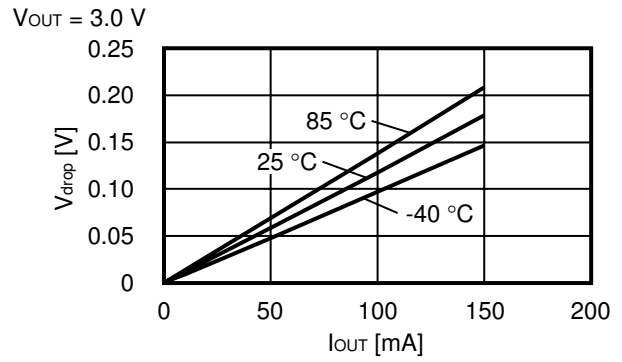
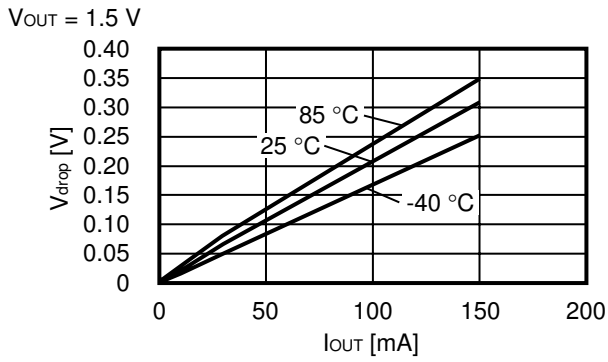

(4) Dropout Voltage vs. Set Output Voltage

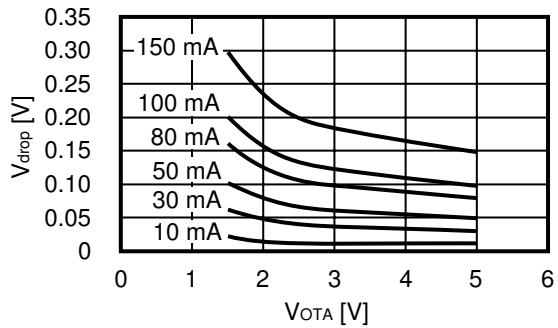

(5) Output Voltage vs. Ambient Temperature

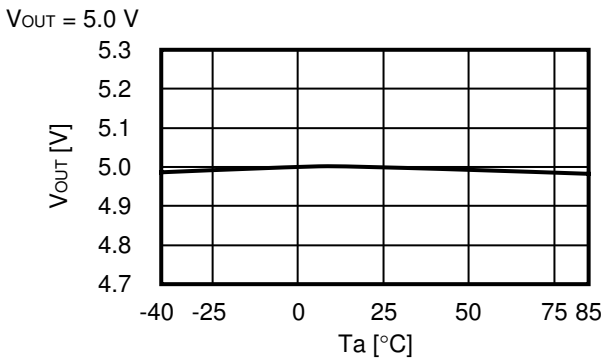
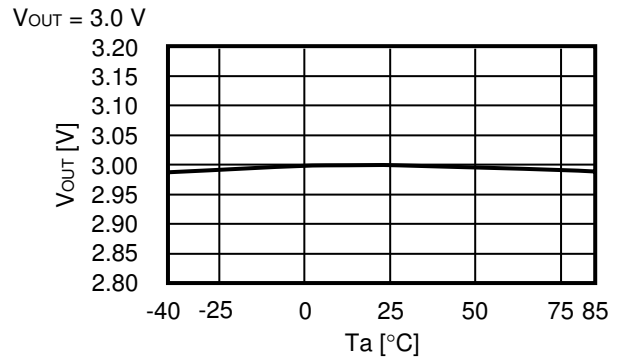
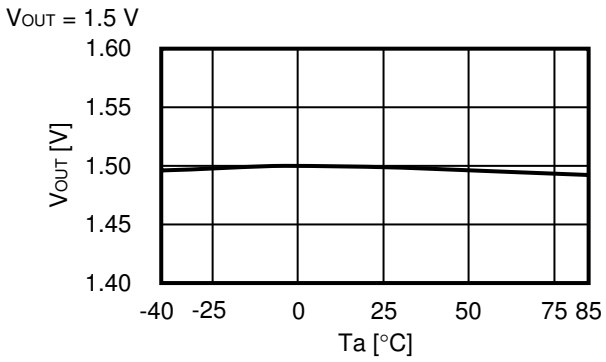

(6) Current Consumption vs. Input Voltage

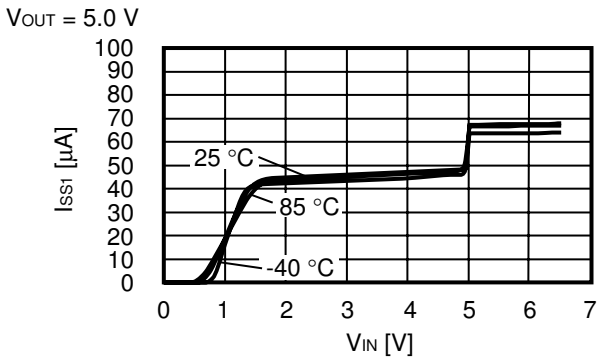
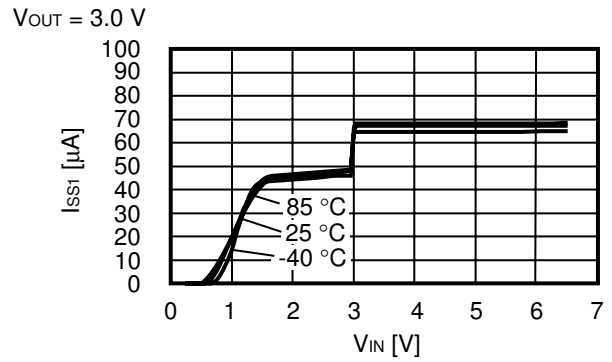
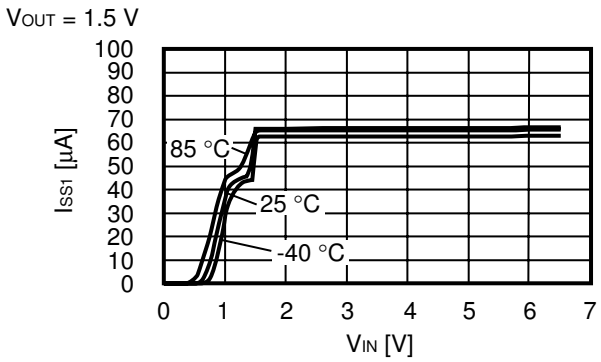

(7) Ripple Rejection ($T_a = 25^\circ\text{C}$)

$V_{OUT} = 1.5\text{ V}$

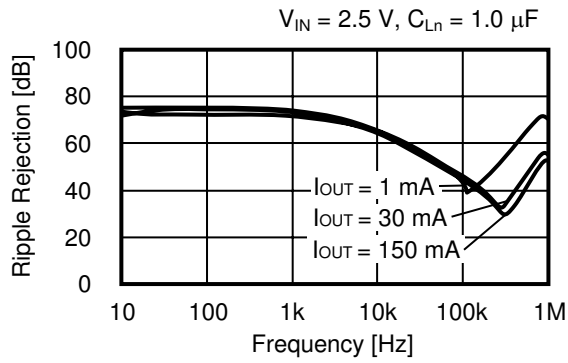

$V_{OUT} = 3.0\text{ V}$

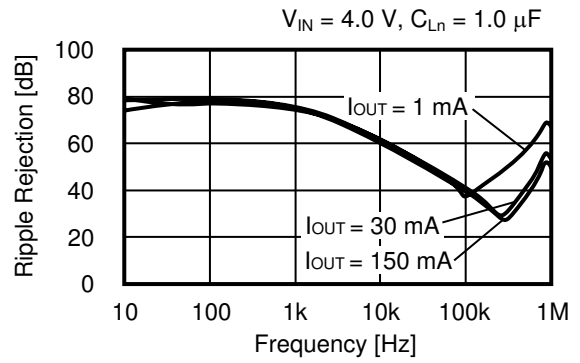

$V_{OUT} = 5.0\text{ V}$

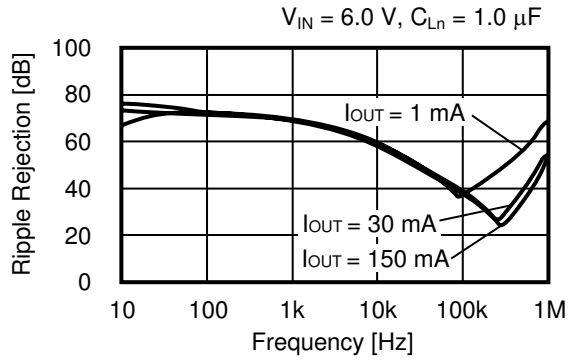

Remark C_{L_n} : Capacitor set to V_{OUTn} pin externally ($n = 1, 2$)

■ Reference Data (Per circuit)

(1) Input Transient Response Characteristics (Ta = 25°C) Common to VR1 and 2

V_{OUT} = 1.5 V

I_{OUT} = 30 mA, tr = tf = 5.0 μs, C_{Ln} = 1.0 μF, C_{IN} = 1.0 μF

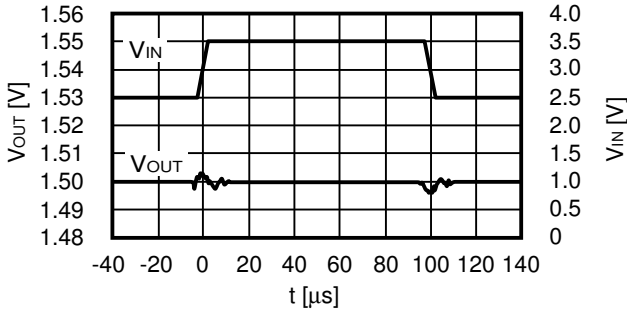

V_{OUT} = 3.0 V

I_{OUT} = 30 mA, tr = tf = 5.0 μs, C_{Ln} = 1.0 μF, C_{IN} = 1.0 μF

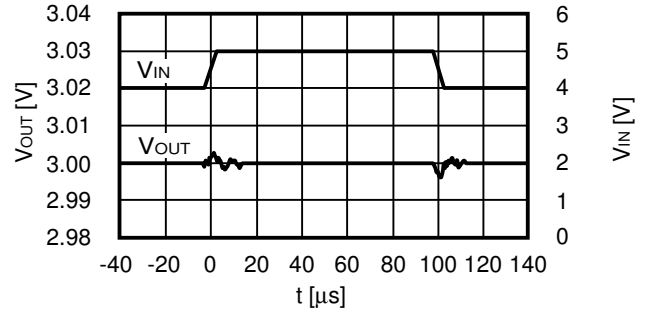

V_{OUT} = 5.0 V

I_{OUT} = 30 mA, tr = tf = 5.0 μs, C_{Ln} = 1.0 μF, C_{IN} = 1.0 μF

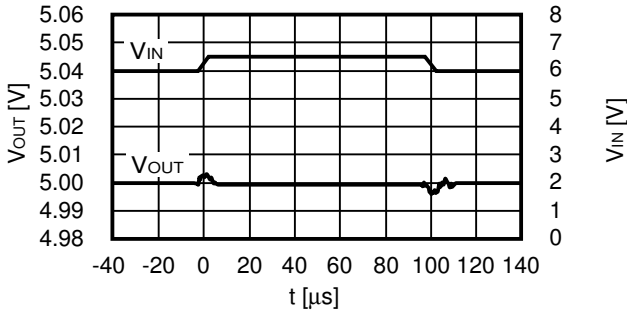

(2) Load Transient Response Characteristics (Ta = 25°C)

V_{OUT} = 1.5 V

V_{IN} = 2.5 V, C_{Ln} = 1.0 μF, C_{IN} = 1.0 μF, I_{OUT} = 50 ↔ 100 mA

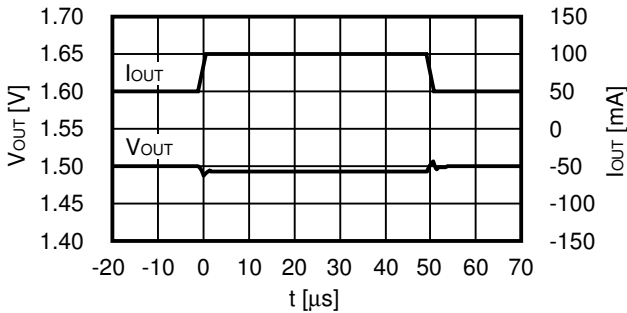

V_{OUT} = 3.0 V

V_{IN} = 4.0 V, C_{Ln} = 1.0 μF, C_{IN} = 1.0 μF, I_{OUT} = 50 ↔ 100 mA

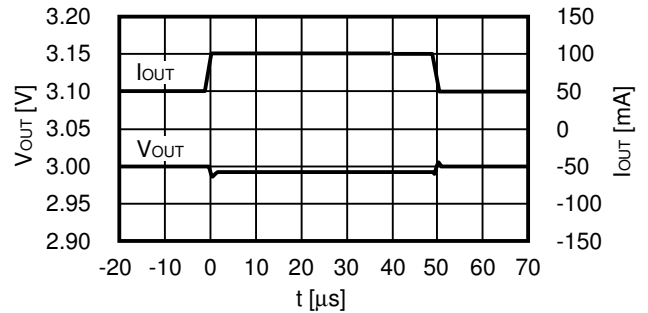

V_{OUT} = 5.0 V

V_{IN} = 6.0 V, C_{Ln} = 1.0 μF, C_{IN} = 1.0 μF, I_{OUT} = 50 ↔ 100 mA

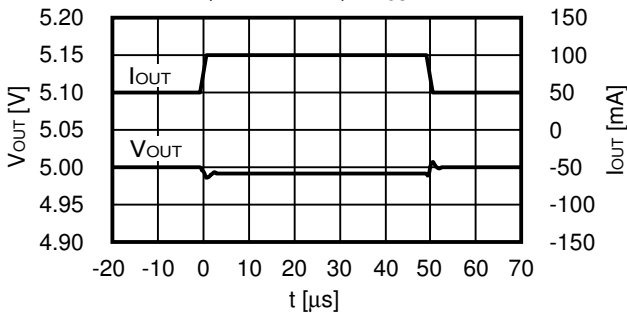

Remark C_{Ln}: Capacitor set to VOUTn pin externally (n = 1, 2)

(3) ON / OFF Pin Transient Response Characteristics (Ta = 25°C)

V_{OUT} = 1.5 V

V_{IN} = 2.5 V, C_{Ln} = 1.0 μF, C_{IN} = 1.0 μF, I_{OUT} = 100 mA

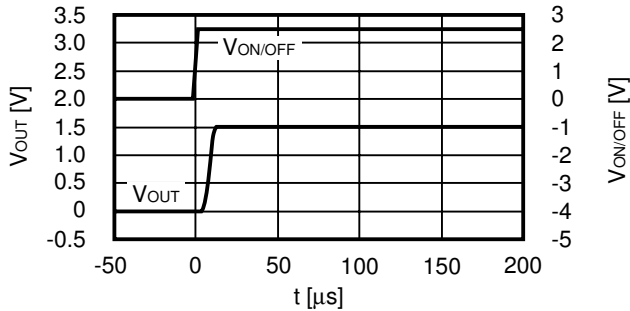

V_{OUT} = 3.0 V

V_{IN} = 4.0 V, C_{Ln} = 1.0 μF, C_{IN} = 1.0 μF, I_{OUT} = 100 mA

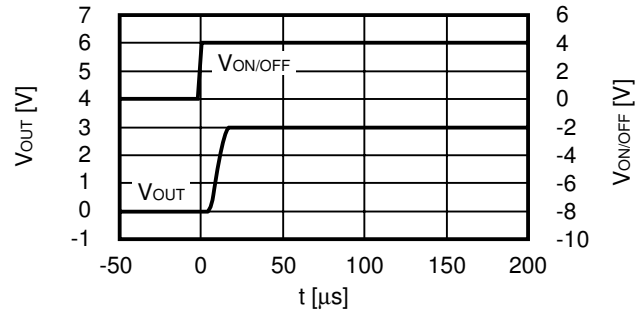

V_{OUT} = 5.0 V

V_{IN} = 6.0 V, C_{Ln} = 1.0 μF, C_{IN} = 1.0 μF, I_{OUT} = 100 mA

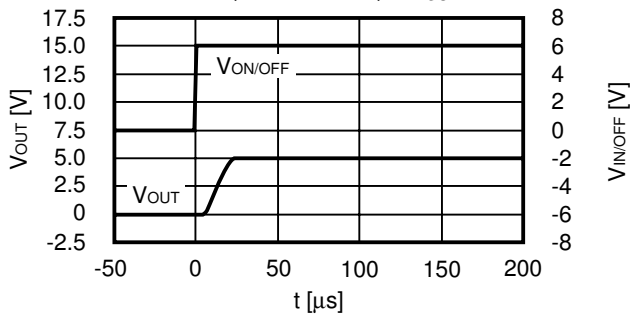

(4) Output Capacitance vs. Discharge Time Characteristics (Ta = 25°C)
S-1711 Series A / B type (with discharge shunt function)

V_{IN} = V_{OUT} + 1.0 V, I_{OUT} = no load,

V_{ON/OFF} = V_{OUT} + 1.0 V → V_{SS}, t_f = 1 μs

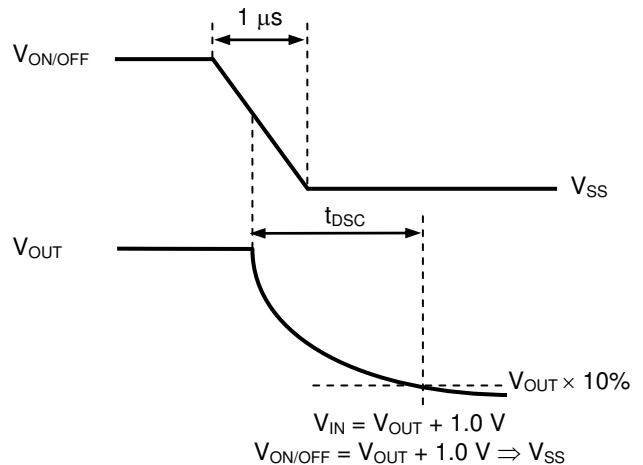
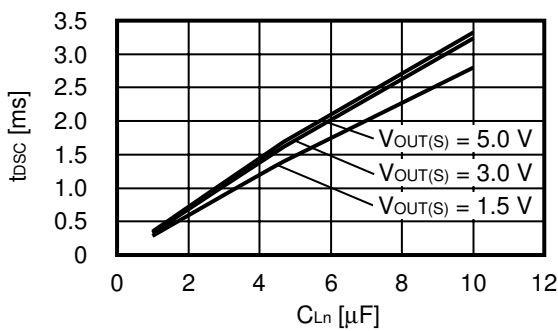
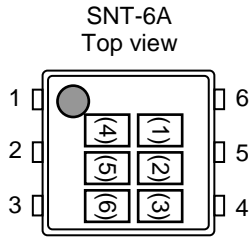

Figure 27 Measurement Condition of Discharge Time

Remark C_{Ln}: Capacitor set to VOUTn pin externally (n = 1, 2)

■ Marking Specifications

(1) SNT-6A



(1) to (3) : Product code (Refer to **Product name vs. Product code**)
 (4) to (6) : Lot number

Product name vs. Product code

(a) S-1711 Series A type

Product Name	Product code		
	(1)	(2)	(3)
S-1711A1515-I6T1x	Q	R	A
S-1711A1518-I6T1x	Q	Q	D
S-1711A1526-I6T1x	Q	V	T
S-1711A1528-I6T1x	Q	V	I
S-1711A152J-I6T1x	Q	Q	I
S-1711A1533-I6T1x	Q	V	W
S-1711A1815-I6T1x	Q	R	Y
S-1711A1818-I6T1x	Q	V	F
S-1711A1827-I6T1x	Q	R	P
S-1711A182H-I6T1x	Q	R	Q
S-1711A1828-I6T1x	Q	R	5
S-1711A182J-I6T1x	Q	V	S
S-1711A1829-I6T1x	Q	V	L
S-1711A1830-I6T1x	Q	V	H
S-1711A1833-I6T1x	Q	R	7
S-1711A1J28-I6T1x	Q	R	Z
S-1711A2332-I6T1x	Q	V	U
S-1711A2333-I6T1x	Q	V	V
S-1711A2424-I6T1x	Q	R	R
S-1711A2425-I6T1x	Q	R	S
S-1711A2515-I6T1x	Q	R	L
S-1711A2518-I6T1x	Q	R	E
S-1711A2525-I6T1x	Q	R	T
S-1711A2528-I6T1x	Q	V	D
S-1711A2533-I6T1x	Q	V	E
S-1711A2626-I6T1x	Q	V	M
S-1711A2628-I6T1x	Q	V	7
S-1711A2629-I6T1x	Q	V	8

Product Name	Product code		
	(1)	(2)	(3)
S-1711A2630-I6T1x	Q	V	9
S-1711A2815-I6T1x	Q	R	U
S-1711A2818-I6T1x	Q	R	V
S-1711A2828-I6T1x	Q	R	B
S-1711A2829-I6T1x	Q	R	2
S-1711A2830-I6T1x	Q	R	D
S-1711A2831-I6T1x	Q	Q	A
S-1711A2832-I6T1x	Q	R	F
S-1711A2833-I6T1x	Q	R	G
S-1711A2J15-I6T1x	Q	Q	F
S-1711A2J18-I6T1x	Q	Q	G
S-1711A2J2J-I6T1x	Q	R	H
S-1711A2J33-I6T1x	Q	Q	C
S-1711A2929-I6T1x	Q	R	J
S-1711A3015-I6T1x	Q	R	X
S-1711A3018-I6T1x	Q	R	W
S-1711A3025-I6T1x	Q	R	M
S-1711A3028-I6T1x	Q	V	Z
S-1711A3030-I6T1x	Q	R	K
S-1711A3033-I6T1x	Q	R	N
S-1711A3128-I6T1x	Q	Q	B
S-1711A3318-I6T1x	Q	V	R
S-1711A3333-I6T1x	Q	R	3
S-1711A3348-I6T1x	Q	V	J
S-1711A3350-I6T1x	Q	V	2
S-1711A3434-I6T1x	Q	V	6
S-1711A5025-I6T1x	Q	V	3
S-1711A5030-I6T1x	Q	R	8

- Remark 1.** Please contact the SII marketing department for products with specifications other than the above.
2. x: G or U
3. Please select products of environmental code = U for Sn 100%, halogen-free products.

(b) S-1711 Series B type

Product Name	Product code		
	(1)	(2)	(3)
S-1711B1518-I6T1x	Q	U	H
S-1711B1528-I6T1x	Q	Z	C
S-1711B1825-I6T1x	Q	U	K
S-1711B1828-I6T1x	Q	U	B
S-1711B1833-I6T1x	Q	U	J
S-1711B2518-I6T1x	Q	U	A
S-1711B2528-I6T1x	Q	U	C
S-1711B2815-I6T1x	Q	U	D
S-1711B2818-I6T1x	Q	U	E
S-1711B2828-I6T1x	Q	U	F
S-1711B2833-I6T1x	Q	Z	D
S-1711B3033-I6T1x	Q	Z	A
S-1711B3333-I6T1x	Q	Z	B

(d) S-1711 Series D type

Product Name	Product code		
	(1)	(2)	(3)
S-1711D1828-I6T1x	Q	U	N
S-1711D1925-I6T1x	Q	U	R
S-1711D2518-I6T1x	Q	U	O
S-1711D2528-I6T1x	Q	U	P
S-1711D252J-I6T1x	Q	U	Y
S-1711D2815-I6T1x	Q	U	Q
S-1711D2J2J-I6T1x	Q	U	U

(c) S-1711 Series C type

Product Name	Product code		
	(1)	(2)	(3)
S-1711C1515-I6T1x	Q	S	A
S-1711C1815-I6T1x	Q	S	B
S-1711C1827-I6T1x	Q	S	C
S-1711C182H-I6T1x	Q	S	D
S-1711C1828-I6T1x	Q	S	Z
S-1711C1J28-I6T1x	Q	S	E
S-1711C2424-I6T1x	Q	S	F
S-1711C2425-I6T1x	Q	S	G
S-1711C2515-I6T1x	Q	S	H
S-1711C2518-I6T1x	Q	S	I
S-1711C2525-I6T1x	Q	S	J
S-1711C2815-I6T1x	Q	S	K
S-1711C2818-I6T1x	Q	S	L
S-1711C2828-I6T1x	Q	S	M
S-1711C2829-I6T1x	Q	S	N
S-1711C2830-I6T1x	Q	S	O
S-1711C2833-I6T1x	Q	S	P
S-1711C2J2J-I6T1x	Q	S	Q
S-1711C2929-I6T1x	Q	S	R
S-1711C3015-I6T1x	Q	S	S
S-1711C3018-I6T1x	Q	S	T
S-1711C3025-I6T1x	Q	S	U
S-1711C3030-I6T1x	Q	S	V
S-1711C3033-I6T1x	Q	S	W

(e) S-1711 Series E type

Product Name	Product code		
	(1)	(2)	(3)
S-1711E2818-I6T1x	Q	T	A

(f) S-1711 Series F type

Product Name	Product code		
	(1)	(2)	(3)
S-1711F2818-I6T1x	Q	T	F

(g) S-1711 Series G type

Product Name	Product code		
	(1)	(2)	(3)
S-1711G2830-I6T1x	Q	T	K

- Remark 1.** Please contact the SII marketing department for products with specifications other than the above.
2. x: G or U
3. Please select products of environmental code = U for Sn 100%, halogen-free products.

(2) SOT-23-6

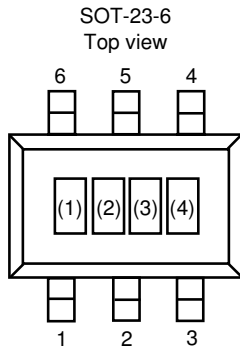

(1) to (3): Product code (Refer to **Product name vs. Product code**)
 (4): Lot number

Product name vs. Product code

(a) S-1711 Series A type

Product Name	Product code		
	(1)	(2)	(3)
S-1711A1515-M6T1x	Q	R	A
S-1711A1528-M6T1x	Q	V	I
S-1711A1529-M6T1x	Q	V	K
S-1711A1533-M6T1x	Q	V	W
S-1711A1815-M6T1x	Q	R	Y
S-1711A1818-M6T1x	Q	V	F
S-1711A1825-M6T1x	Q	R	4
S-1711A1827-M6T1x	Q	R	P
S-1711A182H-M6T1x	Q	R	Q
S-1711A1828-M6T1x	Q	R	5
S-1711A182J-M6T1x	Q	V	S
S-1711A1829-M6T1x	Q	V	L
S-1711A1830-M6T1x	Q	V	H
S-1711A1832-M6T1x	Q	V	N
S-1711A1833-M6T1x	Q	R	7
S-1711A1J28-M6T1x	Q	R	Z
S-1711A2045-M6T1x	Q	V	G
S-1711A2424-M6T1x	Q	R	R
S-1711A2425-M6T1x	Q	R	S
S-1711A2515-M6T1x	Q	R	L
S-1711A2518-M6T1x	Q	R	E
S-1711A2522-M6T1x	Q	V	O
S-1711A2525-M6T1x	Q	R	T
S-1711A2528-M6T1x	Q	V	D
S-1711A2529-M6T1x	Q	R	9
S-1711A2533-M6T1x	Q	V	E
S-1711A2618-M6T1x	Q	V	4

Product Name	Product code		
	(1)	(2)	(3)
S-1711A2718-M6T1x	Q	V	5
S-1711A2815-M6T1x	Q	R	U
S-1711A2818-M6T1x	Q	R	V
S-1711A2819-M6T1x	Q	V	P
S-1711A2825-M6T1x	Q	V	C
S-1711A2828-M6T1x	Q	R	B
S-1711A2829-M6T1x	Q	R	2
S-1711A2830-M6T1x	Q	R	D
S-1711A2832-M6T1x	Q	R	F
S-1711A2833-M6T1x	Q	R	G
S-1711A2J2J-M6T1x	Q	R	H
S-1711A2J30-M6T1x	Q	V	X
S-1711A2929-M6T1x	Q	R	J
S-1711A2933-M6T1x	Q	V	Y
S-1711A3015-M6T1x	Q	R	X
S-1711A3018-M6T1x	Q	R	W
S-1711A3025-M6T1x	Q	R	M
S-1711A3030-M6T1x	Q	R	K
S-1711A3033-M6T1x	Q	R	N
S-1711A3325-M6T1x	Q	V	A
S-1711A3328-M6T1x	Q	V	B
S-1711A3330-M6T1x	Q	R	6
S-1711A3333-M6T1x	Q	R	3
S-1711A3348-M6T1x	Q	V	J
S-1711A4020-M6T1x	Q	V	Q
S-1711A5025-M6T1x	Q	V	3

- Remark 1.** Please contact the SII marketing department for products with specifications other than the above.
2. x: G or U
3. Please select products of environmental code = U for Sn 100%, halogen-free products.

(b) S-1711 Series B type

Product Name	Product code		
	(1)	(2)	(3)
S-1711B1518-M6T1x	Q	U	H
S-1711B1529-M6T1x	Q	U	I
S-1711B1825-M6T1x	Q	U	K
S-1711B1828-M6T1x	Q	U	B
S-1711B1832-M6T1x	Q	U	M
S-1711B1833-M6T1x	Q	U	J
S-1711B2515-M6T1x	Q	U	G
S-1711B2518-M6T1x	Q	U	A
S-1711B2528-M6T1x	Q	U	C
S-1711B2618-M6T1x	Q	Z	G
S-1711B2718-M6T1x	Q	Z	H
S-1711B2815-M6T1x	Q	U	D
S-1711B2818-M6T1x	Q	U	E
S-1711B2825-M6T1x	Q	U	L
S-1711B2828-M6T1x	Q	U	F
S-1711B3030-M6T1x	Q	Z	I
S-1711B3033-M6T1x	Q	Z	A
S-1711B3036-M6T1x	Q	Z	F
S-1711B3333-M6T1x	Q	Z	B

(d) S-1711 Series D type

Product Name	Product code		
	(1)	(2)	(3)
S-1711D1825-M6T1x	Q	U	S
S-1711D1826-M6T1x	Q	U	W
S-1711D1828-M6T1x	Q	U	N
S-1711D1832-M6T1x	Q	U	T
S-1711D1925-M6T1x	Q	U	R
S-1711D2518-M6T1x	Q	U	O
S-1711D2528-M6T1x	Q	U	P
S-1711D2629-M6T1x	Q	U	X
S-1711D2815-M6T1x	Q	U	Q
S-1711D4230-M6T1x	Q	U	V

(c) S-1711 Series C type

Product Name	Product code		
	(1)	(2)	(3)
S-1711C1515-M6T1x	Q	S	A
S-1711C1815-M6T1x	Q	S	B
S-1711C1825-M6T1x	Q	S	2
S-1711C1827-M6T1x	Q	S	C
S-1711C182H-M6T1x	Q	S	D
S-1711C1832-M6T1x	Q	S	X
S-1711C1J28-M6T1x	Q	S	E
S-1711C2424-M6T1x	Q	S	F
S-1711C2425-M6T1x	Q	S	G
S-1711C2515-M6T1x	Q	S	H
S-1711C2518-M6T1x	Q	S	I
S-1711C2525-M6T1x	Q	S	J
S-1711C2815-M6T1x	Q	S	K
S-1711C2818-M6T1x	Q	S	L
S-1711C2828-M6T1x	Q	S	M
S-1711C2829-M6T1x	Q	S	N
S-1711C2830-M6T1x	Q	S	O
S-1711C2833-M6T1x	Q	S	P
S-1711C2J2J-M6T1x	Q	S	Q
S-1711C2929-M6T1x	Q	S	R
S-1711C3015-M6T1x	Q	S	S
S-1711C3018-M6T1x	Q	S	T
S-1711C3025-M6T1x	Q	S	U
S-1711C3030-M6T1x	Q	S	V
S-1711C3033-M6T1x	Q	S	W
S-1711C3131-M6T1x	Q	S	Y

(e) S-1711 Series E type

Product Name	Product code		
	(1)	(2)	(3)
S-1711E1833-M6T1x	Q	T	C
S-1711E2818-M6T1x	Q	T	A
S-1711E3333-M6T1x	Q	T	B

(f) S-1711 Series H type

Product Name	Product code		
	(1)	(2)	(3)
S-1711H2518-M6T1x	Q	T	P

- Remark 1.** Please contact the SII marketing department for products with specifications other than the above.
2. x: G or U
3. Please select products of environmental code = U for Sn 100%, halogen-free products.

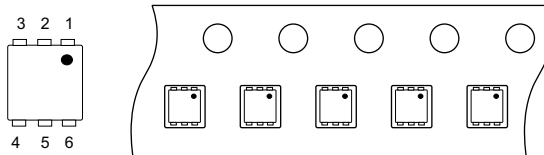
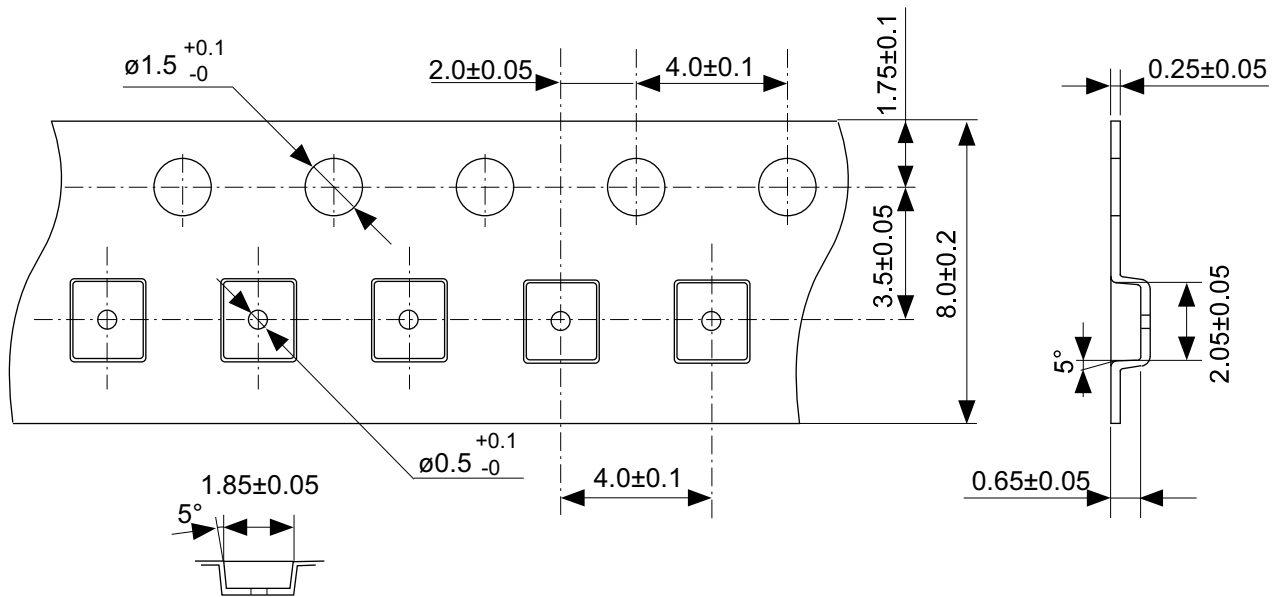

Feed direction →

No. PG006-A-C-SD-1.0

TITLE	SNT-6A-A-Carrier Tape
No.	PG006-A-C-SD-1.0
SCALE	
UNIT	mm
Seiko Instruments Inc.	

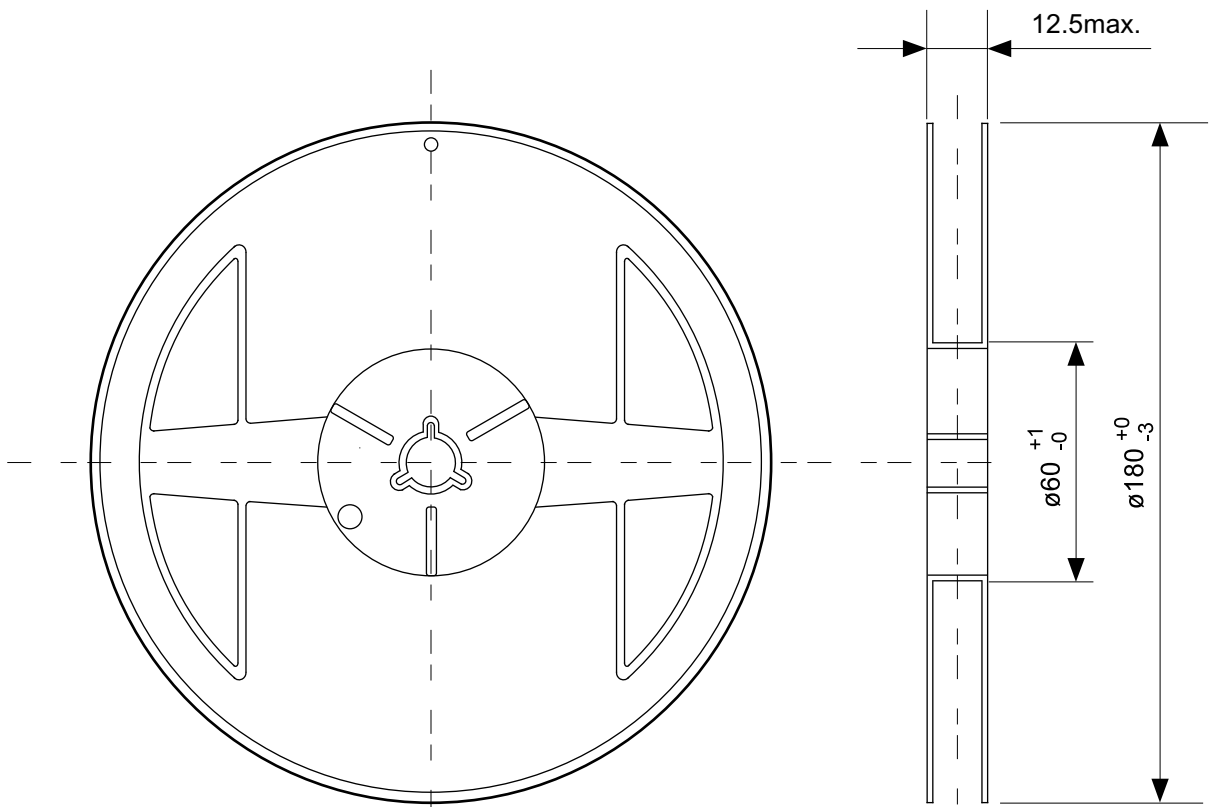

Enlarged drawing in the central part

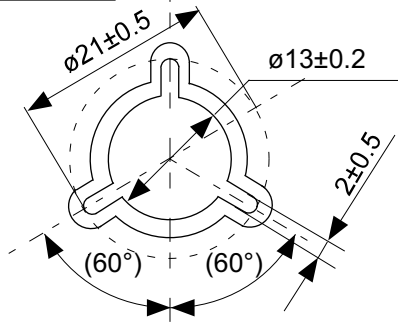

No. PG006-A-R-SD-1.0

TITLE	SNT-6A-A-Reel		
No.	PG006-A-R-SD-1.0		
SCALE		QTY.	5,000
UNIT	mm		
Seiko Instruments Inc.			

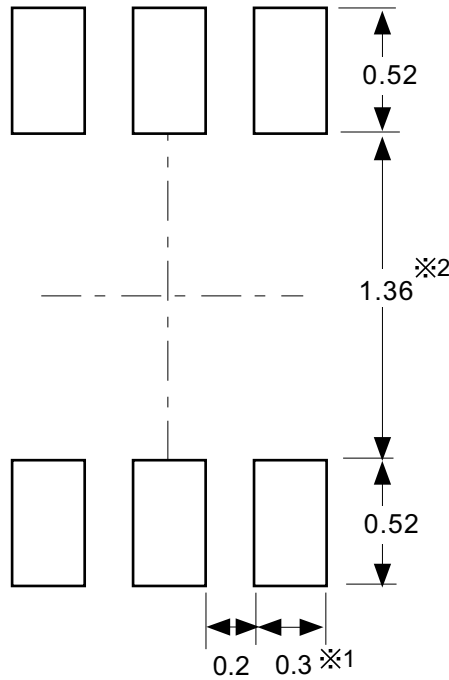

※1. ランドパターンの幅に注意してください (0.25 mm min. / 0.30 mm typ.).
 ※2. パッケージ中央にランドパターンを広げないでください (1.30 mm ~ 1.40 mm)。

- 注意
1. パッケージのモールド樹脂下にシルク印刷やハンダ印刷などしないでください。
 2. パッケージ下の配線上のソルダーレジストなどの厚みをランドパターン表面から0.03 mm以下にしてください。
 3. マスク開口サイズと開口位置はランドパターンと合わせてください。
 4. 詳細は“SNTパッケージ活用の手引き”を参照してください。

※1. Pay attention to the land pattern width (0.25 mm min. / 0.30 mm typ.).
 ※2. Do not widen the land pattern to the center of the package (1.30 mm ~ 1.40 mm).

- Caution**
1. Do not do silkscreen printing and solder printing under the mold resin of the package.
 2. The thickness of the solder resist on the wire pattern under the package should be 0.03 mm or less from the land pattern surface.
 3. Match the mask aperture size and aperture position with the land pattern.
 4. Refer to "SNT Package User's Guide" for details.

※1. 请注意焊盘模式的宽度 (0.25 mm min. / 0.30 mm typ.).
 ※2. 请勿向封装中间扩展焊盘模式 (1.30 mm ~ 1.40 mm)。

- 注意
1. 请勿在树脂型封装的下面印刷丝网、焊锡。
 2. 在封装下、布线上的阻焊膜厚度 (从焊盘模式表面起) 请控制在0.03 mm以下。
 3. 掩膜的开口尺寸和开口位置请与焊盘模式对齐。
 4. 详细内容请参阅 "SNT封装的应用指南"。

No. PG006-A-L-SD-4.0

TITLE	SNT-6A-A-Land Recommendation
No.	PG006-A-L-SD-4.0
SCALE	
UNIT	mm
Seiko Instruments Inc.	

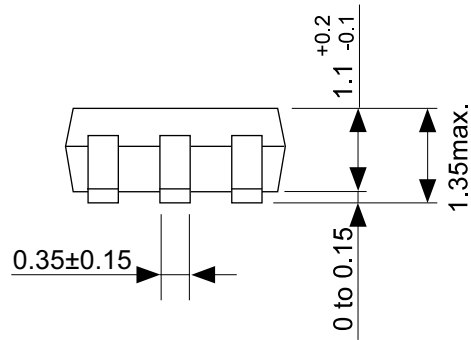
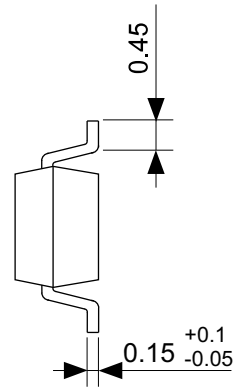
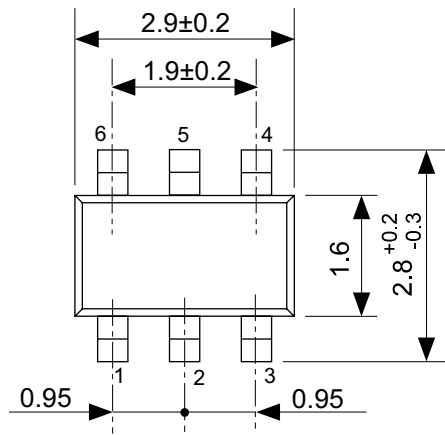

No. MP006-A-P-SD-2.0

TITLE	SOT236-A-PKG Dimensions
No.	MP006-A-P-SD-2.0
SCALE	
UNIT	mm
Seiko Instruments Inc.	

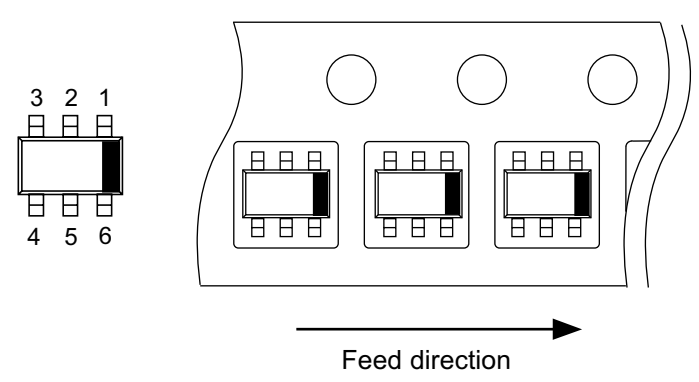
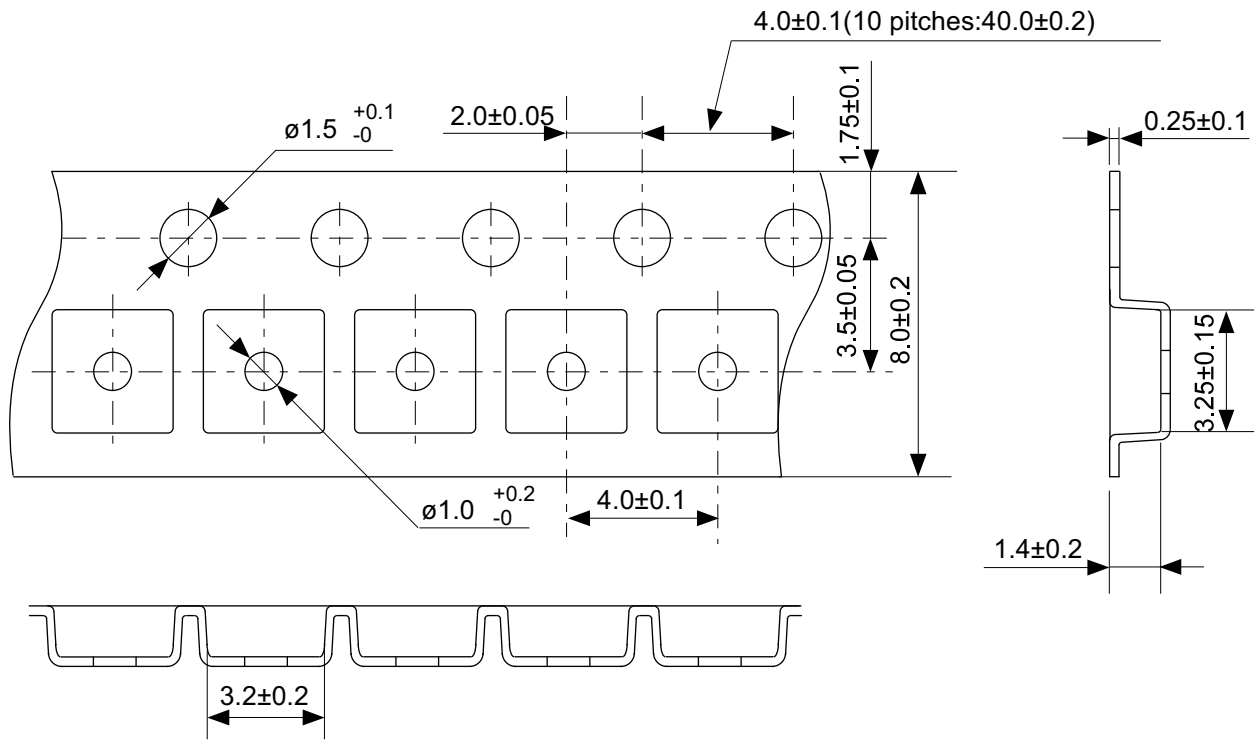

No. MP006-A-C-SD-3.1

TITLE	SOT236-A-Carrier Tape
No.	MP006-A-C-SD-3.1
SCALE	
UNIT	mm
Seiko Instruments Inc.	

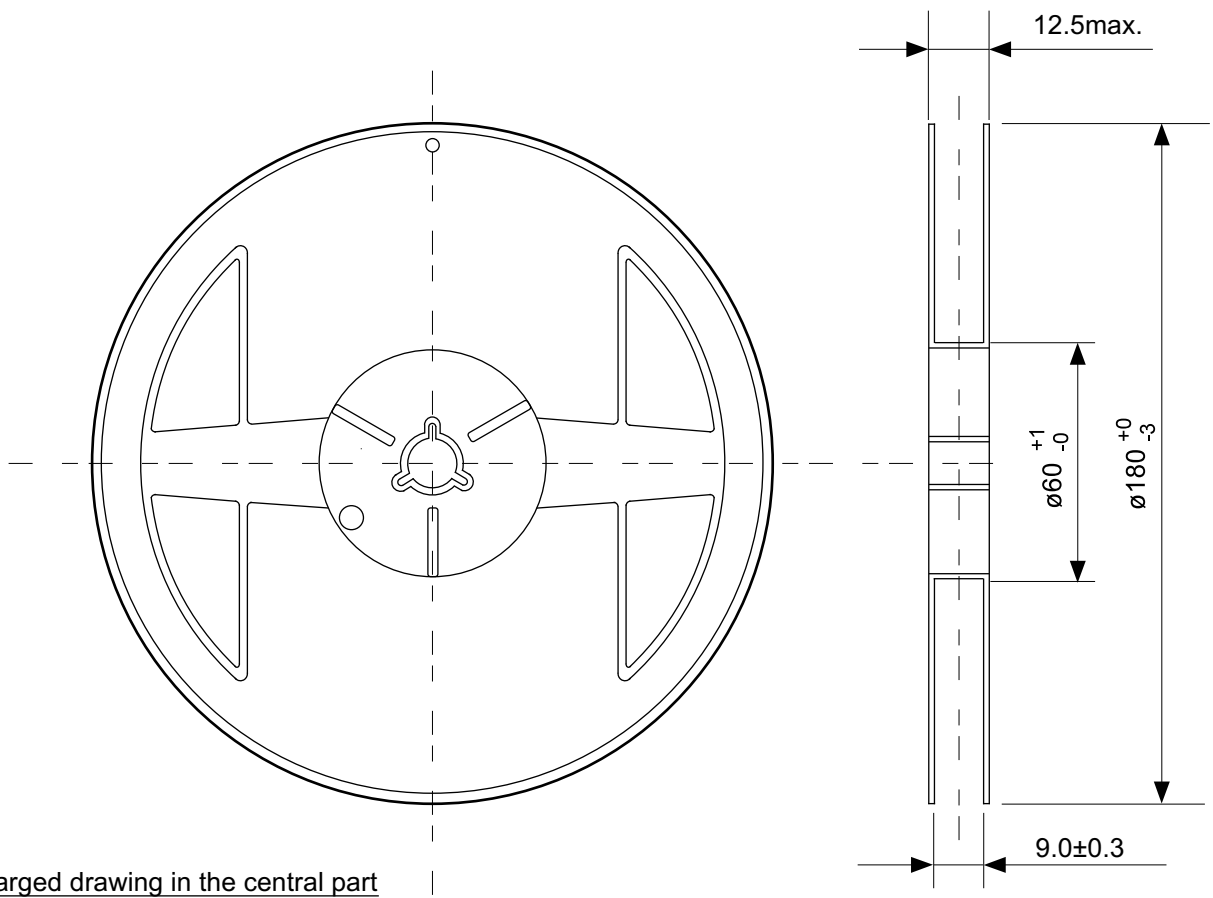

Enlarged drawing in the central part

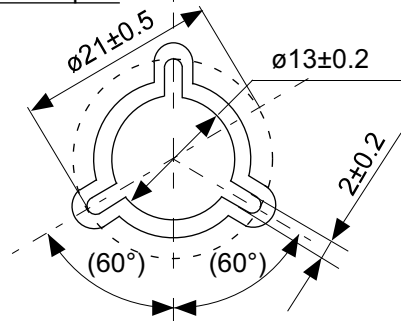

No. MP006-A-R-SD-2.1

TITLE	SOT236-A-Reel		
No.	MP006-A-R-SD-2.1		
SCALE		QTY	3,000
UNIT	mm		
Seiko Instruments Inc.			



Seiko Instruments Inc.
www.sii-ic.com

- The information described herein is subject to change without notice.
- Seiko Instruments Inc. is not responsible for any problems caused by circuits or diagrams described herein whose related industrial properties, patents, or other rights belong to third parties. The application circuit examples explain typical applications of the products, and do not guarantee the success of any specific mass-production design.
- When the products described herein are regulated products subject to the Wassenaar Arrangement or other agreements, they may not be exported without authorization from the appropriate governmental authority.
- Use of the information described herein for other purposes and/or reproduction or copying without the express permission of Seiko Instruments Inc. is strictly prohibited.
- The products described herein cannot be used as part of any device or equipment affecting the human body, such as exercise equipment, medical equipment, security systems, gas equipment, vehicle equipment, in-vehicle equipment, aviation equipment, aerospace equipment, and nuclear-related equipment, without prior written permission of Seiko Instruments Inc.
- The products described herein are not designed to be radiation-proof.
- Although Seiko Instruments Inc. exerts the greatest possible effort to ensure high quality and reliability, the failure or malfunction of semiconductor products may occur. The user of these products should therefore give thorough consideration to safety design, including redundancy, fire-prevention measures, and malfunction prevention, to prevent any accidents, fires, or community damage that may ensue.