

SUPER-SMALL PACKAGE 2-CIRCUIT HIGH RIPPLE-REJECTION LOW CURRENT CONSUMPTION LOW DROPOUT CMOS VOLTAGE REGULATOR

www.sii-ic.com

© Seiko Instruments Inc., 2007-2010

Rev.2.0_00

S-1721 Series, developed using the CMOS technology, is a 2-channel positive voltage regulator IC which has the low dropout voltage, the high-accuracy output voltage and the low output current consumption of 150 mA.

Users are able to use a small ceramic capacitor of 1.0 μF for this IC. This IC includes two regulator circuits in the package SOT-23-6 or super-small SNT-6A.

S-1721 Series has much lower current consumption than S-1711 Series, this IC is ideal for mobile devices.

■ Features

- Output voltage: 1.2 V to 5.0 V, selectable in 0.05 V step.
- A ceramic capacitor of 1.0 μF or more can be used as the I/O capacitor.
- Wide input voltage range: 1.7 V to 6.5 V
- High-accuracy output voltage: $\pm 1.0\%$
- Low dropout voltage: 130 mV typ. (products having the output of 3.0 V, $I_{\text{OUT}} = 100 \text{ mA}$)
- Low current consumption:
 - During operation: 25 μA typ., 45 μA max. (products having the output of 3.0 V, per circuit)
 - During shutdown: 0.1 μA typ., 1.0 μA max.
- Output current: Possible to output 150 mA (at $V_{\text{IN}} \geq V_{\text{OUT(S)}} + 1.0 \text{ V}$)*¹ (per circuit)
- High ripple rejection: 80 dB typ. (products having the output under 1.8 V, at 1.0 kHz)
- Built-in overcurrent protector: limits overcurrent of output transistor
- Built-in ON/OFF circuit: Ensures long battery life.
- Pull-up or pull-down resistor can be selected.
- Lead-free, Sn 100%, halogen-free*²

*1. Attention should be paid to the power dissipation of the package when the output current is large.

*2. Refer to “■ Product Name Structure” for details.

■ Applications

- Power supply for cellular phones
- Power supply for battery-powered devices

■ Packages

- SNT-6A
- SOT-23-6

■ **Block Diagrams**

1. **S-1721 Series A type**

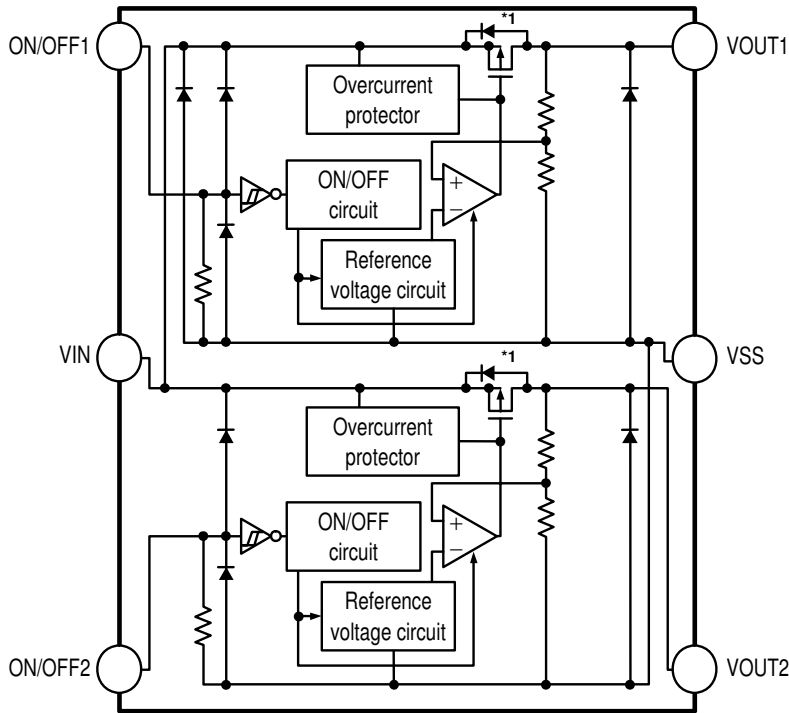

| Function | Status | |
|--------------------|--------|------------|
| ON/OFF logic | 1ch | Active "H" |
| | 2ch | Active "H" |
| Pull-up resistor | 1ch | None |
| | 2ch | None |
| Pull-down resistor | 1ch | Available |
| | 2ch | Available |

*1. Parasitic diode

Figure 1

2. **S-1721 Series B type**

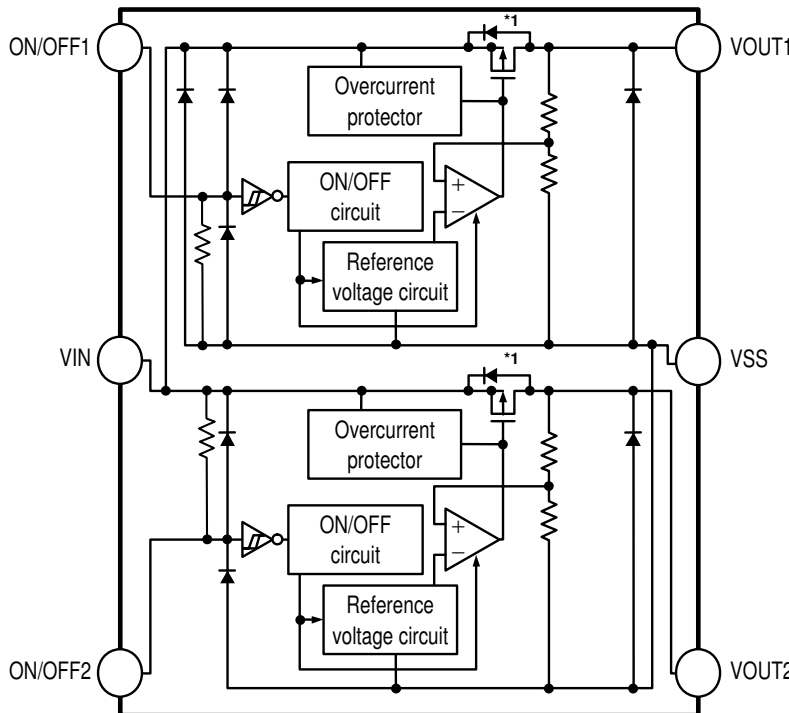

| Function | Status | |
|--------------------|--------|------------|
| ON/OFF logic | 1ch | Active "H" |
| | 2ch | Active "L" |
| Pull-up resistor | 1ch | None |
| | 2ch | Available |
| Pull-down resistor | 1ch | Available |
| | 2ch | None |

*1. Parasitic diode

Figure 2

3. S-1721 Series C type

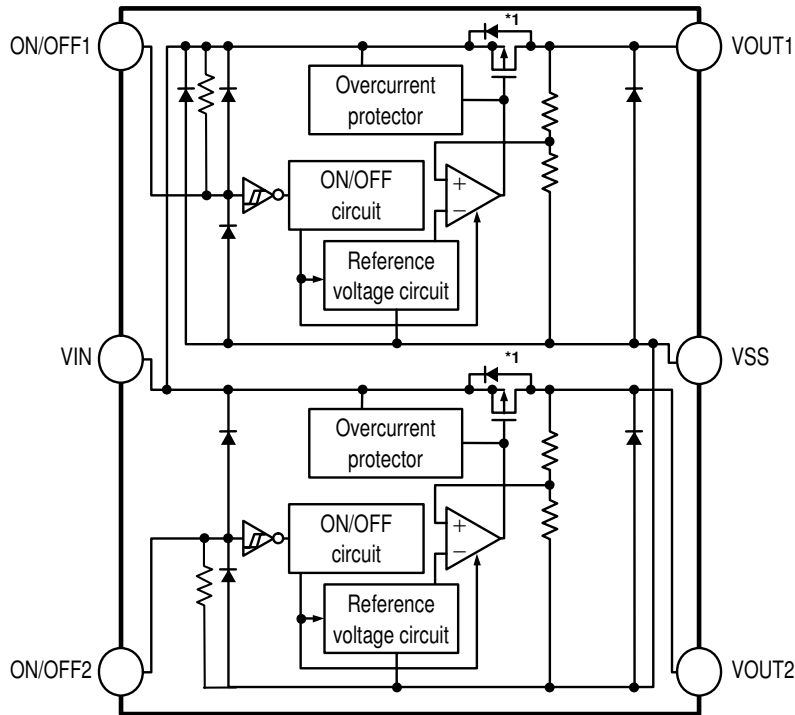

| Function | | Status |
|--------------------|-----|------------|
| ON/OFF logic | 1ch | Active "L" |
| | 2ch | Active "H" |
| Pull-up resistor | 1ch | Available |
| | 2ch | None |
| Pull-down resistor | 1ch | None |
| | 2ch | Available |

*1. Parasitic diode

Figure 3

4. S-1721 Series D type

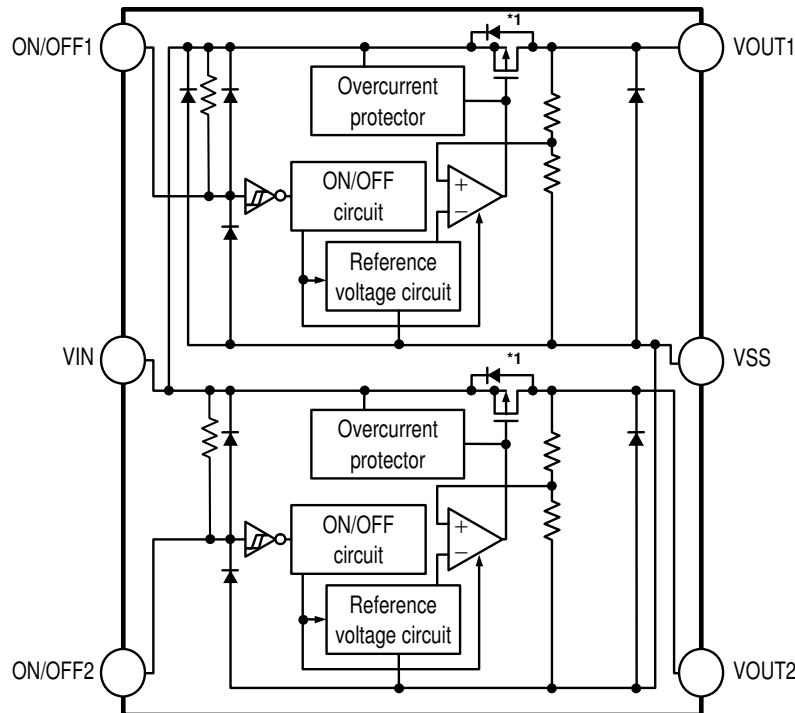

| Function | | Status |
|--------------------|-----|------------|
| ON/OFF logic | 1ch | Active "L" |
| | 2ch | Active "L" |
| Pull-up resistor | 1ch | Available |
| | 2ch | Available |
| Pull-down resistor | 1ch | None |
| | 2ch | None |

*1. Parasitic diode

Figure 4

5. S-1721 Series E type

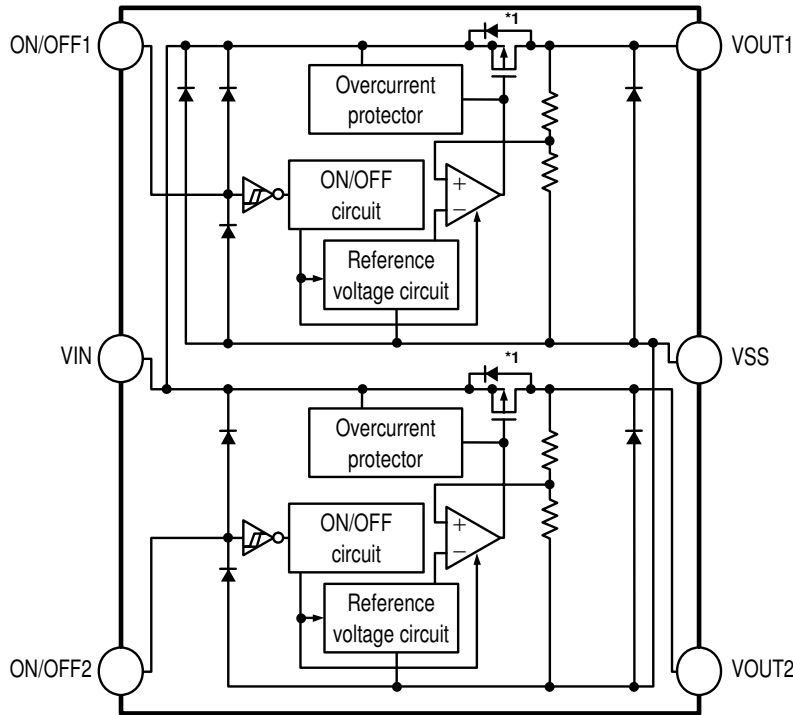

| Function | | Status |
|--------------------|-----|------------|
| ON/OFF logic | 1ch | Active "H" |
| | 2ch | Active "H" |
| Pull-up resistor | 1ch | None |
| | 2ch | None |
| Pull-down resistor | 1ch | None |
| | 2ch | None |

*1. Parasitic diode

Figure 5

6. S-1721 Series F type

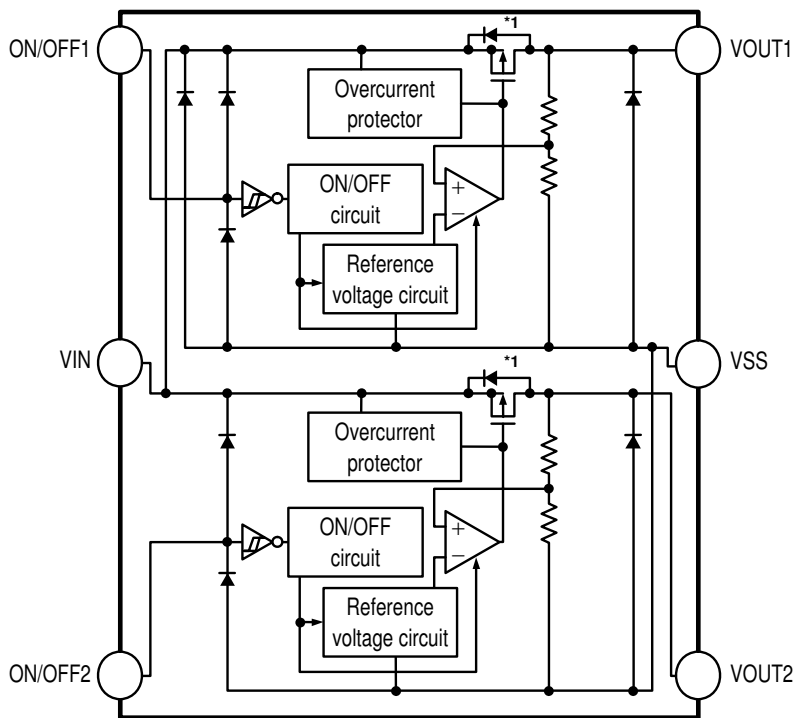

| Function | | Status |
|--------------------|-----|------------|
| ON/OFF logic | 1ch | Active "H" |
| | 2ch | Active "L" |
| Pull-up resistor | 1ch | None |
| | 2ch | None |
| Pull-down resistor | 1ch | None |
| | 2ch | None |

*1. Parasitic diode

Figure 6

7. S-1721 Series G type

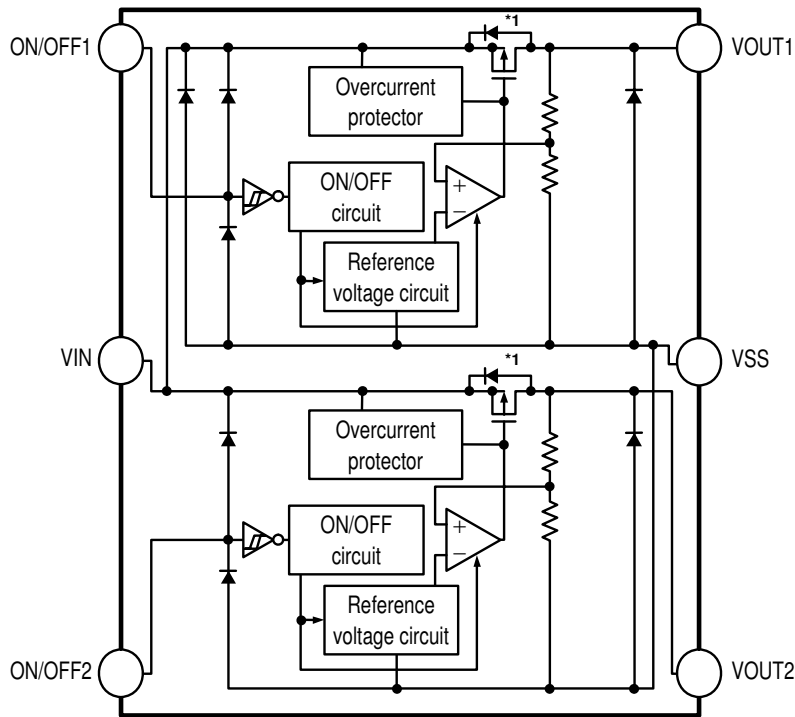

| Function | Status | |
|--------------------|--------|------------|
| ON/OFF logic | 1ch | Active "L" |
| | 2ch | Active "H" |
| Pull-up resistor | 1ch | None |
| | 2ch | None |
| Pull-down resistor | 1ch | None |
| | 2ch | None |

*1. Parasitic diode

Figure 7

8. S-1721 Series H type

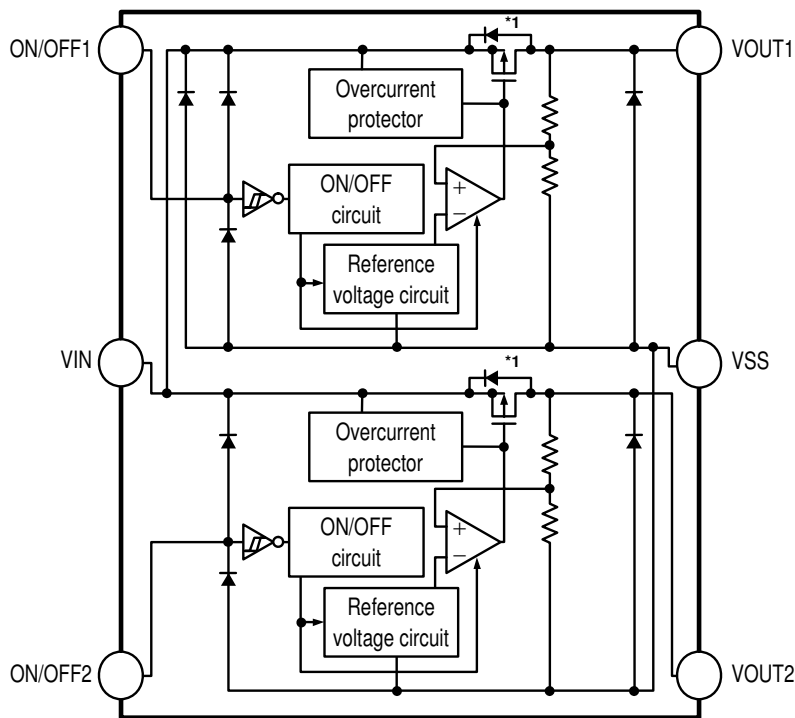

| Function | Status | |
|--------------------|--------|------------|
| ON/OFF logic | 1ch | Active "L" |
| | 2ch | Active "L" |
| Pull-up resistor | 1ch | None |
| | 2ch | None |
| Pull-down resistor | 1ch | None |
| | 2ch | None |

*1. Parasitic diode

Figure 8

■ **Product Name Structure**

Users can select the product type, output voltage, and package type for the S-1721 Series. Refer to “**1. Product name**” regarding the contents of product name, “**2. Function list of product type**” regarding the product type, “**3. Package**” regarding the package drawings and “**4. Product name list**” regarding details of product name.

1. Product name

1.1 SNT-6A

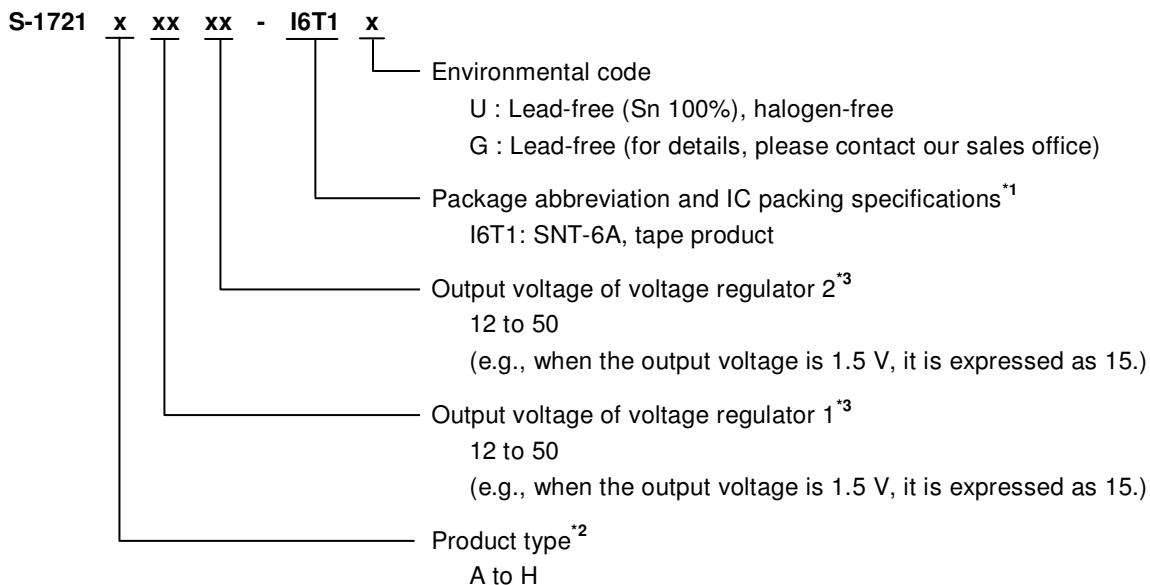

- *1. Refer to the tape specifications.
- *2. Refer to “**2. Function list of product type**”.
- *3. If you request the product which has 0.05 V step, contact our sales office.

1.2 SOT-23-6

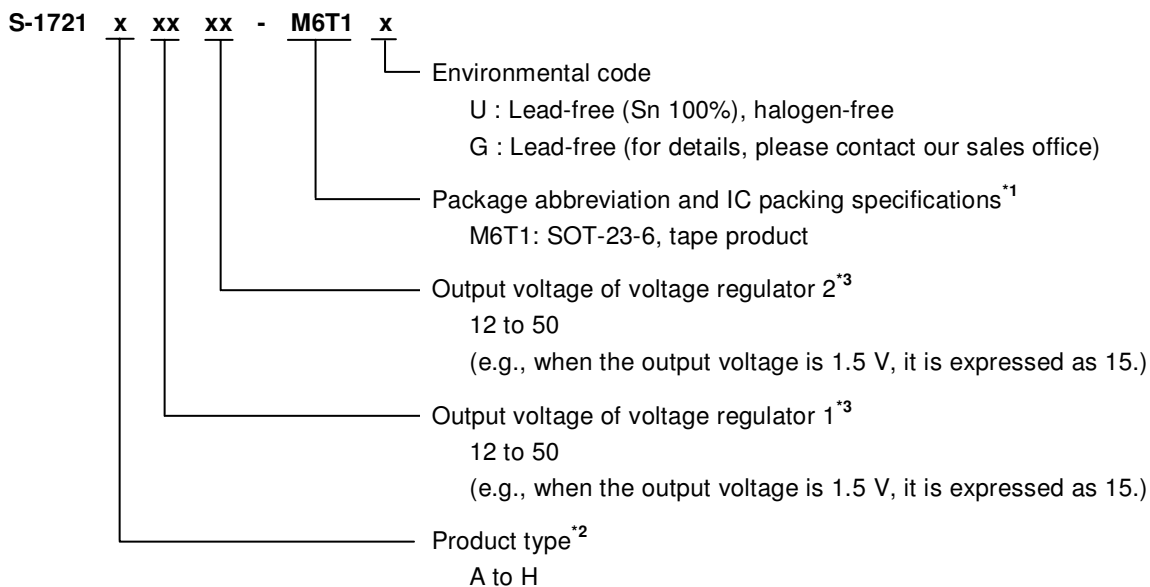

- *1. Refer to the tape specifications.
- *2. Refer to “**2. Function list of product type**”.
- *3. If you request the product which has 0.05 V step, contact our sales office.

2. Function list of product type

Table 1

| Product Type | ON/OFF Logic | Pull-up Resistor | Pull-down Resistor |
|--------------|----------------------------------|--------------------------------|--------------------------------|
| A type | 1ch Active "H" 2ch Active "H" | 1ch None 2ch None | 1ch Available 2ch Available |
| B type | 1ch Active "H" 2ch Active "L" | 1ch None 2ch Available | 1ch Available 2ch None |
| C type | 1ch Active "L" 2ch Active "H" | 1ch Available 2ch None | 1ch None 2ch Available |
| D type | 1ch Active "L" 2ch Active "L" | 1ch Available 2ch Available | 1ch None 2ch None |
| E type | 1ch Active "H" 2ch Active "H" | 1ch None 2ch None | 1ch None 2ch None |
| F type | 1ch Active "H" 2ch Active "L" | 1ch None 2ch None | 1ch None 2ch None |
| G type | 1ch Active "L" 2ch Active "H" | 1ch None 2ch None | 1ch None 2ch None |
| H type | 1ch Active "L" 2ch Active "L" | 1ch None 2ch None | 1ch None 2ch None |

3. Package

| Package Name | Drawing Code | | | |
|--------------|--------------|--------------|--------------|--------------|
| | Package | Tape | Reel | Land |
| SNT-6A | PG006-A-P-SD | PG006-A-C-SD | PG006-A-R-SD | PG006-A-L-SD |
| SOT-23-6 | MP006-A-P-SD | MP006-A-C-SD | MP006-A-R-SD | — |

4. Product name list

4.1 S-1721 series A type

ON/OFF logic : 1ch : Active "H", 2ch : Active "H"
 Pull-up resistor : 1ch : None, 2ch : None
 Pull-down resistor : 1ch : Available, 2ch : Available

Table 2 (1 / 2)

| Voltage Regulator 1 Output Voltage | Voltage Regulator 2 Output Voltage | SNT-6A | SOT-23-6 |
|---------------------------------------|---------------------------------------|-------------------|-------------------|
| 1.2 V ±15 mV | 1.2 V ±15 mV | S-1721A1212-I6T1x | S-1721A1212-M6T1x |
| 1.2 V ±15 mV | 1.5 V ±1.0% | S-1721A1215-I6T1x | S-1721A1215-M6T1x |
| 1.2 V ±15 mV | 1.8 V ±1.0% | S-1721A1218-I6T1x | - |
| 1.2 V ±15mV | 2.5 V ±1.0% | S-1721A1225-I6T1x | - |
| 1.2 V ±15 mV | 2.6 V ±1.0% | S-1721A1226-I6T1x | - |
| 1.2 V ±15 mV | 2.8 V ±1.0% | S-1721A1228-I6T1x | S-1721A1228-M6T1x |
| 1.2 V ±15 mV | 2.85 V ±1.0% | S-1721A122J-I6T1x | - |
| 1.2 V ±15 mV | 3.0 V ±1.0% | S-1721A1230-I6T1x | - |
| 1.2 V ±15 mV | 3.3 V ±1.0% | S-1721A1233-I6T1x | S-1721A1233-M6T1x |
| 1.25 V ±15 mV | 1.8 V ±1.0% | S-1721A1C18-I6T1x | - |
| 1.3 V ±15 mV | 2.8 V ±1.0% | - | S-1721A1328-M6T1x |
| 1.3 V ±15 mV | 3.0 V ±1.0% | - | S-1721A1330-M6T1x |
| 1.5 V ±1.0% | 1.2 V ±15 mV | S-1721A1512-I6T1x | - |
| 1.5 V ±1.0% | 1.3 V ±15 mV | S-1721A1513-I6T1x | - |
| 1.5 V ±1.0% | 1.5 V ±1.0% | S-1721A1515-I6T1x | - |
| 1.5 V ±1.0% | 1.8 V ±1.0% | S-1721A1518-I6T1x | - |
| 1.5 V ±1.0% | 2.5 V ±1.0% | S-1721A1525-I6T1x | - |
| 1.5 V ±1.0% | 2.8 V ±1.0% | - | S-1721A1528-M6T1x |
| 1.5 V ±1.0% | 2.85 V ±1.0% | S-1721A152J-I6T1x | - |
| 1.5 V ±1.0% | 3.0 V ±1.0% | S-1721A1530-I6T1x | S-1721A1530-M6T1x |
| 1.5 V ±1.0% | 3.3 V ±1.0% | S-1721A1533-I6T1x | S-1721A1533-M6T1x |
| 1.8 V ±1.0% | 1.2 V ±15 mV | S-1721A1812-I6T1x | - |
| 1.8 V ±1.0% | 1.5 V ±1.0% | S-1721A1815-I6T1x | - |
| 1.8 V ±1.0% | 1.8 V ±1.0% | S-1721A1818-I6T1x | - |
| 1.8 V ±1.0% | 2.5 V ±1.0% | S-1721A1825-I6T1x | S-1721A1825-M6T1x |
| 1.8 V ±1.0% | 2.6 V ±1.0% | S-1721A1826-I6T1x | - |
| 1.8 V ±1.0% | 2.8 V ±1.0% | S-1721A1828-I6T1x | S-1721A1828-M6T1x |
| 1.8 V ±1.0% | 2.9 V ±1.0% | S-1721A1829-I6T1x | - |
| 1.8 V ±1.0% | 2.85 V ±1.0% | S-1721A182J-I6T1x | - |
| 1.8 V ±1.0% | 3.0 V ±1.0% | S-1721A1830-I6T1x | S-1721A1830-M6T1x |
| 1.8 V ±1.0% | 3.3 V ±1.0% | S-1721A1833-I6T1x | S-1721A1833-M6T1x |
| 2.0 V ±1.0% | 2.0 V ±1.0% | S-1721A2020-I6T1x | S-1721A2020-M6T1x |
| 2.1 V ±1.0% | 2.1 V ±1.0% | S-1721A2121-I6T1x | - |
| 2.5 V ±1.0% | 1.2 V ±15 mV | S-1721A2512-I6T1x | - |
| 2.5 V ±1.0% | 1.5 V ±1.0% | S-1721A2515-I6T1x | - |
| 2.5 V ±1.0% | 1.8 V ±1.0% | S-1721A2518-I6T1x | S-1721A2518-M6T1x |

Table 2 (2 / 2)

| Voltage Regulator 1 Output Voltage | Voltage Regulator 2 Output Voltage | SNT-6A | SOT-23-6 |
|------------------------------------|------------------------------------|-------------------|-------------------|
| 2.5 V \pm 1.0% | 2.5 V \pm 1.0% | S-1721A2525-I6T1x | - |
| 2.5 V \pm 1.0% | 2.8 V \pm 1.0% | S-1721A2528-I6T1x | S-1721A2528-M6T1x |
| 2.5 V \pm 1.0% | 2.85 V \pm 1.0% | S-1721A252J-I6T1x | - |
| 2.5 V \pm 1.0% | 3.0 V \pm 1.0% | S-1721A2530-I6T1x | - |
| 2.5 V \pm 1.0% | 3.3 V \pm 1.0% | S-1721A2533-I6T1x | - |
| 2.6 V \pm 1.0% | 1.3 V \pm 15 mV | S-1721A2613-I6T1x | - |
| 2.8 V \pm 1.0% | 1.2 V \pm 15 mV | S-1721A2812-I6T1x | S-1721A2812-M6T1x |
| 2.8 V \pm 1.0% | 1.5 V \pm 1.0% | S-1721A2815-I6T1x | S-1721A2815-M6T1x |
| 2.8 V \pm 1.0% | 1.8 V \pm 1.0% | S-1721A2818-I6T1x | S-1721A2818-M6T1x |
| 2.8 V \pm 1.0% | 2.5 V \pm 1.0% | S-1721A2825-I6T1x | - |
| 2.8 V \pm 1.0% | 2.6 V \pm 1.0% | S-1721A2826-I6T1x | - |
| 2.8 V \pm 1.0% | 2.8 V \pm 1.0% | S-1721A2828-I6T1x | S-1721A2828-M6T1x |
| 2.8 V \pm 1.0% | 2.85 V \pm 1.0% | S-1721A282J-I6T1x | - |
| 2.8 V \pm 1.0% | 3.0 V \pm 1.0% | S-1721A2830-I6T1x | S-1721A2830-M6T1x |
| 2.8 V \pm 1.0% | 3.3 V \pm 1.0% | S-1721A2833-I6T1x | S-1721A2833-M6T1x |
| 2.85 V \pm 1.0% | 1.2 V \pm 15 mV | S-1721A2J12-I6T1x | - |
| 2.85 V \pm 1.0% | 1.5 V \pm 1.0% | S-1721A2J15-I6T1x | - |
| 2.85 V \pm 1.0% | 1.8 V \pm 1.0% | S-1721A2J18-I6T1x | - |
| 2.85 V \pm 1.0% | 2.85 V \pm 1.0% | S-1721A2J2J-I6T1x | S-1721A2J2J-M6T1x |
| 2.85 V \pm 1.0% | 3.3 V \pm 1.0% | S-1721A2J33-I6T1x | - |
| 3.0 V \pm 1.0% | 1.8 V \pm 1.0% | S-1721A3018-I6T1x | - |
| 3.0 V \pm 1.0% | 2.8 V \pm 1.0% | S-1721A3028-I6T1x | - |
| 3.0 V \pm 1.0% | 3.0 V \pm 1.0% | S-1721A3030-I6T1x | - |
| 3.0 V \pm 1.0% | 3.3 V \pm 1.0% | S-1721A3033-I6T1x | - |
| 3.1 V \pm 1.0% | 1.9 V \pm 1.0% | S-1721A3119-I6T1x | - |
| 3.3 V \pm 1.0% | 1.2 V \pm 15 mV | - | S-1721A3312-M6T1x |
| 3.3 V \pm 1.0% | 1.8 V \pm 1.0% | S-1721A3318-I6T1x | S-1721A3318-M6T1x |
| 3.3 V \pm 1.0% | 2.8 V \pm 1.0% | - | S-1721A3328-M6T1x |
| 3.3 V \pm 1.0% | 3.0 V \pm 1.0% | S-1721A3330-I6T1x | - |
| 3.3 V \pm 1.0% | 3.3 V \pm 1.0% | S-1721A3333-I6T1x | S-1721A3333-M6T1x |

Remark 1. Please contact our sales office for products with specifications other than the above.

2. x: G or U

3. Please select products of environmental code = U for Sn 100%, halogen-free products.

4.2 S-1721 series B type

ON/OFF logic : 1ch : Active "H", 2ch : Active "L"
 Pull-up resistor : 1ch : None, 2ch : Available
 Pull-down resistor : 1ch : Available, 2ch : None

Table 3

| Voltage Regulator 1 Output Voltage | Voltage Regulator 2 Output Voltage | SNT-6A | SOT-23-6 |
|------------------------------------|------------------------------------|-------------------|-------------------|
| 1.5 V ±1.0% | 1.5 V ±1.0% | S-1721B1515-I6T1x | – |
| 1.5 V ±1.0% | 1.8 V ±1.0% | S-1721B1518-I6T1x | – |
| 1.8 V ±1.0% | 1.2 V ±15 mV | S-1721B1812-I6T1x | – |
| 1.8 V ±1.0% | 1.8 V ±1.0% | S-1721B1818-I6T1x | – |
| 2.8 V ±1.0% | 1.8 V ±1.0% | S-1721B2818-I6T1x | – |
| 2.8 V ±1.0% | 2.8 V ±1.0% | – | S-1721B2828-M6T1x |
| 2.85 V ±1.0% | 2.85 V ±1.0% | S-1721B2J2J-I6T1x | – |

4.3 S-1721 series C type

ON/OFF logic : 1ch : Active "L", 2ch : Active "H"
 Pull-up resistor : 1ch : Available, 2ch : None
 Pull-down resistor : 1ch : None, 2ch : Available

Table 4

| Voltage Regulator 1 Output Voltage | Voltage Regulator 2 Output Voltage | SNT-6A | SOT-23-6 |
|------------------------------------|------------------------------------|-------------------|-------------------|
| 2.85 V ±1.0% | 2.85 V ±1.0% | S-1721C2J2J-I6T1x | S-1721C2J2J-M6T1x |

4.4 S-1721 series D type

ON/OFF logic : 1ch : Active "L", 2ch : Active "L"
 Pull-up resistor : 1ch : Available, 2ch : Available
 Pull-down resistor : 1ch : None, 2ch : None

Table 5

| Voltage Regulator 1 Output Voltage | Voltage Regulator 2 Output Voltage | SNT-6A | SOT-23-6 |
|------------------------------------|------------------------------------|-------------------|-------------------|
| 1.8 V ±1.0% | 1.8 V ±1.0% | S-1721D1818-I6T1x | – |
| 1.8 V ±1.0% | 2.8 V ±1.0% | – | S-1721D1828-M6T1x |
| 3.3 V ±1.0% | 1.8 V ±1.0% | S-1721D3318-I6T1x | S-1721D3318-M6T1x |

- Remark 1.** Please contact our sales office for products with specifications other than the above.
2. x: G or U
3. Please select products of environmental code = U for Sn 100%, halogen-free products.

4.5 S-1721 series E type

ON/OFF logic : 1ch : Active "H", 2ch : Active "H"
 Pull-up resistor : 1ch : None, 2ch : None
 Pull-down resistor : 1ch : None, 2ch : None

Table 6

| Voltage Regulator 1 Output Voltage | Voltage Regulator 2 Output Voltage | SNT-6A | SOT-23-6 |
|---------------------------------------|---------------------------------------|-------------------|-------------------|
| 1.3 V \pm 15 mV | 2.8 V \pm 1.0% | S-1721E1328-I6T1x | - |
| 1.5 V \pm 1.0% | 2.8 V \pm 1.0% | S-1721E1528-I6T1x | S-1721E1528-M6T1x |
| 1.8 V \pm 1.0% | 2.5 V \pm 1.0% | - | S-1721E1825-M6T1x |
| 1.8 V \pm 1.0% | 2.6 V \pm 1.0% | - | S-1721E1826-M6T1x |
| 1.8 V \pm 1.0% | 2.8 V \pm 1.0% | S-1721E1828-I6T1x | S-1721E1828-M6T1x |
| 1.8 V \pm 1.0% | 3.0 V \pm 1.0% | - | S-1721E1830-M6T1x |
| 1.8 V \pm 1.0% | 3.3 V \pm 1.0% | S-1721E1833-I6T1x | S-1721E1833-M6T1x |
| 2.0 V \pm 1.0% | 2.5 V \pm 1.0% | - | S-1721E2025-M6T1x |
| 2.5 V \pm 1.0% | 1.8 V \pm 1.0% | S-1721E2518-I6T1x | - |
| 2.5 V \pm 1.0% | 2.5 V \pm 1.0% | S-1721E2525-I6T1x | - |
| 2.5 V \pm 1.0% | 3.0 V \pm 1.0% | S-1721E2530-I6T1x | - |
| 2.8 V \pm 1.0% | 1.3 V \pm 15 mV | - | S-1721E2813-M6T1x |
| 2.8 V \pm 1.0% | 1.8 V \pm 1.0% | S-1721E2818-I6T1x | S-1721E2818-M6T1x |
| 2.8 V \pm 1.0% | 3.3 V \pm 1.0% | S-1721E2833-I6T1x | S-1721E2833-M6T1x |
| 2.85 V \pm 1.0% | 2.5 V \pm 1.0% | S-1721E2J25-I6T1x | S-1721E2J25-M6T1x |
| 2.85 V \pm 1.0% | 2.85 V \pm 1.0% | S-1721E2J2J-I6T1x | - |
| 3.0 V \pm 1.0% | 1.2 V \pm 15 mV | S-1721E3012-I6T1x | - |
| 3.0 V \pm 1.0% | 2.5 V \pm 1.0% | S-1721E3025-I6T1x | - |
| 3.0 V \pm 1.0% | 3.3 V \pm 1.0% | S-1721E3033-I6T1x | - |
| 3.3 V \pm 1.0% | 1.2 V \pm 15 mV | - | S-1721E3312-M6T1x |

- Remark 1.** Please contact our sales office for products with specifications other than the above.
2. x: G or U
3. Please select products of environmental code = U for Sn 100%, halogen-free products.

■ Pin Configurations

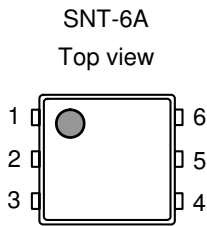

Figure 9

Table 7

| Pin No. | Symbol | Description |
|---------|---------|----------------------|
| 1 | ON/OFF2 | ON/OFF pin 2 |
| 2 | VIN | Input voltage pin |
| 3 | ON/OFF1 | ON/OFF pin 1 |
| 4 | VSS | GND pin |
| 5 | VOUT1 | Output voltage pin 1 |
| 6 | VOUT2 | Output voltage pin 2 |

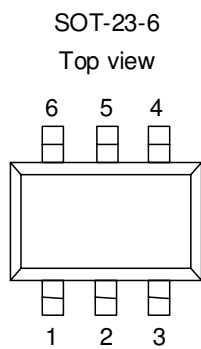

Figure 10

Table 8

| Pin No. | Symbol | Description |
|---------|---------|----------------------|
| 1 | ON/OFF1 | ON/OFF pin 1 |
| 2 | VIN | Input voltage pin |
| 3 | ON/OFF2 | ON/OFF pin 2 |
| 4 | VOUT2 | Output voltage pin 2 |
| 5 | VSS | GND pin |
| 6 | VOUT1 | Output voltage pin 1 |

■ Absolute Maximum Ratings

Table 9

(Ta = 25°C unless otherwise specified)

| Item | Symbol | Absolute Maximum Rating | Unit |
|-------------------------------|-----------------|----------------------------------|------|
| Input voltage | V_{IN} | $V_{SS} - 0.3$ to $V_{SS} + 7.0$ | V |
| | $V_{ON/OFF1,2}$ | $V_{SS} - 0.3$ to $V_{IN} + 0.3$ | V |
| Output voltage | $V_{OUT1,2}$ | $V_{SS} - 0.3$ to $V_{IN} + 0.3$ | V |
| Power dissipation | P_D | 400*1 | mW |
| | | 650*1 | mW |
| Operating ambient temperature | T_{opr} | -40 to +85 | °C |
| Storage temperature | T_{stg} | -40 to +125 | °C |

*1. When mounted on board

[Mounted board]

- (1) Board size : 114.3 mm × 76.2 mm × t1.6 mm
- (2) Board name : JEDEC STANDARD51-7

Caution The absolute maximum ratings are rated values exceeding which the product could suffer physical damage. These values must therefore not be exceeded under any conditions.

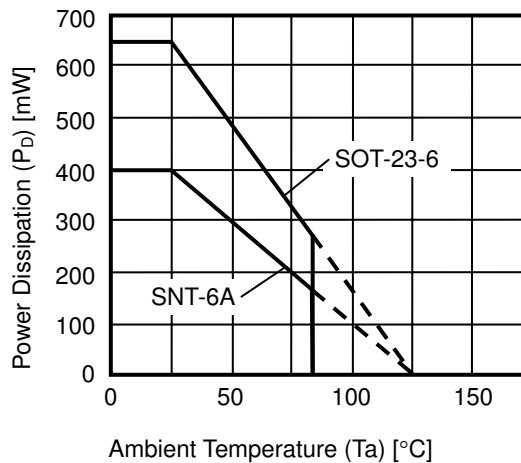

Figure 11 Power Dissipation of Package (when mounted on board)

■ **Electrical Characteristics**

Table 10

Voltage regulator 1 and voltage regulator 2 (per circuit)

(Ta = 25°C unless otherwise specified)

| Item | Symbol | Conditions | Min. | Typ. | Max. | Unit | Test Circuit | |
|--|---|---|-------------------------------------|--------------------------------|---------------------|--------------------------------|--------------|------|
| Output voltage ^{*1} | V _{OUT(E)} | V _{IN} = V _{OUT(S)} + 1.0 V, I _{OUT} = 30 mA | 1.2 V ≤ V _{OUT(S)} < 1.5 V | V _{OUT(S)} − 0.015 | V _{OUT(S)} | V _{OUT(S)} + 0.015 | V | 2, 3 |
| | | | 1.5 V ≤ V _{OUT(S)} ≤ 5.0 V | V _{OUT(S)} × 0.99 | V _{OUT(S)} | V _{OUT(S)} × 1.01 | V | 2, 3 |
| Output current ^{*2} | I _{OUT} | V _{IN} ≥ V _{OUT(S)} + 1.0 V | 150 ^{*5} | — | — | mA | 4, 5 | |
| Dropout voltage ^{*3} | V _{drop} | I _{OUT} = 100 mA | 1.2 V ≤ V _{OUT(S)} < 1.3 V | 0.50 | 0.54 | 0.58 | V | 2, 3 |
| | | | 1.3 V ≤ V _{OUT(S)} < 1.4 V | 0.40 | 0.44 | 0.48 | V | 2, 3 |
| | | | 1.4 V ≤ V _{OUT(S)} < 1.5 V | 0.30 | 0.34 | 0.39 | V | 2, 3 |
| | | | 1.5 V ≤ V _{OUT(S)} < 1.7 V | — | 0.26 | 0.39 | V | 2, 3 |
| | | | 1.7 V ≤ V _{OUT(S)} < 2.0 V | — | 0.20 | 0.35 | V | 2, 3 |
| | | | 2.0 V ≤ V _{OUT(S)} < 2.8 V | — | 0.16 | 0.24 | V | 2, 3 |
| | | 2.8 V ≤ V _{OUT(S)} ≤ 5.0 V | — | 0.13 | 0.23 | V | 2, 3 | |
| Line regulation | $\frac{\Delta V_{OUT1}}{\Delta V_{IN} \bullet V_{OUT}}$ | V _{OUT(S)} + 0.5 V ≤ V _{IN} ≤ 6.5 V, I _{OUT} = 30 mA | — | 0.05 | 0.2 | %/V | 2, 3 | |
| Load regulation | ΔV_{OUT2} | V _{IN} = V _{OUT(S)} + 1.0 V, 100 μA ≤ I _{OUT} ≤ 100 mA | — | 20 | 40 | mV | 2, 3 | |
| Output voltage temperature coefficient ^{*4} | $\frac{\Delta V_{OUT}}{\Delta T_a \bullet V_{OUT}}$ | V _{IN} = V _{OUT(S)} + 1.0 V, I _{OUT} = 30 mA, −40°C ≤ Ta ≤ +85°C | — | ±120 | — | ppm/°C | 2, 3 | |
| Current consumption during operation (per circuit) | I _{SS1} | V _{IN} = V _{OUT(S)} + 1.0 V, ON/OFF pin = ON, no load 1.2 V ≤ V _{OUT(S)} < 1.5 V | — | 35 | 45 | μA | 1 | |
| | | V _{IN} = V _{OUT(S)} + 1.0 V, ON/OFF pin = ON, no load 1.5 V ≤ V _{OUT(S)} < 1.8 V | — | 32 | 45 | μA | 1 | |
| | | V _{IN} = V _{OUT(S)} + 1.0 V, ON/OFF pin = ON, no load 1.8 V ≤ V _{OUT(S)} ≤ 5.0 V | — | 25 | 45 | μA | 1 | |
| Current consumption during shutdown | I _{SS2} | V _{IN} = V _{OUT(S)} + 1.0 V, ON/OFF pin = OFF, no load | — | 0.1 | 1.0 | μA | 1 | |
| Input voltage | V _{IN} | — | 1.7 | — | 6.5 | V | 1 | |
| ON/OFF pin input voltage "H" | V _{SH} | V _{IN} = V _{OUT(S)} + 1.0 V, R _L = 1.0 kΩ | 1.2 | — | — | V | 6, 7 | |
| ON/OFF pin input voltage "L" | V _{SL} | V _{IN} = V _{OUT(S)} + 1.0 V, R _L = 1.0 kΩ | — | — | 0.3 | V | 6, 7 | |
| ON/OFF pin input current "H" | I _{SH} | V _{IN} = 6.5 V, V _{ON/OFF} = 6.5 V | B (2ch)/C (1ch)/D/E/F/G/H type | −0.1 | — | 0.1 | μA | 6, 7 |
| | | | A/B (1ch)/C (2ch) type | 1.0 | 2.5 | 4.2 | μA | |
| ON/OFF pin input current "L" | I _{SL} | V _{IN} = 6.5 V, V _{ON/OFF} = 0 V | A/B (1ch)/C (2ch)/E/F/G/H type | −0.1 | — | 0.1 | μA | 6, 7 |
| | | | B (2ch)/C (1ch)/D type | 1.0 | 2.5 | 4.2 | μA | |
| Ripple rejection | RR | V _{IN} = V _{OUT(S)} + 1.0 V, f = 1.0 kHz, ΔV _{rip} = 0.5 Vrms, I _{OUT} = 30 mA | 1.2 V ≤ V _{OUT(S)} < 1.8 V | — | 80 | — | dB | 8, 9 |
| | | | 1.8 V ≤ V _{OUT(S)} < 3.1 V | — | 75 | — | dB | 8, 9 |
| | | | 3.1 V ≤ V _{OUT(S)} ≤ 5.0 V | — | 70 | — | dB | 8, 9 |
| Short-circuit current | I _{short} | V _{IN} = V _{OUT(S)} + 1.0 V, ON/OFF pin = ON, V _{OUT} = 0 V | — | 150 | — | mA | 4, 5 | |
| Shutdown pull-up/pull-down resistor | R _{PD} | — | 1.5 | 2.6 | 6.5 | MΩ | 6, 7 | |

- *1. $V_{OUT(S)}$: Specified output voltage
 $V_{OUT(E)}$: Actual output voltage at the fixed load
 Output voltage when fixing $I_{OUT}(= 30 \text{ mA})$ and inputting $V_{OUT(S)} + 1.0 \text{ V}$
- *2. The output current at which the output voltage becomes 95% of $V_{OUT(E)}$ after gradually increasing the output current.
- *3. $V_{drop} = V_{IN1} - (V_{OUT3} \times 0.98)$
 V_{OUT3} is the output voltage when $V_{IN} = V_{OUT(S)} + 1.0 \text{ V}$ and $I_{OUT} = 100 \text{ mA}$.
 V_{IN1} is the input voltage at which the output voltage becomes 98% of V_{OUT3} after gradually decreasing the input voltage.
- *4. The change in temperature [$\text{mV}/^\circ\text{C}$] is calculated using the following equation.

$$\frac{\Delta V_{OUT}}{\Delta T_a} [\text{mV}/^\circ\text{C}]^*1 = V_{OUT(S)} [\text{V}]^*2 \times \frac{\Delta V_{OUT}}{\Delta T_a \bullet V_{OUT}} [\text{ppm}/^\circ\text{C}]^*3 \div 1000$$
 - *1. Change in temperature of the output voltage
 - *2. Specified output voltage
 - *3. Output voltage temperature coefficient
- *5. The output current can be at least this value.
 Due to restrictions on the package power dissipation, this value may not be satisfied. Attention should be paid to the power dissipation of the package when the output current is large.
 This specification is guaranteed by design.

■ Test Circuit

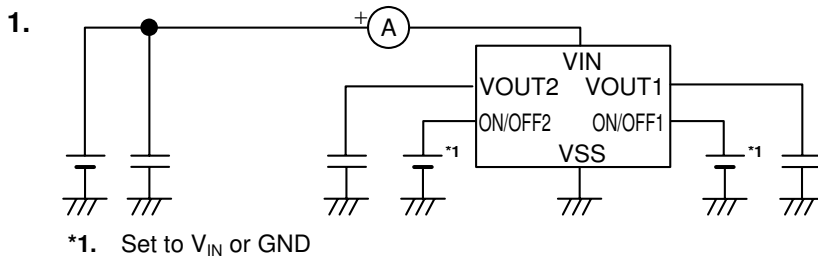

Figure 12

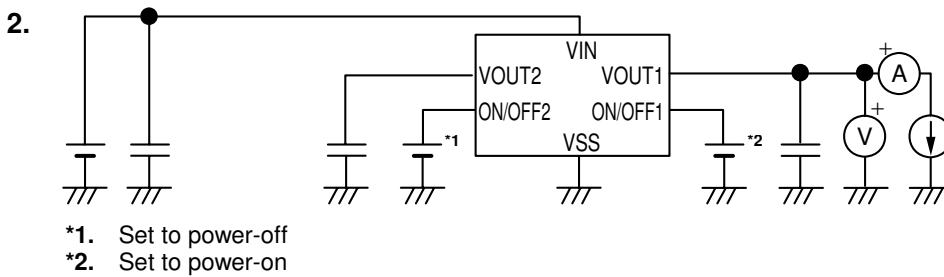

Figure 13

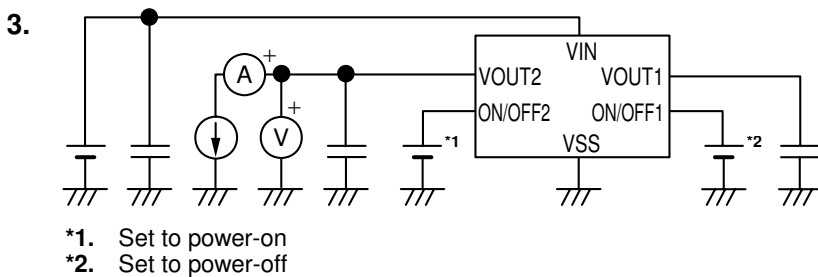

Figure 14

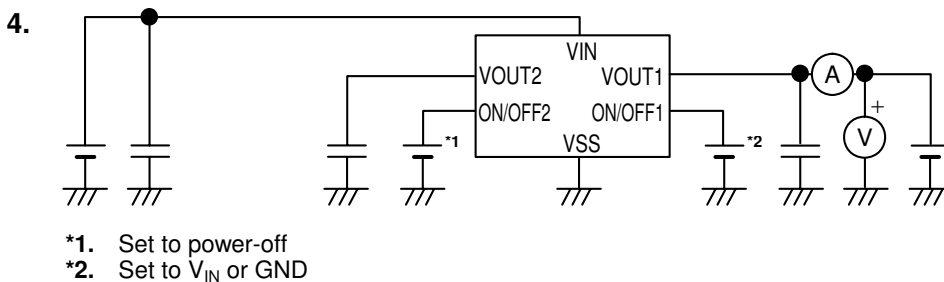

Figure 15

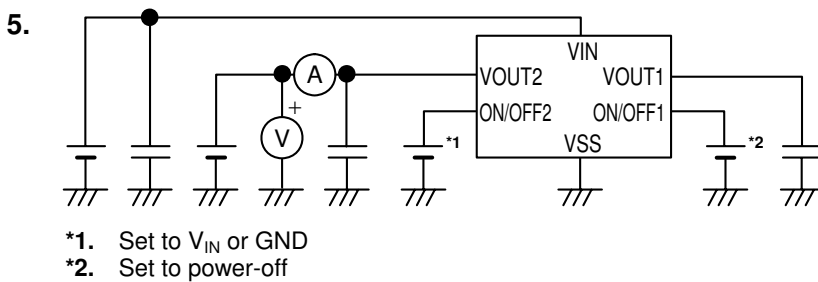

Figure 16

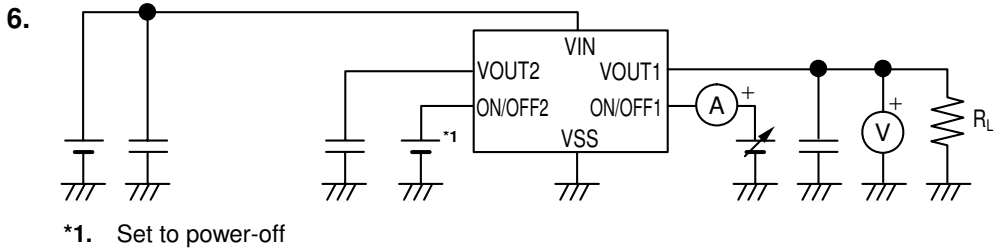

Figure 17

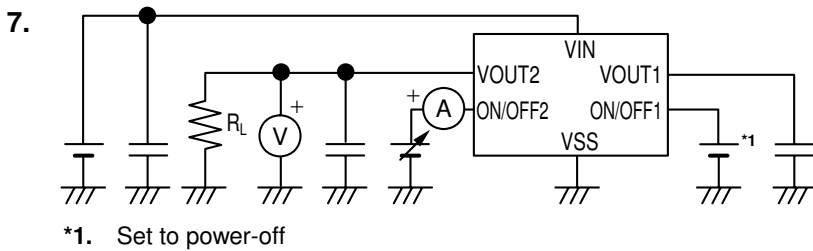

Figure 18

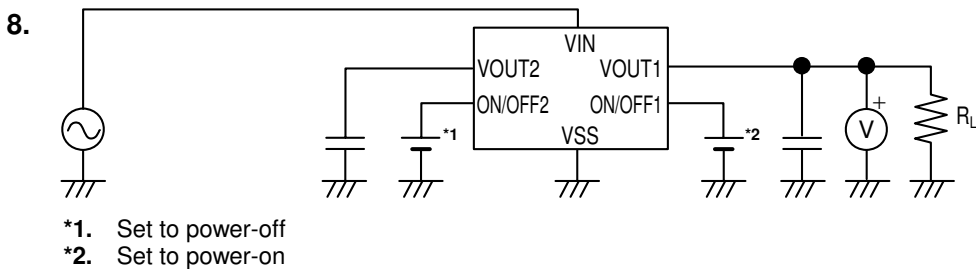

Figure 19

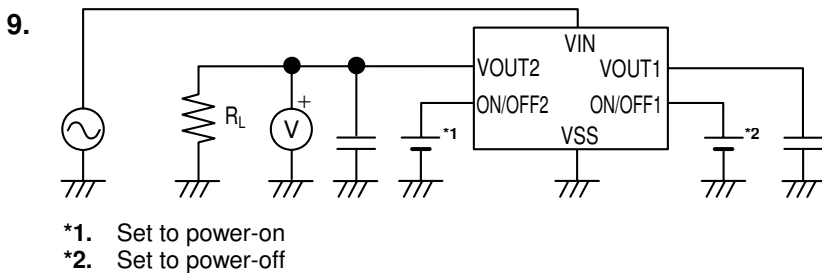
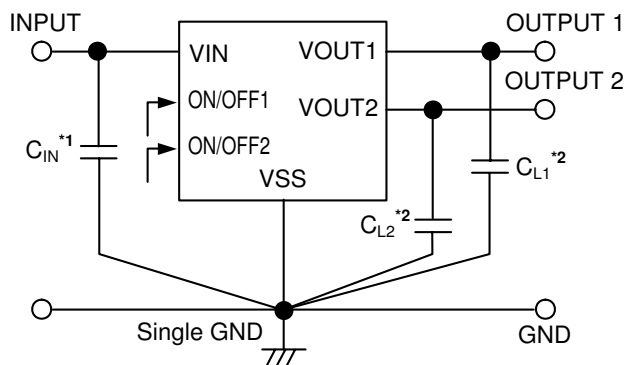

Figure 20

■ **Standard Circuit**



- *1. C_{IN} is a capacitor for stabilizing the input.
- *2. A ceramic capacitor of 1.0 μF or more can be used for C_{L1} and C_{L2} .

Figure 21

Caution The above connection diagram and constant will not guarantee successful operation. Perform thorough evaluation using the actual application to set the constant.

■ **Condition of Application**

- Input capacitor (C_{IN}) : 1.0 μF or more
- Output capacitor (C_{L1}, C_{L2}) : 1.0 μF or more (ceramic capacitor)

Caution A general series regulator may oscillate, depending on the external components. Confirm that no oscillation occurs in the application for which the above capacitors are used.

■ **Selection of Input and Output Capacitors (C_{IN}, C_{L1}, C_{L2})**

The S-1721 Series requires an output capacitor between the VOUT and VSS pin for phase compensation. Operation is stabilized by a ceramic capacitor with an output capacitance of 1.0 μF or more over the entire temperature range. When using an OS capacitor, tantalum capacitor, or aluminum electrolytic capacitor, the capacitance must be 1.0 μF or more.

The value of the output overshoot or undershoot transient response varies depending on the value of the output capacitor. The required capacitance of the input capacitor differs depending on the application.

The recommended capacitance for an application is $C_{IN} \geq 1.0 \mu\text{F}$, $C_{L1} \geq 1.0 \mu\text{F}$, $C_{L2} \geq 1.0 \mu\text{F}$; however, when selecting the output capacitor, perform sufficient evaluation, including evaluation of temperature characteristics, on the actual device.

■ Explanation of Terms

1. Low dropout voltage regulator

This IC's voltage regulator has the low dropout voltage due to its built-in low on-resistance transistor.

2. Output voltage (V_{OUT})

The accuracy of the output voltage is ensured at $\pm 1.0\%$ under the specified conditions of fixed input voltage^{*1}, fixed output current, and fixed temperature.

*1. Differs depending on the product.

Caution If the above conditions change, the output voltage value may vary and exceed the accuracy range of the output voltage. See “■ Electrical Characteristics” and “■ Characteristics (Typical Data) (Per Circuit)” for details.

3. Line regulation $\left(\frac{\Delta V_{OUT1}}{\Delta V_{IN} \bullet V_{OUT}} \right)$

Indicates the dependency of the output voltage on the input voltage. That is, the values show how much the output voltage changes due to a change in the input voltage with the output current remaining unchanged.

4. Load regulation (ΔV_{OUT2})

Indicates the dependency of the output voltage on the output current. That is, the values show how much the output voltage changes due to a change in the output current with the input voltage remaining unchanged.

5. Dropout voltage (V_{drop})

Indicates the difference between input voltage V_{IN} and the output voltage when; decreasing input voltage V_{IN} gradually until the output voltage has dropped out to the value of 98% of output voltage V_{OUT3} , which is at $V_{IN} = V_{OUT(S)} + 1.0$ V.

$$V_{drop} = V_{IN1} - (V_{OUT3} \times 0.98)$$

6. Temperature coefficient of output voltage $\left(\frac{\Delta V_{OUT}}{\Delta T_a \bullet V_{OUT}} \right)$

The shaded area in **Figure 22** is the range where V_{OUT} varies in the operating temperature range when the temperature coefficient of the output voltage is ± 120 ppm/ $^{\circ}$ C.

Example of $V_{OUT} = 3.0$ V Typ. products

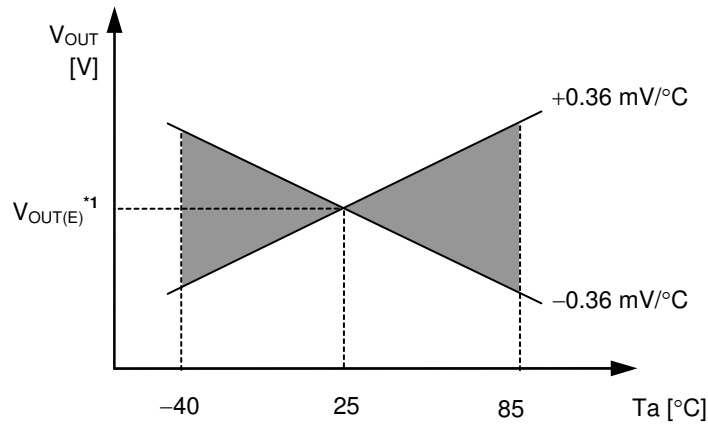

*1. $V_{OUT(E)}$ is the value of the output voltage measured at 25°C.

Figure 22

A change in the temperature of the output voltage [mV/ $^{\circ}$ C] is calculated using the following equation.

$$\frac{\Delta V_{OUT}}{\Delta T_a} [\text{mV}/^{\circ}\text{C}]^{*1} = V_{OUT(S)} [\text{V}]^{*2} \times \frac{\Delta V_{OUT}}{\Delta T_a \bullet V_{OUT}} [\text{ppm}/^{\circ}\text{C}]^{*3} \div 1000$$

- *1. Change in temperature of output voltage
- *2. Specified output voltage
- *3. Output voltage temperature coefficient

■ Operation

1. Basic operation

Figure 23 shows the block diagram of S-1721 Series.

The error amplifier compares the reference voltage (V_{ref}) with V_{fb} , which is the output voltage resistance-divided by feedback resistors R_s and R_f . It supplies the gate voltage necessary to maintain the constant output voltage which is not influenced by the input voltage and temperature change, to the output transistor.

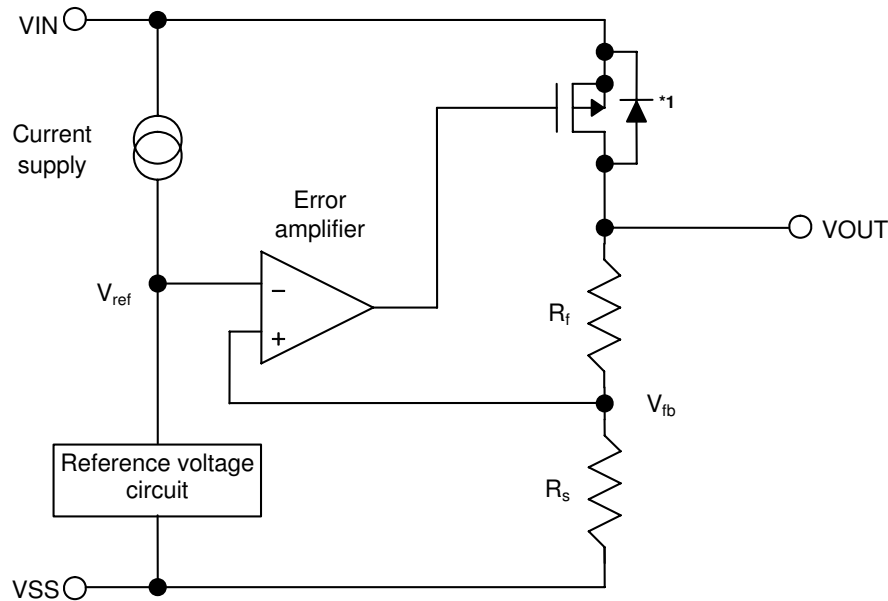

*1. Parasitic diode

Figure 23

2. Output transistor

In the S-1721 Series, a low on-resistance P-channel MOS FET is used as the output transistor.

Be sure that V_{OUT} does not exceed $V_{IN} + 0.3$ V to prevent the voltage regulator from being damaged due to inverse current flowing from the VOUT pin through a parasitic diode to the VIN pin.

3. ON/OFF pin 1 and 2

These pins start and stop the regulator.

When the ON/OFF pin is set to the power-off level, the entire internal circuit stops operating, and the built-in P-channel MOS FET output transistor between the VIN and VOUT pin is turned off, in order to reduce the current consumption significantly. The VOUT pin is set to the V_{SS} level by the internal dividing resistor of several hundred kΩ which is placed between the VOUT and VSS pin. Note that the current consumption increases when a voltage of 0.3 V to 1.2 V (@T_a = 25°C) is applied to the ON/OFF pin.

The ON/OFF pin is configured as shown in **Figures 24** and **25**. In the S-1721 Series A, B C, and D types, the ON/OFF pin is internally pulled up to VIN or pulled down to VSS when in the floating status, so the VOUT pin is set to the V_{SS} level.

In the S-1721 Series E, F, G and H types, do not use S-1721 Series in the floating status because the ON/OFF pin is not internally pulled up or pulled down.

When not using the ON/OFF pin in the S-1721 Series E, F, G, and H types, connect the ON/OFF pin to the VIN pin in the E, F (1ch only), and G (2ch only) types. In the F (2ch only), G (1ch only) and H types, connect the ON/OFF pin to the VSS pin.

Table 11

| Logic Type | ON/OFF Pin | Internal Circuits | VOUT Pin Voltage | Current Consumption |
|------------|--|--------------------|--|--------------------------------------|
| A | 1ch "H": Power on 2ch "H": Power on | Operate Operate | Set value Set value | I _{SS1} I _{SS1} |
| B | 1ch "H": Power on 2ch "L": Power on | Operate Operate | Set value Set value | I _{SS1} I _{SS1} |
| C | 1ch "L": Power on 2ch "H": Power on | Operate Operate | Set value Set value | I _{SS1} I _{SS1} |
| D | 1ch "L": Power on 2ch "L": Power on | Operate Operate | Set value Set value | I _{SS1} I _{SS1} |
| E | 1ch "L": Power off 2ch "L": Power off | Stop Stop | V _{SS} level V _{SS} level | I _{SS2} I _{SS2} |
| F | 1ch "L": Power off 2ch "H": Power off | Stop Stop | V _{SS} level V _{SS} level | I _{SS2} I _{SS2} |
| G | 1ch "H": Power off 2ch "L": Power off | Stop Stop | V _{SS} level V _{SS} level | I _{SS2} I _{SS2} |
| H | 1ch "H": Power off 2ch "H": Power off | Stop Stop | V _{SS} level V _{SS} level | I _{SS2} I _{SS2} |

(1) S-1721 Series A, B, C, D Types

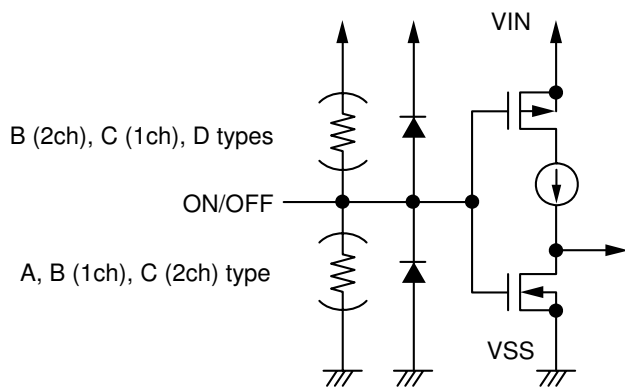

Figure 24

(2) S-1721 Series E, F, G, H Types

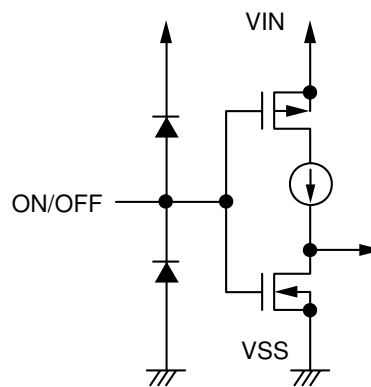

Figure 25

4. Overcurrent protector

The S-1721 Series has a built-in overcurrent protector having the characteristics shown in (1) Output Voltage vs. Output Current ($T_a = 25^\circ\text{C}$) in “■ Characteristics (Typical Data) (Per Circuit)” to protect the output transistor against an excessive output current and short circuiting between the VOUT and VSS pin.

The current (I_{short}) when the output pin is short-circuited is internally set at approximately 150 mA (Typ.), and the initial value is restored for the output voltage, if releasing a short circuit once.

Caution Note that the overcurrent protect circuit does not provide a thermal protection function, therefore pay attention to the conditions of input voltage and load current so that the IC's loss under the usage conditions, including the short circuit conditions, does not exceed the package power dissipation if the condition in which a short circuiting or large current state (150 mA or more) continues for a long time.

5. Pull-down/pull-up resistor (S-1721 Series A, B, C, and D types)

In the S-1721 Series A, B, C, and D types, the ON/OFF pin is internally pulled up to VIN or pulled down to VSS, so the VOUT pin is in the VSS level when in the floating status.

In A/B (1ch only) and C (2ch only), the ON/OFF pin is connected to VIN,

In B (2ch only)/C (1ch only)/D type, the ON/OFF pin is connected to VSS;

Note that during operation in these cases, the current consumption of the IC is generated as much as the current which flows into a pull-up resistor of 2.6 M Ω or a pull-down resistor of 2.6 M Ω .

■ Precautions

- Wiring patterns for the VIN, VOUT and GND pins should be designed so that the impedance is low. When mounting an output capacitor between the VOUT and VSS pin (C_{L1} , C_{L2}) and a capacitor for stabilizing the input between VIN and VSS pin (C_{IN}), the distance from the capacitors to these pins should be as short as possible.
- Note that the output voltage may increase when a series regulator is used at low load current (1.0 mA or less).
- Note that the output voltage may increase due to the leakage current from a driver when a series regulator is used at high temperature.
- Generally a series regulator may cause oscillation, depending on the selection of external parts. The following conditions are recommended for this IC. However, be sure to perform sufficient evaluation under the actual usage conditions for selection, including evaluation of temperature characteristics. See “**(5) Example of Equivalent Series Resistance vs. Output Current Characteristics (Ta = 25°C)**” in “**■ Reference Data (Per Circuit)**” for the equivalent series resistance (R_{ESR}) of the output capacitor.

| | |
|--|---------------------|
| Input capacitor (C_{IN}) : | 1.0 μ F or more |
| Output capacitor (C_{L1} , C_{L2}) : | 1.0 μ F or more |

- The voltage regulator may oscillate when the impedance of the power supply is high and the input capacitor is small or an input capacitor is not connected. Note that, if the capacitance of the output capacitor is greater than that of the input capacitor, the voltage regulator may oscillate.
- Note that an oscillation may occur when the load current is high (100 mA or higher) and the difference between the voltage input and output is around the dropout voltage if the inductance of the power supply is high. Perform sufficient evaluation including electrical characteristics under the actual use conditions to select an input capacitor.
- Concerning the fluctuation of output voltage due to power-supplying and load, confirm with the actual device.
- If the power supply suddenly increases, a momentary overshoot may be output. It is therefore important to sufficiently evaluate the output voltage at power application in the actual equipment.
- The application conditions for the input voltage, output voltage, and load current should not exceed the package power dissipation.
- Do not apply an electrostatic discharge to this IC that exceeds the performance ratings of the built-in electrostatic protection circuit.
- In determining the output current, attention should be paid to the output current value specified in **Table 10** in “**■ Electrical Characteristics**” and footnote *5 of the table.
- SII claims no responsibility for any disputes arising out of or in connection with any infringement by products including this IC of patents owned by a third party.

■ Characteristics (Typical Data) (Per Circuit)

(1) Output Voltage vs. Output Current (When Load Current Increases) (Ta = 25°C)

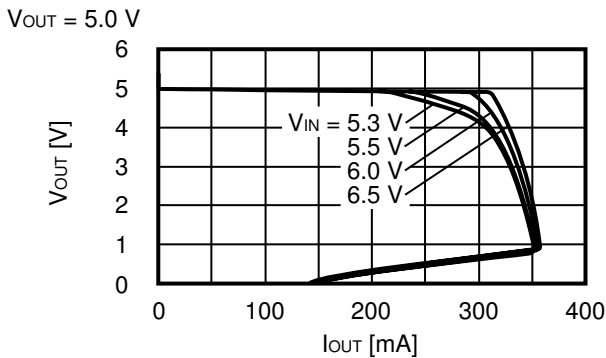
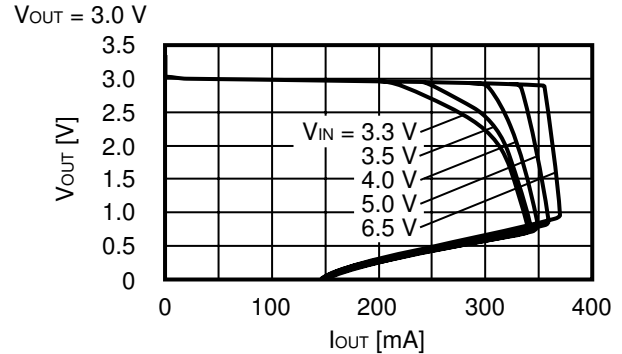
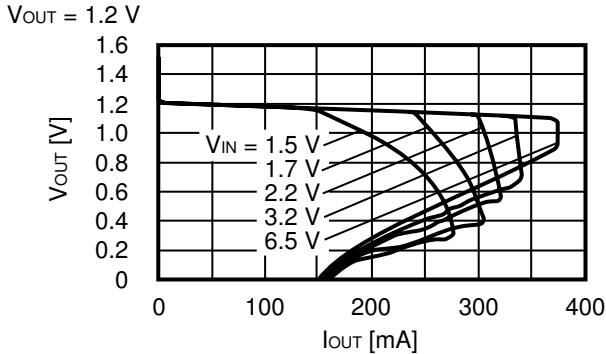

Remark In determining the output current, attention should be paid to the following.

1. The minimum output current value and footnote *5 in Table 10 in the “■ Electrical Characteristics”
2. The package power dissipation

(2) Output Voltage vs. Input Voltage (Ta = 25°C)

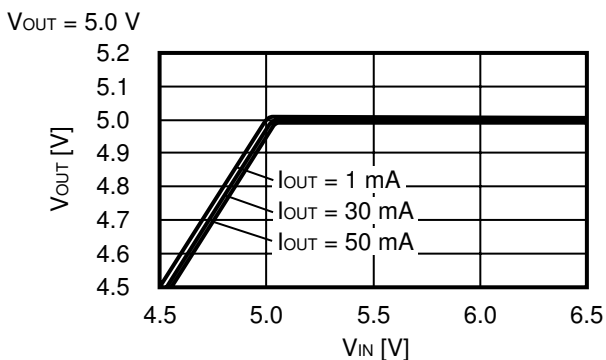
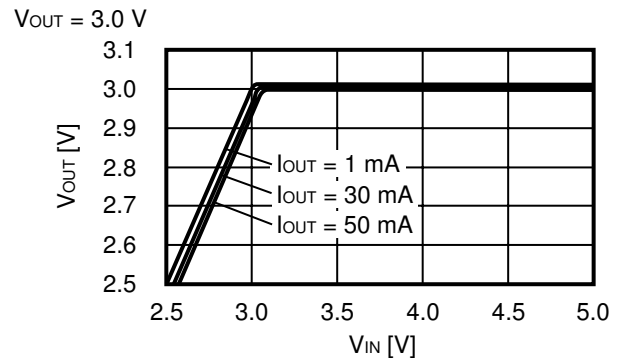
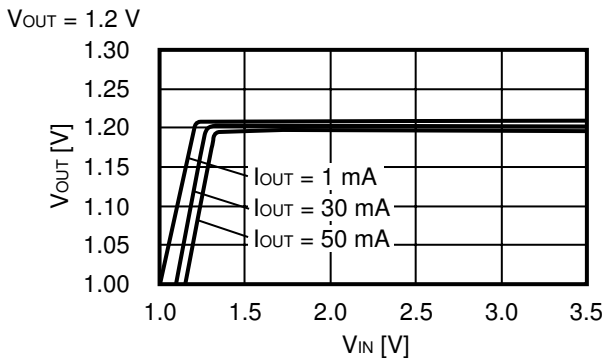

(3) Dropout Voltage vs. Output Current

$V_{OUT} = 1.2\text{ V}$

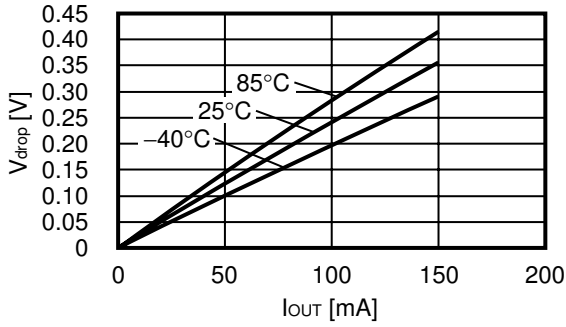

$V_{OUT} = 3.0\text{ V}$

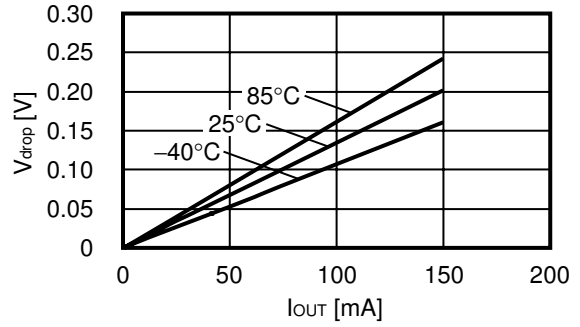

$V_{OUT} = 5.0\text{ V}$

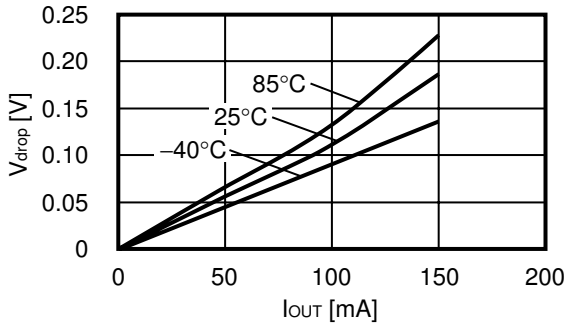

(4) Dropout Voltage vs. Set Output Voltage

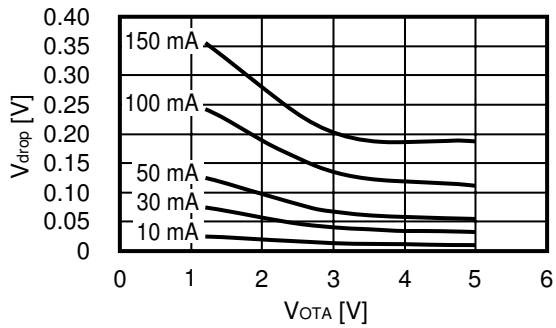

(5) Output Voltage vs. Ambient Temperature

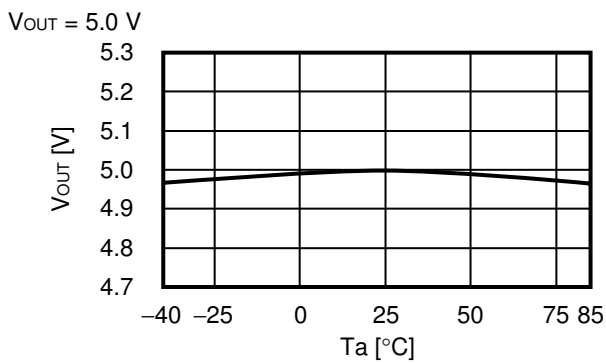
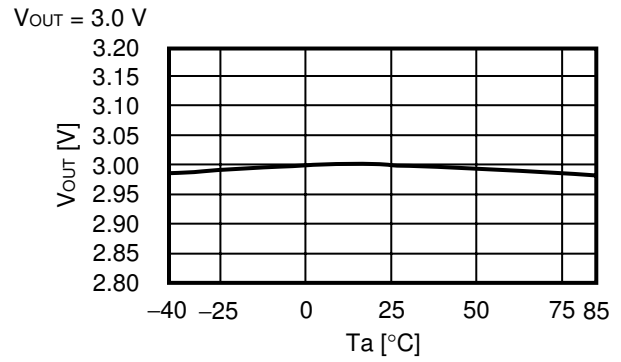
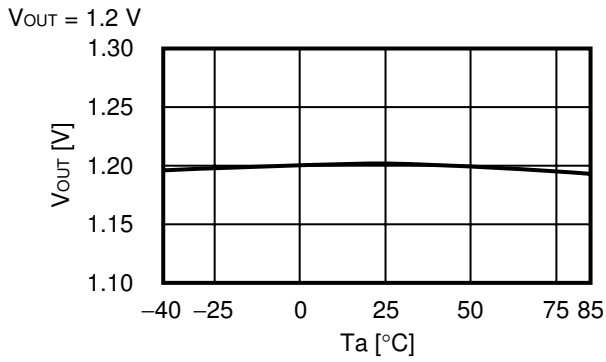

(6) Current Consumption vs. Input Voltage

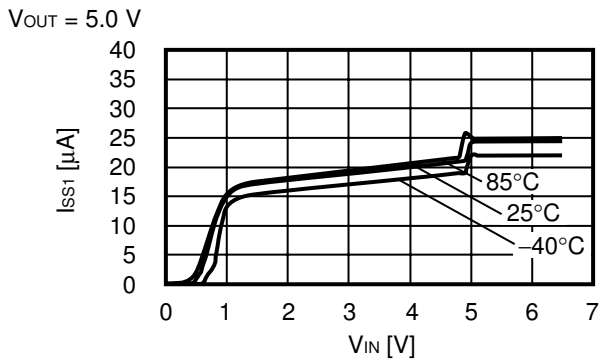
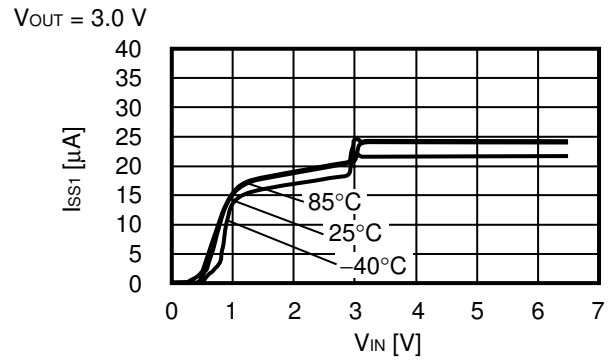
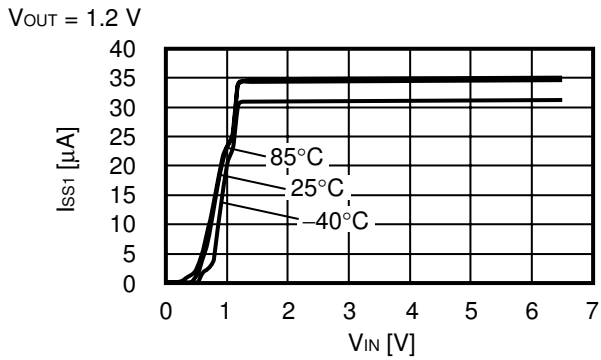

(7) Ripple Rejection (Ta = 25°C)

V_{OUT} = 1.2 V

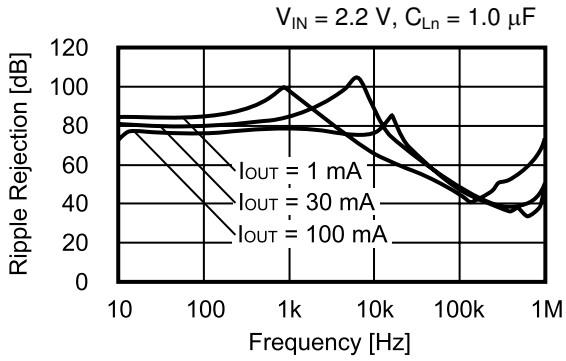

V_{OUT} = 3.0 V

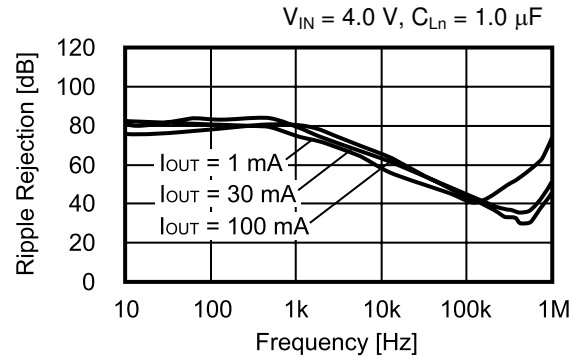

V_{OUT} = 5.0 V

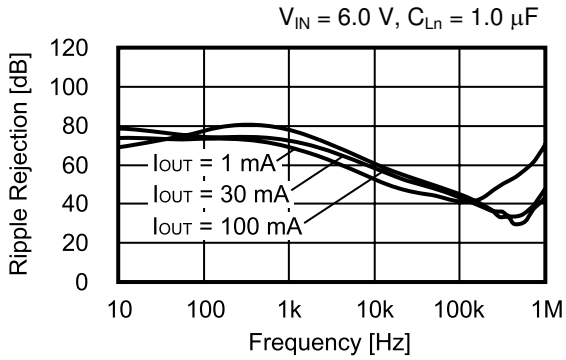

Remark C_{Ln}: Capacitor set to VOUTn pin externally (n = 1, 2)

■ Reference Data (Per Circuit)

(1) Transient Response Characteristics when Input ($T_a = 25^\circ\text{C}$) Common to VR1 and VR2

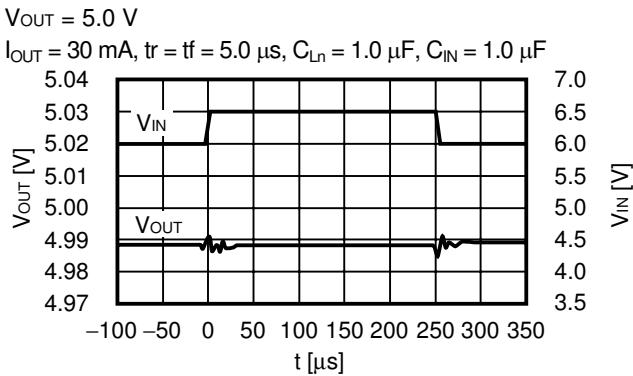
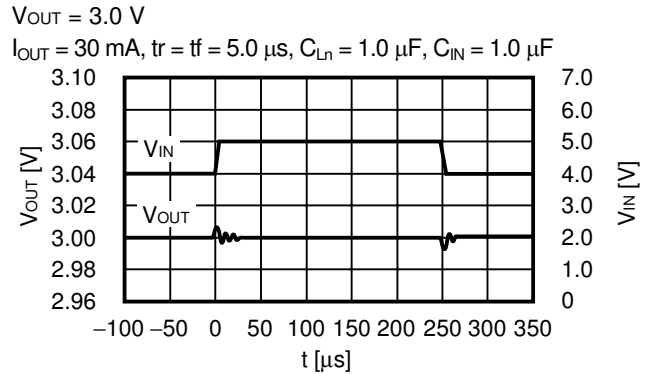
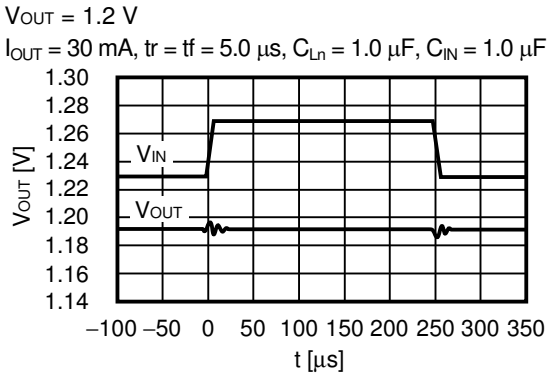

(2) Transient Response Characteristics of Load ($T_a = 25^\circ\text{C}$)

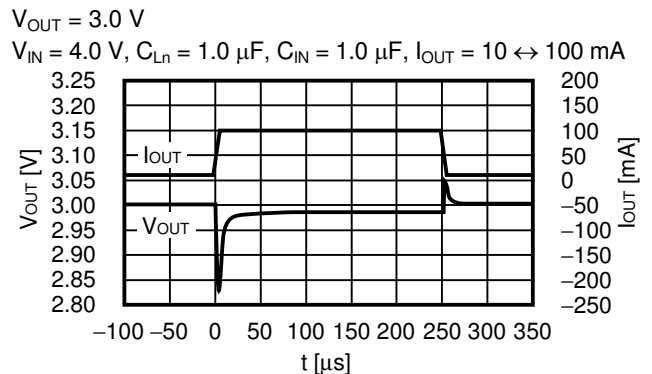
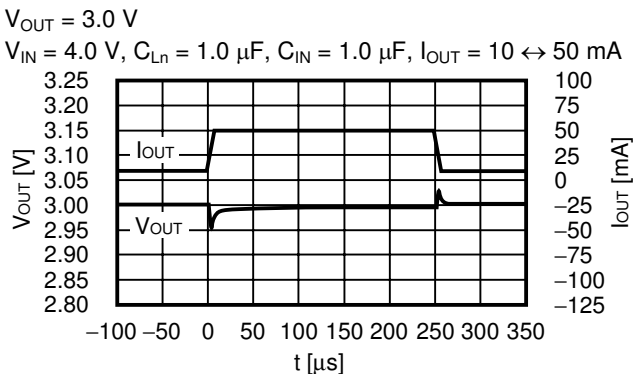
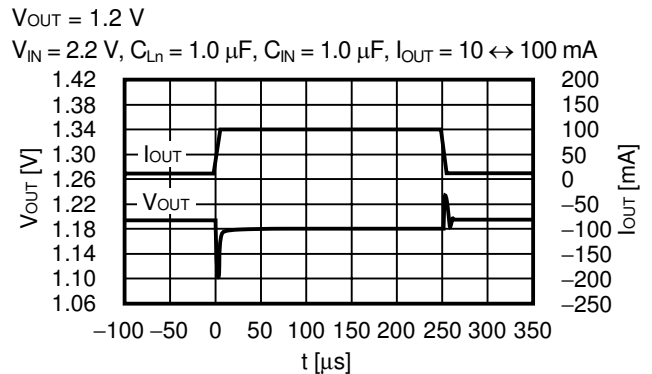
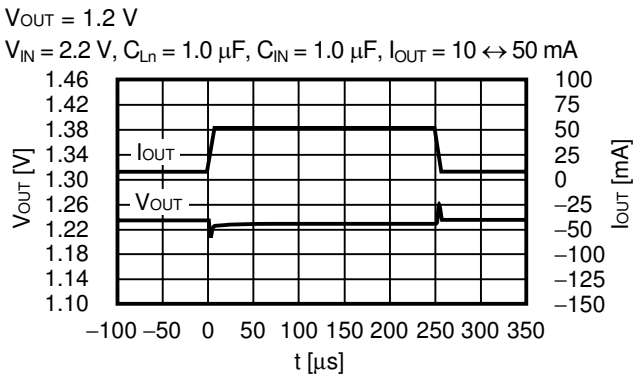

Remark C_{L1} : Capacitor set to V_{OUTn} pin externally ($n = 1, 2$)

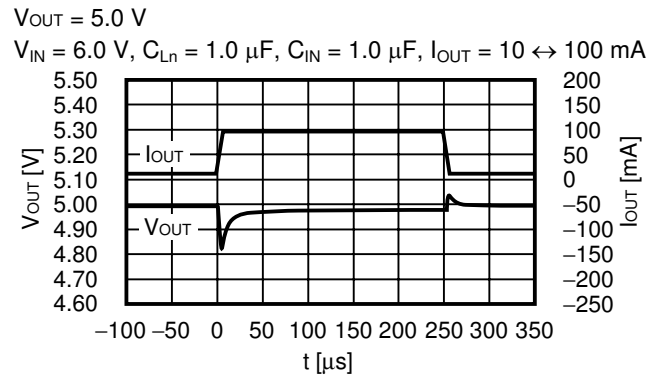
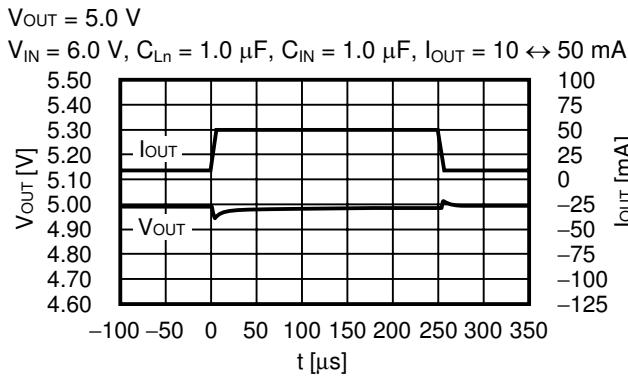

(3) Transient Response Characteristics of ON/OFF Pin ($T_a = 25^\circ\text{C}$)

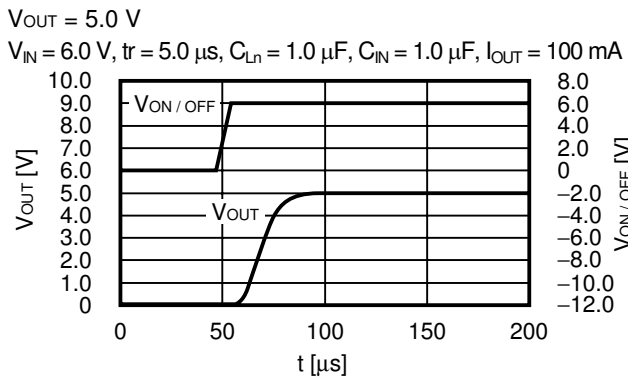
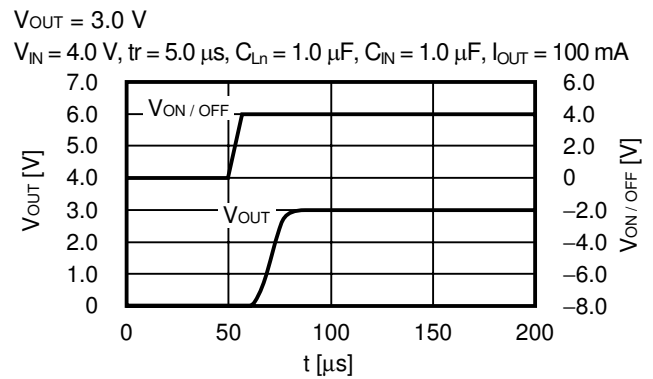
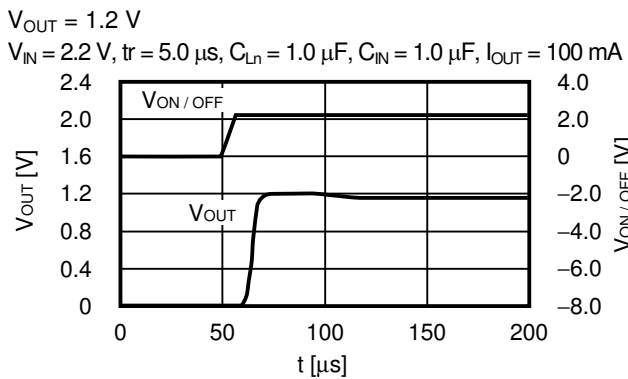

Remark C_{L_n} : Capacitor set to V_{OUTn} pin externally ($n = 1, 2$)

(4) Transient Response Characteristics of Load's Mutual Interference (Ta = 25°C)

$V_{OUT1} = V_{OUT2} = 1.2\text{ V}$

$V_{IN} = 2.2\text{ V}, C_{L1} = C_{L2} = 1.0\ \mu\text{F}, C_{IN} = 1.0\ \mu\text{F},$

$I_{OUT1} = 10 \leftrightarrow 100\text{ mA}, I_{OUT2} = \text{no load}$

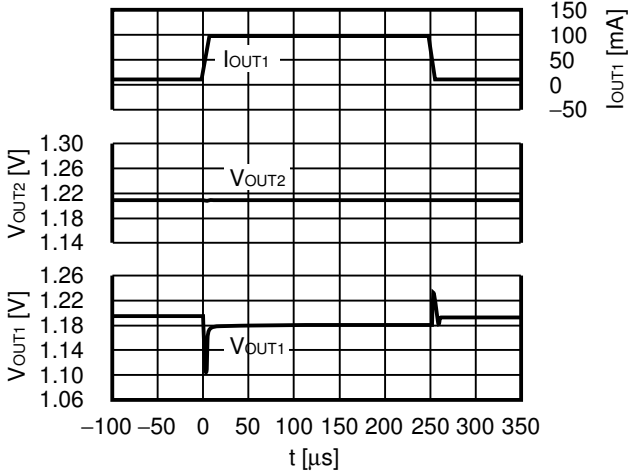

$V_{OUT1} = V_{OUT2} = 3.0\text{ V}$

$V_{IN} = 4.0\text{ V}, C_{L1} = C_{L2} = 1.0\ \mu\text{F}, C_{IN} = 1.0\ \mu\text{F},$

$I_{OUT1} = 10 \leftrightarrow 100\text{ mA}, I_{OUT2} = \text{no load}$

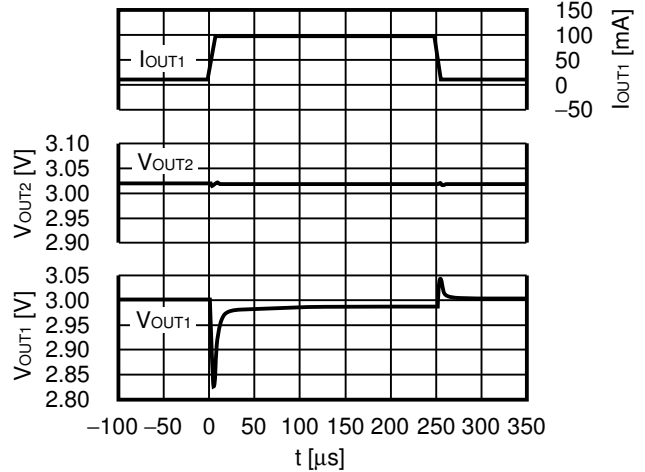

$V_{OUT1} = V_{OUT2} = 5.0\text{ V}$

$V_{IN} = 6.0\text{ V}, C_{L1} = C_{L2} = 1.0\ \mu\text{F}, C_{IN} = 1.0\ \mu\text{F},$

$I_{OUT1} = 10 \leftrightarrow 100\text{ mA}, I_{OUT2} = \text{no load}$

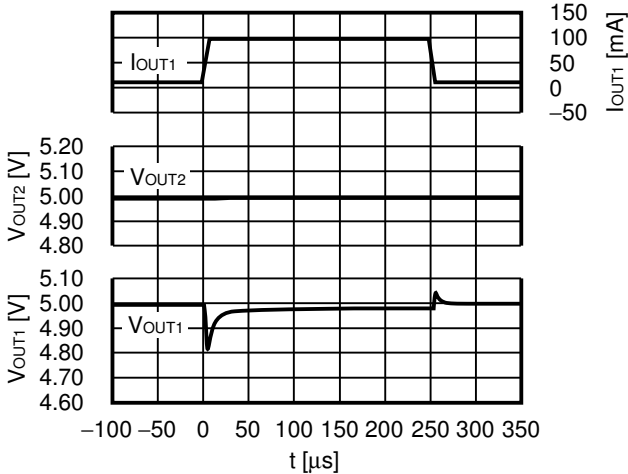

(5) Example of Equivalent Series Resistance vs. Output Current Characteristics (Ta = 25°C)

$C_{IN} = C_{Ln} = 1.0\ \mu\text{F}$

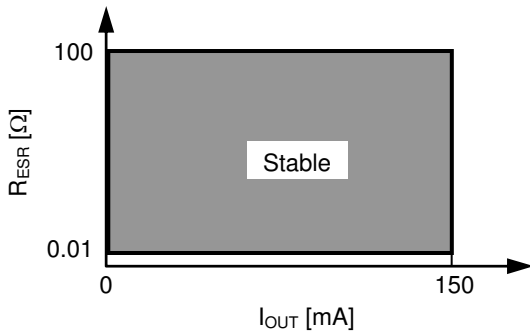

Remark C_{Ln} : Capacitor set to VOUTn pin externally (n = 1, 2)

■ Marking Specifications

(1) SNT-6A

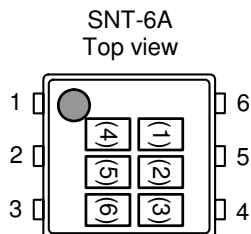

(1) to (3) : Product code (Refer to **Product name vs. Product code**)
(4) to (6) : Lot number

Product name vs. Product code

(a) S-1721 Series A type

| Product Name | Product code | | |
|-------------------|--------------|-----|-----|
| | (1) | (2) | (3) |
| S-1721A1212-I6T1x | S | 2 | B |
| S-1721A1215-I6T1x | S | 2 | D |
| S-1721A1218-I6T1x | S | 2 | S |
| S-1721A1225-I6T1x | S | 6 | D |
| S-1721A1226-I6T1x | S | 6 | 7 |
| S-1721A1228-I6T1x | S | 6 | E |
| S-1721A122J-I6T1x | S | 6 | F |
| S-1721A1230-I6T1x | S | 6 | G |
| S-1721A1233-I6T1x | S | 2 | N |
| S-1721A1C18-I6T1x | S | 2 | W |
| S-1721A1512-I6T1x | S | 6 | H |
| S-1721A1513-I6T1x | S | 2 | P |
| S-1721A1515-I6T1x | S | 2 | Q |
| S-1721A1518-I6T1x | S | 6 | I |
| S-1721A1525-I6T1x | S | 6 | J |
| S-1721A152J-I6T1x | S | 6 | K |
| S-1721A1530-I6T1x | S | 6 | L |
| S-1721A1533-I6T1x | S | 6 | M |
| S-1721A1812-I6T1x | S | 2 | T |
| S-1721A1815-I6T1x | S | 6 | N |
| S-1721A1818-I6T1x | S | 2 | X |
| S-1721A1825-I6T1x | S | 2 | F |
| S-1721A1826-I6T1x | S | 2 | 7 |
| S-1721A1828-I6T1x | S | 2 | G |
| S-1721A1829-I6T1x | S | 6 | 4 |
| S-1721A182J-I6T1x | S | 2 | U |
| S-1721A1830-I6T1x | S | 2 | 3 |
| S-1721A1833-I6T1x | S | 2 | 2 |
| S-1721A2020-I6T1x | S | 2 | C |
| S-1721A2121-I6T1x | S | 2 | R |
| S-1721A2512-I6T1x | S | 6 | O |

| Product Name | Product code | | |
|-------------------|--------------|-----|-----|
| | (1) | (2) | (3) |
| S-1721A2515-I6T1x | S | 6 | P |
| S-1721A2518-I6T1x | S | 2 | Z |
| S-1721A2525-I6T1x | S | 6 | Q |
| S-1721A2528-I6T1x | S | 6 | R |
| S-1721A252J-I6T1x | S | 6 | S |
| S-1721A2530-I6T1x | S | 6 | T |
| S-1721A2533-I6T1x | S | 6 | U |
| S-1721A2613-I6T1x | S | 6 | A |
| S-1721A2812-I6T1x | S | 6 | B |
| S-1721A2815-I6T1x | S | 2 | H |
| S-1721A2818-I6T1x | S | 2 | I |
| S-1721A2825-I6T1x | S | 6 | V |
| S-1721A2826-I6T1x | S | 2 | 8 |
| S-1721A2828-I6T1x | S | 2 | A |
| S-1721A282J-I6T1x | S | 6 | W |
| S-1721A2830-I6T1x | S | 6 | X |
| S-1721A2833-I6T1x | S | 6 | C |
| S-1721A2J12-I6T1x | S | 6 | 9 |
| S-1721A2J15-I6T1x | S | 7 | A |
| S-1721A2J18-I6T1x | S | 2 | V |
| S-1721A2J2J-I6T1x | S | 2 | J |
| S-1721A2J33-I6T1x | S | 6 | 8 |
| S-1721A3018-I6T1x | S | 2 | 6 |
| S-1721A3028-I6T1x | S | 6 | Y |
| S-1721A3030-I6T1x | S | 2 | K |
| S-1721A3033-I6T1x | S | 6 | Z |
| S-1721A3119-I6T1x | S | 2 | L |
| S-1721A3318-I6T1x | S | 2 | M |
| S-1721A3330-I6T1x | S | 6 | 2 |
| S-1721A3333-I6T1x | S | 2 | O |

Remark 1. Please contact our sales office for products with specifications other than the above.

2. x: G or U

3. Please select products of environmental code = U for Sn 100%, halogen-free products.

(b) S-1721 Series B type

| Product Name | Product code | | |
|-------------------|--------------|-----|-----|
| | (1) | (2) | (3) |
| S-1721B1515-I6T1x | S | 3 | A |
| S-1721B1518-I6T1x | S | 3 | B |
| S-1721B1812-I6T1x | S | 3 | C |
| S-1721B1818-I6T1x | S | 3 | D |
| S-1721B2818-I6T1x | S | 3 | E |
| S-1721B2J2J-I6T1x | S | 3 | F |

(c) S-1721 Series C type

| Product Name | Product code | | |
|-------------------|--------------|-----|-----|
| | (1) | (2) | (3) |
| S-1721C2J2J-I6T1x | S | 4 | A |

(d) S-1721 Series D type

| Product Name | Product code | | |
|-------------------|--------------|-----|-----|
| | (1) | (2) | (3) |
| S-1721D1818-I6T1x | S | 4 | T |
| S-1721D3318-I6T1x | S | 4 | S |

(e) S-1721 Series E type

| Product Name | Product code | | |
|-------------------|--------------|-----|-----|
| | (1) | (2) | (3) |
| S-1721E1328-I6T1x | S | 5 | A |
| S-1721E1528-I6T1x | S | 5 | B |
| S-1721E1828-I6T1x | S | 5 | D |
| S-1721E1833-I6T1x | S | 5 | L |
| S-1721E2518-I6T1x | S | 5 | E |
| S-1721E2525-I6T1x | S | 5 | F |
| S-1721E2530-I6T1x | S | 5 | O |
| S-1721E2818-I6T1x | S | 5 | G |
| S-1721E2833-I6T1x | S | 5 | H |
| S-1721E2J25-I6T1x | S | 5 | K |
| S-1721E2J2J-I6T1x | S | 5 | I |
| S-1721E3012-I6T1x | S | 5 | S |
| S-1721E3025-I6T1x | S | 5 | P |
| S-1721E3033-I6T1x | S | 5 | J |

Remark 1. Please contact our sales office for products with specifications other than the above.

2. x: G or U

3. Please select products of environmental code = U for Sn 100%, halogen-free products.

(2) SOT-23-6

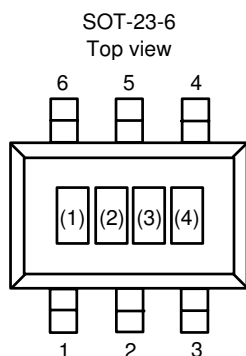

(1) to (3) : Product code (Refer to **Product name vs. Product code**)
(4) : Lot number

Product name vs. Product code

(a) S-1721 Series A type

| Product Name | Product code | | |
|-------------------|--------------|-----|-----|
| | (1) | (2) | (3) |
| S-1721A1212-M6T1x | S | 2 | B |
| S-1721A1215-M6T1x | S | 2 | D |
| S-1721A1228-M6T1x | S | 6 | E |
| S-1721A1233-M6T1x | S | 2 | N |
| S-1721A1328-M6T1x | S | 2 | 4 |
| S-1721A1330-M6T1x | S | 2 | E |
| S-1721A1528-M6T1x | S | 2 | Y |
| S-1721A1530-M6T1x | S | 6 | L |
| S-1721A1533-M6T1x | S | 6 | M |
| S-1721A1825-M6T1x | S | 2 | F |
| S-1721A1828-M6T1x | S | 2 | G |
| S-1721A1830-M6T1x | S | 2 | 3 |
| S-1721A1833-M6T1x | S | 2 | 2 |
| S-1721A2020-M6T1x | S | 2 | C |

| Product Name | Product code | | |
|-------------------|--------------|-----|-----|
| | (1) | (2) | (3) |
| S-1721A2518-M6T1x | S | 2 | Z |
| S-1721A2528-M6T1x | S | 6 | R |
| S-1721A2812-M6T1x | S | 6 | B |
| S-1721A2815-M6T1x | S | 2 | H |
| S-1721A2818-M6T1x | S | 2 | I |
| S-1721A2828-M6T1x | S | 2 | A |
| S-1721A2830-M6T1x | S | 6 | X |
| S-1721A2833-M6T1x | S | 6 | C |
| S-1721A2J2J-M6T1x | S | 2 | J |
| S-1721A3312-M6T1x | S | 2 | 9 |
| S-1721A3318-M6T1x | S | 2 | M |
| S-1721A3328-M6T1x | S | 6 | 3 |
| S-1721A3333-M6T1x | S | 2 | O |

(b) S-1721 Series B type

| Product Name | Product code | | |
|-------------------|--------------|-----|-----|
| | (1) | (2) | (3) |
| S-1721B2828-M6T1x | S | 3 | G |

(c) S-1721 Series C type

| Product Name | Product code | | |
|-------------------|--------------|-----|-----|
| | (1) | (2) | (3) |
| S-1721C2J2J-M6T1x | S | 4 | A |

(d) S-1721 Series D type

| Product Name | Product code | | |
|-------------------|--------------|-----|-----|
| | (1) | (2) | (3) |
| S-1721D1828-M6T1x | S | 4 | R |
| S-1721D3318-M6T1x | S | 4 | S |

(e) S-1721 Series E type

| Product Name | Product code | | |
|-------------------|--------------|-----|-----|
| | (1) | (2) | (3) |
| S-1721E1528-M6T1x | S | 5 | B |
| S-1721E1825-M6T1x | S | 5 | U |
| S-1721E1826-M6T1x | S | 5 | C |
| S-1721E1828-M6T1x | S | 5 | D |
| S-1721E1830-M6T1x | S | 5 | Q |
| S-1721E1833-M6T1x | S | 5 | L |
| S-1721E2025-M6T1x | S | 5 | T |
| S-1721E2813-M6T1x | S | 5 | M |
| S-1721E2818-M6T1x | S | 5 | G |
| S-1721E2833-M6T1x | S | 5 | H |
| S-1721E2J25-M6T1x | S | 5 | K |
| S-1721E3312-M6T1x | S | 5 | N |

- Remark 1.** Please contact our sales office for products with specifications other than the above.
2. x: G or U
3. Please select products of environmental code = U for Sn 100%, halogen-free products.

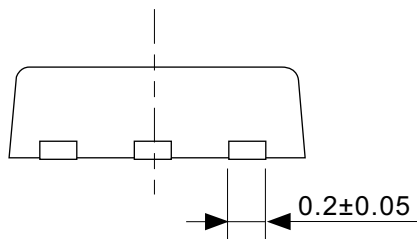
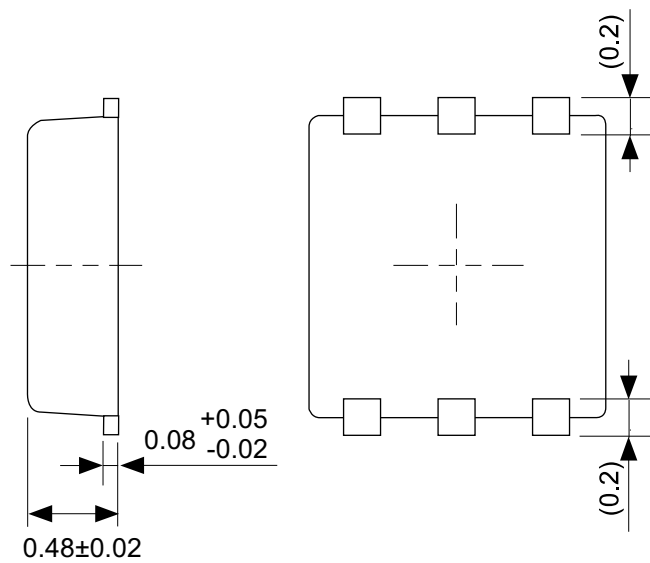
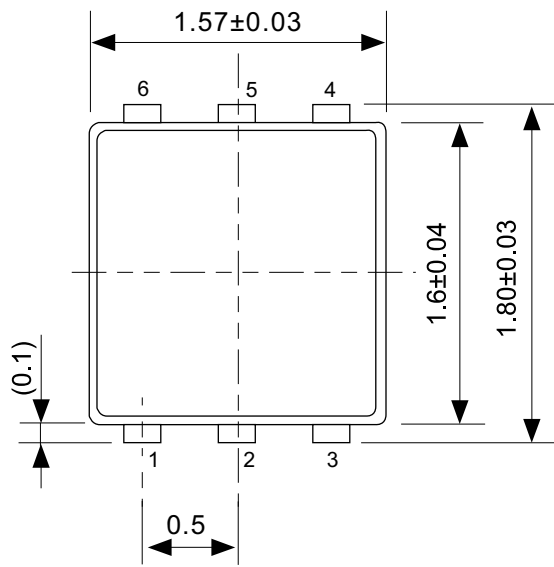

No. PG006-A-P-SD-2.0

| | |
|------------------------|-------------------------|
| TITLE | SNT-6A-A-PKG Dimensions |
| No. | PG006-A-P-SD-2.0 |
| SCALE | |
| UNIT | mm |
| Seiko Instruments Inc. | |

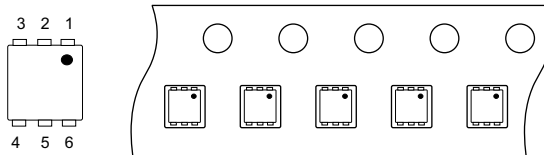
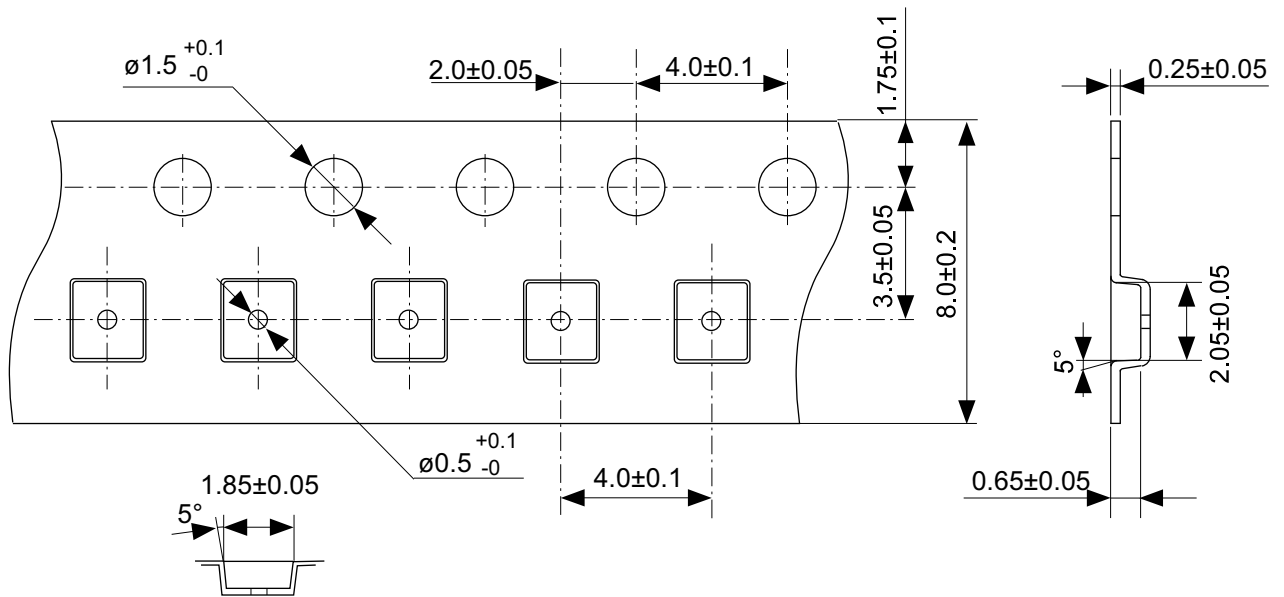

Feed direction →

No. PG006-A-C-SD-1.0

| | |
|------------------------|-----------------------|
| TITLE | SNT-6A-A-Carrier Tape |
| No. | PG006-A-C-SD-1.0 |
| SCALE | |
| UNIT | mm |
| Seiko Instruments Inc. | |

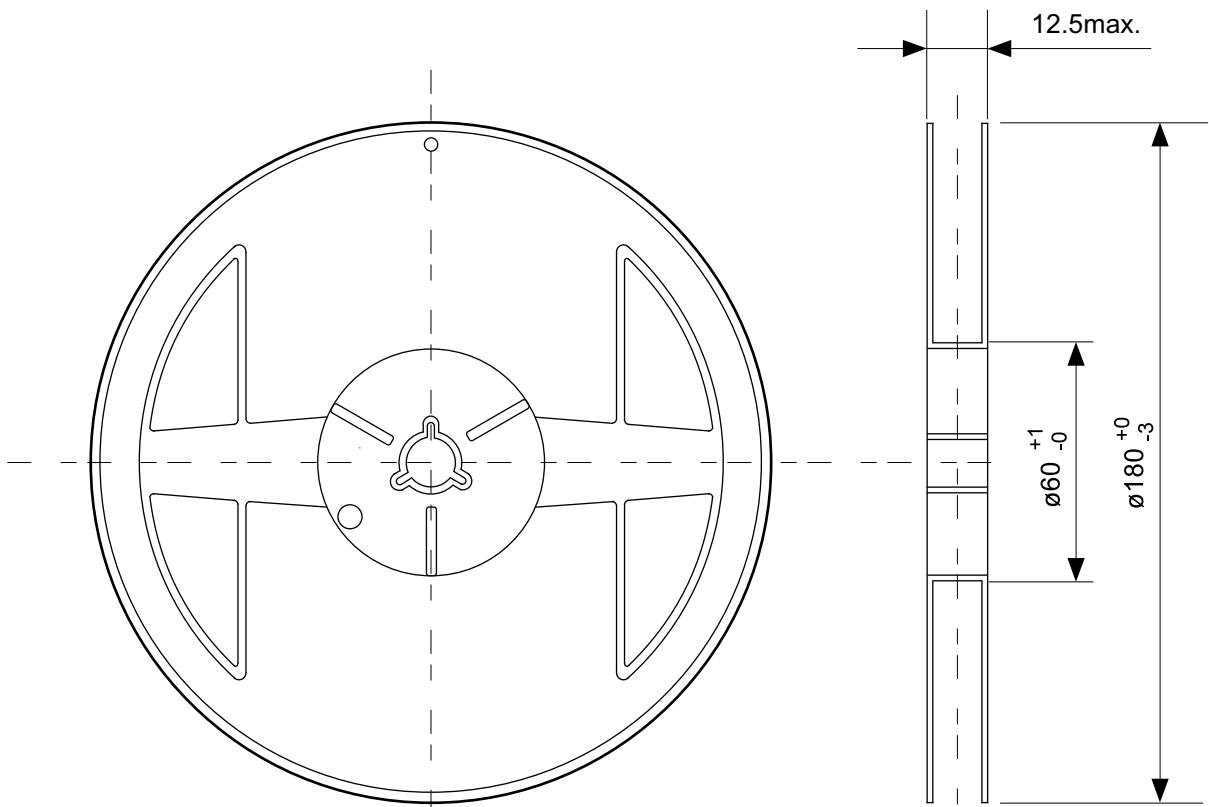

Enlarged drawing in the central part

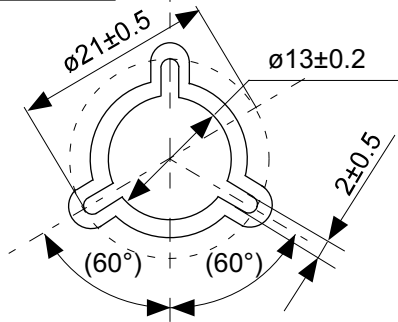

No. PG006-A-R-SD-1.0

| | | | |
|------------------------|------------------|------|-------|
| TITLE | SNT-6A-A-Reel | | |
| No. | PG006-A-R-SD-1.0 | | |
| SCALE | | QTY. | 5,000 |
| UNIT | mm | | |
| | | | |
| Seiko Instruments Inc. | | | |

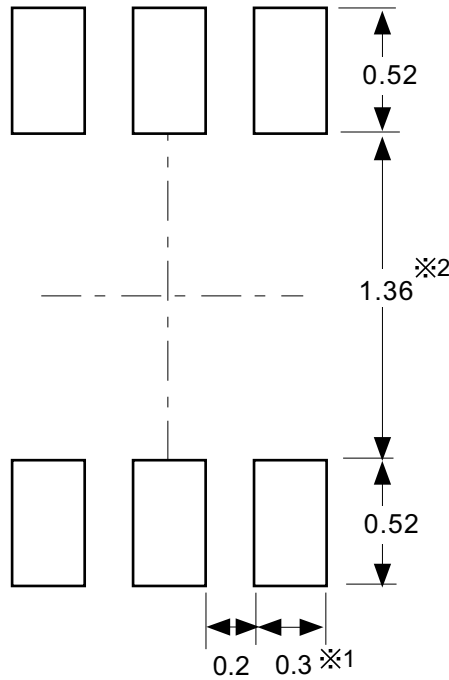

※1. ランドパターンの幅に注意してください (0.25 mm min. / 0.30 mm typ.).
 ※2. パッケージ中央にランドパターンを広げないでください (1.30 mm ~ 1.40 mm)。

- 注意
1. パッケージのモールド樹脂下にシルク印刷やハンダ印刷などしないでください。
 2. パッケージ下の配線上のソルダーレジストなどの厚みをランドパターン表面から0.03 mm以下にしてください。
 3. マスク開口サイズと開口位置はランドパターンと合わせてください。
 4. 詳細は“SNTパッケージ活用の手引き”を参照してください。

※1. Pay attention to the land pattern width (0.25 mm min. / 0.30 mm typ.).
 ※2. Do not widen the land pattern to the center of the package (1.30 mm ~ 1.40 mm).

- Caution**
1. Do not do silkscreen printing and solder printing under the mold resin of the package.
 2. The thickness of the solder resist on the wire pattern under the package should be 0.03 mm or less from the land pattern surface.
 3. Match the mask aperture size and aperture position with the land pattern.
 4. Refer to "SNT Package User's Guide" for details.

※1. 请注意焊盘模式的宽度 (0.25 mm min. / 0.30 mm typ.).
 ※2. 请勿向封装中间扩展焊盘模式 (1.30 mm ~ 1.40 mm)。

- 注意
1. 请勿在树脂型封装的下面印刷丝网、焊锡。
 2. 在封装下、布线上的阻焊膜厚度 (从焊盘模式表面起) 请控制在0.03 mm以下。
 3. 掩膜的开口尺寸和开口位置请与焊盘模式对齐。
 4. 详细内容请参阅 "SNT封装的应用指南"。

No. PG006-A-L-SD-4.0

| | |
|------------------------|------------------------------|
| TITLE | SNT-6A-A-Land Recommendation |
| No. | PG006-A-L-SD-4.0 |
| SCALE | |
| UNIT | mm |
| | |
| Seiko Instruments Inc. | |

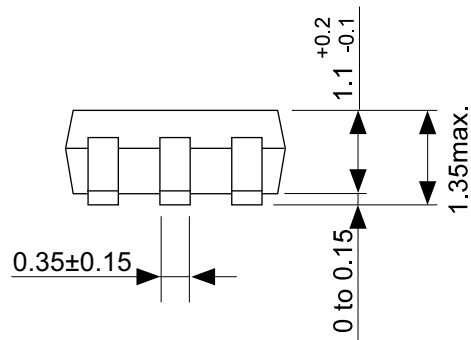
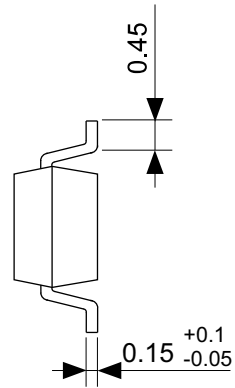
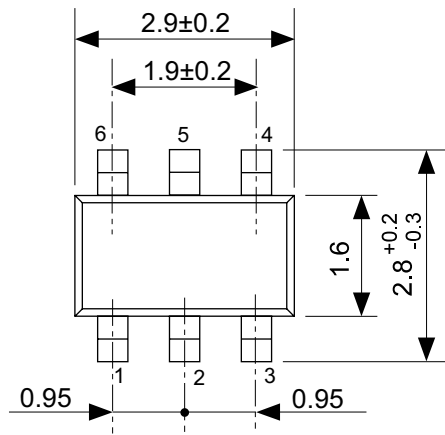

No. MP006-A-P-SD-2.0

| | |
|------------------------|-------------------------|
| TITLE | SOT236-A-PKG Dimensions |
| No. | MP006-A-P-SD-2.0 |
| SCALE | |
| UNIT | mm |
| | |
| Seiko Instruments Inc. | |

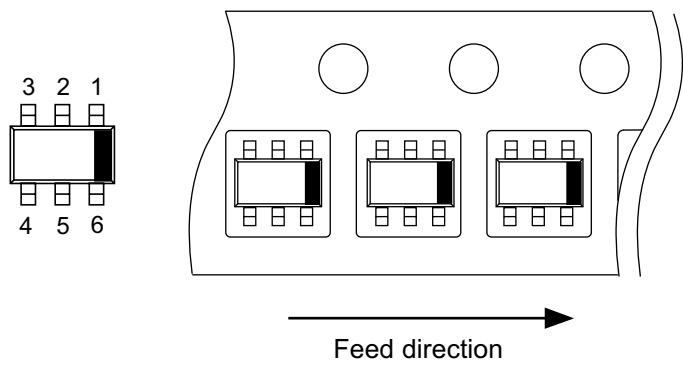
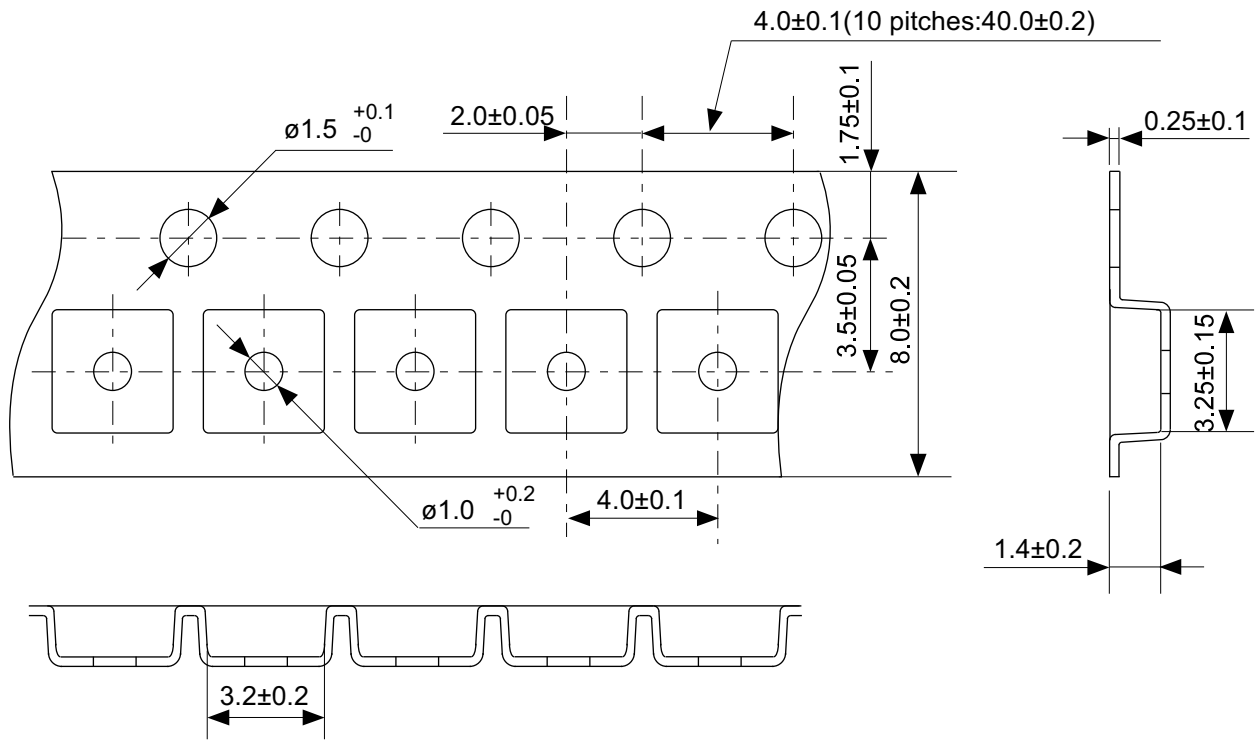

No. MP006-A-C-SD-3.1

| | |
|------------------------|-----------------------|
| TITLE | SOT236-A-Carrier Tape |
| No. | MP006-A-C-SD-3.1 |
| SCALE | |
| UNIT | mm |
| | |
| Seiko Instruments Inc. | |

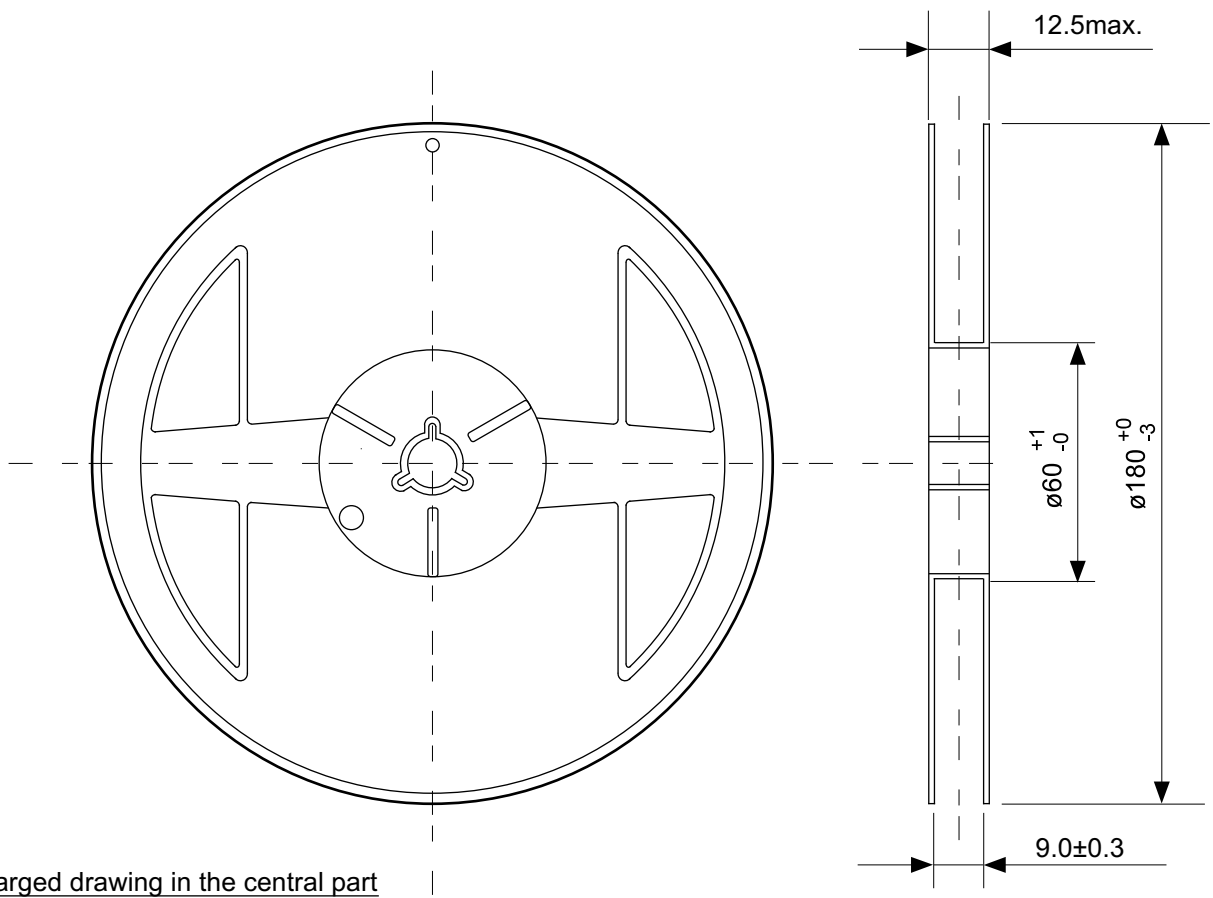

Enlarged drawing in the central part

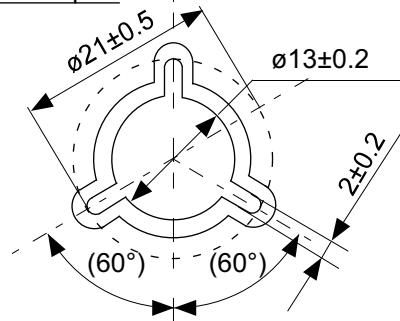

No. MP006-A-R-SD-2.1

| | | | |
|------------------------|------------------|-----|-------|
| TITLE | SOT236-A-Reel | | |
| No. | MP006-A-R-SD-2.1 | | |
| SCALE | | QTY | 3,000 |
| UNIT | mm | | |
| | | | |
| Seiko Instruments Inc. | | | |



Seiko Instruments Inc.
www.sii-ic.com

- The information described herein is subject to change without notice.
- Seiko Instruments Inc. is not responsible for any problems caused by circuits or diagrams described herein whose related industrial properties, patents, or other rights belong to third parties. The application circuit examples explain typical applications of the products, and do not guarantee the success of any specific mass-production design.
- When the products described herein are regulated products subject to the Wassenaar Arrangement or other agreements, they may not be exported without authorization from the appropriate governmental authority.
- Use of the information described herein for other purposes and/or reproduction or copying without the express permission of Seiko Instruments Inc. is strictly prohibited.
- The products described herein cannot be used as part of any device or equipment affecting the human body, such as exercise equipment, medical equipment, security systems, gas equipment, vehicle equipment, in-vehicle equipment, aviation equipment, aerospace equipment, and nuclear-related equipment, without prior written permission of Seiko Instruments Inc.
- The products described herein are not designed to be radiation-proof.
- Although Seiko Instruments Inc. exerts the greatest possible effort to ensure high quality and reliability, the failure or malfunction of semiconductor products may occur. The user of these products should therefore give thorough consideration to safety design, including redundancy, fire-prevention measures, and malfunction prevention, to prevent any accidents, fires, or community damage that may ensue.