

SUPER-SMALL PACKAGE 2-CIRCUIT BUILT-IN DELAY FUNCTION HIGH RIPPLE-REJECTION LOW DROPOUT CMOS VOLTAGE REGULATOR

The S-13D1 Series, developed by using the CMOS technology, is a 2-channel positive voltage regulator IC which has low dropout voltage, high accuracy output voltage and low current consumption.

A 0.22 μF small ceramic capacitor can be used, and the S-13D1 Series includes a load current protection circuit that prevents the output current from exceeding the current capacitance of the output transistor and a thermal shutdown circuit that prevents damage due to overheating. Also, C / F type in the S-13D1 Series has a built-in delay function that sets the difference of rising time between channels.

■ Features

- Output voltage: 1.0 V to 3.6 V, selectable in 0.05 V step
- Input voltage: 1.5 V to 5.5 V
- Output voltage accuracy: $\pm 1.0\%$ (1.0 V to 1.45 V output product : ± 15 mV)
- Dropout voltage: 80 mV typ. (2.8 V output product, $I_{\text{OUT}} = 100$ mA)
- Current consumption:
 - During operation: 39 μA typ., 58 μA max. (per circuit)
 - During power-off: 0.1 μA typ., 1.0 μA max.
- Output current: Possible to output 150 mA ($V_{\text{IN}} \geq V_{\text{OUT(S)}} + 1.0$ V)^{*1} (per circuit)
- Input and output capacitors: A ceramic capacitor of 0.22 μF or more can be used.
- Ripple rejection: 70 dB typ. (3.6 V output product, $f = 1.0$ kHz)
- Built-in overcurrent protection circuit: Limits overcurrent of output transistor.
- Built-in thermal shutdown circuit: Prevents damage caused by heat.
- Built-in ON / OFF circuit: Ensures long battery life.
- Constant current source pull-down is selectable.
- Discharge shunt function is selectable.
- Delay function is selectable.
- Operation temperature range: $T_a = -40^\circ\text{C}$ to $+85^\circ\text{C}$
- Lead-free (Sn 100%), halogen-free

*1. Attention should be paid to the power dissipation of the package when the output current is large.

■ Applications

- Constant-voltage power supply for digital camera
- Constant-voltage power supply for mobile phone
- Constant-voltage power supply for portable equipment

■ Packages

- SOT-23-6
- HSNT-6 (1212)

■ **Block Diagrams**

1. **S-13D1 Series A type**

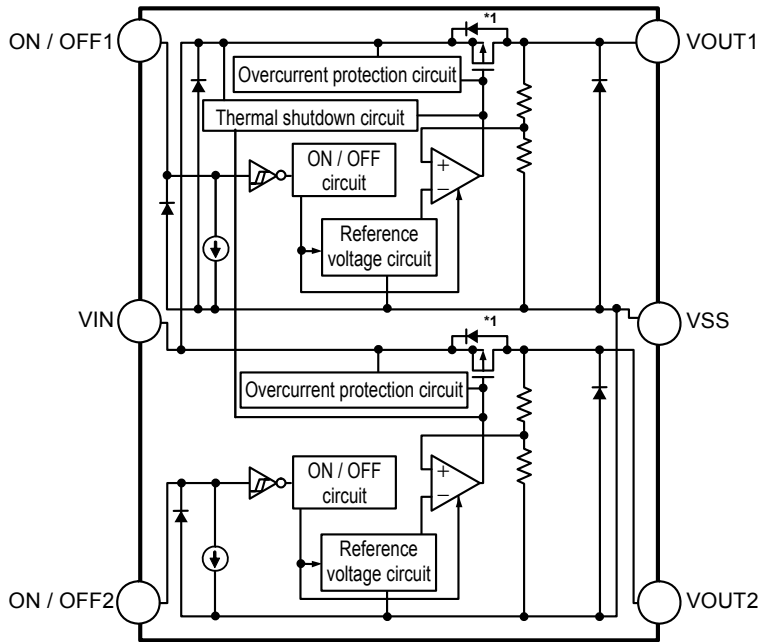

Function	Status
ON / OFF logic	Active "H"
Discharge shunt function	Unavailable
Constant current source pull-down	Available
Delay function	Unavailable

*1. Parasitic diode

Figure 1

2. **S-13D1 Series B type**

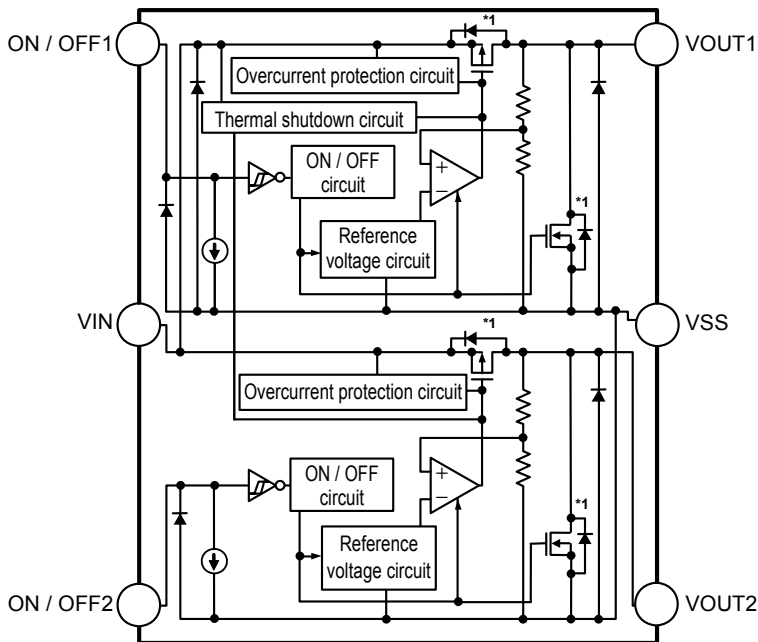

Function	Status
ON / OFF logic	Active "H"
Discharge shunt function	Available
Constant current source pull-down	Available
Delay function	Unavailable

*1. Parasitic diode

Figure 2

3. S-13D1 Series C type

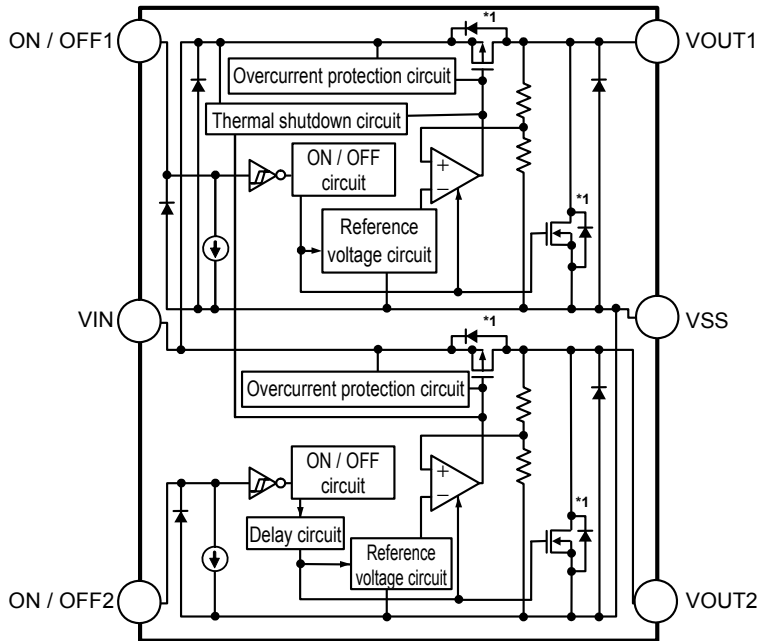

Function	Status
ON / OFF logic	Active "H"
Discharge shunt function	Available
Constant current source pull-down	Available
Delay function	Available

*1. Parasitic diode

Figure 3

4. S-13D1 Series D type

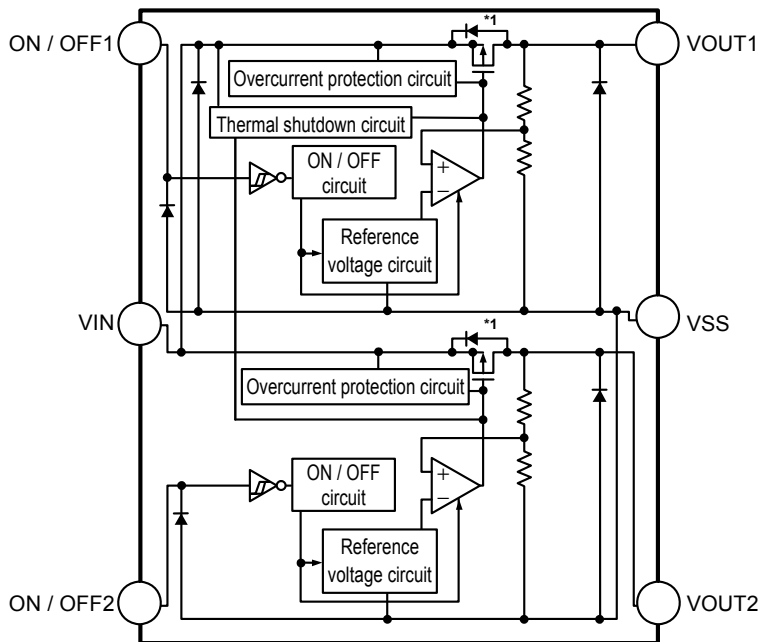

Function	Status
ON / OFF logic	Active "H"
Discharge shunt function	Unavailable
Constant current source pull-down	Unavailable
Delay function	Unavailable

*1. Parasitic diode

Figure 4

5. S-13D1 Series E type

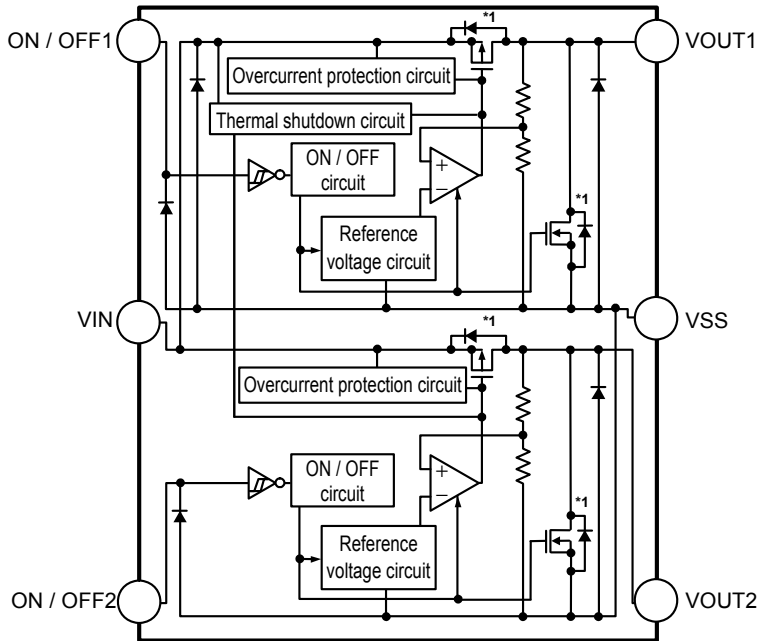

Function	Status
ON / OFF logic	Active "H"
Discharge shunt function	Available
Constant current source pull-down	Unavailable
Delay function	Unavailable

*1. Parasitic diode

Figure 5

6. S-13D1 Series F type

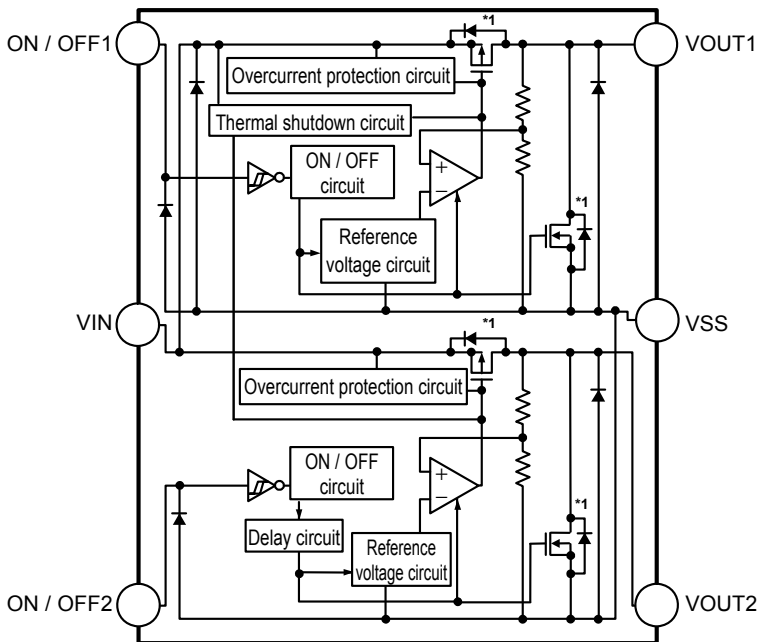

Function	Status
ON / OFF logic	Active "H"
Discharge shunt function	Available
Constant current source pull-down	Unavailable
Delay function	Available

*1. Parasitic diode

Figure 6

■ Product Name Structure

Users can select the product type, output voltage, and package type for the S-13D1 Series. Refer to "1. Product name" regarding the contents of product name, "2. Function list of product types" regarding the product type, "3. Packages" regarding the package drawings, "4. Product name list" regarding details of the product name.

1. Product name

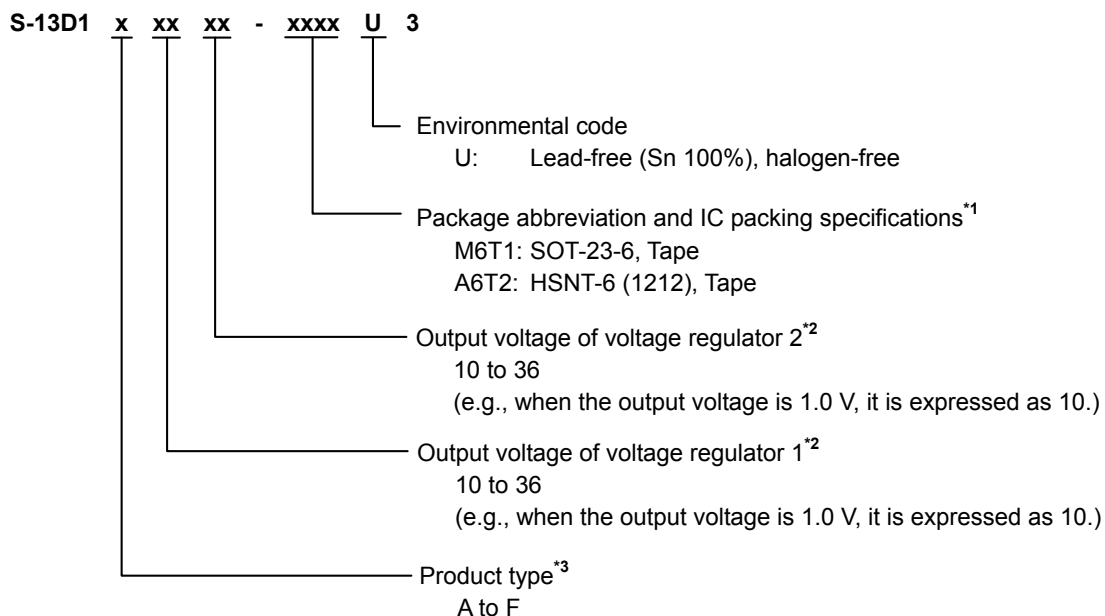

*1. Refer to the tape drawing.

*2. If you request the product which has 0.05 V step, contact our sales office.

*3. Refer to "2. Function list of product types".

2. Function list of product types

Table 1

Product Type	ON / OFF Logic	Discharge Shunt Function	Constant Current Source Pull-down	Delay Function
A	Active "H"	Unavailable	Available	Unavailable
B	Active "H"	Available	Available	Unavailable
C	Active "H"	Available	Available	Available
D	Active "H"	Unavailable	Unavailable	Unavailable
E	Active "H"	Available	Unavailable	Unavailable
F	Active "H"	Available	Unavailable	Available

3. Packages

Table 2 Package Drawing Codes

Package Name	Dimension	Tape	Reel	Land
SOT-23-6	MP006-A-P-SD	MP006-A-C-SD	MP006-A-R-SD	—
HSNT-6 (1212)	PM006-A-P-SD	PM006-A-C-SD	PM006-A-R-SD	PM006-A-L-SD

4. Product name list

4.1 S-13D1 Series B type

ON / OFF logic: Active "H" Discharge shunt function: Available
 Constant current source pull-down: Available Delay function: Unavailable

Table 3

Voltage Regulator 1 Output Voltage	Voltage Regulator 2 Output Voltage	SOT-23-6	HSNT-6 (1212)
1.2 V ± 15 mV	1.8 V ± 1.0%	S-13D1B1218-M6T1U3	S-13D1B1218-A6T2U3
1.5 V ± 1.0%	2.8 V ± 1.0%	S-13D1B1528-M6T1U3	S-13D1B1528-A6T2U3
1.8 V ± 1.0%	1.2 V ± 15 mV	S-13D1B1812-M6T1U3	S-13D1B1812-A6T2U3
1.8 V ± 1.0%	1.5 V ± 1.0%	S-13D1B1815-M6T1U3	S-13D1B1815-A6T2U3
1.8 V ± 1.0%	1.8 V ± 1.0%	S-13D1B1818-M6T1U3	S-13D1B1818-A6T2U3
1.8 V ± 1.0%	2.8 V ± 1.0%	S-13D1B1828-M6T1U3	S-13D1B1828-A6T2U3
1.8 V ± 1.0%	3.3 V ± 1.0%	S-13D1B1833-M6T1U3	S-13D1B1833-A6T2U3
2.5 V ± 1.0%	1.8 V ± 1.0%	S-13D1B2518-M6T1U3	S-13D1B2518-A6T2U3
2.8 V ± 1.0%	1.8 V ± 1.0%	S-13D1B2818-M6T1U3	S-13D1B2818-A6T2U3
2.8 V ± 1.0%	2.8 V ± 1.0%	S-13D1B2828-M6T1U3	S-13D1B2828-A6T2U3
2.8 V ± 1.0%	3.3 V ± 1.0%	S-13D1B2833-M6T1U3	S-13D1B2833-A6T2U3
2.85 V ± 1.0%	2.85 V ± 1.0%	S-13D1B2J2J-M6T1U3	S-13D1B2J2J-A6T2U3
3.0 V ± 1.0%	1.8 V ± 1.0%	S-13D1B3018-M6T1U3	S-13D1B3018-A6T2U3
3.1 V ± 1.0%	3.0 V ± 1.0%	S-13D1B3130-M6T1U3	S-13D1B3130-A6T2U3
3.3 V ± 1.0%	3.0 V ± 1.0%	S-13D1B3330-M6T1U3	S-13D1B3330-A6T2U3
3.3 V ± 1.0%	3.3 V ± 1.0%	S-13D1B3333-M6T1U3	S-13D1B3333-A6T2U3

Remark Please contact our sales office for products with specifications other than the above.

4.2 S-13D1 Series C type

ON / OFF logic: Active "H" Discharge shunt function: Available
 Constant current source pull-down: Available Delay function: Available

Table 4

Voltage Regulator 1 Output Voltage	Voltage Regulator 2 Output Voltage	SOT-23-6	HSNT-6 (1212)
1.2 V ± 15 mV	1.8 V ± 1.0%	S-13D1C1218-M6T1U3	S-13D1C1218-A6T2U3
1.5 V ± 1.0%	2.8 V ± 1.0%	S-13D1C1528-M6T1U3	S-13D1C1528-A6T2U3
1.8 V ± 1.0%	1.8 V ± 1.0%	S-13D1C1818-M6T1U3	S-13D1C1818-A6T2U3
1.8 V ± 1.0%	2.8 V ± 1.0%	S-13D1C1828-M6T1U3	S-13D1C1828-A6T2U3
1.8 V ± 1.0%	3.3 V ± 1.0%	S-13D1C1833-M6T1U3	S-13D1C1833-A6T2U3
2.8 V ± 1.0%	2.8 V ± 1.0%	S-13D1C2828-M6T1U3	S-13D1C2828-A6T2U3
2.8 V ± 1.0%	3.3 V ± 1.0%	S-13D1C2833-M6T1U3	S-13D1C2833-A6T2U3
2.85 V ± 1.0%	2.85 V ± 1.0%	S-13D1C2J2J-M6T1U3	S-13D1C2J2J-A6T2U3
3.6 V ± 1.0%	3.6 V ± 1.0%	S-13D1C3636-M6T1U3	S-13D1C3636-A6T2U3

Remark Please contact our sales office for products with specifications other than the above.

4.3 S-13D1 Series D type

ON / OFF logic: Active "H" Discharge shunt function: Unavailable
 Constant current source pull-down: Unavailable Delay function: Unavailable

Table 5

Voltage Regulator 1 Output Voltage	Voltage Regulator 2 Output Voltage	SOT-23-6	HSNT-6 (1212)
1.2 V ± 15 mV	1.8 V ± 1.0%	S-13D1D1218-M6T1U3	S-13D1D1218-A6T2U3
1.5 V ± 1.0%	2.8 V ± 1.0%	S-13D1D1528-M6T1U3	S-13D1D1528-A6T2U3
1.8 V ± 1.0%	1.8 V ± 1.0%	S-13D1D1818-M6T1U3	S-13D1D1818-A6T2U3
1.8 V ± 1.0%	2.8 V ± 1.0%	S-13D1D1828-M6T1U3	S-13D1D1828-A6T2U3
1.8 V ± 1.0%	3.3 V ± 1.0%	S-13D1D1833-M6T1U3	S-13D1D1833-A6T2U3
2.8 V ± 1.0%	2.8 V ± 1.0%	S-13D1D2828-M6T1U3	S-13D1D2828-A6T2U3
2.8 V ± 1.0%	3.3 V ± 1.0%	S-13D1D2833-M6T1U3	S-13D1D2833-A6T2U3
2.85 V ± 1.0%	2.85 V ± 1.0%	S-13D1D2J2J-M6T1U3	S-13D1D2J2J-A6T2U3

Remark Please contact our sales office for products with specifications other than the above.

■ Pin Configurations

1. SOT-23-6

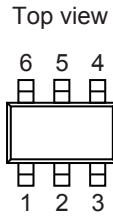

Figure 7

Table 6

Pin No.	Symbol	Description
1	ON / OFF1	ON / OFF 1 pin
2	VIN	Input voltage pin
3	ON / OFF2	ON / OFF 2 pin
4	VOUT2	Output voltage 2 pin
5	VSS	GND pin
6	VOUT1	Output voltage 1 pin

2. HSNT-6 (1212)

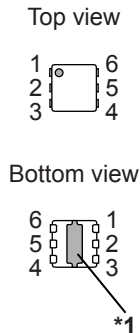

Figure 8

Table 7

Pin No.	Symbol	Description
1	VOUT1	Output voltage 1 pin
2	VOUT2	Output voltage 2 pin
3	VSS	GND pin
4	ON / OFF2	ON / OFF 2 pin
5	VIN	Input voltage pin
6	ON / OFF1	ON / OFF 1 pin

*1. Connect the heatsink of backside at shadowed area to the board, and set electric potential open or GND. However, do not use it as the function of electrode.

■ Absolute Maximum Ratings

Table 8

(Ta = +25°C unless otherwise specified)

Item	Symbol	Absolute Maximum Rating	Unit
Input voltage	V_{IN}	$V_{SS} - 0.3$ to $V_{SS} + 6.0$	V
	$V_{ON/OFF1}, V_{ON/OFF2}$	$V_{SS} - 0.3$ to $V_{SS} + 6.0$	V
Output voltage	V_{OUT1}, V_{OUT2}	$V_{SS} - 0.3$ to $V_{IN} + 0.3$	V
Output current	I_{OUT1}, I_{OUT2}	200	mA
Power dissipation	P_D	650 ^{*1}	mW
		480 ^{*1}	mW
Operation ambient temperature	T_{opr}	-40 to +85	°C
Storage temperature	T_{stg}	-40 to +125	°C

*1. When mounted on board

[Mounted board]

(1) Board size: 114.3 mm × 76.2 mm × t1.6 mm

(2) Name: JEDEC STANDARD51-7

Caution The absolute maximum ratings are rated values exceeding which the product could suffer physical damage. These values must therefore not be exceeded under any conditions.

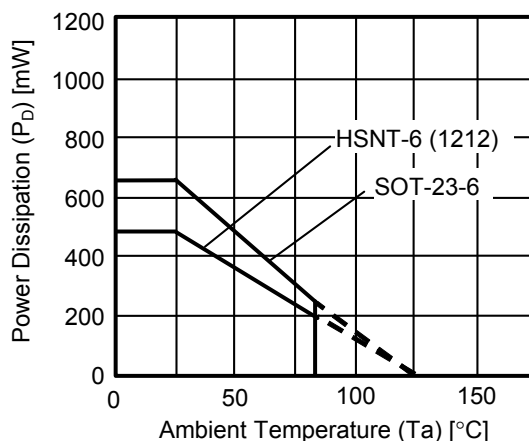

Figure 9 Power Dissipation of Package (When Mounted on Board)

Power Dissipation of HSNT-6 (1212) (Reference)

Power dissipation of package differs depending on the mounting conditions.
 Consider the power dissipation characteristics under the following conditions as reference.

[Mounted board]

- (1) Board size: 40 mm × 40 mm × t0.8 mm
- (2) Board material: Glass epoxy resin (four layers)
- (3) Wiring ratio: 50%
- (4) Test conditions: When mounted on board (wind speed: 0 m/s)
- (5) Land pattern: Refer to the recommended land pattern (drawing code: PM006-A-L-SD)

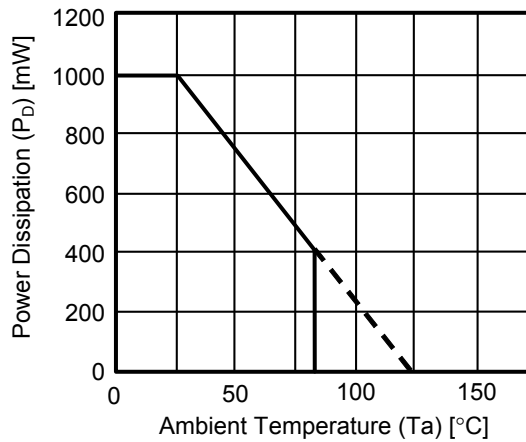

Figure 10 Power Dissipation of Package (When Mounted on Board)

Table 9

Condition	Power Dissipation (Reference)	Thermal Resistance Value (θ_{j-a})
HSNT-6 (1212) (When mounted on board)	1000 mW	100°C/W

■ Electrical Characteristics (per Circuit)

Table 10 (1 / 2)

(Ta = +25°C unless otherwise specified)

Item	Symbol	Condition	Min.	Typ.	Max.	Unit	Test Circuit	
Output voltage*1	V _{OUT(E)}	V _{IN} = V _{OUT(S)} + 1.0 V, I _{OUT} = 30 mA	1.0 V ≤ V _{OUT(S)} < 1.5 V	V _{OUT(S)} − 0.015	V _{OUT(S)}	V _{OUT(S)} + 0.015	V	1, 2
			1.5 V ≤ V _{OUT(S)} ≤ 3.6 V	V _{OUT(S)} × 0.99	V _{OUT(S)}	V _{OUT(S)} × 1.01	V	1, 2
Output current*2	I _{OUT}	V _{IN} ≥ V _{OUT(S)} + 1.0 V	150 ^{−5}	–	–	mA	4, 5	
Dropout voltage*3	V _{drop}	I _{OUT} = 100 mA	1.0 V ≤ V _{OUT(S)} < 1.1 V	0.5	0.52	0.54	V	1, 2
			1.1 V ≤ V _{OUT(S)} < 1.2 V	–	0.42	0.44	V	1, 2
			1.2 V ≤ V _{OUT(S)} < 1.3 V	–	0.32	0.34	V	1, 2
			1.3 V ≤ V _{OUT(S)} < 1.4 V	–	0.22	0.24	V	1, 2
			1.4 V ≤ V _{OUT(S)} < 1.5 V	–	0.15	0.22	V	1, 2
			1.5 V ≤ V _{OUT(S)} < 1.7 V	–	0.14	0.21	V	1, 2
			1.7 V ≤ V _{OUT(S)} < 2.1 V	–	0.12	0.19	V	1, 2
			2.1 V ≤ V _{OUT(S)} < 2.5 V	–	0.10	0.16	V	1, 2
			2.5 V ≤ V _{OUT(S)} < 2.8 V	–	0.09	0.14	V	1, 2
2.8 V ≤ V _{OUT(S)} ≤ 3.6 V	–	0.08	0.13	V	1, 2			
Line regulation	$\frac{\Delta V_{OUT1}}{\Delta V_{IN} \cdot V_{OUT}}$	V _{OUT(S)} + 0.5 V ≤ V _{IN} ≤ 5.5 V, I _{OUT} = 30 mA	–	0.02	0.2	%/V	1, 2	
Load regulation	ΔV _{OUT2}	V _{IN} = V _{OUT(S)} + 1.0 V, 1 mA ≤ I _{OUT} ≤ 150 mA	–	15	40	mV	1, 2	
Output voltage temperature coefficient*4	$\frac{\Delta V_{OUT}}{\Delta Ta \cdot V_{OUT}}$	V _{IN} = V _{OUT(S)} + 1.0 V, I _{OUT} = 30 mA, −40°C ≤ Ta ≤ +85°C	–	±100	–	ppm/°C	1, 2	
Current consumption during operation (2 circuits)	I _{SS}	V _{IN} = 5.5 V, ON / OFF pin = ON, no load	–	78	116	μA	3	
Current consumption during operation (per circuit)	I _{SS1}	V _{IN} = V _{OUT(S)} + 1.0 V, ON / OFF pin = ON, no load	–	39	58	μA	3	
Current consumption during power-off	I _{SS2}	V _{IN} = V _{OUT(S)} + 1.0 V, ON / OFF pin = OFF, no load	–	0.1	1.0	μA	3	
Input voltage	V _{IN}	—	1.5	–	5.5	V	–	
ON / OFF pin input voltage "H"	V _{SH}	V _{IN} = V _{OUT(S)} + 1.0 V, R _L = 1.0 kΩ	1.0	–	–	V	6, 7	
ON / OFF pin input voltage "L"	V _{SL}	V _{IN} = V _{OUT(S)} + 1.0 V, R _L = 1.0 kΩ	–	–	0.25	V	6, 7	
ON / OFF pin input current "H"	I _{SH}	V _{IN} = 5.5 V, V _{ON / OFF} = 5.5 V	A / B / C type (with constant current source pull-down)	0.15	0.30	0.60	μA	6, 7
			D / E / F type (without constant current source pull-down)	−0.1	–	0.1	μA	6, 7
ON / OFF pin input current "L"	I _{SL}	V _{IN} = 5.5 V, V _{ON / OFF} = 0 V	−0.1	–	0.1	μA	6, 7	
Ripple rejection	RR	V _{IN} = V _{OUT(S)} + 1.0 V, f = 1.0 kHz, ΔV _{rip} = 0.5 Vrms, I _{OUT} = 30 mA	1.0 V ≤ V _{OUT(S)} ≤ 2.0 V	–	75	–	dB	8, 9
			2.0 V < V _{OUT(S)} ≤ 3.0 V	–	72	–	dB	8, 9
			3.0 V < V _{OUT(S)} ≤ 3.6 V	–	70	–	dB	8, 9
Short-circuit current	I _{short}	V _{IN} = V _{OUT(S)} + 1.0 V, ON / OFF pin = ON, V _{OUT} = 0 V	–	40	–	mA	4, 5	

Table 10 (2 / 2)

(Ta = +25°C unless otherwise specified)

Item	Symbol	Condition	Min.	Typ.	Max.	Unit	Test Circuit	
Thermal shutdown detection temperature	T _{SD}	Junction temperature	–	160	–	°C	–	
Thermal shutdown release temperature	T _{SR}	Junction temperature	–	130	–	°C	–	
"L" output Nch ON-resistance (With discharge shunt function)	R _{LOW}	V _{IN} = 5.5 V, V _{OUT} = 0.1 V	VOUT2 pin of C / F type (with delay function)	–	12	–	Ω	4, 5
			VOUT1 pin of C / F type (with delay function) B / E type (without delay function)	–	50	–	Ω	4, 5
Delay time*6 (C / F type only)	t _{DELAY}	V _{IN} ≥ V _{OUT(S)} + 1.0 V, ON / OFF1 pin and ON / OFF2 pin are set to ON simultaneously, R _L = 1.0 kΩ, C _{L1} , C _{L2} = 0.22 μF	50	100	–	μs	10	

- *1. V_{OUT(S)}: Set output voltage
V_{OUT(E)}: Actual output voltage
Output voltage when fixing I_{OUT} (= 30 mA) and inputting V_{OUT(S)} + 1.0 V
- *2. The output current at which the output voltage becomes 95% of V_{OUT(E)} after gradually increasing the output current.
- *3. V_{drop} = V_{IN1} – (V_{OUT3} × 0.98)
V_{OUT3} is the output voltage when V_{IN} = V_{OUT(S)} + 1.0 V and I_{OUT} = 100 mA.
V_{IN1} is the input voltage at which the output voltage becomes 98% of V_{OUT3} after gradually decreasing the input voltage.
- *4. A change in the temperature of the output voltage [mV/°C] is calculated using the following equation.

$$\frac{\Delta V_{OUT}}{\Delta T_a} \text{ [mV/°C]}^{*1} = V_{OUT(S)} \text{ [V]}^{*2} \times \frac{\Delta V_{OUT}}{\Delta T_a \cdot V_{OUT}} \text{ [ppm/°C]}^{*3} \div 1000$$
 - *1. Change in temperature of output voltage
 - *2. Set output voltage
 - *3. Output voltage temperature coefficient
- *5. The output current can be at least this value.
Due to restrictions on the package power dissipation, this value may not be satisfied. Attention should be paid to the power dissipation of the package when the output current is large.
This specification is guaranteed by design.
- *6. Delay time shows the time period from when VOUT1 pin voltage reaches 50% of the set output voltage until VOUT2 pin voltage reaches 50% of the set output voltage, when the ON / OFF1 pin and the ON / OFF2 pin are set to ON simultaneously. Refer to "8. Delay function (S-13D1 Series C / F type)" in "■ Operation" for details.

■ Test Circuits

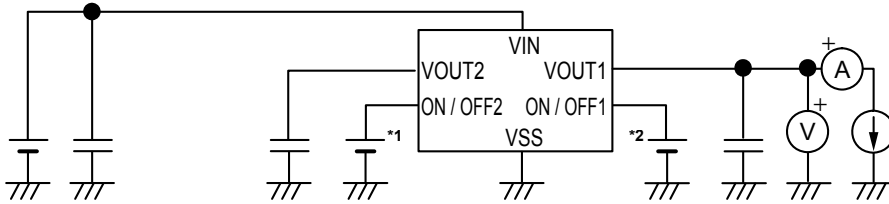

- *1. Set to OFF
- *2. Set to ON

Figure 11 Test Circuit 1

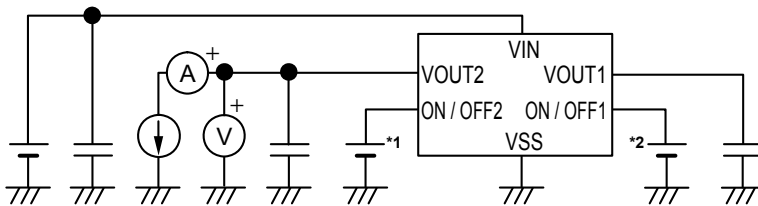

- *1. Set to ON
- *2. Set to OFF (set to ON in case of C / F type)

Figure 12 Test Circuit 2

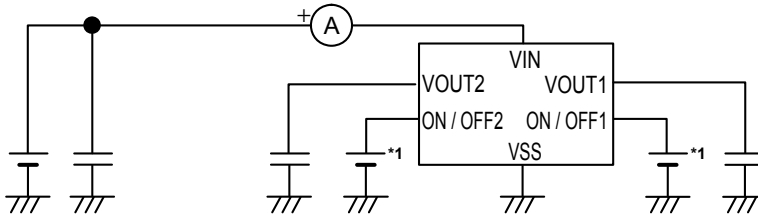

- *1. Set to V_{IN} or GND

Figure 13 Test Circuit 3

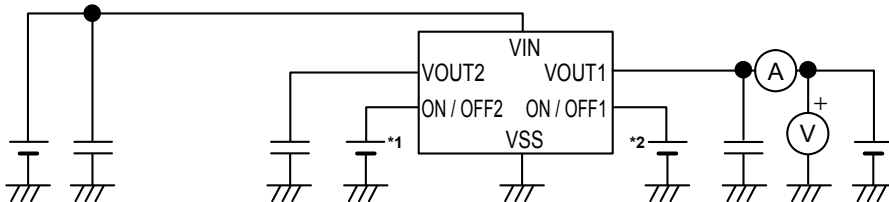

- *1. Set to OFF
- *2. Set to V_{IN} or GND

Figure 14 Test Circuit 4

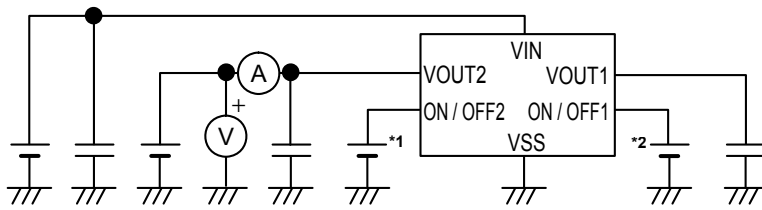

- *1. Set to V_{IN} or GND
- *2. Set to OFF (set to ON in case of C / F type)

Figure 15 Test Circuit 5

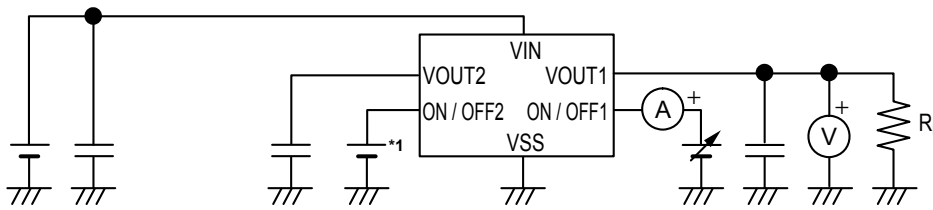

- *1. Set to OFF

Figure 16 Test Circuit 6

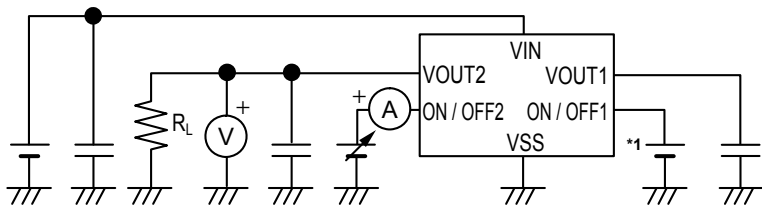

- *1. Set to OFF (set to ON in case of C / F type)

Figure 17 Test Circuit 7

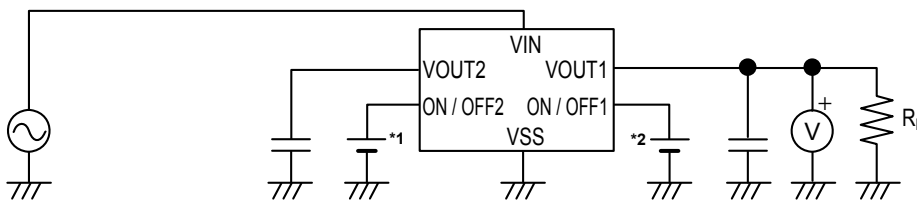

- *1. Set to OFF
- *2. Set to ON

Figure 18 Test Circuit 8

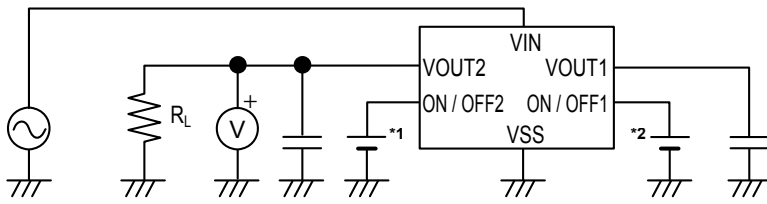

- *1. Set to ON
- *2. Set to OFF (set to ON in case of C / F type)

Figure 19 Test Circuit 9

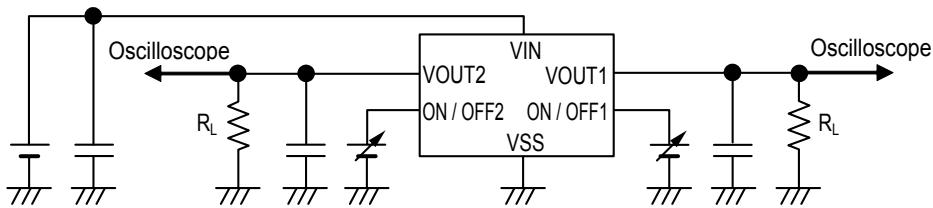
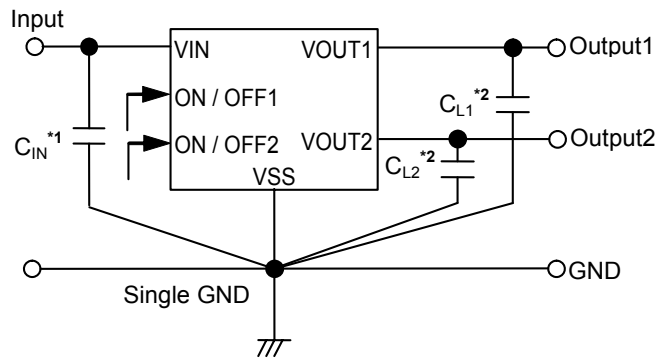

Figure 20 Test Circuit 10

■ Standard Circuit



- *1. C_{IN} is a capacitor for stabilizing the input.
- *2. A ceramic capacitor of $0.22 \mu\text{F}$ or more can be used as C_{L1} and C_{L2} .

Figure 21

Caution The above connection diagram and constant will not guarantee successful operation. Perform thorough evaluation using the actual application to set the constant.

■ Condition of Application

Input capacitor (C_{IN}): 0.22 μ F or more
 Output capacitors (C_{L1} , C_{L2}): 0.22 μ F or more

Caution Generally a series regulator may cause oscillation, depending on the selection of external parts. Confirm that no oscillation occurs in the application for which the above capacitors are used.

■ Selection of Input and Output Capacitors (C_{IN} , C_{L1} , C_{L2})

The S-13D1 Series requires an output capacitor between the V_{OUT} and V_{SS} pins for phase compensation. Operation is stabilized by a ceramic capacitor with an output capacitance of 0.22 μ F or more over the entire temperature range. When using an OS capacitor, a tantalum capacitor, or an aluminum electrolytic capacitor, the capacitance must be 0.22 μ F or more.

The value of the output overshoot or undershoot transient response varies depending on the value of the output capacitor. The required capacitance of the input capacitor differs depending on the application.

The recommended capacitance for an application is $C_{IN} \geq 0.22 \mu\text{F}$, $C_{L1} \geq 0.22 \mu\text{F}$, $C_{L2} \geq 0.22 \mu\text{F}$; however, when selecting the output capacitor, perform sufficient evaluation, including evaluation of temperature characteristics, on the actual device.

■ Explanation of Terms

1. Low dropout voltage regulator

This voltage regulator has the low dropout voltage due to its built-in low on-resistance transistor.

2. Output voltage (V_{OUT})

The accuracy of the output voltage is ensured at $\pm 1.0\%$ or $\pm 15 \text{ mV}^{*1}$ under the specified conditions of fixed input voltage^{*2}, fixed output current, and fixed temperature.

*1. When $V_{OUT} < 1.5 \text{ V}$: $\pm 15 \text{ mV}$, When $V_{OUT} \geq 1.5 \text{ V}$: $\pm 1.0\%$

*2. Differs depending on the product.

Caution If the above conditions change, the output voltage value may vary and exceed the accuracy range of the output voltage. Refer to "■ Electrical Characteristics (per Circuit)" and "■ Characteristics (Typical Data) (per Circuit)" for details.

3. Line regulation $\left(\frac{\Delta V_{OUT1}}{\Delta V_{IN} \cdot V_{OUT}} \right)$

Indicates the dependency of the output voltage on the input voltage. That is, the values show how much the output voltage changes due to a change in the input voltage with the output current remaining unchanged.

4. Load regulation (ΔV_{OUT2})

Indicates the dependency of the output voltage on the output current. That is, the values show how much the output voltage changes due to a change in the output current with the input voltage remaining unchanged.

5. Dropout voltage (V_{drop})

Indicates the difference between input voltage V_{IN1} and the output voltage when; decreasing input voltage V_{IN} gradually until the output voltage has dropped out to the value of 98% of output voltage V_{OUT3} , which is at $V_{IN} = V_{OUT(S)} + 1.0 \text{ V}$.

$$V_{drop} = V_{IN1} - (V_{OUT3} \times 0.98)$$

6. Output voltage temperature coefficient $\left(\frac{\Delta V_{OUT}}{\Delta T_a \bullet V_{OUT}}\right)$

The shaded area in **Figure 22** is the range where V_{OUT} varies in the operation temperature range when the output voltage temperature coefficient is ± 100 ppm/ $^{\circ}$ C.

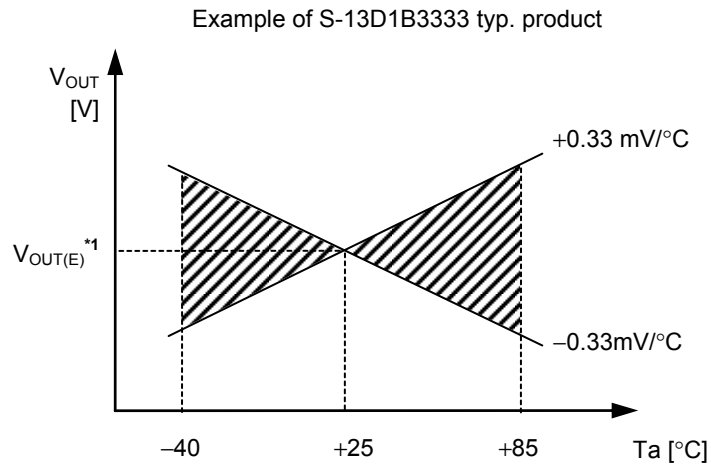

*1. $V_{OUT(E)}$ is the value of the output voltage measured at $T_a = +25^{\circ}$ C.

Figure 22

A change in the temperature of the output voltage [mV/ $^{\circ}$ C] is calculated using the following equation.

$$\frac{\Delta V_{OUT}}{\Delta T_a} \text{ [mV}/^{\circ}\text{C}]^{*1} = V_{OUT(S)} \text{ [V]}^{*2} \times \frac{\Delta V_{OUT}}{\Delta T_a \bullet V_{OUT}} \text{ [ppm}/^{\circ}\text{C}]^{*3} \div 1000$$

- *1. Change in temperature of output voltage
- *2. Set output voltage
- *3. Output voltage temperature coefficient

■ **Operation**

1. Basic operation

Figure 23 shows the block diagram of the S-13D1 Series.

The error amplifier compares the reference voltage (V_{ref}) with feedback voltage (V_{fb}), which is the output voltage resistance-divided by feedback resistors (R_s and R_f). It supplies the gate voltage necessary to maintain the constant output voltage which is not influenced by the input voltage and temperature change, to the output transistor.

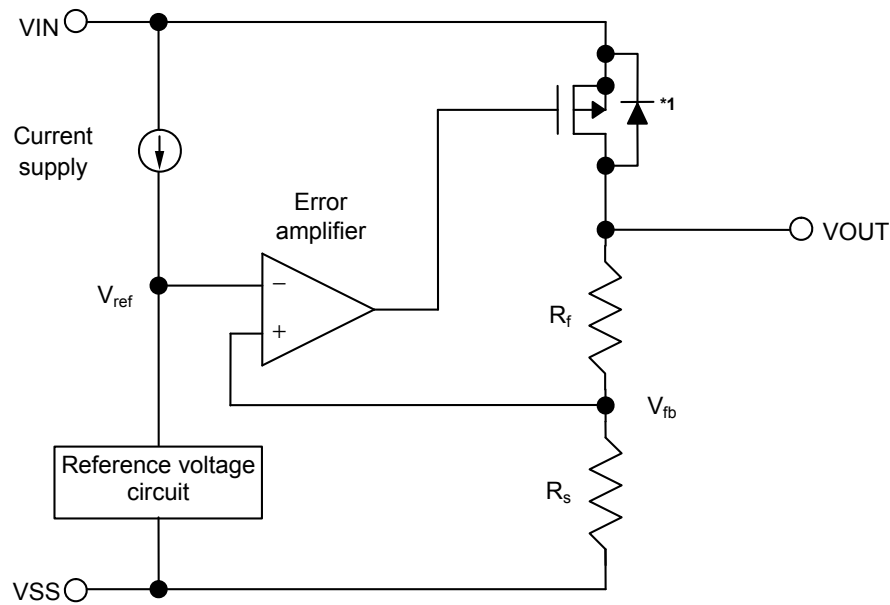

*1. Parasitic diode

Figure 23

2. Output transistor

In the S-13D1 Series, a low on-resistance P-channel MOS FET is used as the output transistor.

Be sure that V_{OUT} does not exceed $V_{IN} + 0.3$ V to prevent the voltage regulator from being damaged due to inverse current flowing from the VOUT pin through a parasitic diode to the VIN pin.

3. ON / OFF pin

This pin starts and stops the regulator.

When the ON / OFF pin is set to OFF level, the entire internal circuit stops operating, and the built-in P-channel MOS FET output transistor between the VIN and VOUT pins is turned off, reducing current consumption significantly.

Note that the current consumption increases when a voltage of 0.3 V to $V_{IN} - 0.3$ V is applied to the ON / OFF pin.

The ON / OFF pin is configured as shown in **Figure 24** and **Figure 25**.

3.1 S-13D1 Series A / B / C type

The ON / OFF pin is internally pulled down to the VSS pin in the floating status, so the VOUT pin is set to the V_{SS} level.

3.2 S-13D1 Series D / E / F type

The ON / OFF pin is not internally pulled down to the VSS pin, so do not use it in the floating status. When not using the ON / OFF pin, connect the pin to the VIN pin.

Table 11

Product Type	ON / OFF Pin	Internal Circuit	VOUT Pin Voltage	Current Consumption
A / B / C / D / E / F	"H": ON	Operate	Set value	I_{SS1} ^{*1}
A / B / C / D / E / F	"L": OFF	Stop	V_{SS} level	I_{SS2}

*1. Note that the IC's current consumption increases as much as current flows into the constant current of 0.3 μ A typ. when the ON / OFF pin is connected to VIN pin and the S-13D1 Series A / B / C type is operating (refer to **Figure 24**).

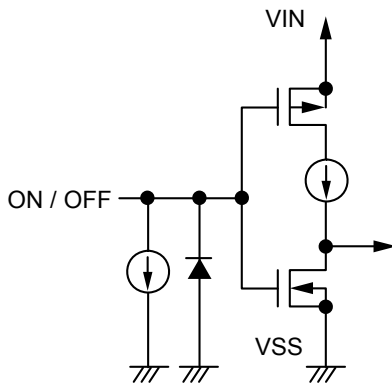

Figure 24 S-13D1 Series A / B / C Type

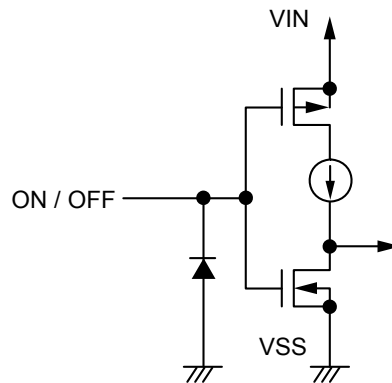

Figure 25 S-13D1 Series D / E / F Type

4. Discharge shunt function (S-13D1 Series B / C / E / F type)

The S-13D1 Series B / C / E / F type has a built-in discharge shunt circuit to discharge the output capacitance. The output capacitance is discharged as follows so that the VOUT pin reaches the V_{SS} level.

- (1) The ON / OFF pin is set to OFF level.
- (2) The output transistor is turned off.
- (3) The discharge shunt circuit is turned on.
- (4) The output capacitor discharges.

Since the S-13D1 Series A / D type does not have a discharge shunt circuit, the VOUT pin is set to the V_{SS} level through several hundred $k\Omega$ internal divided resistors between the VOUT and VSS pins. The S-13D1 Series B / C / E / F type allows the VOUT pin to reach the V_{SS} level rapidly due to the discharge shunt circuit.

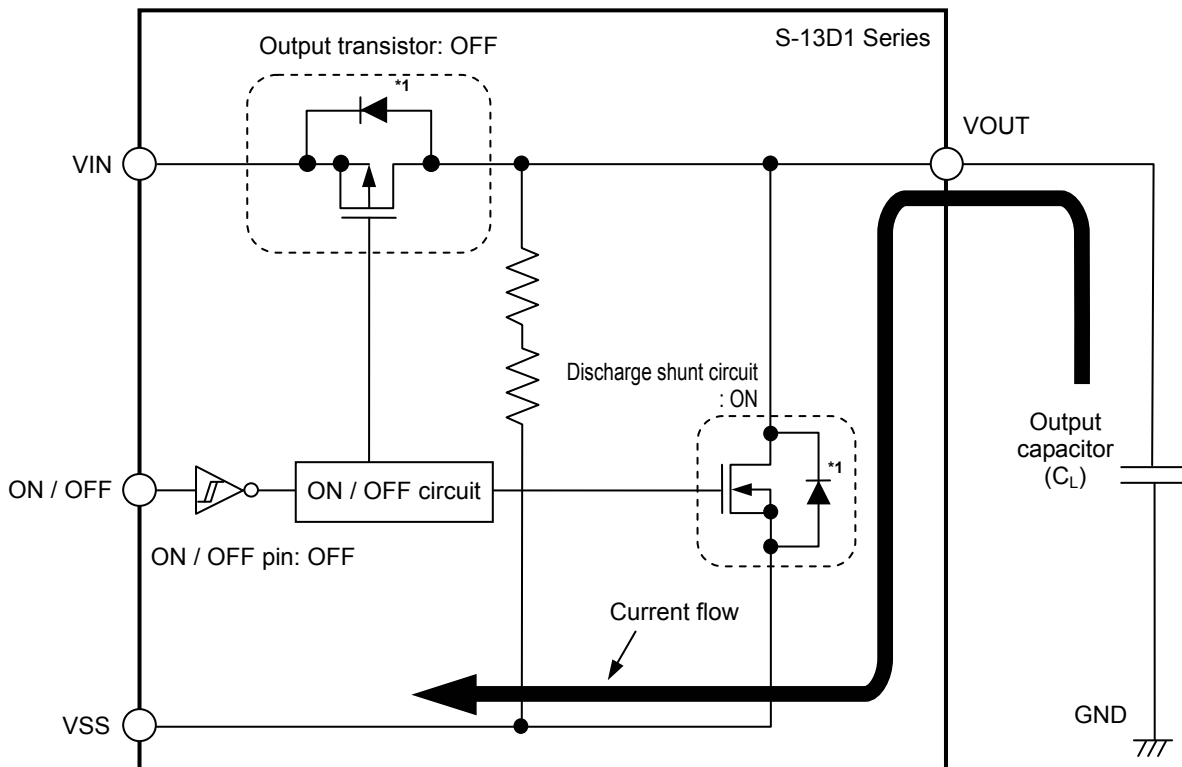

*1. Parasitic diode

Figure 26

Moreover, C / F type in the S-13D1 Series, if the ON / OFF1 pin and the ON / OFF2 pin are set to OFF simultaneously, the discharge shunt on-resistance connected with the VOUT2 pin is reduced in order to make it easy for VOUT2 pin voltage to fall previously.

Table 12

Product Type	Discharge Shunt ON-resistance ($V_{IN} = 5.5 \text{ V}$, $V_{OUT} = 0.1 \text{ V}$)
VOUT2 pin of C / F type	12 Ω
VOUT1 pin of C / F type, and B / E type	50 Ω

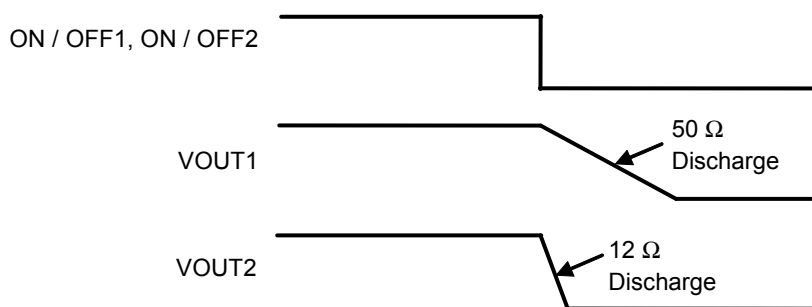

Figure 27 Discharge Shunt Function of S-13D1 Series C / F Type

5. Constant current source pull-down (S-13D1 Series A / B / C type)

The ON / OFF pin is internally pulled down to the VSS pin in the floating status, so the VOUT pin is set to the V_{SS} level.

Note that the IC's current consumption increases as much as current flows into the constant current of 0.3 μ A typ. when the ON / OFF pin is connected to the VIN pin and the S-13D1 Series A / B / C type is operating.

6. Overcurrent protection circuit

The S-13D1 Series includes an overcurrent protection circuit which has the characteristics shown in "1. Output voltage vs. Output current (When load current increases) (Ta = +25°C)" in "■ Characteristics (Typical Data) (per Circuit)", in order to protect the output transistor against an excessive output current and short circuiting between the VOUT and VSS pins. The current when the output pin is short-circuited (I_{short}) is internally set at approx. 40 mA typ., and the normal value is restored for the output voltage, if releasing a short circuit once.

Caution This overcurrent protection circuit does not work as for thermal protection. If this IC long keeps short circuiting inside, pay attention to the conditions of input voltage and load current so that, under the usage conditions including short circuit, the loss of the IC will not exceed power dissipation of the package.

7. Thermal shutdown circuit

The S-13D1 Series has a thermal shutdown circuit to protect the device from damage due to overheat. When the junction temperature rises to 160°C typ., the thermal shutdown circuit operates to stop regulating. When the junction temperature drops to 130°C typ., the thermal shutdown circuit is released to restart regulating.

Due to self-heating of the S-13D1 Series, if the thermal shutdown circuit starts operating, it stops regulating so that the output voltage drops. When regulation stops, the S-13D1 Series does not itself generate heat and the IC's temperature drops. When the temperature drops, the thermal shutdown circuit is released to restart regulating, thus the S-13D1 Series generates heat again. Repeating this procedure makes the waveform of the output voltage into a pulse-like form. Stop or restart of regulation continues unless decreasing either or both of the input voltage and the output current in order to reduce the internal power consumption, or decreasing the ambient temperature.

Table 13

Thermal Shutdown Circuit	VOUT Pin Voltage
Operate: 160°C typ.*1	V _{SS} level
Release: 130°C typ.*1	Set value

*1. Junction temperature

8. Delay function (S-13D1 Series C / F type)

C / F type in the S-13D1 Series has a built-in delay function that sets the difference of rising time between channels. If the ON / OFF1 pin and the ON / OFF2 pin are set to ON simultaneously, VOUT2 pin voltage rises after the delay time ($t_{DELAY} = 100 \mu s$ typ.).

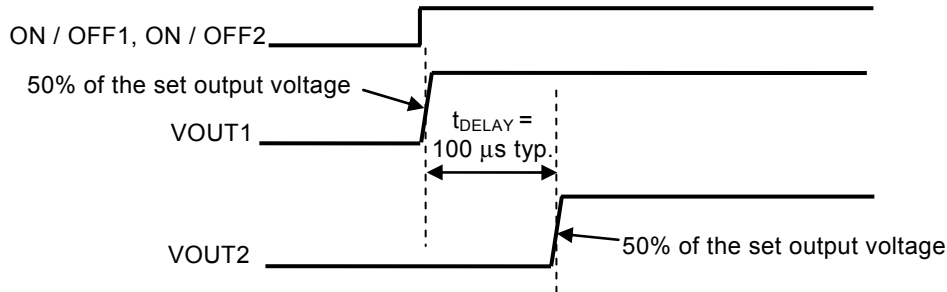

Figure 28

8.1 In case ON / OFF2 pin is set to ON later

The VOUT1 pin voltage rises simultaneously when the ON / OFF1 pin is set to ON. After the ON / OFF2 pin is set to ON, VOUT2 pin voltage rises in $100 \mu s$ typ.

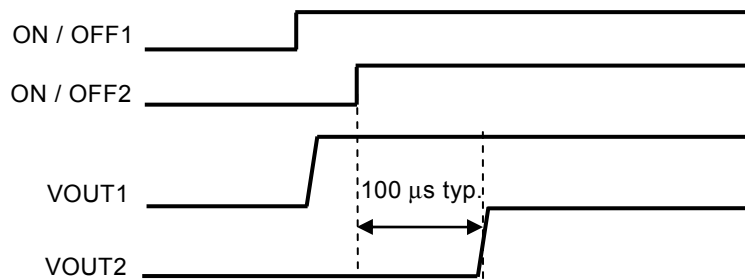

Figure 29

8.2 In case ON / OFF2 pin is set to ON previously

VOUT2 pin voltage does not rise even if the ON / OFF2 pin is set to ON. VOUT1 pin voltage rises if the ON / OFF1 pin is set to ON. After VOUT1 pin voltage rises, VOUT2 pin voltage rises in $100 \mu s$ typ.

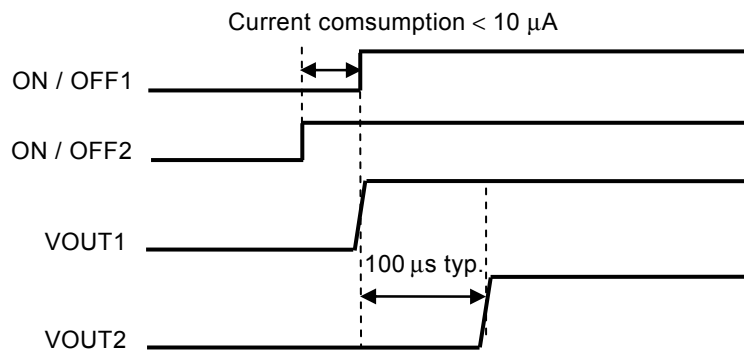

Figure 30

Caution Note that the current consumption of less than $10 \mu A$ flows during the time period from when the ON / OFF2 pin is set to ON until the ON / OFF1 pin is set to ON.

■ Precautions

- Wiring patterns for the VIN pin, the VOUT pin and GND should be designed so that the impedance is low. When mounting the output capacitors between the VOUT and VSS pins (C_{L1} , C_{L2}) and a capacitor for stabilizing the input between the VIN and VSS pins (C_{IN}), the distance from the capacitors to these pins should be as short as possible.
- Note that generally the output voltage may increase when a series regulator is used at low load current (1.0 mA or less).
- Note that generally the output voltage may increase due to the leakage current from an output driver when a series regulator is used at high temperature.
- Note that the output voltage may increase due to the leakage current from an output driver even if the ON / OFF pin is at OFF level when a series regulator is used at a high temperature.
- Generally a series regulator may cause oscillation, depending on the selection of external parts. The following conditions are recommended for the S-13D1 Series. However, be sure to perform sufficient evaluation under the actual usage conditions for selection, including evaluation of temperature characteristics. Refer to "6. Example of equivalent series resistance vs. Output current characteristics ($T_a = +25^\circ\text{C}$)" in "■ Reference Data (per Circuit)" for the equivalent series resistance (R_{ESR}) of the output capacitors.

Input capacitor (C_{IN}): 0.22 μF or more

Output capacitors (C_{L1} , C_{L2}): 0.22 μF or more

- The voltage regulator may oscillate when the impedance of the power supply is high and the input capacitance is small or an input capacitor is not connected.
- If the output capacitance is small, power supply's fluctuation and the characteristics of load fluctuation become worse. Sufficiently evaluate the output voltage's fluctuation with the actual device.
- Overshoot may occur in the output voltage momentarily if the voltage is rapidly raised at power-on or when the power supply fluctuates. Sufficiently evaluate the output voltage at power-on with the actual device.
- The application conditions for the input voltage, the output voltage, and the load current should not exceed the package power dissipation.
- Do not apply an electrostatic discharge to this IC that exceeds the performance ratings of the built-in electrostatic protection circuit.
- In determining the output current, attention should be paid to the output current value specified in **Table 10** in "■ Electrical Characteristics (per Circuit)" and footnote *5 of the table.
- SII claims no responsibility for any disputes arising out of or in connection with any infringement by products including this IC of patents owned by a third party.

■ Characteristics (Typical Data) (per Circuit)

1. Output voltage vs. Output current (When load current increases) (Ta = +25°C)

1.1 V_{OUT} = 1.0 V

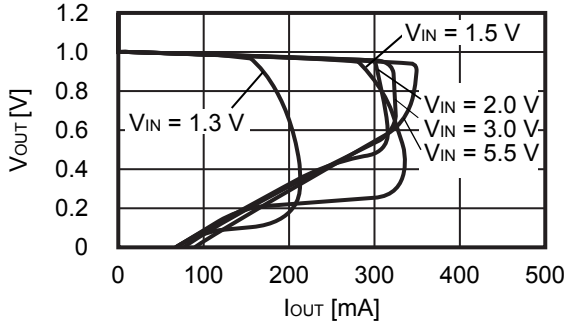

1.2 V_{OUT} = 2.5 V

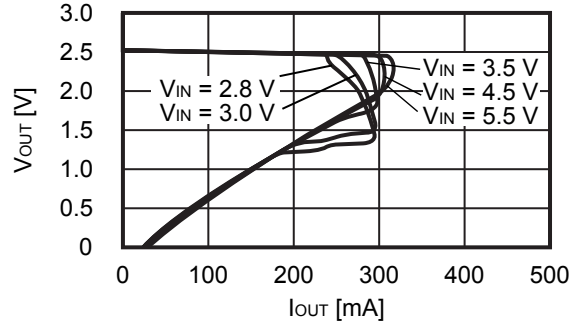

1.3 V_{OUT} = 3.6 V

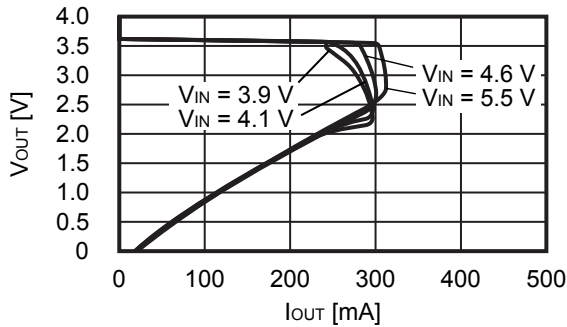

Remark In determining the output current, attention should be paid to the following.

1. The minimum output current value and footnote *5 in Table 10 in "■ Electrical Characteristics (per Circuit)"
2. The package power dissipation

2. Output voltage vs. Input voltage (Ta = +25°C)

2.1 V_{OUT} = 1.0 V

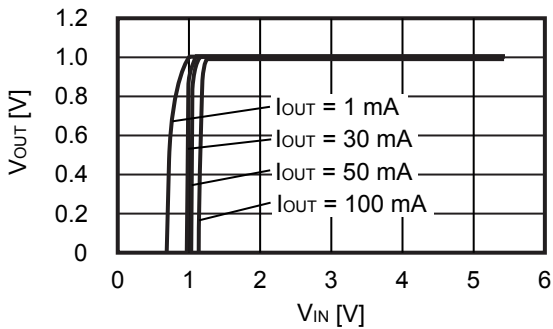

2.2 V_{OUT} = 2.5 V

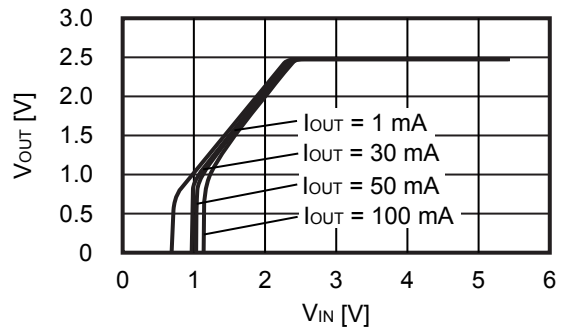

2.3 V_{OUT} = 3.6 V

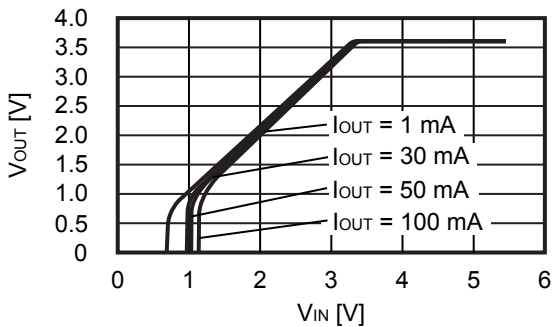

3. Dropout voltage vs. Output current

3.1 $V_{OUT} = 1.0\text{ V}$

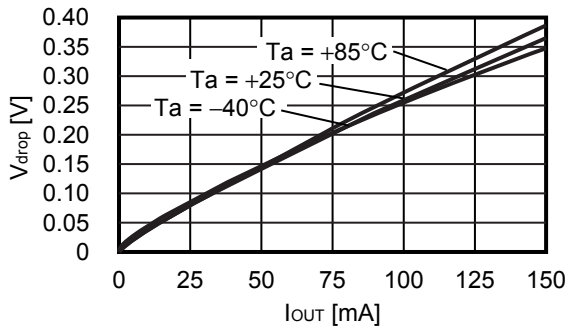

3.2 $V_{OUT} = 2.5\text{ V}$

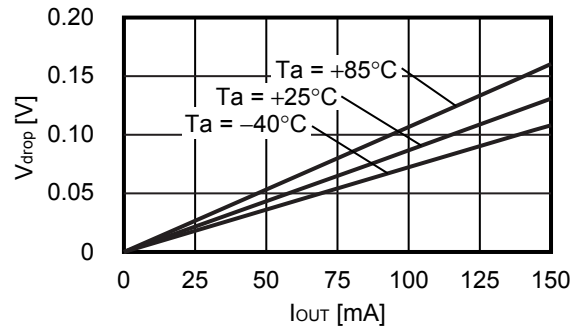

3.3 $V_{OUT} = 3.6\text{ V}$

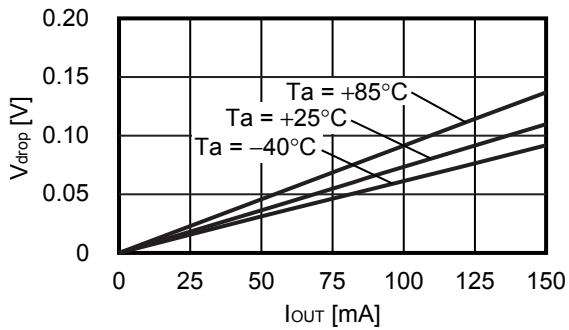

4. Dropout voltage vs. Set output voltage

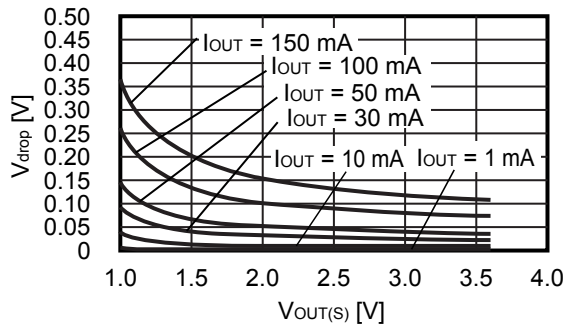

5. Output voltage vs. Ambient temperature

5.1 $V_{OUT} = 1.0\text{ V}$

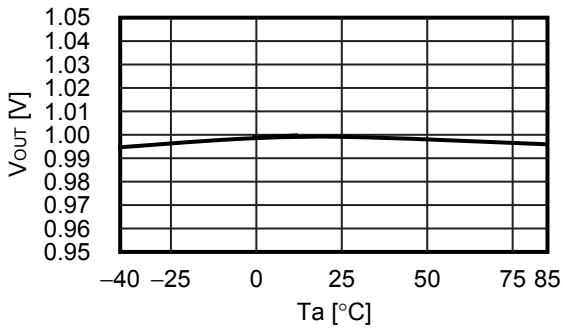

5.2 $V_{OUT} = 2.5\text{ V}$

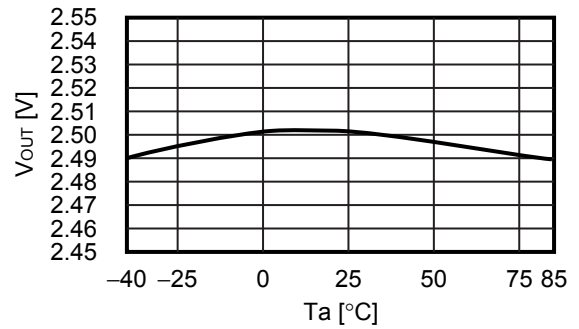

5.3 $V_{OUT} = 3.6\text{ V}$

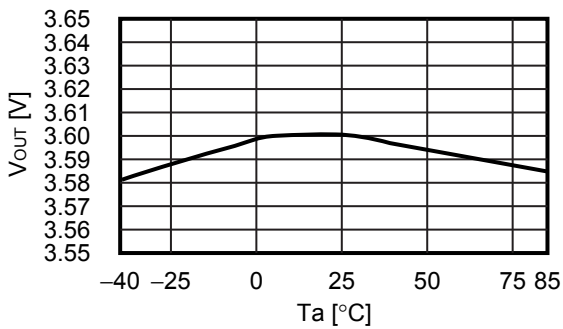

6. Current consumption vs. Input voltage

6.1 $V_{OUT} = 1.0\text{ V}$

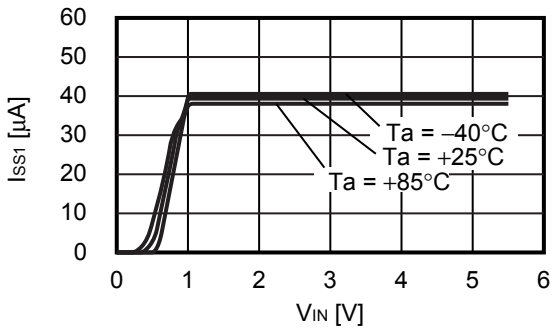

6.2 $V_{OUT} = 2.5\text{ V}$

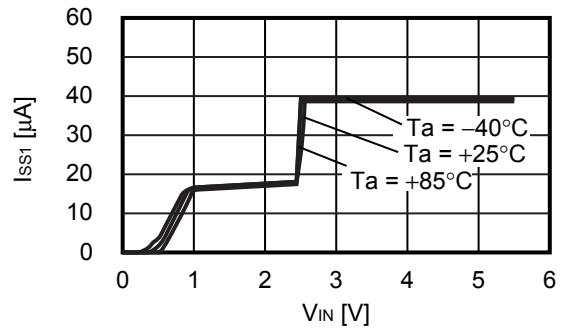

6.3 $V_{OUT} = 3.6\text{ V}$

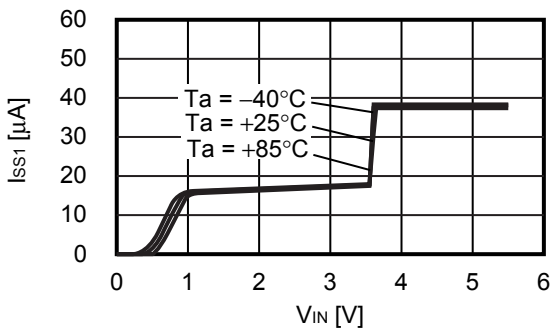

7. Ripple rejection (Ta = +25°C)

7.1 V_{OUT} = 1.0 V

V_{IN} = 2.0 V, C_{Ln} = 0.22 μF

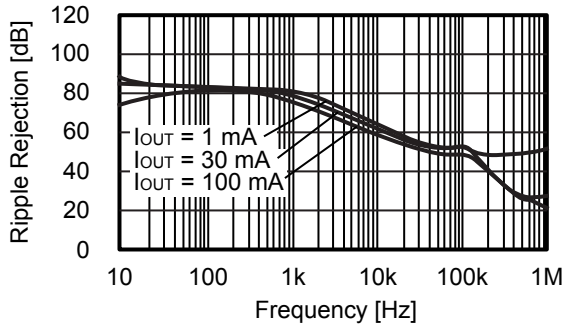

7.2 V_{OUT} = 2.5 V

V_{IN} = 3.5 V, C_{Ln} = 0.22 μF

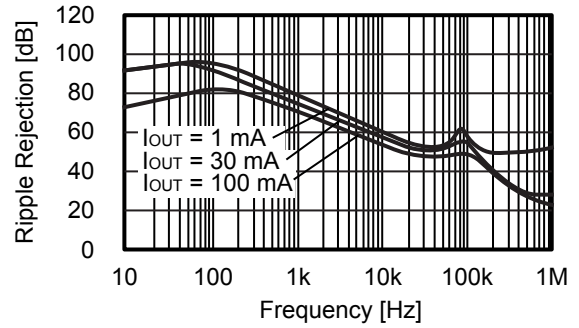

7.3 V_{OUT} = 3.6 V

V_{IN} = 4.6 V, C_{Ln} = 0.22 μF

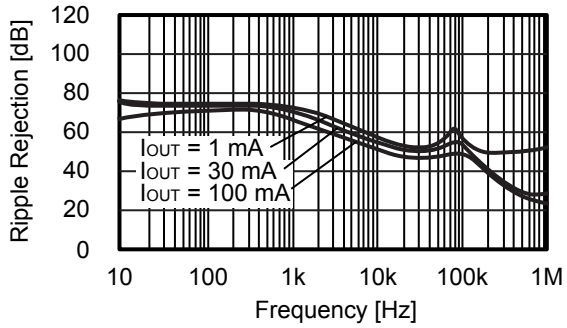

Remark C_{Ln}: Output capacitor set to the VOUTn pin externally (n = 1, 2)

■ Reference Data (per Circuit)

1. Transient response characteristics when input ($T_a = +25^\circ\text{C}$)

1.1 $V_{OUT} = 1.0\text{ V}$

$I_{OUT} = 30\text{ mA}$, $C_{IN} = C_{Ln} = 0.22\ \mu\text{F}$,
 $V_{IN} = 2.0\text{ V} \leftrightarrow 3.0\text{ V}$, $t_r = t_f = 5.0\ \mu\text{s}$

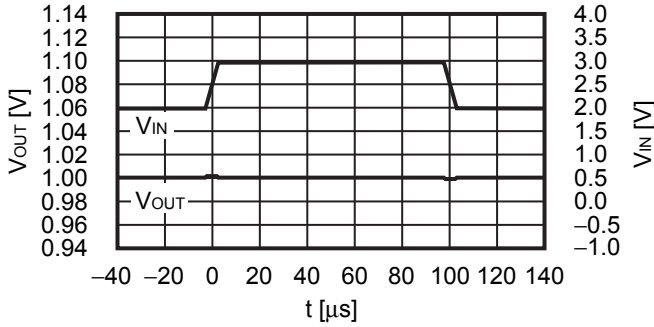

1.2 $V_{OUT} = 2.5\text{ V}$

$I_{OUT} = 30\text{ mA}$, $C_{Ln} = 0.22\ \mu\text{F}$,
 $V_{IN} = 3.5\text{ V} \leftrightarrow 4.5\text{ V}$, $t_r = t_f = 5.0\ \mu\text{s}$

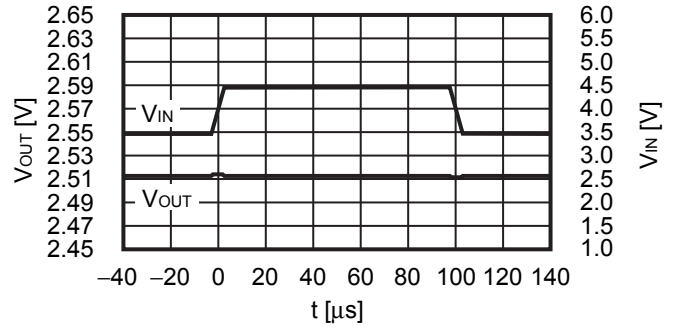

1.3 $V_{OUT} = 3.6\text{ V}$

$I_{OUT} = 30\text{ mA}$, $C_{Ln} = 0.22\ \mu\text{F}$,
 $V_{IN} = 4.6\text{ V} \leftrightarrow 5.5\text{ V}$, $t_r = t_f = 5.0\ \mu\text{s}$

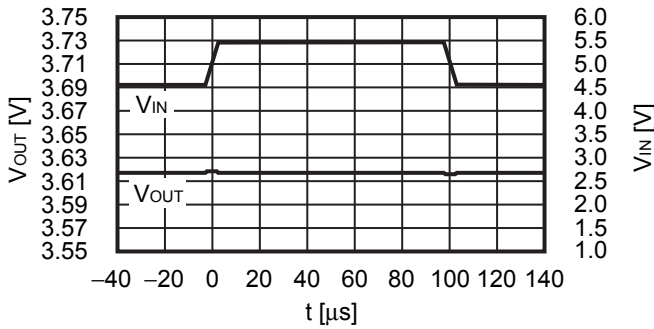

Remark C_{Ln} : Output capacitor set to the $VOUTn$ pin externally ($n = 1, 2$)

2. Transient response characteristics of load (Ta = +25°C)

2.1 V_{OUT} = 1.0 V

V_{IN} = 2.0 V, C_{IN} = C_{Ln} = 0.22 μF,
I_{OUT} = 50 mA ↔ 100 mA

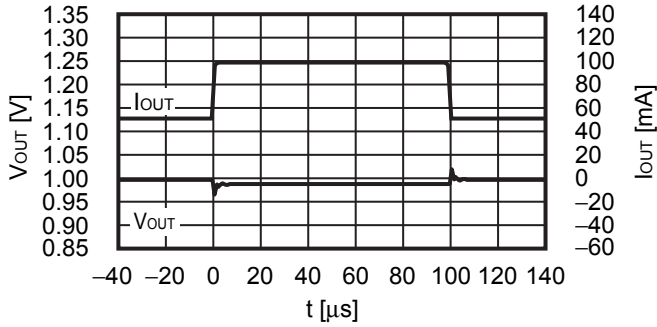

2.2 V_{OUT} = 2.5 V

V_{IN} = 3.5 V, C_{IN} = C_{Ln} = 0.22 μF,
I_{OUT} = 50 mA ↔ 100 mA

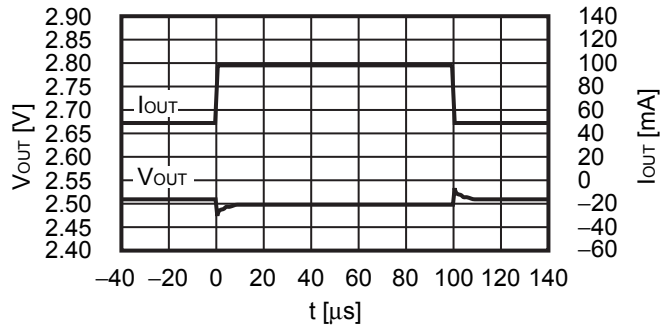

2.3 V_{OUT} = 3.6 V

V_{IN} = 4.6 V, C_{IN} = C_{Ln} = 0.22 μF,
I_{OUT} = 50 mA ↔ 100 mA

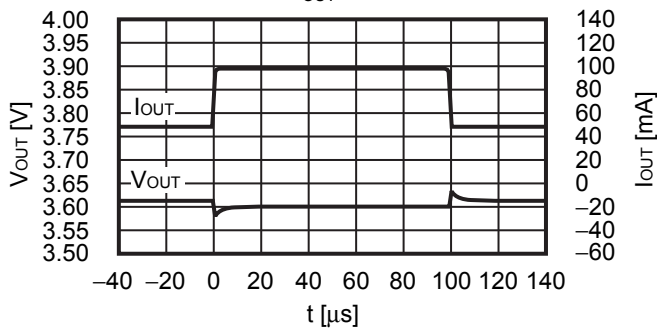

Remark C_{Ln}: Output capacitor set to the VOUTn pin externally (n = 1, 2)

3. Transient response characteristics of load's mutual interference (Ta = +25°C)

3.1 V_{OUT1} = V_{OUT2} = 1.0 V

V_{IN} = 2.0 V, C_{IN} = C_{Ln} = 0.22 μF, I_{OUT1} = 50 mA ↔ 100 mA

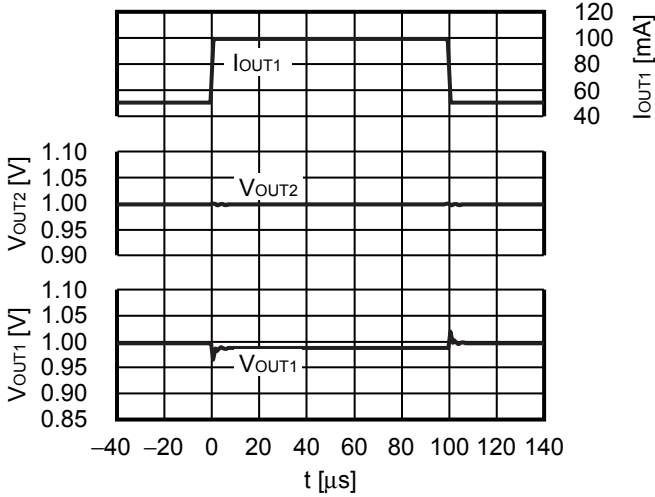

V_{IN} = 2.0 V, C_{IN} = C_{Ln} = 0.22 μF, I_{OUT2} = 50 mA ↔ 100 mA

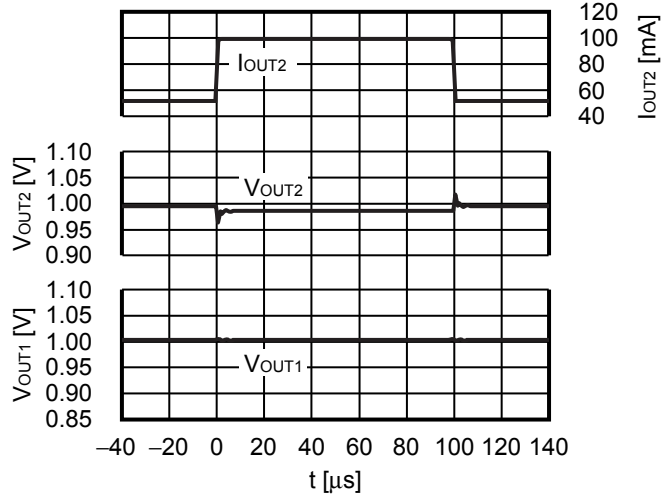

3.2 V_{OUT1} = V_{OUT2} = 2.5 V

V_{IN} = 3.5 V, C_{IN} = C_{Ln} = 0.22 μF, I_{OUT1} = 50 mA ↔ 100 mA

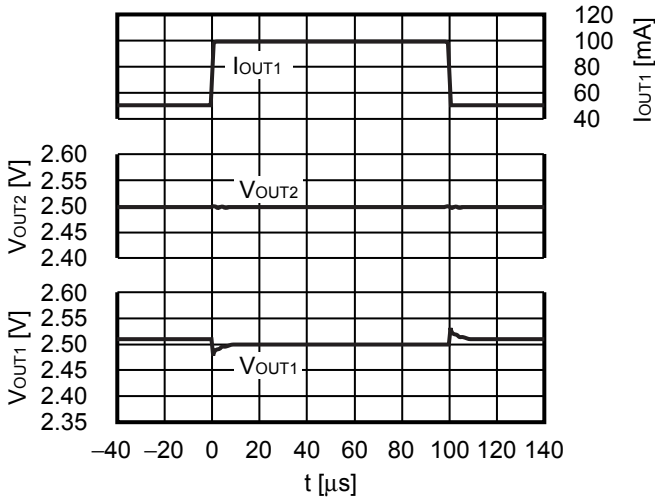

V_{IN} = 3.5 V, C_{IN} = C_{Ln} = 0.22 μF, I_{OUT2} = 50 mA ↔ 100 mA

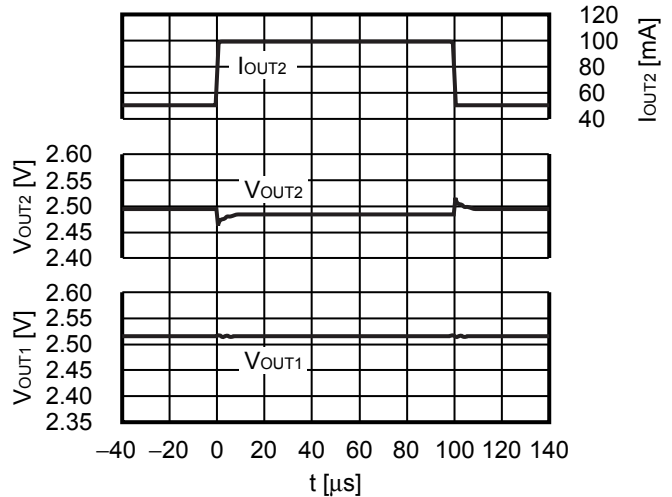

3.3 V_{OUT1} = V_{OUT2} = 3.6 V

V_{IN} = 4.6 V, C_{IN} = C_{Ln} = 0.22 μF, I_{OUT1} = 50 mA ↔ 100 mA

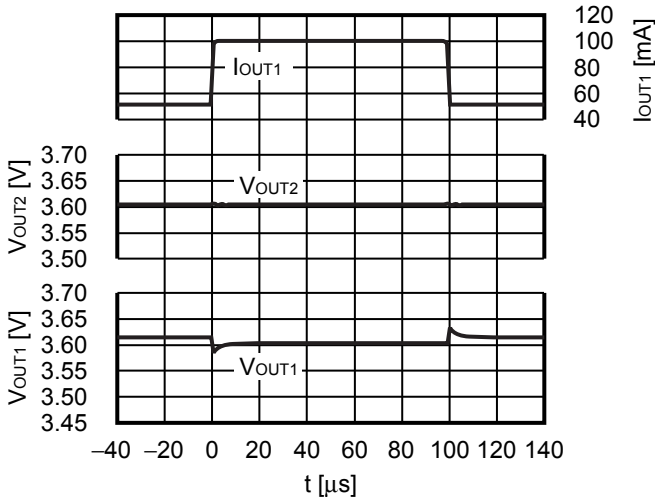

V_{IN} = 4.6 V, C_{IN} = C_{Ln} = 0.22 μF, I_{OUT2} = 50 mA ↔ 100 mA

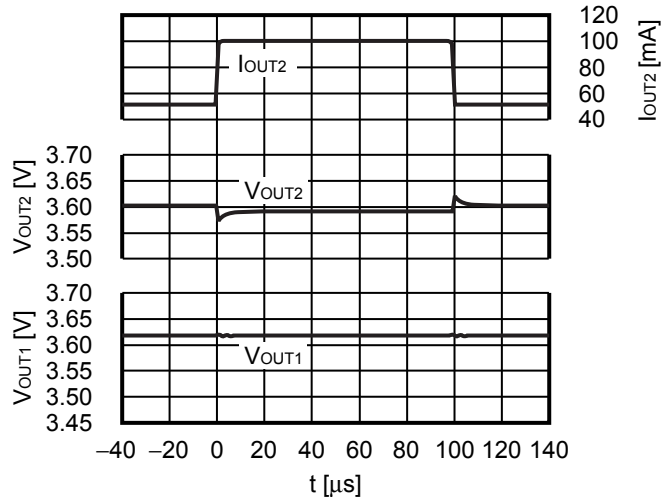

Remark C_{Ln}: Output capacitor set to the VOUTn pin externally (n = 1, 2)

4. Transient response characteristics of ON / OFF pin (Ta = +25°C)

4.1 S-13D1 Series A / B / D / E type (without delay function)

4.1.1 V_{OUT} = 1.0 V

V_{IN} = 2.0 V, C_{IN} = C_{Ln} = 0.22 μF, I_{OUT} = 30 mA,
 V_{ON/OFF} = 0 V → 2.0 V, t_r = 1.0 μs

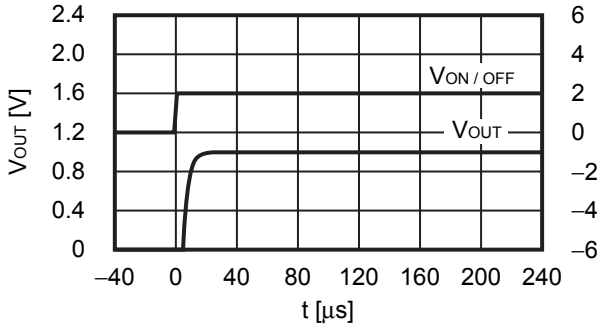

4.1.2 V_{OUT} = 2.5 V

V_{IN} = 3.5 V, C_{IN} = C_{Ln} = 0.22 μF, I_{OUT} = 30 mA,
 V_{ON/OFF} = 0 V → 3.5 V, t_r = 1.0 μs

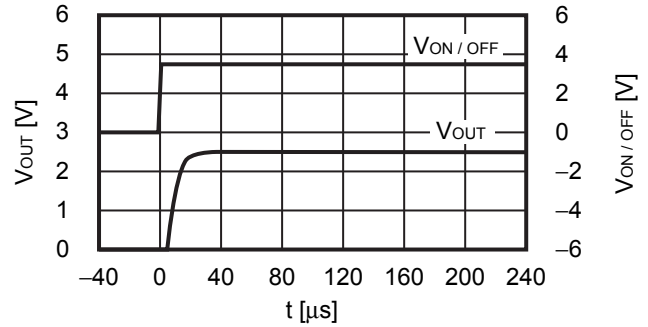

4.1.3 V_{OUT} = 3.6 V

V_{IN} = 4.6 V, C_{IN} = C_{Ln} = 0.22 μF, I_{OUT} = 30 mA,
 V_{ON/OFF} = 0 V → 4.6 V, t_r = 1.0 μs

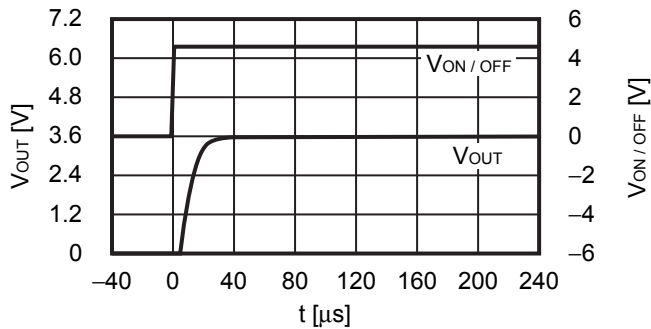

Remark C_{Ln}: Output capacitor set to the VOUTn pin externally (n = 1, 2)

4.2 S-13D1 Series C / F type (with delay function, when $V_{ON/OFF1}$ and $V_{ON/OFF2}$ are raised simultaneously)

4.2.1 $V_{OUT1} = V_{OUT2} = 1.0\text{ V}$

(1) V_{OUT1}

$V_{IN} = 2.0\text{ V}$, $C_{IN} = C_{L1} = 0.22\text{ }\mu\text{F}$, $I_{OUT} = 30\text{ mA}$,
 $V_{ON/OFF1} = 0\text{ V} \rightarrow 2.0\text{ V}$, $t_r = 1.0\text{ }\mu\text{s}$

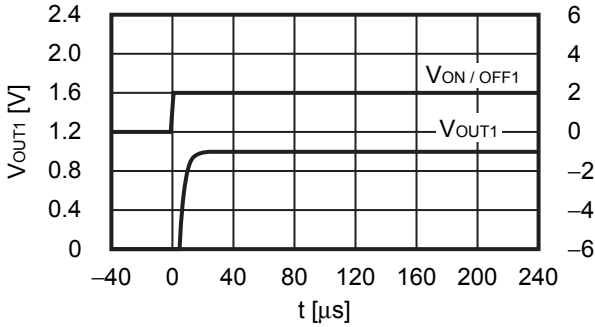

(2) V_{OUT2}

$V_{IN} = 2.0\text{ V}$, $C_{IN} = C_{L2} = 0.22\text{ }\mu\text{F}$, $I_{OUT} = 30\text{ mA}$,
 $V_{ON/OFF2} = 0\text{ V} \rightarrow 2.0\text{ V}$, $t_r = 1.0\text{ }\mu\text{s}$

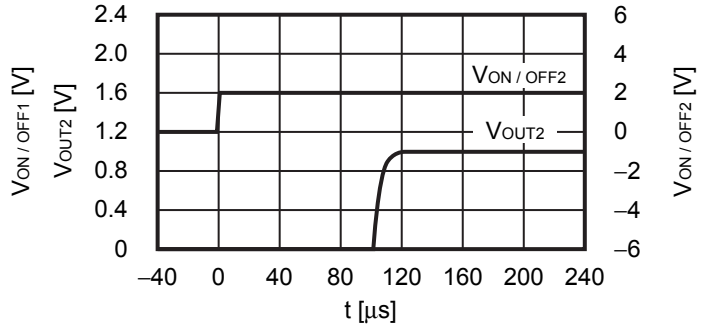

4.2.2 $V_{OUT1} = V_{OUT2} = 2.5\text{ V}$

(1) V_{OUT1}

$V_{IN} = 3.5\text{ V}$, $C_{IN} = C_{L1} = 0.22\text{ }\mu\text{F}$, $I_{OUT} = 30\text{ mA}$,
 $V_{ON/OFF1} = 0\text{ V} \rightarrow 3.5\text{ V}$, $t_r = 1.0\text{ }\mu\text{s}$

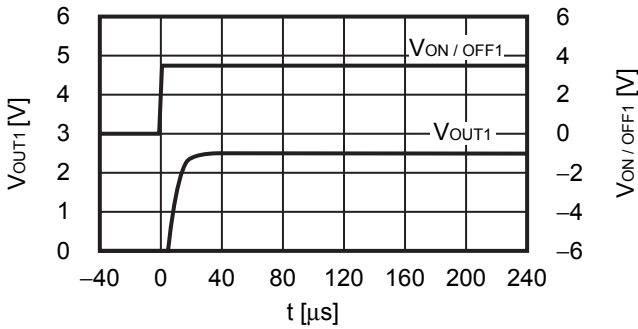

(2) V_{OUT2}

$V_{IN} = 3.5\text{ V}$, $C_{IN} = C_{L2} = 0.22\text{ }\mu\text{F}$, $I_{OUT} = 30\text{ mA}$,
 $V_{ON/OFF2} = 0\text{ V} \rightarrow 3.5\text{ V}$, $t_r = 1.0\text{ }\mu\text{s}$

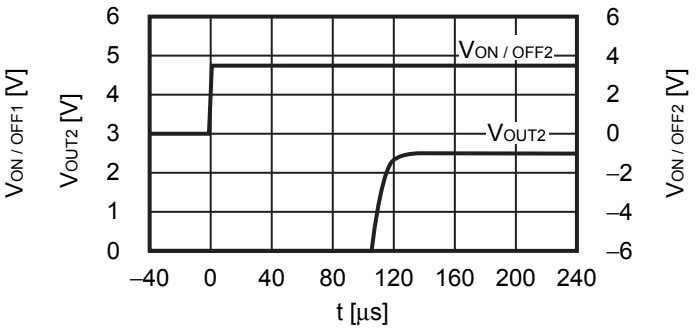

4.2.3 $V_{OUT1} = V_{OUT2} = 3.6\text{ V}$

(1) V_{OUT1}

$V_{IN} = 4.6\text{ V}$, $C_{IN} = C_{L1} = 0.22\text{ }\mu\text{F}$, $I_{OUT} = 30\text{ mA}$,
 $V_{ON/OFF1} = 0\text{ V} \rightarrow 4.6\text{ V}$, $t_r = 1.0\text{ }\mu\text{s}$

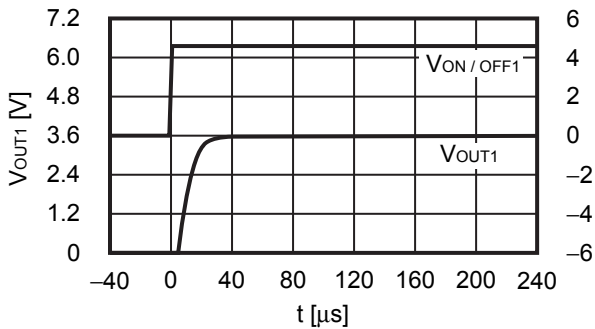

(2) V_{OUT2}

$V_{IN} = 4.6\text{ V}$, $C_{IN} = C_{L2} = 0.22\text{ }\mu\text{F}$, $I_{OUT} = 30\text{ mA}$,
 $V_{ON/OFF2} = 0\text{ V} \rightarrow 4.6\text{ V}$, $t_r = 1.0\text{ }\mu\text{s}$

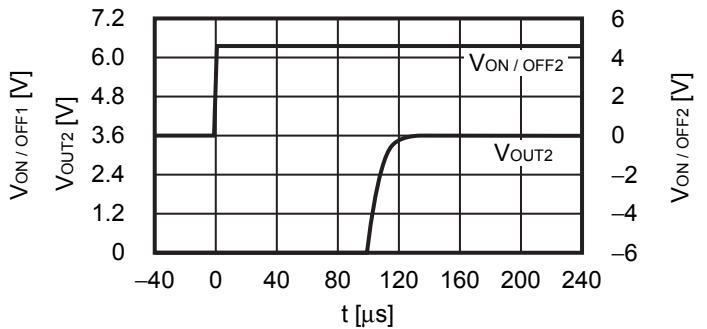

5. Output capacitance vs. Characteristics of discharge time (Ta = +25°C)

5.1 S-13D1 Series B / E type (with discharge shunt function, without delay function)

5.1.1 V_{OUT}

$V_{IN} = V_{OUT} + 1.0\text{ V}$, $I_{OUT} = \text{no load}$,
 $V_{ON/OFF} = V_{OUT} + 1.0\text{ V} \rightarrow V_{SS}$, $t_f = 1.0\ \mu\text{s}$

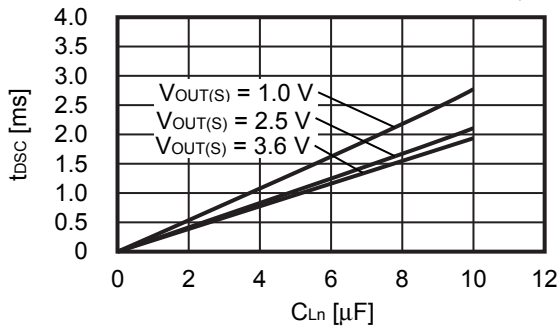

Figure 31

5.2 S-13D1 Series C / F type (with discharge shunt function, with delay function)

5.2.1 V_{OUT1}

$V_{IN} = V_{OUT1} + 1.0\text{ V}$, $I_{OUT1} = \text{no load}$,
 $V_{ON/OFF1} = V_{OUT1} + 1.0\text{ V} \rightarrow V_{SS}$, $t_f = 1.0\ \mu\text{s}$

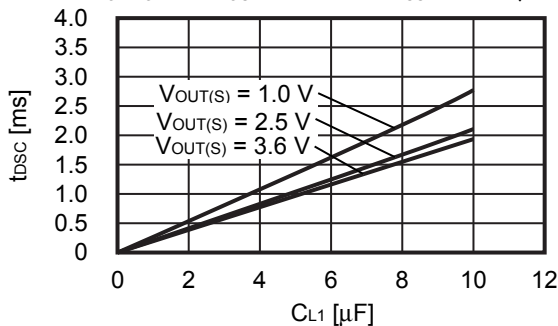

Figure 32

5.2.2 V_{OUT2}

$V_{IN} = V_{OUT2} + 1.0\text{ V}$, $I_{OUT2} = \text{no load}$,
 $V_{ON/OFF2} = V_{OUT2} + 1.0\text{ V} \rightarrow V_{SS}$, $t_f = 1.0\ \mu\text{s}$

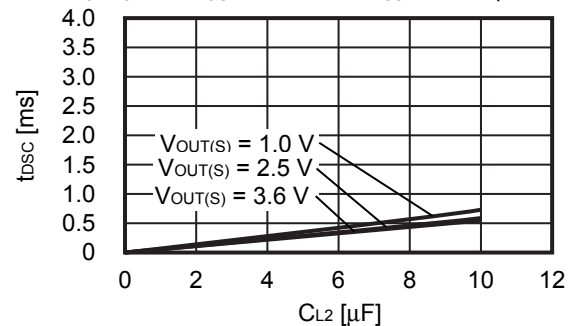

Figure 33

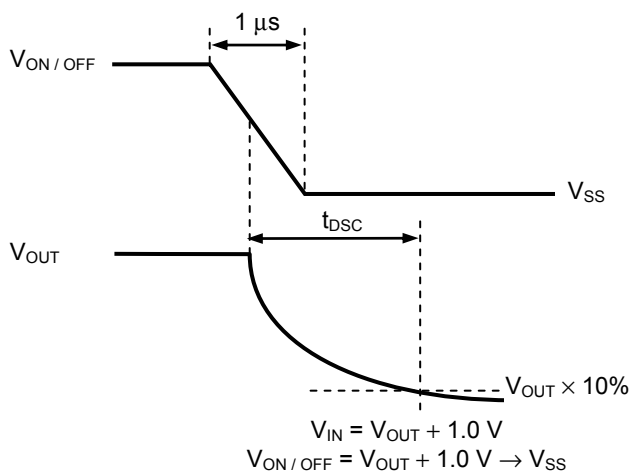

Figure 34 Measurement Condition of Discharge Time

Remark CL_n: Output capacitor set to the VOUT_n pin externally (n = 1, 2)

6. Example of equivalent series resistance vs. Output current characteristics ($T_a = +25^\circ\text{C}$)

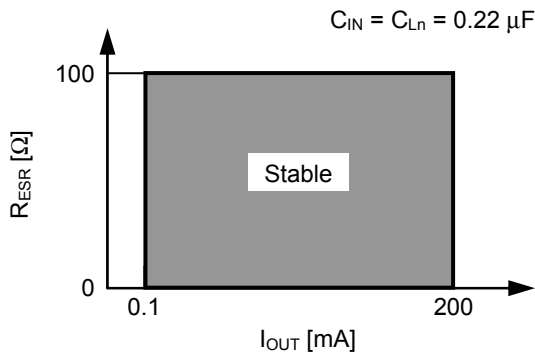
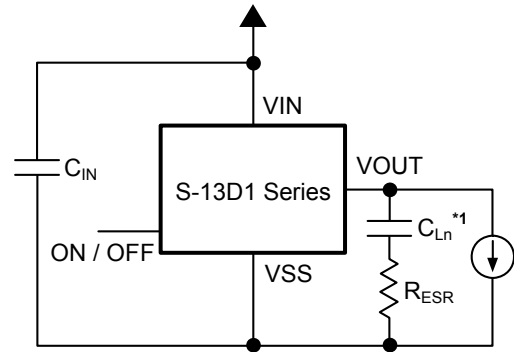

Figure 35



*1. C_{Ln} : TDK Corporation C2012X7R1H224K (0.22 μF)

Figure 36

Remark C_{Ln} : Output capacitor set to the VOUTn pin externally ($n = 1, 2$)

■ **Marking Specifications**

1. **SOT-23-6**

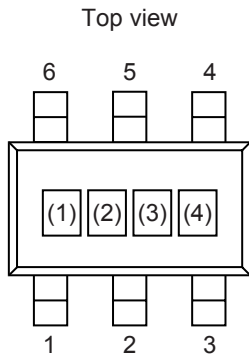

(1) to (3): Product code (Refer to **Product name vs. Product code**)
 (4): Lot number

Product name vs. Product code

1.1 **S-13D1 Series B type**

Product Name	Product Code		
	(1)	(2)	(3)
S-13D1B1218-M6T1U3	1	5	K
S-13D1B1528-M6T1U3	1	6	B
S-13D1B1812-M6T1U3	1	5	G
S-13D1B1815-M6T1U3	1	5	H
S-13D1B1818-M6T1U3	1	5	L
S-13D1B1828-M6T1U3	1	5	N
S-13D1B1833-M6T1U3	1	6	A
S-13D1B2518-M6T1U3	1	5	J
S-13D1B2818-M6T1U3	1	5	F
S-13D1B2828-M6T1U3	1	5	O
S-13D1B2833-M6T1U3	1	5	P
S-13D1B2J2J-M6T1U3	1	5	Q
S-13D1B3018-M6T1U3	1	5	A
S-13D1B3130-M6T1U3	1	5	D
S-13D1B3330-M6T1U3	1	5	C
S-13D1B3333-M6T1U3	1	5	B

1.2 **S-13D1 Series C type**

Product Name	Product Code		
	(1)	(2)	(3)
S-13D1C1218-M6T1U3	1	5	U
S-13D1C1528-M6T1U3	1	5	3
S-13D1C1818-M6T1U3	1	5	V
S-13D1C1828-M6T1U3	1	5	X
S-13D1C1833-M6T1U3	1	5	2
S-13D1C2828-M6T1U3	1	5	Y
S-13D1C2833-M6T1U3	1	5	Z
S-13D1C2J2J-M6T1U3	1	5	1
S-13D1C3636-M6T1U3	1	5	S

1.3 **S-13D1 Series D type**

Product Name	Product Code		
	(1)	(2)	(3)
S-13D1D1218-M6T1U3	1	7	A
S-13D1D1528-M6T1U3	1	7	H
S-13D1D1818-M6T1U3	1	7	B
S-13D1D1828-M6T1U3	1	7	C
S-13D1D1833-M6T1U3	1	7	G
S-13D1D2828-M6T1U3	1	7	D
S-13D1D2833-M6T1U3	1	7	E
S-13D1D2J2J-M6T1U3	1	7	F

2. HSNT-6 (1212)

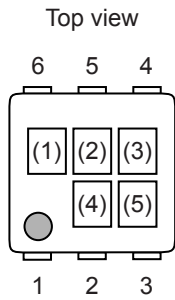

(1) to (3): Product code (Refer to **Product name vs. Product code**)
 (4), (5): Lot number

Product name vs. Product code

2.1 S-13D1 Series B type

Product Name	Product Code		
	(1)	(2)	(3)
S-13D1B1218-A6T2U3	1	5	K
S-13D1B1528-A6T2U3	1	6	B
S-13D1B1812-A6T2U3	1	5	G
S-13D1B1815-A6T2U3	1	5	H
S-13D1B1818-A6T2U3	1	5	L
S-13D1B1828-A6T2U3	1	5	N
S-13D1B1833-A6T2U3	1	6	A
S-13D1B2518-A6T2U3	1	5	J
S-13D1B2818-A6T2U3	1	5	F
S-13D1B2828-A6T2U3	1	5	O
S-13D1B2833-A6T2U3	1	5	P
S-13D1B2J2J-A6T2U3	1	5	Q
S-13D1B3018-A6T2U3	1	5	A
S-13D1B3130-A6T2U3	1	5	D
S-13D1B3330-A6T2U3	1	5	C
S-13D1B3333-A6T2U3	1	5	B

2.2 S-13D1 Series C type

Product Name	Product Code		
	(1)	(2)	(3)
S-13D1C1218-A6T2U3	1	5	U
S-13D1C1528-A6T2U3	1	5	3
S-13D1C1818-A6T2U3	1	5	V
S-13D1C1828-A6T2U3	1	5	X
S-13D1C1833-A6T2U3	1	5	2
S-13D1C2828-A6T2U3	1	5	Y
S-13D1C2833-A6T2U3	1	5	Z
S-13D1C2J2J-A6T2U3	1	5	1
S-13D1C3636-A6T2U3	1	5	S

2.3 S-13D1 Series D type

Product Name	Product Code		
	(1)	(2)	(3)
S-13D1D1218-A6T2U3	1	7	A
S-13D1D1528-A6T2U3	1	7	H
S-13D1D1818-A6T2U3	1	7	B
S-13D1D1828-A6T2U3	1	7	C
S-13D1D1833-A6T2U3	1	7	G
S-13D1D2828-A6T2U3	1	7	D
S-13D1D2833-A6T2U3	1	7	E
S-13D1D2J2J-A6T2U3	1	7	F

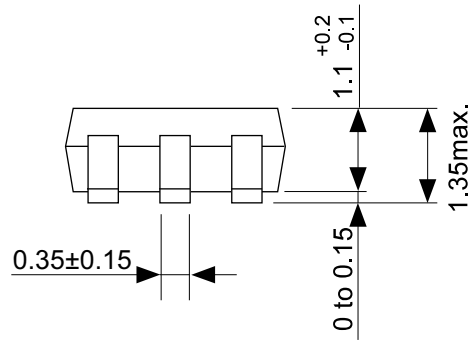
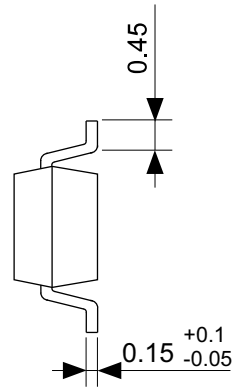
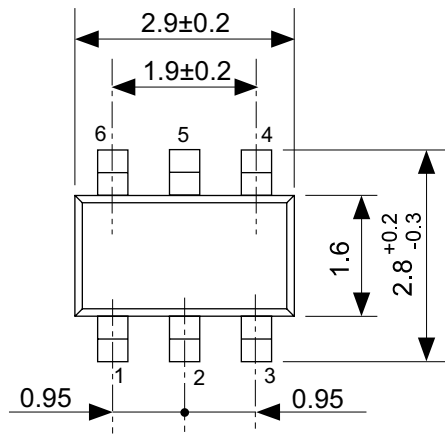

No. MP006-A-P-SD-2.0

TITLE	SOT236-A-PKG Dimensions
No.	MP006-A-P-SD-2.0
SCALE	
UNIT	mm
Seiko Instruments Inc.	

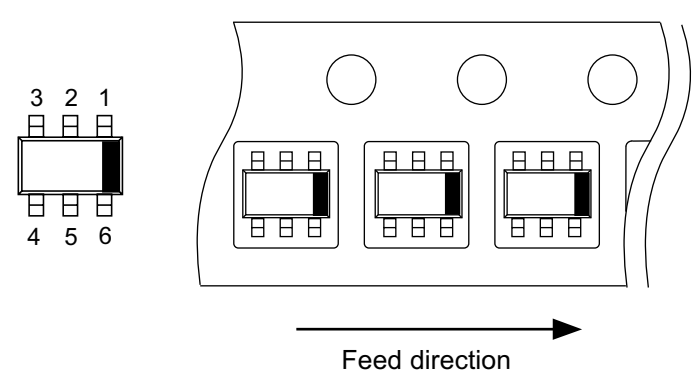
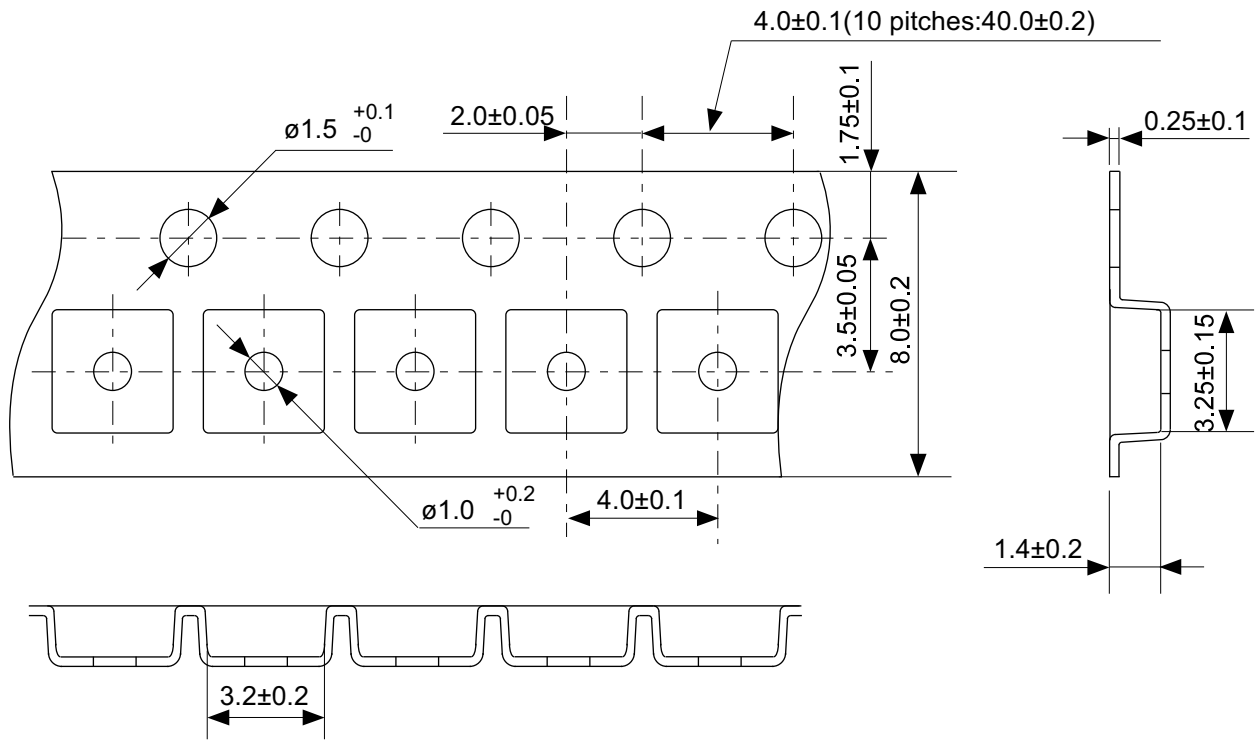

No. MP006-A-C-SD-3.1

TITLE	SOT236-A-Carrier Tape
No.	MP006-A-C-SD-3.1
SCALE	
UNIT	mm
Seiko Instruments Inc.	

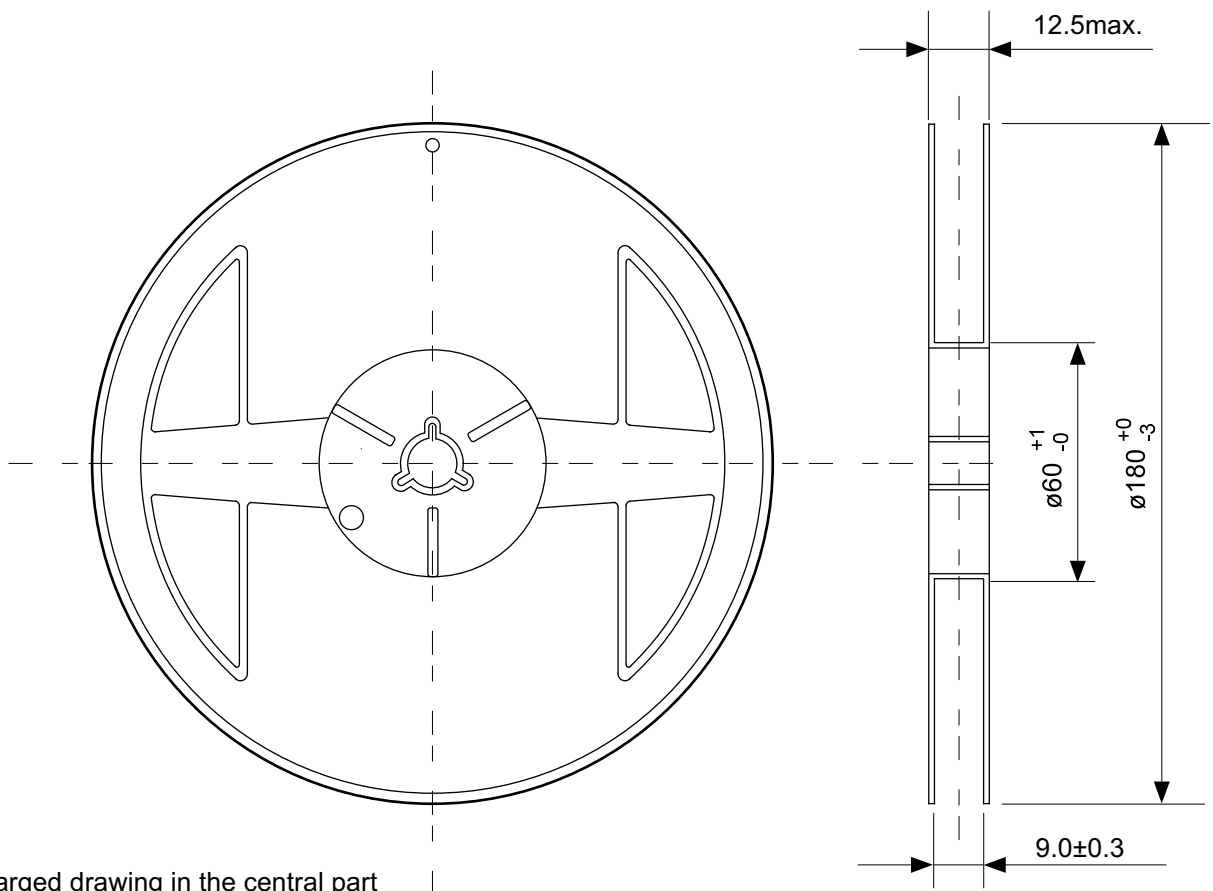

Enlarged drawing in the central part

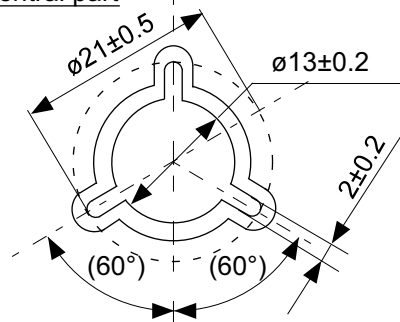

No. MP006-A-R-SD-2.1

TITLE	SOT236-A-Reel		
No.	MP006-A-R-SD-2.1		
SCALE		QTY	3,000
UNIT	mm		
Seiko Instruments Inc.			

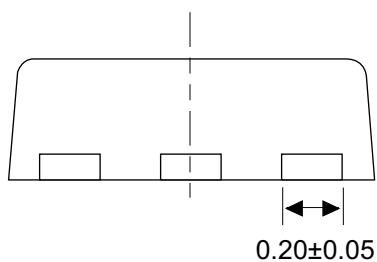
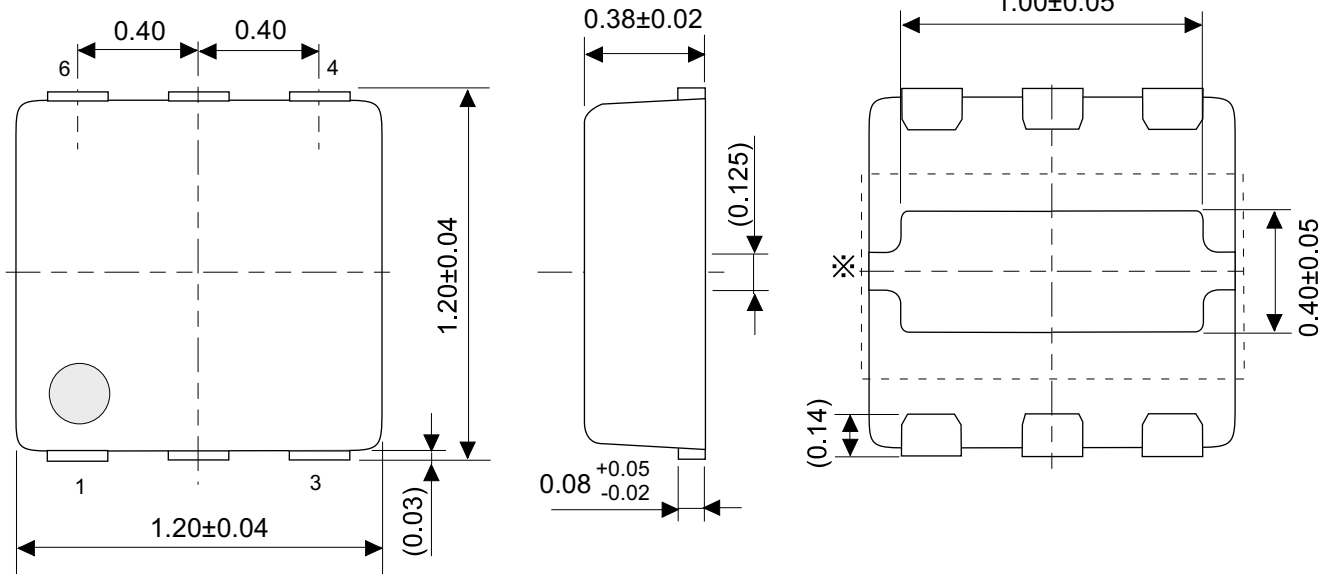

※ The heatsink of back side has different electric potential depending on the product. Confirm specifications of each product. Do not use it as the function of electrode.

No. PM006-A-P-SD-1.0

TITLE	HSNT-6-B-PKG Dimensions
No.	PM006-A-P-SD-1.0
SCALE	
UNIT	mm
Seiko Instruments Inc.	

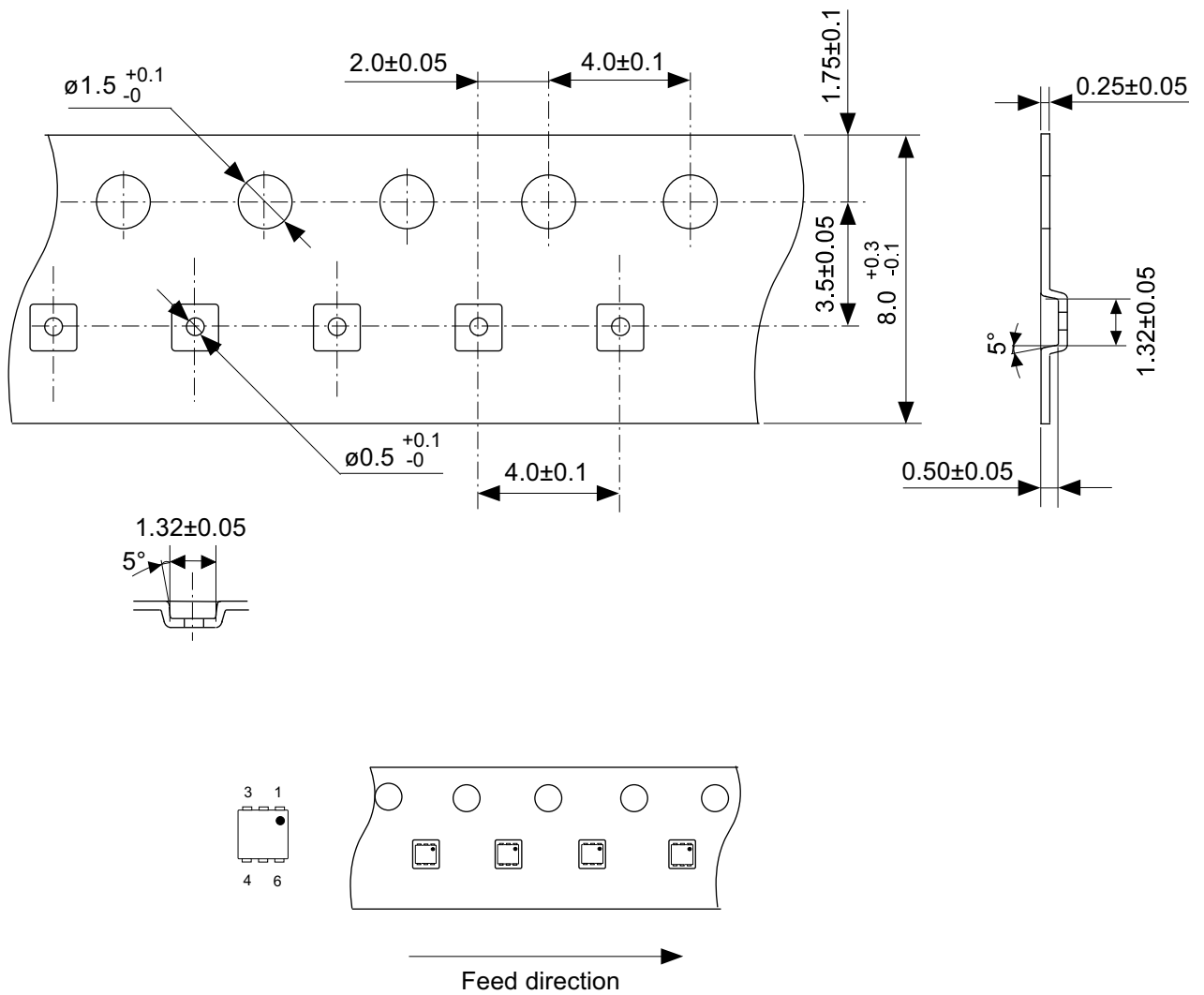

No. PM006-A-C-SD-1.0

TITLE	HSNT-6-B-Carrier Tape
No.	PM006-A-C-SD-1.0
SCALE	
UNIT	mm
Seiko Instruments Inc.	

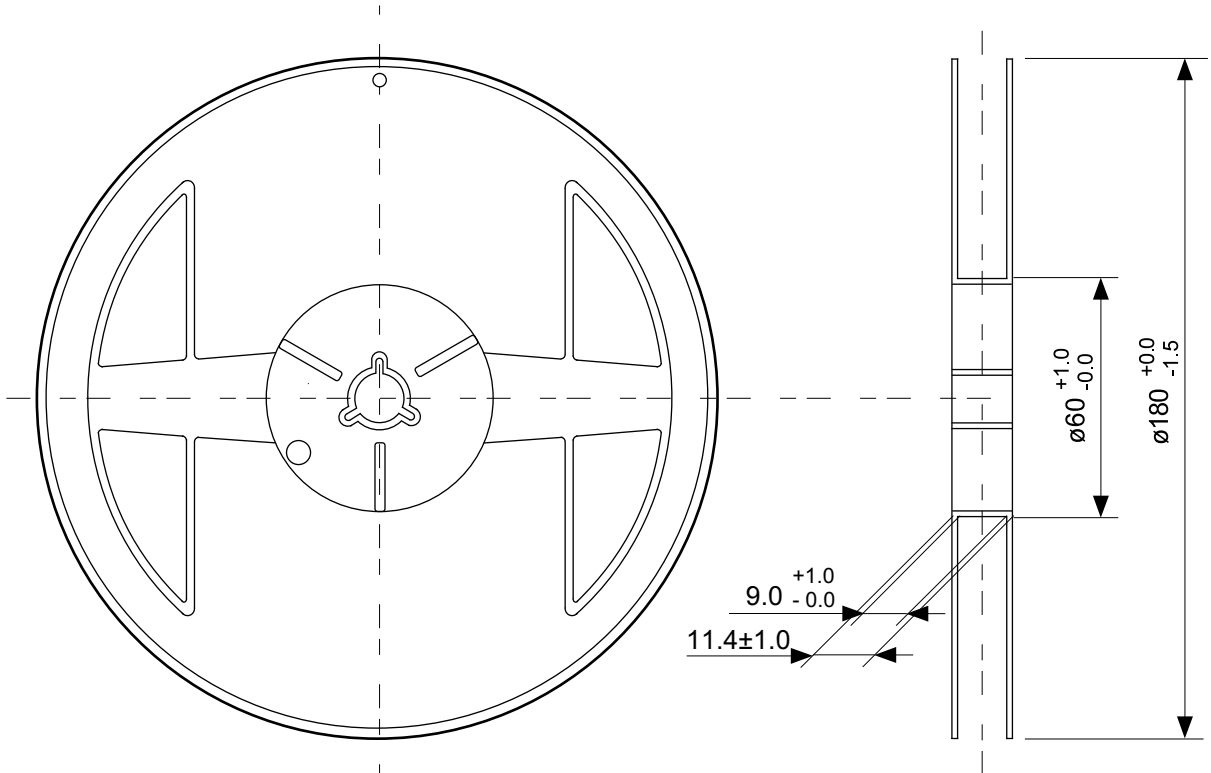

Enlarged drawing in the central part

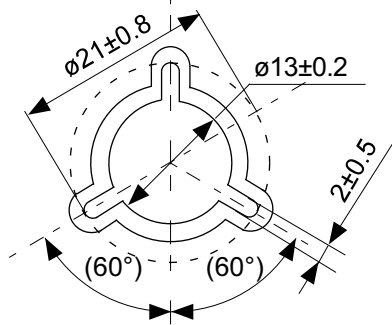

No. PM006-A-R-SD-1.0

TITLE	HSNT-6-B-Reel		
No.	PM006-A-R-SD-1.0		
SCALE		QTY.	5,000
UNIT	mm		
Seiko Instruments Inc.			

Land Pattern

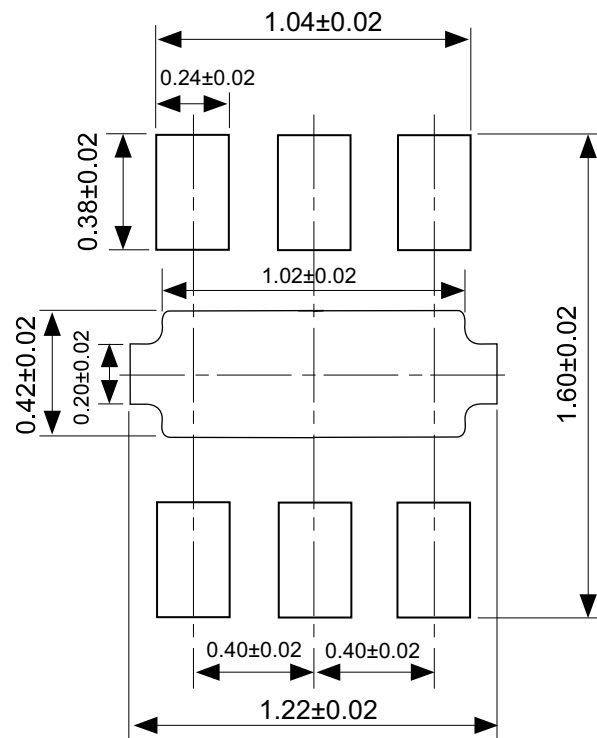

Caution It is recommended to solder the heatsink to a board in order to ensure the heat radiation.

注意 放熱性を確保する為に、PKGの裏面放熱板(ヒートシンク)を基板に半田付けする事を推奨いたします。

Metal Mask Pattern

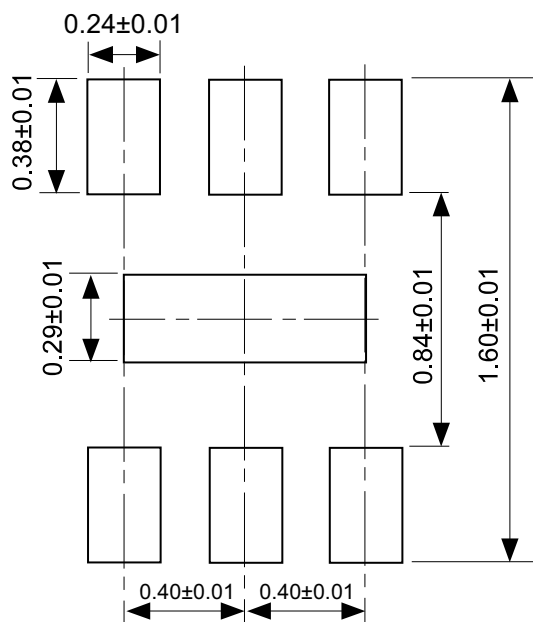

No. PM006-A-L-SD-1.0

TITLE	HSNT-6-B-Land Recommendation
No.	PM006-A-L-SD-1.0
SCALE	
UNIT	mm
Seiko Instruments Inc.	



Seiko Instruments Inc.
www.sii-ic.com

- The information described herein is subject to change without notice.
- Seiko Instruments Inc. is not responsible for any problems caused by circuits or diagrams described herein whose related industrial properties, patents, or other rights belong to third parties. The application circuit examples explain typical applications of the products, and do not guarantee the success of any specific mass-production design.
- When the products described herein are regulated products subject to the Wassenaar Arrangement or other agreements, they may not be exported without authorization from the appropriate governmental authority.
- Use of the information described herein for other purposes and/or reproduction or copying without the express permission of Seiko Instruments Inc. is strictly prohibited.
- The products described herein cannot be used as part of any device or equipment affecting the human body, such as exercise equipment, medical equipment, security systems, gas equipment, vehicle equipment, in-vehicle equipment, aviation equipment, aerospace equipment, and nuclear-related equipment, without prior written permission of Seiko Instruments Inc.
- The products described herein are not designed to be radiation-proof.
- Although Seiko Instruments Inc. exerts the greatest possible effort to ensure high quality and reliability, the failure or malfunction of semiconductor products may occur. The user of these products should therefore give thorough consideration to safety design, including redundancy, fire-prevention measures, and malfunction prevention, to prevent any accidents, fires, or community damage that may ensue.