

The S-35392A is a CMOS 2-wire real-time clock IC which operates with the very low current consumption and in the wide range of operation voltage. The operation voltage is 1.3 V to 5.5 V so that the S-35392A can be used for various power supplies from main supply to backup battery. Due to the 0.45 μ A current consumption and wide range of power supply voltage at time keeping, the S-35392A makes the battery life longer. In the system which operates with a backup battery, the included free registers can be used as the function for user's backup memory. Users always can take back the information in the registers which is stored before power-off the main power supply, after the voltage is restored.

The S-35392A has the function to correct advance / delay of the clock data speed, in the wide range, which is caused by the oscillation circuit's frequency deviation. Correcting according to the temperature change by combining this function and a temperature sensor, it is possible to make a high precise clock function which is not affected by the ambient temperature.

■ Features

- Low current consumption: 0.45 μ A typ. ($V_{DD} = 3.0$ V, $T_a = +25^\circ\text{C}$)
- Constant output of 32.768 kHz clock pulse (Nch open-drain output)
- Wide range of operating voltage: 1.3 V to 5.5 V
- Built-in clock correction function
- Built-in free user register
- 2-wire (I^2C -bus) CPU interface
- Built-in alarm interrupter
- Built-in flag generator during detection of low power voltage or at power-on
- Auto calendar up to the year 2099, automatic leap year calculation function
- Built-in constant voltage circuit
- Built-in 32.768 kHz crystal oscillator (C_d built in, C_g external)
- Lead-free, Sn 100%, halogen-free^{*1}

*1. Refer to "■ Product Name Structure" for details.

■ Applications

- Mobile game device
- Mobile AV device
- Digital still camera
- Digital video camera
- Electronic power meter
- DVD recorder
- TV, VCR
- Mobile phone, PHS
- Car navigation system

■ Package

- SNT-8A

■ Block Diagram

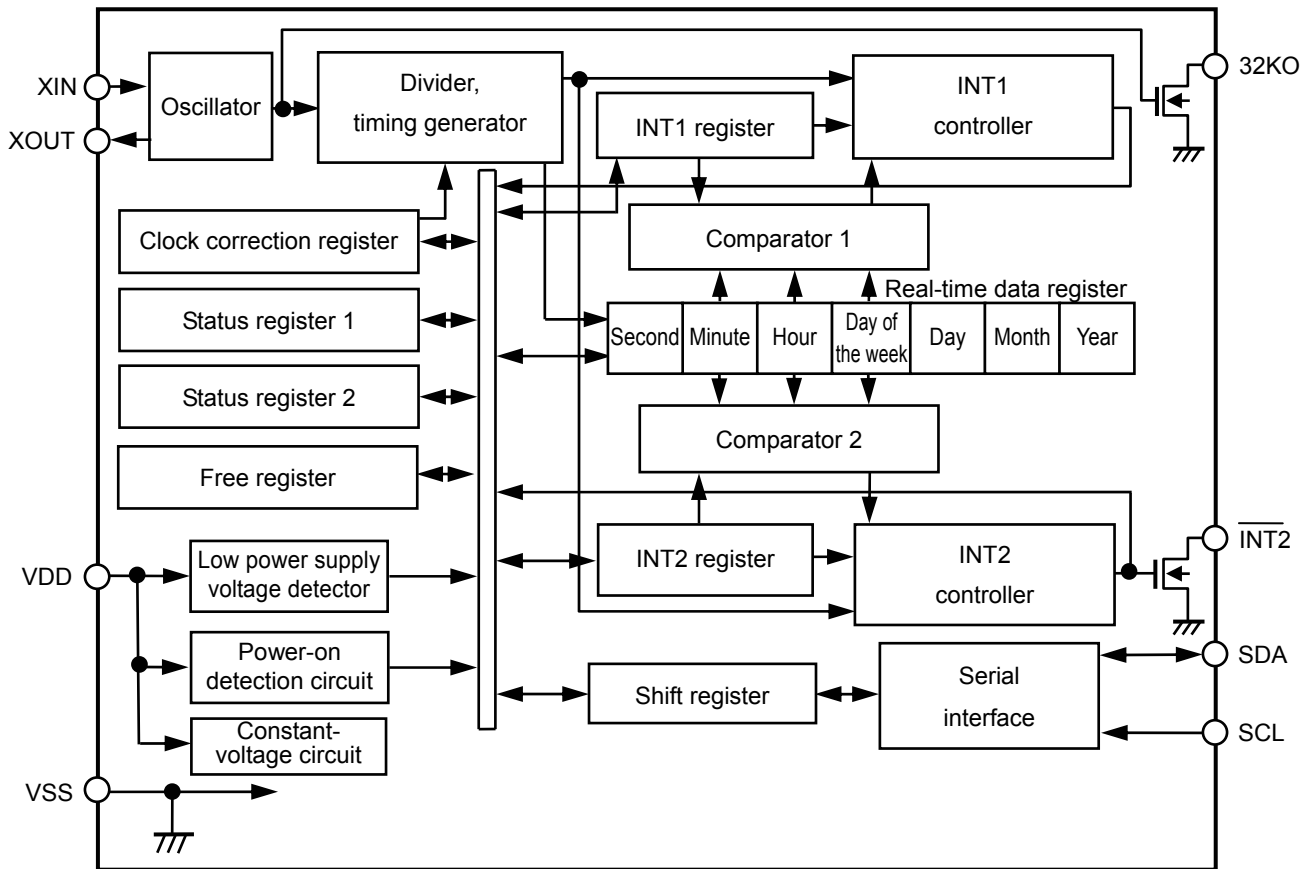
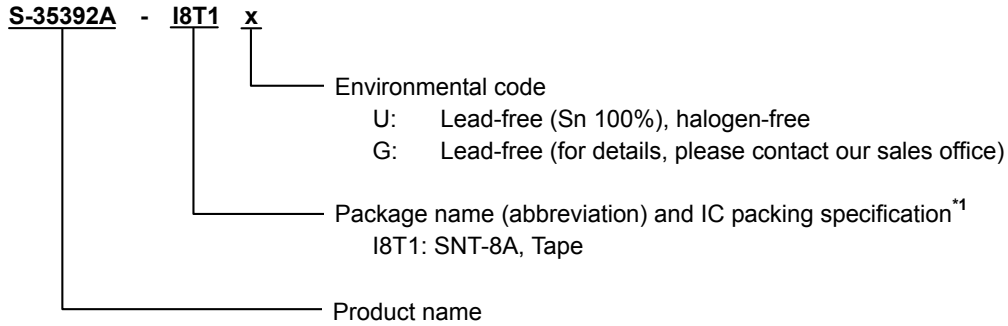

Figure 1

■ Product Name Structure

1. Product name



*1. Refer to the tape drawing.

2. Package

Table 1 Package Drawing Codes

Package Name	Dimension	Tape	Reel	Land
SNT-8A	PH008-A-P-SD	PH008-A-C-SD	PH008-A-R-SD	PH008-A-L-SD

■ **Pin Configuration**

1. **SNT-8A**

Table 2 List of Pins

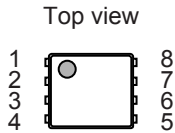

Figure 2 S-35392A-I8T1x

Pin No.	Symbol	Description	I/O	Configuration
1	32KO	Pin for constant output of 32.768 kHz	Output	Nch open-drain output (no protective diode at VDD)
2	XOUT	Connection pin for crystal oscillator	-	-
3	XIN			
4	VSS	GND pin	-	-
5	$\overline{\text{INT2}}$	Output pin for interrupt signal 2	Output	Nch open-drain output (no protective diode at VDD)
6	SCL	Input pin for serial clock	Input	CMOS input (no protective diode at VDD)
7	SDA	I/O pin for serial data	Bi-directional	Nch open-drain output (no protective diode at VDD) CMOS input
8	VDD	Pin for positive power supply	-	-

Remark 1. x: G or U

2. Please select products of environmental code = U for Sn 100%, halogen-free products.

■ Pin Functions

1. SDA (I/O for serial data) pin

This pin is a data input / output pin of I²C-bus interface. This pin inputs / outputs data by synchronizing with a clock pulse from the SCL pin. This pin has CMOS input and Nch open drain output. Generally in use, pull up this pin to the VDD potential via a resistor, and connect it to any other device having open drain or open collector output with wired-OR connection.

2. SCL (input for serial clock) pin

This pin is to input a clock pulse for I²C-bus interface. The SDA pin inputs / outputs data by synchronizing with the clock pulse.

3. XIN, XOUT (crystal oscillator connect) pin

Connect a crystal oscillator between XIN and XOUT.

4. 32KO (output of 32.768 kHz) pin

This is an output pin for 32.768 kHz. This pin constantly outputs a clock pulse after power-on.

5. INT2 (output for interrupt signal 2) pin

This pin outputs a signal of interrupt, or a clock pulse. By using the status register 2, users can select either of; alarm interrupt, output of user-set frequency, or minute-periodical interrupt 1. This pin has Nch open drain output.

6. VDD (positive power supply) pin

Connect this VDD pin with a positive power supply. Regarding the values of voltage to be applied, refer to "■ Recommended Operation Conditions".

7. VSS pin

Connect this VSS pin to GND.

■ Equivalent Circuits of Pins

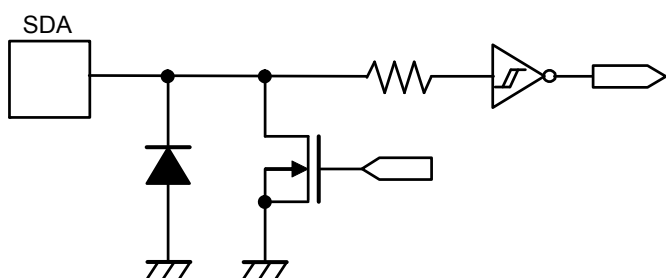

Figure 3 SDA Pin

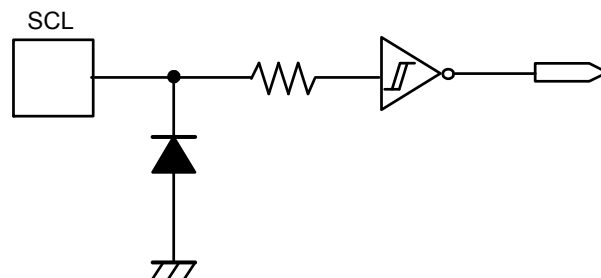

Figure 4 SCL Pin

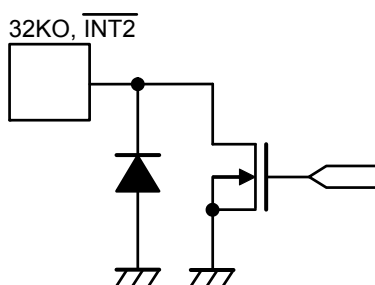

Figure 5 32KO Pin, INT2 Pin

■ **Absolute Maximum Ratings**

Table 3

Item	Symbol	Applied Pin	Absolute Maximum Rating	Unit
Power supply voltage	V _{DD}	–	V _{SS} – 0.3 to V _{SS} + 6.5	V
Input voltage	V _{IN}	SCL, SDA	V _{SS} – 0.3 to V _{SS} + 6.5	V
Output voltage	V _{OUT}	SDA, 32KO, $\overline{\text{INT2}}$	V _{SS} – 0.3 to V _{SS} + 6.5	V
Operating ambient temperature*1	T _{opr}	–	–40 to +85	°C
Storage temperature	T _{stg}	–	–55 to +125	°C

*1. Conditions with no condensation or frost. Condensation and frost cause short circuiting between pins, resulting in a malfunction.

Caution The absolute maximum ratings are rated values exceeding which the product could suffer physical damage. These values must therefore not be exceeded under any conditions.

■ **Recommended Operation Conditions**

Table 4

(V_{SS} = 0 V)

Item	Symbol	Condition	Min.	Typ.	Max.	Unit
Power supply voltage*1	V _{DD}	Ta = –40°C to +85°C	1.3	3.0	5.5	V
Time keeping power supply voltage*2	V _{DDT}	Ta = –40°C to +85°C	V _{DET} – 0.15	–	5.5	V
Crystal oscillator C _L value	C _L	–	–	6	7	pF

*1. The power supply voltage that allows communication under the conditions shown in **Table 9** of "■ **AC Electrical Characteristics**".

*2. The power supply voltage that allows time keeping. For the relationship with V_{DET} (low power supply voltage detection voltage), refer to "■ **Characteristics (Typical Data)**".

■ **Oscillation Characteristics**

Table 5

(Ta = +25°C, V_{DD} = 3.0 V, V_{SS} = 0 V, VT-200 crystal oscillator (C_L = 6 pF, 32.768 kHz) manufactured by Seiko Instruments Inc.)

Item	Symbol	Condition	Min.	Typ.	Max.	Unit
Oscillation start voltage	V _{STA}	Within 10 seconds	1.1	–	5.5	V
Oscillation start time	t _{STA}	–	–	–	1	s
IC-to-IC frequency deviation*1	δIC	–	–10	–	+10	ppm
Frequency voltage deviation	δV	V _{DD} = 1.3 V to 5.5 V	–3	–	+3	ppm/V
External capacitance	C _g	Applied to XIN pin	–	–	9.1	pF
Internal oscillation capacitance	C _d	Applied to XOUT pin	–	8	–	pF

*1. Reference value

■ DC Electrical Characteristics

Table 6 DC Characteristics ($V_{DD} = 3.0\text{ V}$)

($T_a = -40^\circ\text{C}$ to $+85^\circ\text{C}$, $V_{SS} = 0\text{ V}$, VT-200 crystal oscillator ($C_L = 6\text{ pF}$, 32.768 kHz , $C_g = 9.1\text{ pF}$) manufactured by Seiko Instruments Inc.)

Item	Symbol	Applied Pin	Condition	Min.	Typ.	Max.	Unit
Current consumption 1	I_{DD1}	–	Out of communication	–	0.45	1.13	μA
Current consumption 2	I_{DD2}	–	During communication (SCL = 100 kHz)	–	6	14	μA
Input current leakage 1	I_{IZH}	SCL, SDA	$V_{IN} = V_{DD}$	–0.5	–	0.5	μA
Input current leakage 2	I_{IZL}	SCL, SDA	$V_{IN} = V_{SS}$	–0.5	–	0.5	μA
Output current leakage 1	I_{OZH}	SDA, 32KO, $\overline{\text{INT2}}$	$V_{OUT} = V_{DD}$	–0.5	–	0.5	μA
Output current leakage 2	I_{OZL}	SDA, 32KO, $\overline{\text{INT2}}$	$V_{OUT} = V_{SS}$	–0.5	–	0.5	μA
Input voltage 1	V_{IH}	SCL, SDA	–	$0.8 \times V_{DD}$	–	$V_{SS} + 5.5$	V
Input voltage 2	V_{IL}	SCL, SDA	–	$V_{SS} - 0.3$	–	$0.2 \times V_{DD}$	V
Output current 1	I_{OL1}	32KO, $\overline{\text{INT2}}$	$V_{OUT} = 0.4\text{ V}$	3	5	–	mA
Output current 2	I_{OL2}	SDA	$V_{OUT} = 0.4\text{ V}$	5	10	–	mA
Power supply voltage detection voltage	V_{DET}	–	–	0.65	1	1.35	V

Table 7 DC Characteristics ($V_{DD} = 5.0\text{ V}$)

($T_a = -40^\circ\text{C}$ to $+85^\circ\text{C}$, $V_{SS} = 0\text{ V}$, VT-200 crystal oscillator ($C_L = 6\text{ pF}$, 32.768 kHz , $C_g = 9.1\text{ pF}$) manufactured by Seiko Instruments Inc.)

Item	Symbol	Applied Pin	Condition	Min.	Typ.	Max.	Unit
Current consumption 1	I_{DD1}	–	Out of communication	–	0.6	1.4	μA
Current consumption 2	I_{DD2}	–	During communication (SCL = 100 kHz)	–	14	30	μA
Input current leakage 1	I_{IZH}	SCL, SDA	$V_{IN} = V_{DD}$	–0.5	–	0.5	μA
Input current leakage 2	I_{IZL}	SCL, SDA	$V_{IN} = V_{SS}$	–0.5	–	0.5	μA
Output current leakage 1	I_{OZH}	SDA, 32KO, $\overline{\text{INT2}}$	$V_{OUT} = V_{DD}$	–0.5	–	0.5	μA
Output current leakage 2	I_{OZL}	SDA, 32KO, $\overline{\text{INT2}}$	$V_{OUT} = V_{SS}$	–0.5	–	0.5	μA
Input voltage 1	V_{IH}	SCL, SDA	–	$0.8 \times V_{DD}$	–	$V_{SS} + 5.5$	V
Input voltage 2	V_{IL}	SCL, SDA	–	$V_{SS} - 0.3$	–	$0.2 \times V_{DD}$	V
Output current 1	I_{OL1}	32KO, $\overline{\text{INT2}}$	$V_{OUT} = 0.4\text{ V}$	5	8	–	mA
Output current 2	I_{OL2}	SDA	$V_{OUT} = 0.4\text{ V}$	6	13	–	mA
Power supply voltage detection voltage	V_{DET}	–	–	0.65	1	1.35	V

■ AC Electrical Characteristics

Table 8 Measurement Conditions

Input pulse voltage	$V_{IH} = 0.9 \times V_{DD}, V_{IL} = 0.1 \times V_{DD}$
Input pulse rise / fall time	20 ns
Output determination voltage	$V_{OH} = 0.5 \times V_{DD}, V_{OL} = 0.5 \times V_{DD}$
Output load	100 pF + pull-up resistor 1 kΩ

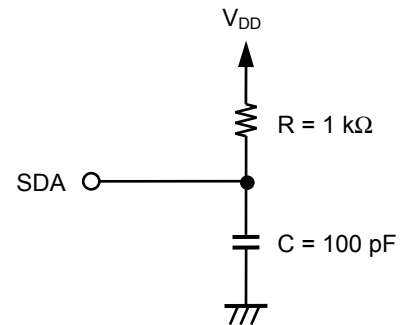

Remark The power supplies of the IC and load have the same electrical potential.

Figure 6 Output Load Circuit

Table 9 AC Electrical Characteristics

($T_a = -40^\circ\text{C}$ to $+85^\circ\text{C}$)

Item	Symbol	$V_{DD}^{*2} \geq 1.3\text{ V}$			$V_{DD}^{*2} \geq 3.0\text{ V}$			Unit
		Min.	Typ.	Max.	Min.	Typ.	Max.	
SCL clock frequency	f_{SCL}	0	–	100	0	–	400	kHz
SCL clock low time	t_{LOW}	4.7	–	–	1.3	–	–	μs
SCL clock high time	t_{HIGH}	4	–	–	0.6	–	–	μs
SDA output delay time ^{*1}	t_{PD}	–	–	3.5	–	–	0.9	μs
Start condition setup time	$t_{SU,STA}$	4.7	–	–	0.6	–	–	μs
Start condition hold time	$t_{HD,STA}$	4	–	–	0.6	–	–	μs
Data input setup time	$t_{SU,DAT}$	250	–	–	100	–	–	ns
Data input hold time	$t_{HD,DAT}$	0	–	–	0	–	–	μs
Stop condition setup time	$t_{SU,STO}$	4.7	–	–	0.6	–	–	μs
SCL, SDA rise time	t_R	–	–	1	–	–	0.3	μs
SCL, SDA fall time	t_F	–	–	0.3	–	–	0.3	μs
Bus release time	t_{BUF}	4.7	–	–	1.3	–	–	μs
Noise suppression time	t_i	–	–	100	–	–	50	ns

*1. Since the output format of the SDA pin is Nch open-drain output, SDA output delay time is determined by the values of the load resistance (R_L) and load capacity (C_L) outside the IC. Therefore, use this value only as a reference value.

*2. Regarding the power supply voltage, refer to "■ Recommended Operation Conditions".

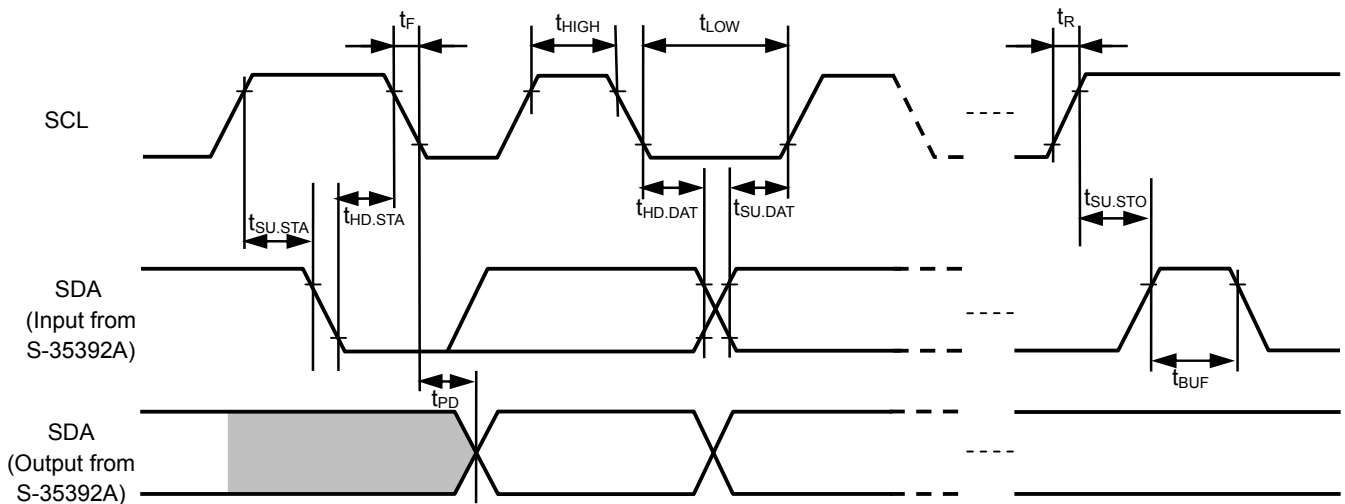

Figure 7 Bus Timing

■ Configuration of Data Communication

1. Data communication

For data communication, the master device in the system generates a start condition for the S-35392A. Next, the master device transmits 4-bit device code "0110", 3-bit command and 1-bit read / write command to the SDA line. After that, output or input is performed from B7 of data. If data I/O has been completed, finish communication by inputting a stop condition to the S-35392A. The master device generates an acknowledgment signal for every 1-byte. Regarding details, refer to "■ Serial Interface".

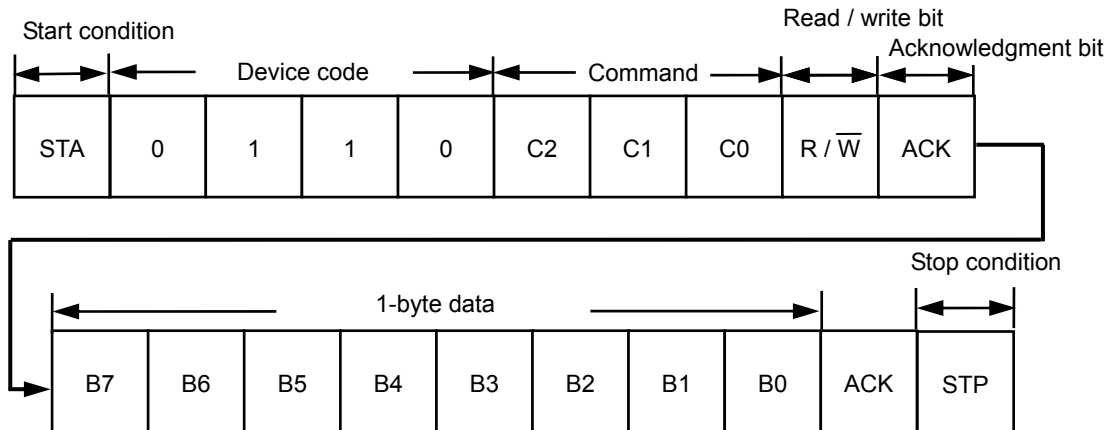

Figure 8 Data Communication

2. Configuration of command

8 types of command are available for the S-35392A. The S-35392A reads / writes the various registers by inputting these fixed codes and commands. The S-35392A does not perform any operation with any codes and commands other than those below.

Table 10 List of Commands

Device Code	Command			Data								
	C2	C1	C0	Description	B7	B6	B5	B4	B3	B2	B1	B0
0110	0	0	0	Status register 1 access	RESET* ¹	$\overline{12}/24$	SC0* ²	SC1* ²	INT1* ³	INT2* ³	BLD* ⁴	POC* ⁴
	0	0	1	Status register 2 access	INT1FE	INT1ME	INT1AE	SC2* ²	INT2FE	INT2ME	INT2AE	TEST* ⁵
	0	1	0	Real-time data 1 access (year data to)	Y1	Y2	Y4	Y8	Y10	Y20	Y40	Y80
					M1	M2	M4	M8	M10	_ ⁶	_ ⁶	_ ⁶
					D1	D2	D4	D8	D10	D20	_ ⁶	_ ⁶
					W1	W2	W4	_ ⁶	_ ⁶	_ ⁶	_ ⁶	_ ⁶
					H1	H2	H4	H8	H10	H20	AM/PM	_ ⁶
					m1	m2	m4	m8	m10	m20	m40	_ ⁶
	s1	s2	s4	s8	s10	s20	s40	_ ⁶				
	0	1	1	Real-time data 2 access (hour data to)	H1	H2	H4	H8	H10	H20	AM/PM	_ ⁶
					m1	m2	m4	m8	m10	m20	m40	_ ⁶
					s1	s2	s4	s8	s10	s20	s40	_ ⁶
1	0	0	INT1 register access (alarm time 1: week / hour / minute) (INT1AE = 1, INT1ME = 0, INT1FE = 0)	W1	W2	W4	_ ⁶	_ ⁶	_ ⁶	_ ⁶	A1WE	
			H1	H2	H4	H8	H10	H20	AM/PM	A1HE		
				m1	m2	m4	m8	m10	m20	m40	A1mE	
				INT1 register access (free register) (settings other than alarm time 1)	SC3* ²	SC4* ²	SC5* ²	SC6* ²	SC7* ²	SC8* ²	SC9* ²	SC10* ²
1	0	1	INT2 register access (alarm time 2: week / hour / minute) (INT2AE = 1, INT2ME = 0, INT2FE = 0)	W1	W2	W4	_ ⁶	_ ⁶	_ ⁶	_ ⁶	A2WE	
			H1	H2	H4	H8	H10	H20	AM/PM	A2HE		
				m1	m2	m4	m8	m10	m20	m40	A2mE	
				INT2 register access (output of user-set frequency) (INT2ME = 0, INT2FE = 1)	1 Hz	2 Hz	4 Hz	8 Hz	16 Hz	SC11* ²	SC12* ²	SC13* ²
1	1	0	Clock correction register access	V0	V1	V2	V3	V4	V5	V6	V7	
1	1	1	Free register access	F0	F1	F2	F3	F4	F5	F6	F7	

- *1. Write-only flag. The S-35392A initializes by writing "1" in this register.
- *2. Scratch bit. This is a register which is available for read / write operations and can be used by users freely.
- *3. Read-only flag. Valid only when using the alarm function. When the alarm time matches, this flag is set to "1", and it is cleared to "0" when reading.
- *4. Read-only flag. "POC" is set to "1" when power is applied. It is cleared to "0" when reading. Regarding "BLD", refer to "■ Low Power Supply Voltage Detection Circuit".
- *5. Test bit for SII. Be sure to set to "0" in use.
- *6. No effect when writing. It is "0" when reading.

■ Configuration of Registers

1. Real-time data register

The real-time data register is a 7-byte register that stores the data of year, month, day, day of the week, hour, minute, and second in the BCD code. To write / read real-time data 1 access, transmit / receive the data of year in B7, month, day, day of the week, hour, minute, second in B0, in 7-byte. When you skip the procedure to access the data of year, month, day, day of the week, read / write real-time data 2 accesses. In this case, transmit / receive the data of hour in B7, minute, second in B0, in 3-byte.

The S-35392A transfers a set of data of time to the real-time data register when it recognizes the read command. Therefore, the S-35392A keeps precise time even if time-carry occurs during the read operation of real-time data register.

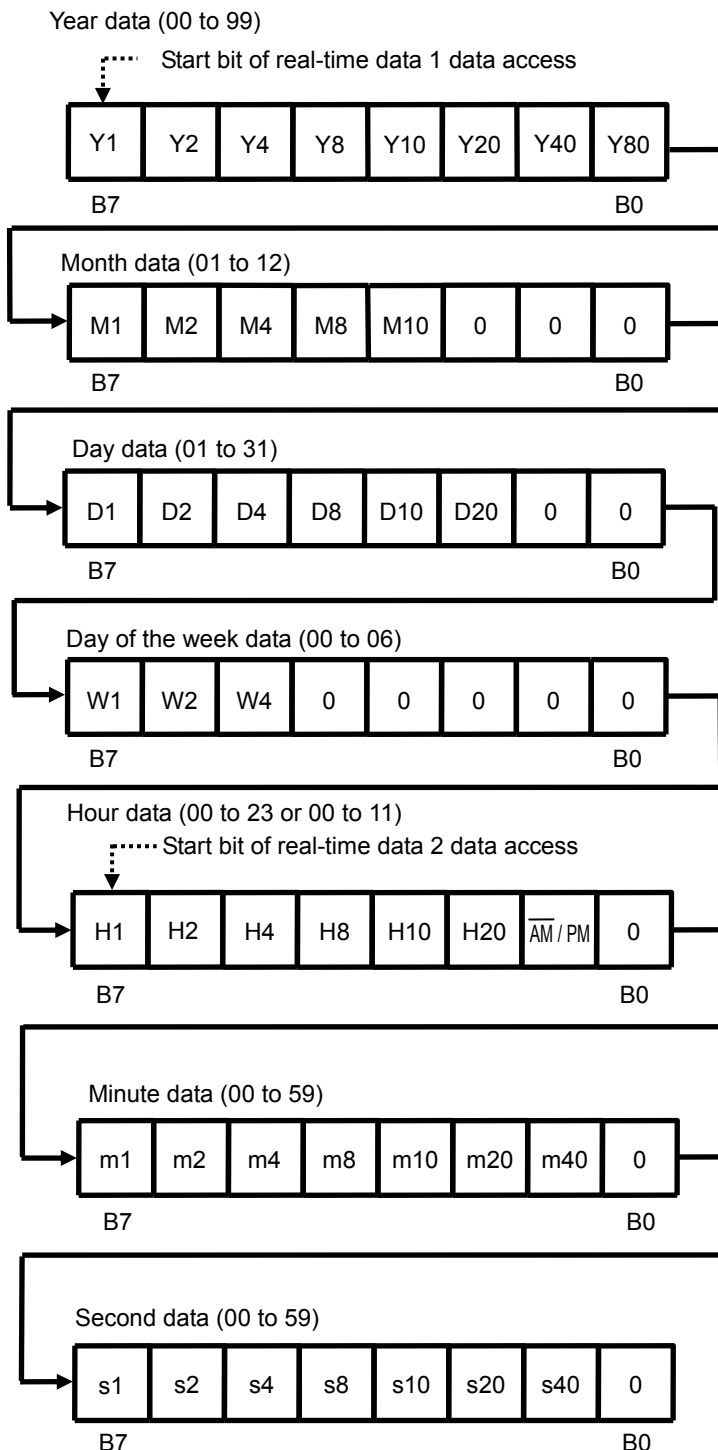

Figure 9 Real-Time Data Register
Seiko Instruments Inc.

Year data (00 to 99): Y1, Y2, Y4, Y8, Y10, Y20, Y40, Y80

Sets the lower two digits of the Western calendar year (00 to 99) and links together with the auto calendar function until 2099.

Example: 2053 (Y1, Y2, Y4, Y8, Y10, Y20, Y40, Y80) = (1, 1, 0, 0, 1, 0, 1, 0)

Month data (01 to 12): M1, M2, M4, M8, M10

Example: December (M1, M2, M4, M8, M10, 0, 0, 0) = (0, 1, 0, 0, 1, 0, 0, 0)

Day data (01 to 31): D1, D2, D4, D8, D10, D20

The count value is automatically changed by the auto calendar function.

1 to 31: Jan., Mar., May, July, Aug., Oct., Dec., 1 to 30: April, June, Sep., Nov.

1 to 29: Feb. (leap year), 1 to 28: Feb. (non-leap year)

Example: 29 (D1, D2, D4, D8, D10, D20, 0, 0) = (1, 0, 0, 1, 0, 1, 0, 0)

Day of the week data (00 to 06): W1, W2, W4

A septenary up counter. Day of the week is counted in the order of 00, 01, 02, ..., 06, and 00. Set up day of the week and the count value.

Hour data (00 to 23 or 00 to 11): H1, H2, H4, H8, H10, H20, $\overline{\text{AM}} / \text{PM}$

In 12-hour mode, write 0; AM, 1; PM in the $\overline{\text{AM}} / \text{PM}$ bit. In 24-hour mode, users can write either 0 or 1. 0 is read when the hour data is from 00 to 11, and 1 is read when from 12 to 23.

Example (12-hour mode): 11 p.m. (H1, H2, H4, H8, H10, H20, $\overline{\text{AM}} / \text{PM}$, 0) = (1, 0, 0, 0, 1, 0, 1, 0)

Example (24-hour mode): 22 (H1, H2, H4, H8, H10, H20, $\overline{\text{AM}} / \text{PM}$, 0) = (0, 1, 0, 0, 0, 1, 1, 0)

Minute data (00 to 59): m1, m2, m4, m8, m10, m20, m40

Example: 32 minutes (m1, m2, m4, m8, m10, m20, m40, 0) = (0, 1, 0, 0, 1, 1, 0, 0)

Example: 55 minutes (m1, m2, m4, m8, m10, m20, m40, 0) = (1, 0, 1, 0, 1, 0, 1, 0)

Second data (00 to 59): s1, s2, s4, s8, s10, s20, s40

Example: 19 seconds (s1, s2, s4, s8, s10, s20, s40, 0) = (1, 0, 0, 1, 1, 0, 0, 0)

2. Status register 1

Status register 1 is a 1-byte register that is used to display and set various modes. The bit configuration is shown below.

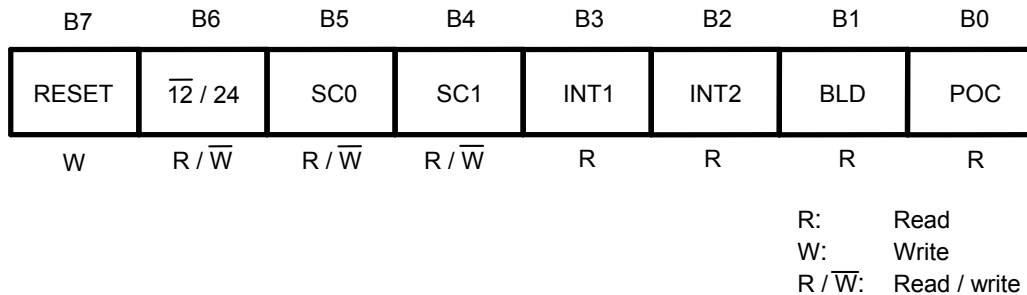

Figure 10 Status Register 1

B0: POC

This flag is used to confirm whether the power is on. The power-on detection circuit operates at power-on and B0 is set to "1". This flag is read-only. Once it is read, it is automatically set to "0". When this flag is "1", be sure to initialize. Regarding the operation after power-on, refer to "■ Power-on Detection Circuit and Register Status".

B1: BLD

This flag is set to "1" when the power supply voltage decreases to the level of detection voltage (V_{DET}) or less. Users can detect a drop in the power supply voltage. This flag is set to "1" once, it is not set to "0" again even if the power supply increases to the level of detection voltage (V_{DET}) or more. This flag is read-only. When this flag is "1", be sure to initialize. Regarding the operation of the power supply voltage detection circuit, refer to "■ Low Power Supply Voltage Detection Circuit".

B2: INT2, B3: INT1

This flag indicates the time set by alarm and when the time has reached it. This flag is set to "1" when the time that users set by using the alarm function has come. The INT1 flag in the alarm 1 function and the INT2 flag at alarm 2 interrupt mode are set to "0". Set "0" in INT1AE (B5 in the status register 2) or in INT2AE (B1 in the status register 2) after reading "1" in the INT1 flag or in the INT2 flag. This flag is read-only. This flag is read once, it is set to "0" automatically.

B4: SC1, B5: SC0

These flags are SRAM type registers, they are 2 bits as a whole, can be freely set by users.

B6: $\overline{12}/24$

This flag is used to set 12-hour or 24-hour mode. Set the flag ahead of write operation of the real-time data register in case of 24-hour mode.

- 0: 12-hour mode
- 1: 24-hour mode

B7: RESET

The internal IC is initialized by setting this bit to "1". This bit is write-only. It is always "0" when reading. When applying the power supply voltage to the IC, be sure to write "1" to this bit to initialize the circuit. Regarding each status of data after initialization, refer to "■ Register Status After Initialization".

3. Status register 2

Status register 2 is a 1-byte register that is used to display and set various modes. The bit configuration is shown below.

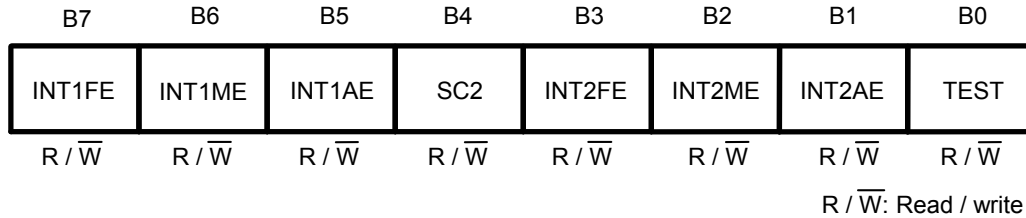

Figure 11 Status Register 2

B0: TEST

This is a test flag for SII. Be sure to set this flag to "0" in use. If this flag is set to "1", be sure to initialize to set to "0".

B1: INT2AE, B2: INT2ME, B3: INT2FE

These bits are used to select the output mode for the $\overline{\text{INT2}}$ pin. **Table 11** shows how to select the mode. To use alarm 2 interrupt, access the INT2 register after setting the alarm interrupt mode.

Table 11 Output Modes for $\overline{\text{INT2}}$ Pin

INT2AE	INT2ME	INT2FE	$\overline{\text{INT2}}$ Pin Output Mode
0	0	0	No interrupt
$\bar{*}$ 1	0	1	Output of user-set frequency
$\bar{*}$ 1	1	0	Per-minute edge interrupt
$\bar{*}$ 1	1	1	Minute-periodical interrupt 1 (50% duty)
1	0	0	Alarm 2 interrupt

*1. Don't care (both of 0 and 1 are acceptable).

B4: SC2

This is an SRAM type register that can be freely set by users.

B5: INT1AE, B6: INT1ME, B7: INT1FE

To use the alarm 1 function, access the INT register 1 after setting INT1AE = "1", INT1ME = "0", and INT1FE = "0". In other settings than this, these flags are disable for setting the alarm time (free registers).

4. INT1 register and INT2 register

The INT1 register is to set up the alarm time. The INT2 register is to set up the output of user-set frequency or alarm interrupt. To switch the output mode, use the status register 2.

The INT1 register works as an alarm-time data register in the alarm 1 interrupt mode selected by users. The INT1 flag (B3 in the status register 1) displays the alarm time when it matches.

The INT2 register works as an alarm-time data register in the alarm interrupt mode selected by using the status register 2. In the mode output of user-set frequency, the INT2 register works as a data register to set up the frequency for output clock. Clock pulse and output of alarm interrupt are output from the INT2 pin. And the INT2 flag (B2 in the status register 1) displays the alarm time when it matches.

4.1 Alarm interrupt

Users can set the alarm time (the data of day of the week, hour, minute) by using the INT1 and INT2 registers which are 3-byte data registers. The configuration of register is as well as the data register of day of the week, hour, minute, in the real-time data register; is expressed by the BCD code. Do not set a nonexistent day. Users are necessary to set up the alarm-time data according to the 12 / 24 hour mode that they set by using the status register 1.

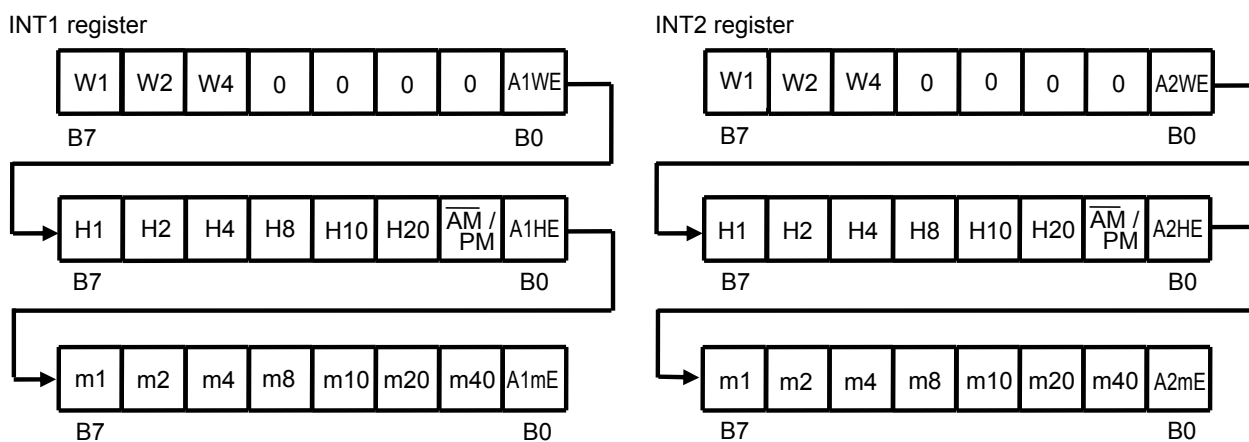

Figure 12 INT1 Register and INT2 Register (Alarm-Time Data)

The INT1 register has A1WE, A1HE, A1mE at B0 in each byte. It is possible to make data valid; the data of day of the week, hour, minute which are in the corresponded byte; by setting these bits to "1". This is as well in A2WE, A2HE, A2mE in the INT2 register.

Setting example: alarm time "7:00 pm" in the INT1 register

(1) 12-hour mode (status register 1 B6 = 0)

set up 7:00 PM

Data written to INT1 register

Day of the week	*1	*1	*1	*1	*1	*1	*1	0
Hour	1	1	1	0	0	0	1	1
Minute	0	0	0	0	0	0	0	1
	B7							B0

*1. Don't care (both of 0 and 1 are acceptable).

(2) 24-hour mode (status register 1 B6 = 1)

set up 19:00 PM

Data written to INT1 register

Day of the week	*1	*1	*1	*1	*1	*1	*1	0
Hour	1	0	0	1	1	0	1 ^{*2}	1
Minute	0	0	0	0	0	0	0	1
	B7							B0

*1. Don't care (both of 0 and 1 are acceptable).

*2. Set up the AM / PM flag along with the time setting.

4.2 Free register (INT1 register)

The INT1 register is a 1-byte SRAM type register that can be set freely by users.

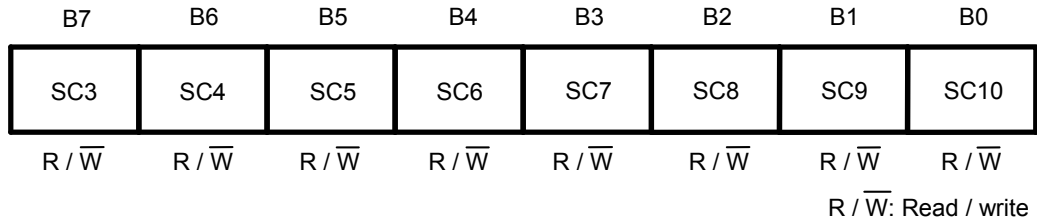

Figure 13 INT1 Register (Free Register)

4.3 Output of user-set frequency (INT2 register)

The INT2 register is a 1-byte data register to set up the output frequency. Setting each bit B7 to B3 in the register to "1", the frequency which corresponds to the bit is output in the AND-form. SC11 to SC13 in the INT2 register are 3-bit SRAM type registers that can be freely set by users.

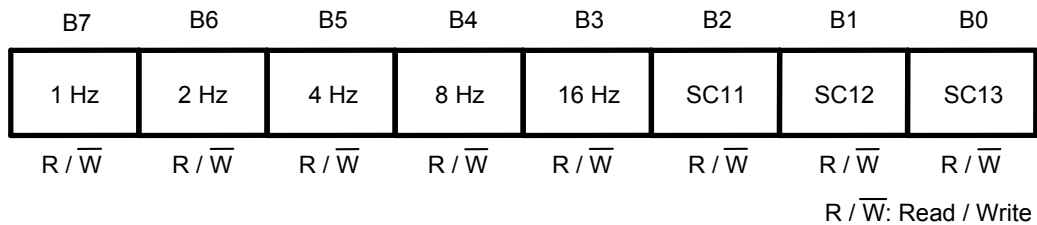

Figure 14 INT2 Register (Data Register for Output Frequency)

Example: B7 to B3 = 50h

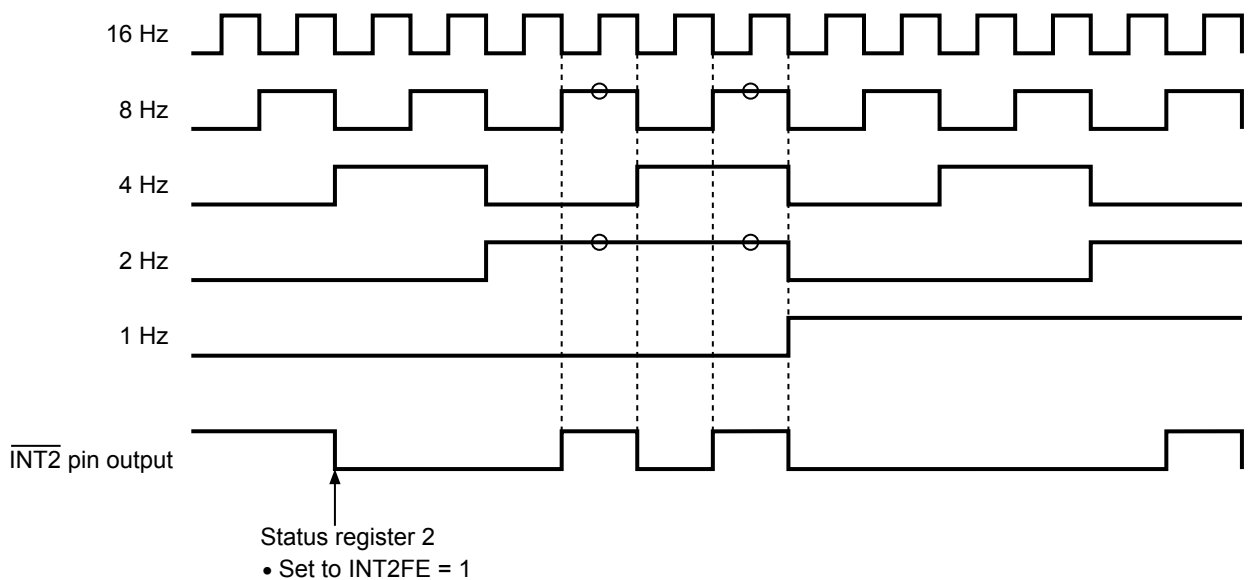

Figure 15 Example of Output from INT2 Register (Data Register for Output Frequency)

1 Hz clock output is synchronized with second-counter of the S-35392A.

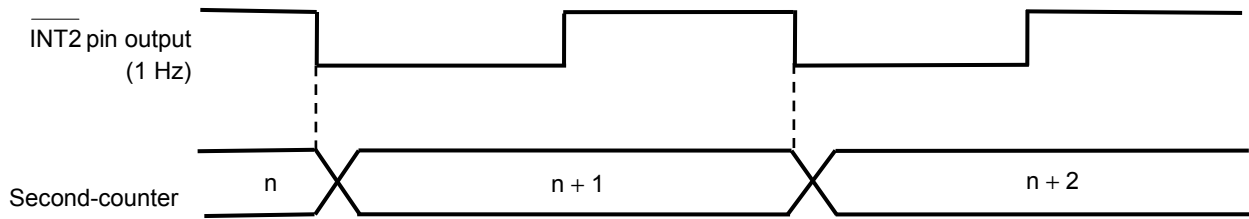

Figure 16 1 Hz Clock Output and Second-counter

5. Clock correction register

The clock correction register is a 1-byte register that is used to correct advance / delay of the clock. When not using this function, set this register to "00h". Regarding the register values, refer to "■ Function of Clock Correction".

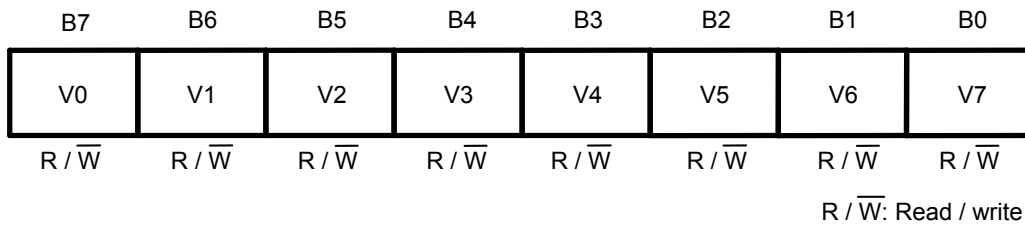

Figure 17 Clock Correction Register

6. Free register

The free register is a 1-byte SRAM type register that can be set freely by users.

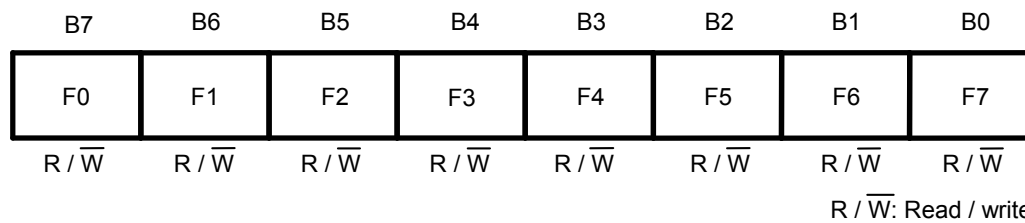

Figure 18 Free Register

■ Power-on Detection Circuit and Register Status

The power-on detection circuit operates by power-on the S-35392A, as a result each register is cleared; each register is set as follows.

Real-time data register:	00 (Y), 01 (M), 01 (D), 0 (day of the week), 00 (H), 00 (M), 00 (S)
Status register 1:	"01h"
Status register 2:	"80h"
INT1 register:	"80h"
INT2 register:	"00h"
Clock correction register:	"00h"
Free register:	"00h"

"1" is set in the POC flag (B0 in the status register 1) to indicate that power has been applied. In this case, be sure to initialize. The POC flag is set to "0" due to initialization (Refer to "■ Register Status After Initialization").

For the regular operation of power-on detection circuit, as seen in **Figure 19**, the period to power-up the S-35392A is that the voltage reaches 1.3 V within 10 ms after setting the IC's power supply voltage at 0 V. When the POC flag (B0 in the status register 1) is not in "1", in this case, power-on the S-35392A once again.

Moreover, regarding the processing right after power-on, refer to "■ Flowchart of Initialization and Example of Real-time Data Set-up".

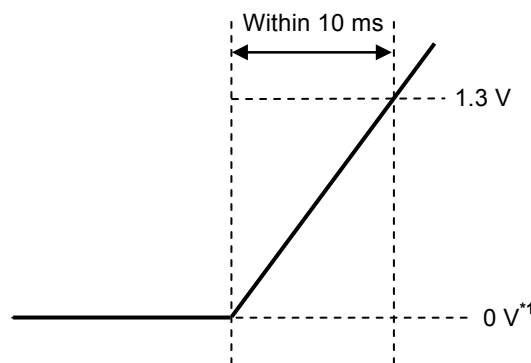

*1. 0 V indicates that there are no potential differences between the VDD pin and VSS pin of the S-35392A.

Figure 19 How to Raise the Power Supply Voltage

■ Register Status After Initialization

The status of each register after initialization is as follows.

Real-time data register: 00 (Y), 01 (M), 01 (D), 0 (day of the week), 00 (H), 00 (M), 00 (S)
 Status register 1: "0 B6 B5 B4 0 0 0 0 b"
 (In B6, B5, B4, the data of B6, B5, B4 in the status register 1 at initialization is set. Refer to Figure 20.)
 Status register 2: "00h"
 INT1 register: "00h"
 INT2 register: "00h"
 Clock correction register: "00h"
 Free register: "00h"

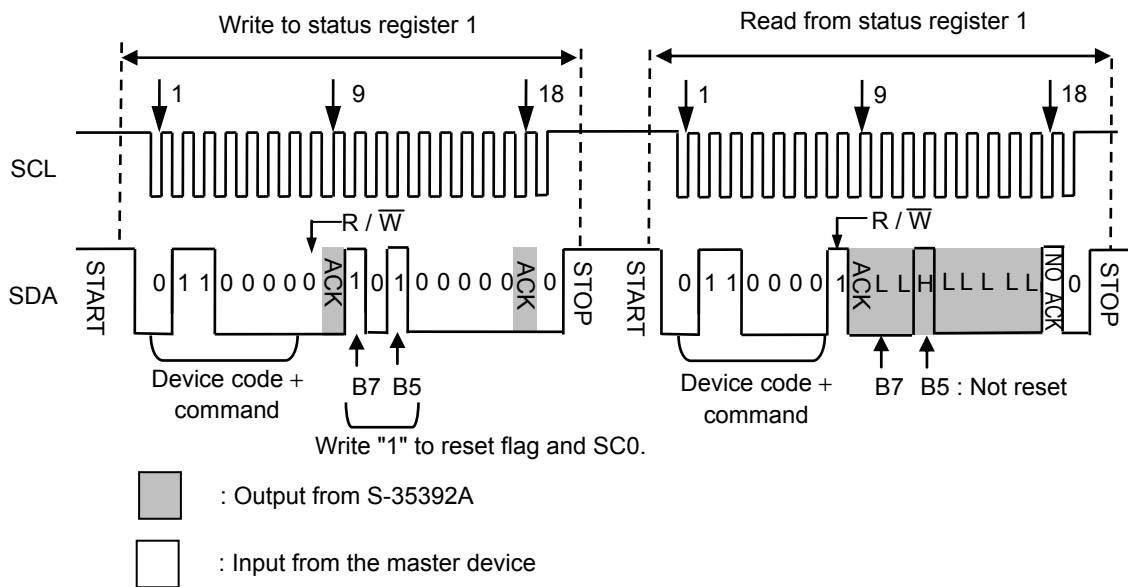

Figure 20 Data of Status Register 1 at Initialization

■ Low Power Supply Voltage Detection Circuit

The S-35392A has a low power supply voltage detection circuit, so that users can monitor drops in the power supply voltage by reading the BLD flag (B1 in the status register 1). There is a hysteresis width of approx. 0.15 V typ. between detection voltage and release voltage (refer to "■ Characteristics (Typical Data)"). The low power supply voltage detection circuit does the sampling operation only once in one sec for 15.6 ms.

If the power supply voltage decreases to the level of detection voltage (V_{DET}) or less, "1" is set to the BLD flag so that sampling operation stops. Once "1" is detected in the BLD flag, no sampling operation is performed even if the power supply voltage increases to the level of release voltage or more, and "1" is held in the BLD flag.

Furthermore, the S-35392A does not initialize the internal circuit even if "1" is set to the BLD flag. If the BLD flag is "1" even after the power supply voltage is recovered, the internal circuit may be in the indefinite status. In this case, be sure to initialize the circuit. Without initializing, if the next BLD flag reading is done after sampling, the BLD flag gets reset to "0". In this case, be sure to initialize although the BLD flag is in "0" because the internal circuit may be in the indefinite status.

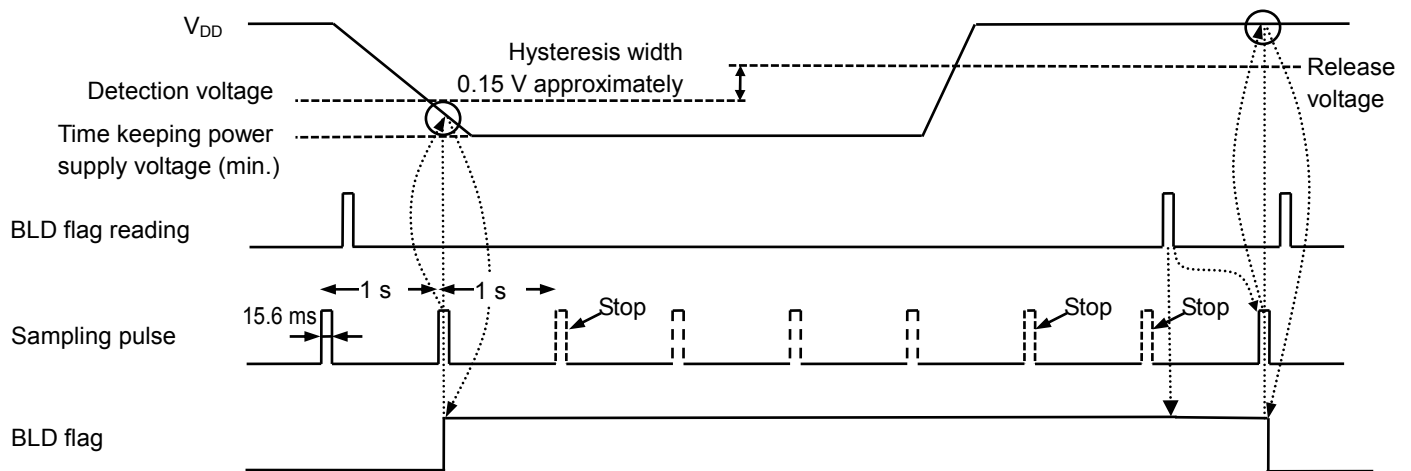

Figure 21 Timing of Low Power Supply Voltage Detection Circuit

■ Circuits Power-on and Low Power Supply Voltage Detection

Figure 22 shows the changes of the POC flag and BLD flag due to V_{DD} fluctuation.

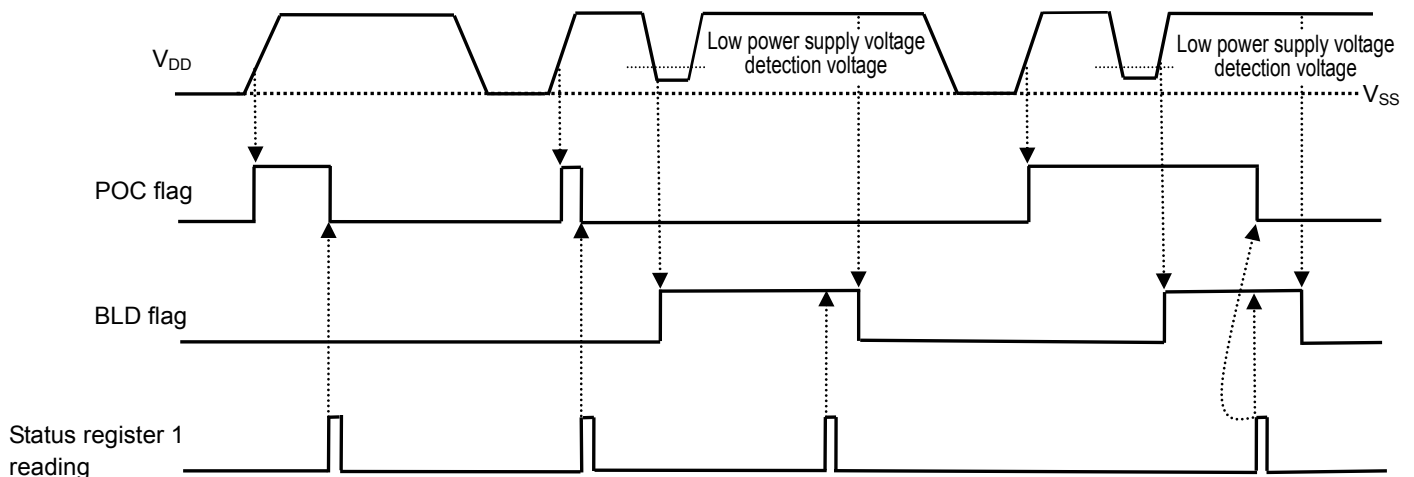

Figure 22 POC Flag and BLD Flag

■ Correction of Nonexistent Data and End-of-Month

When users write the real-time data, the S-35392A checks it. In case that the data is invalid, the S-35392A does the following procedures.

1. Processing of nonexistent data

Table 12 Processing of Nonexistent Data

Register	Normal Data	Nonexistent Data	Result
Year data	00 to 99	XA to XF, AX to FX	00
Month data	01 to 12	00, 13 to 19, XA to XF	01
Day data	01 to 31	00, 32 to 39, XA to XF	01
Day of the week data	0 to 6	7	0
Hour data *1	24-hour	0 to 23	24 to 29, 3X, XA to XF
	12-hour	0 to 11	12 to 20, XA to XF
Minute data	00 to 59	60 to 79, XA to XF	00
Second data *2	00 to 59	60 to 79, XA to XF	00

*1. In 12-hour mode, write the $\overline{\text{AM}} / \text{PM}$ flag (B1 in hour data in the real-time data register).

In 24-hour mode, the $\overline{\text{AM}} / \text{PM}$ flag in the real-time data register is omitted. However in the flag of reading, users are able to read 0; 0 to 11, 1; 12 to 23.

*2. Processing of nonexistent data, regarding second data, is done by a carry pulse which is generated in 1 second, after writing. At this point the carry pulse is sent to the minute-counter.

2. Correction of end-of-month

A nonexistent day, such as February 30 and April 31, is set to the first day of the next month.

Alarm 1 Function and $\overline{\text{INT2}}$ Pin Output Mode

In the output mode for $\overline{\text{INT2}}$ pin, users are able to select the output; alarm 2 interrupt, user-set frequency, per-minute edge interrupt, minute-periodical interrupt. To switch the output mode for $\overline{\text{INT2}}$ pin and the alarm 1 function, use the status register 2. Refer to "3. Status register 2" in "Configuration of Registers".

When switching the output mode for $\overline{\text{INT2}}$ pin, be careful of the output status of the pin. Especially, when using alarm 2 interrupt output, or the output of user-set frequency, switch the output mode after setting "00h" in the INT2 register. In per-minute edge interrupt output / minute-periodical interrupt output, it is unnecessary to set data in the INT2 register for users.

Refer to the followings regarding each operation of output modes.

1. Alarm 1 function and alarm 2 interrupt

Alarm 2 interrupt output is the function to set the INT2 flag "H" by the output "L" from the $\overline{\text{INT2}}$ pin, at the alarm time which is set by user has come. If setting the pin output to "H", turn off the alarm function by setting "0" in INT2AE in the status register 2.

By reading, the INT2 flag is once cleared automatically. In the alarm 1 function, the INT1 flag (B3 in the status register 1) is set to "H" when the set time has come. The INT1 flag is also cleared once by reading.

In the alarm 1 function, set the data of day of the week, hour, minute of the alarm time in the INT1 register. In alarm 2 interrupt, set in the INT2 register. Refer to "4. INT1 register and INT2 register" in "Configuration of Registers".

1.1 Alarm setting of "W (day of the week), H (hour), m (minute)"

Status register 2 setting

- Alarm 1 function
INT1ME = INT1FE = 0
- Alarm 2 interrupt
INT2ME = INT2FE = 0

INTx register alarm enable flag

- AxHE = AxmE = AxWE = "1"

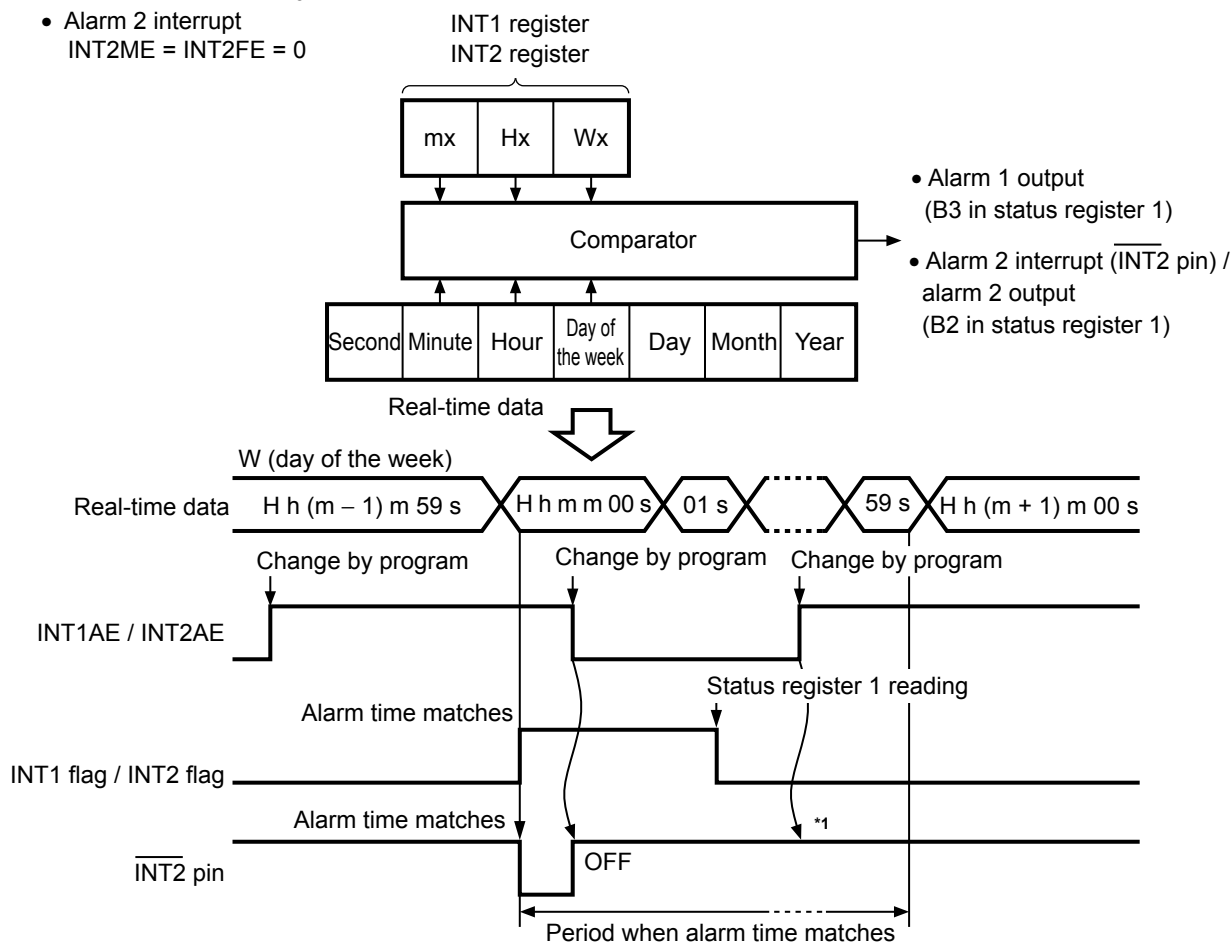

*1. If users clear INT2AE once; "L" is not output from the $\overline{\text{INT2}}$ pin by setting INT2AE enable again, within a period when the alarm time matches real-time data.

Figure 23 Alarm Interrupt Output Timing
Seiko Instruments Inc.

1.2 Alarm setting of "H (hour)"

- Status register 2 setting
- Alarm 1 function
INT1ME = INT1FE = 0
 - Alarm 2 interrupt
INT2ME = INT2FE = 0

- INTx register alarm enable flag
- AxmE = AxWE = "0", AxHE = "1"

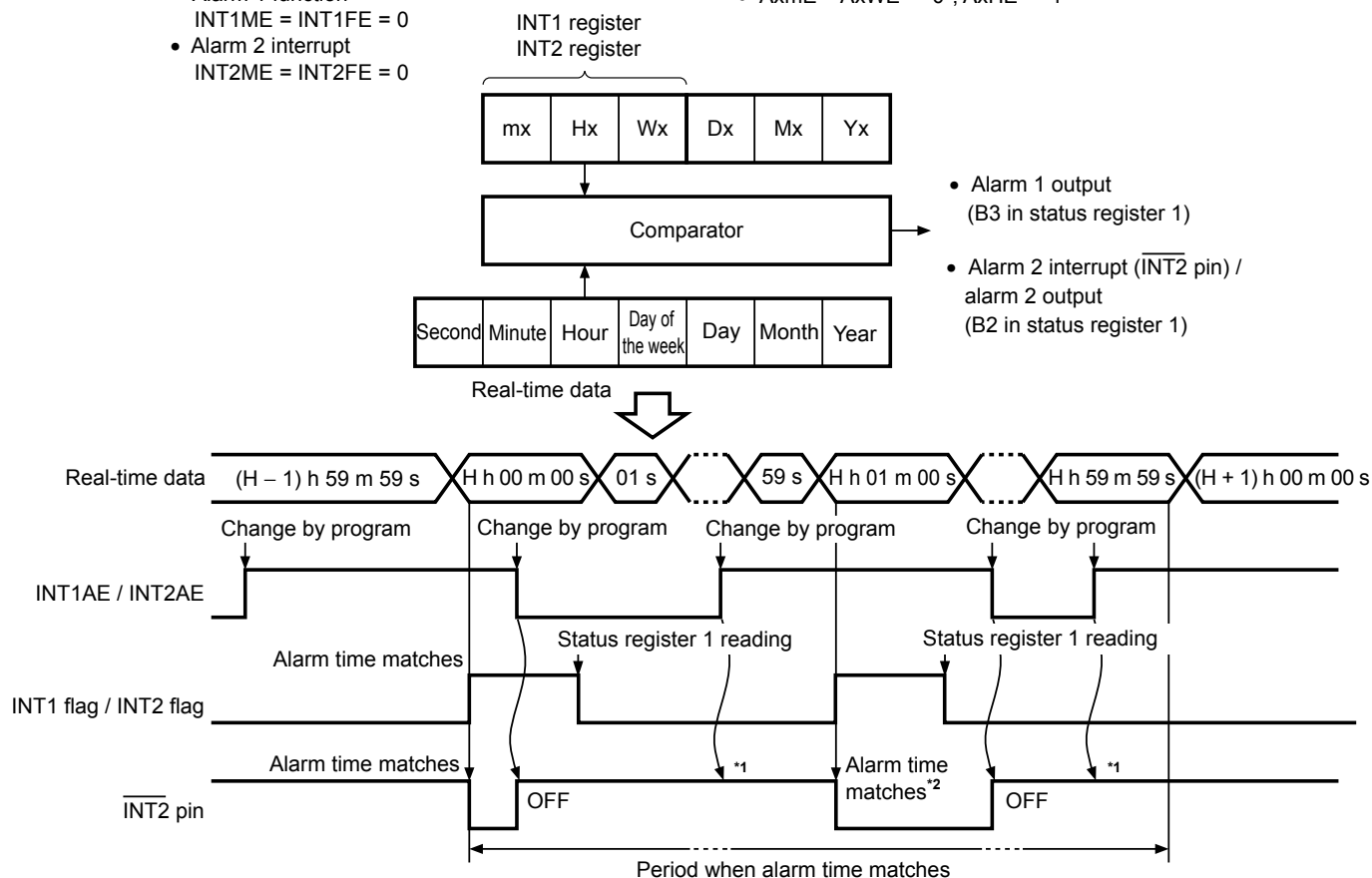

- *1. If users clear INT2AE once; "L" is not output from the $\overline{\text{INT2}}$ pin by setting INT2AE enable again, within a period when the alarm time matches real-time data.
- *2. If turning the alarm output on by changing the program, within the period when the alarm time matches real-time data, "L" is output again from the $\overline{\text{INT2}}$ pin when the minute is counted up.

Figure 24 Alarm Interrupt Output Timing

2. Output of user-set frequency

The output of user-set frequency is the function to output the frequency which is selected by using data, from the $\overline{\text{INT2}}$ pin, in the AND-form. Set up the data of frequency in the INT2 register.

Refer to "4. INT1 register and INT2 register" in "■ Configuration of Registers".

- Status register 2 setting
- INT2 pin output mode
INT2AE = Don't care (0 or 1), INT2ME = 0

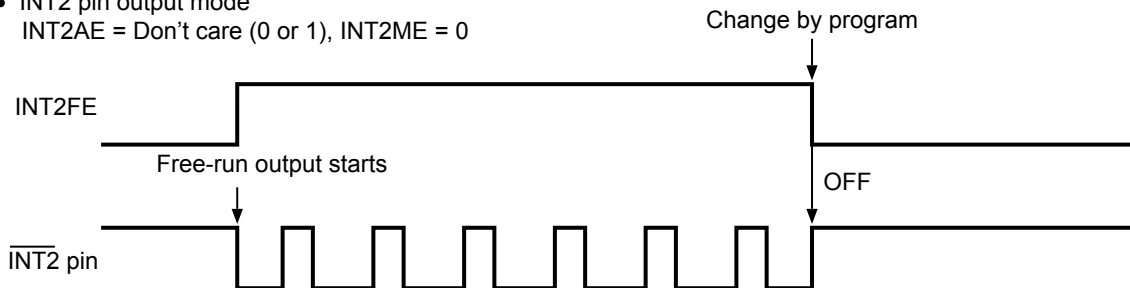

Figure 25 Output Timing of User-set Frequency

3. Per-minute edge interrupt output

Per-minute edge interrupt output is the function to output "L" from the $\overline{\text{INT2}}$ pin, when the first minute-carry processing is done, after selecting the output mode.

To set the pin output to "H", in the $\overline{\text{INT2}}$ pin output mode, input "0" in INT2ME in the status register 2 in order to turn off this mode.

Status register 2 setting

- $\overline{\text{INT2}}$ pin output mode
 INT2AE = Don't care (0 or 1), INT2FE = 0

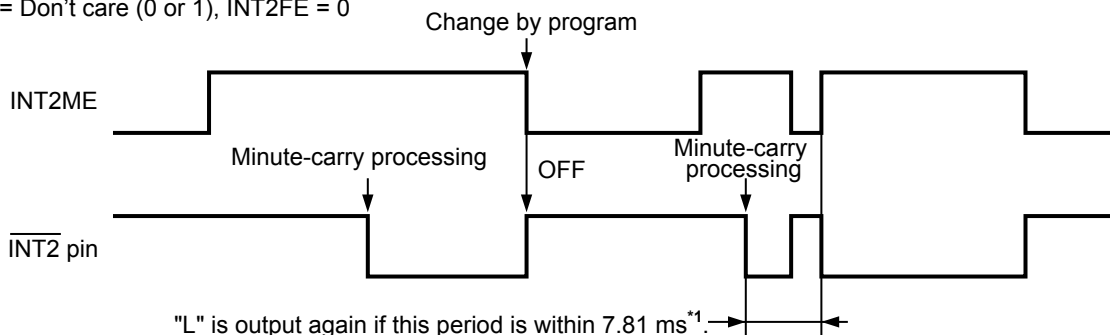

*1. Pin output is set to "H" by disabling the output mode within 7.81 ms, because the signal of this procedure is maintained for 7.81 ms. Note that pin output is set to "L" by setting enable the output mode again.

Figure 26 Timing of Per-minute Edge Interrupt Output

4. Minute-periodical interrupt output 1

The minute-periodical interrupt 1 is the function to output the one-minute clock pulse (Duty 50%) from the $\overline{\text{INT2}}$ pin, when the first minute-carry processing is done, after selecting the output mode.

Status register 2 setting

- $\overline{\text{INT2}}$ pin output mode
 INT2AE = 0

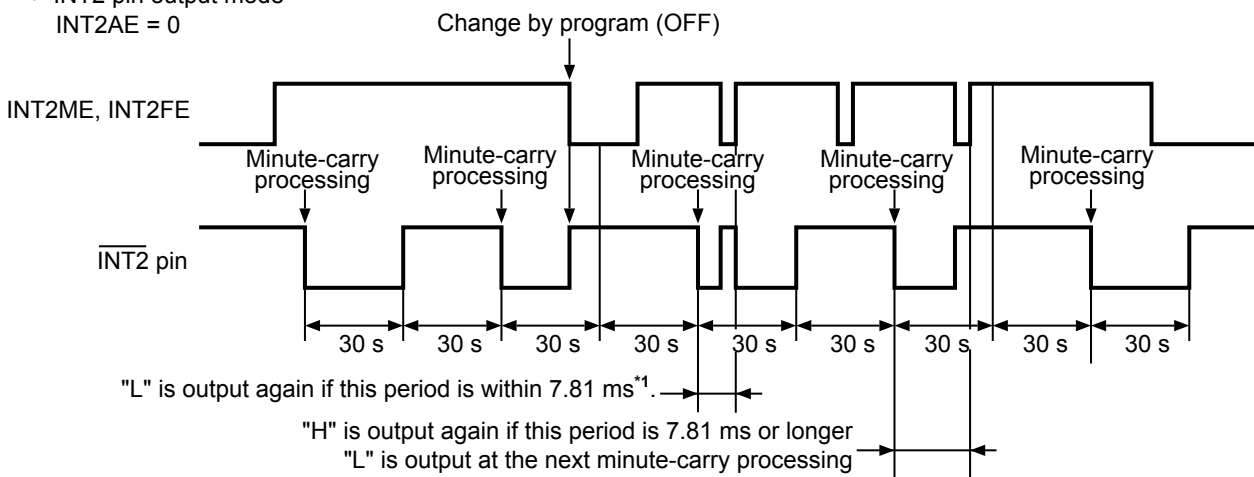

*1. Setting the output mode disable makes the pin output "H", while the output from the $\overline{\text{INT2}}$ pin is in "L". Note that pin output is set to "L" by setting enable the output mode again.

Figure 27 Timing of Minute-periodical Interrupt Output 1

■ Function of Clock Correction

The function of clock correction is to correct advance / delay of the clock due to the deviation of oscillation frequency, in order to make a high precise clock. For correction, the S-35392A adjusts the clock pulse by using a certain part of the dividing circuit, not adjusting the frequency of the crystal oscillator. Correction is performed once every 20 seconds (or 60 seconds). The minimum resolution is approx. 3 ppm (or approx. 1 ppm) and the S-35392A corrects in the range of -195.3 ppm to +192.2 ppm (or of -65.1 ppm to +64.1 ppm) (Refer to **Table 13**). Users can set up this function by using the clock correction register. Regarding how to calculate the setting data, refer to "1. How to calculate". When not using this function, be sure to set "00h".

Table 13 Function of Clock Correction

Item	B0 = 0	B0 = 1
Correction	Every 20 seconds	Every 60 seconds
Minimum resolution	3.052 ppm	1.017 ppm
Correction range	-195.3 ppm to +192.2 ppm	-65.1 ppm to +64.1 ppm

1. How to calculate

1.1 If current oscillation frequency > target frequency (in case the clock is fast)

$$\text{Correction value}^{*1} = 128 - \text{Integral value} \left(\frac{(\text{Current oscillation frequency actual measurement value}^{*2}) - (\text{Target oscillation frequency}^{*3})}{(\text{Current oscillation frequency actual measurement value}^{*2}) \times (\text{Minimum resolution}^{*4})} \right)$$

Caution The figure range which can be corrected is that the calculated value is from 0 to 64.

- *1. Convert this value to be set in the clock correction register. For how to convert, refer to "(1) Calculation example 1".
- *2. Measurement value when 1 Hz clock pulse is output from the $\overline{\text{INT2}}$ pin.
- *3. Target value of average frequency when the clock correction function is used.
- *4. Refer to "Table 13 Function of Clock Correction".

(1) Calculation example 1

In case of current oscillation frequency actual measurement value = 1.000070 [Hz], target oscillation frequency = 1.000000 [Hz], B0 = 0 (Minimum resolution = 3.052 ppm)

$$\begin{aligned} \text{Correction value} &= 128 - \text{Integral value} \left(\frac{(1.000070) - (1.000000)}{(1.000070) \times (3.052 \times 10^{-6})} \right) \\ &= 128 - \text{Integral value} (22.93) = 128 - 22 = 106 \end{aligned}$$

Convert the correction value "106" to 7-bit binary and obtain "1101010b".

Reverse the correction value "1101010b" and set it to B7 to B1 of the clock correction register.

Thus, set the clock correction register:

(B7, B6, B5, B4, B3, B2, B1, B0) = (0, 1, 0, 1, 0, 1, 1, 0)

1.2 If current oscillation frequency < target frequency (in case the clock is slow)

$$\text{Correction value} = \text{Integral value} \left(\frac{(\text{Target oscillation frequency}) - (\text{Current oscillation frequency actual measurement value})}{(\text{Current oscillation frequency actual measurement value}) \times (\text{Minimum resolution})} \right) + 1$$

Caution The figure range which can be corrected is that the calculated value is from 0 to 62.

(1) Calculation example 2

In case of current oscillation frequency actual measurement value = 0.999920 [Hz], target oscillation frequency = 1.000000 [Hz]. B0 = 0 (Minimum resolution = 3.052 ppm)

$$\begin{aligned} \text{Correction value} &= \text{Integral value} \left(\frac{(1.000000) - (0.999920)}{(0.999920) \times (3.052 \times 10^{-6})} \right) + 1 \\ &= \text{Integral value} (26.21) + 1 = 26 + 1 = 27 \end{aligned}$$

Thus, set the clock correction register:

(B7, B6, B5, B4, B3, B2, B1, B0) = (1, 1, 0, 1, 1, 0, 0, 0)

(2) Calculation example 3

In case of current oscillation frequency actual measurement value = 0.999920 [Hz], target oscillation frequency = 1.000000 [Hz], B0 = 1 (Minimum resolution = 1.017 ppm)

$$\begin{aligned} \text{Correction value} &= \text{Integral value} \left(\frac{(1.000000) - (0.999920)}{(0.999920) \times (1.017 \times 10^{-6})} \right) + 1 \\ &= \text{Integral value} (78.66) + 1 \end{aligned}$$

This calculated value exceeds the correctable range 0 to 62.

B0 = "1" (minimum resolution = 1.017 ppm) indicates the correction is impossible.

2. Setting values for registers and correction values

Table 14 Setting Values for Registers and Correction Values (Minimum Resolution: 3.052 ppm (B0 = 0))

B7	B6	B5	B4	B3	B2	B1	B0	Correction Value [ppm]	Rate [s / day]
1	1	1	1	1	1	0	0	192.3	16.61
0	1	1	1	1	1	0	0	189.2	16.35
1	0	1	1	1	1	0	0	186.2	16.09
• • •								• • •	• • •
0	1	0	0	0	0	0	0	6.1	0.53
1	0	0	0	0	0	0	0	3.1	0.26
0	0	0	0	0	0	0	0	0	0
1	1	1	1	1	1	1	0	-3.1	-0.26
0	1	1	1	1	1	1	0	-6.1	-0.53
1	0	1	1	1	1	1	0	-9.2	-0.79
• • •								• • •	• • •
0	1	0	0	0	0	1	0	-189.2	-16.35
1	0	0	0	0	0	1	0	-192.3	-16.61
0	0	0	0	0	0	1	0	-195.3	-16.88

Table 15 Setting Values for Registers and Correction Values (Minimum Resolution: 1.017 ppm (B0 = 1))

B7	B6	B5	B4	B3	B2	B1	B0	Correction Value [ppm]	Rate [s / day]
1	1	1	1	1	1	0	1	64.1	5.54
0	1	1	1	1	1	0	1	63.1	5.45
1	0	1	1	1	1	0	1	62.0	5.36
• • •								• • •	• • •
0	1	0	0	0	0	0	1	2.0	0.18
1	0	0	0	0	0	0	1	1.0	0.09
0	0	0	0	0	0	0	1	0	0
1	1	1	1	1	1	1	1	-1.0	-0.09
0	1	1	1	1	1	1	1	-2.0	-0.18
1	0	1	1	1	1	1	1	-3.0	-0.26
• • •								• • •	• • •
0	1	0	0	0	0	1	1	-63.1	-5.45
1	0	0	0	0	0	1	1	-64.1	-5.54
0	0	0	0	0	0	1	1	-65.1	-5.62

3. How to confirm setting value for register and result of correction

The S-35392A does not adjust the frequency of the crystal oscillation by using the clock correction function. Therefore users cannot confirm if it is corrected or not by measuring output 32.768 kHz. When the function to clock correction is being used, the cycle of 1 Hz clock pulse output from the $\overline{\text{INT2}}$ pin changes once in 20 times or 60 times, as shown in Figure 28.

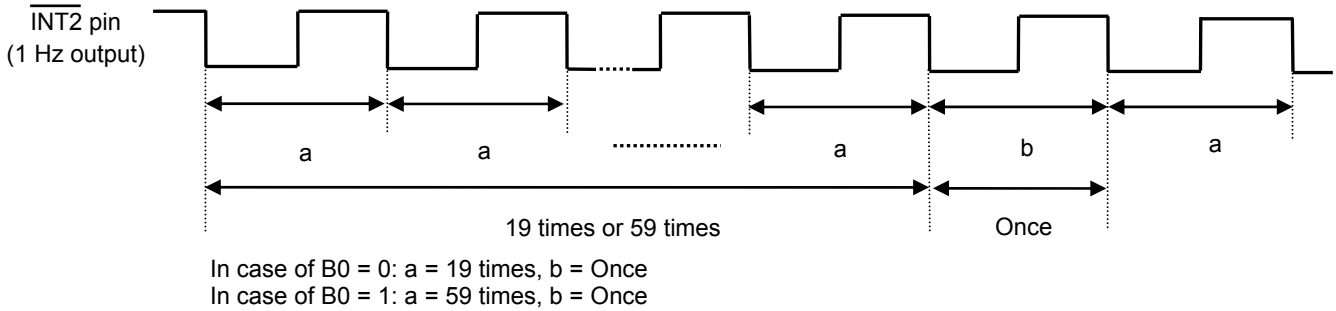

Figure 28 Confirmation of Correction Result

Measure a and b by using the frequency counter^{*1}. Calculate the average frequency (Tave) based on the measurement results.

B0 = 0, $T_{ave} = (a \times 19 + b) \div 20$

B0 = 1, $T_{ave} = (a \times 59 + b) \div 60$

Calculate the error of the clock based on the average frequency (Tave). The following shows an example for confirmation.

Confirmation example: When B0 = 0, 66h is set

Measurement results: a = 1.000080 Hz, b = 0.998493 Hz

	Clock Correction Register Setting Value	Average Frequency [Hz]	Per Day [s]
Before correction	00 h (Tave = a)	1.000080	86393
After correction	66 h (Tave = (a × 19 + b) ÷ 20)	1.00000065	86399.9

Calculating the average frequency allows to confirm the result of correction.

*1. Use a high-accuracy frequency counter of 7 digits or more.

Caution Measure the oscillation frequency under the usage conditions.

■ Serial Interface

The S-35392A transmits / receives various commands via I²C-bus serial interface to read / write data. Regarding transmission is as follows.

1. Start condition

A start condition is when the SDA line changes "H" to "L" when the SCL line is in "H", so that the access starts.

2. Stop condition

A stop condition is when the SDA line changes "L" to "H" when the SCL line is in "H", and the access stops, so that the S-35392A gets standby.

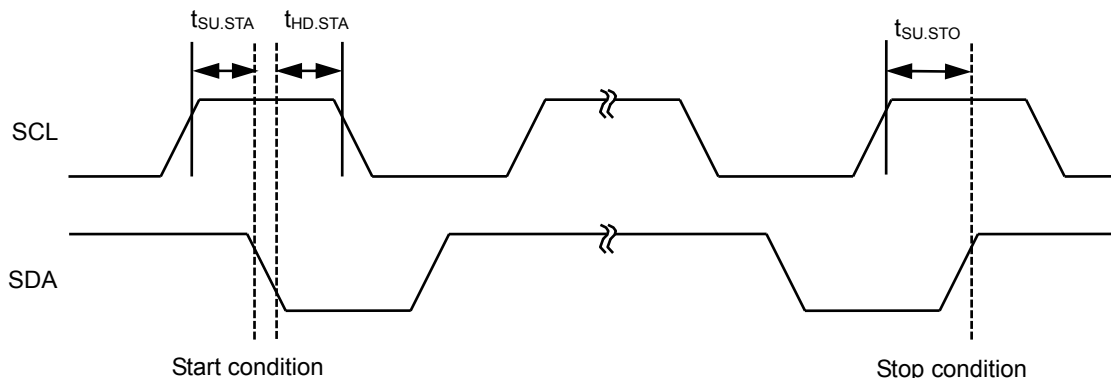

Figure 29 Start / Stop Conditions

3. Data transfer and acknowledgment signal

Data transmission is performed for every 1-byte, after detecting a start condition. Transmit data while the SCL line is in "L", and be careful of spec of $t_{SU.DAT}$ and $t_{HD.DAT}$ when changing the SDA line. If the SDA line changes while the SCL line is in "H", the data will be recognized as start/stop condition in spite of data transmission. Note that by this case, the access will be interrupted.

During data transmission, every moment receiving 1-byte data, the devices which work for receiving data send an acknowledgment signal back. For example, as seen in Figure 30, in case that the S-35392A is the device working for receiving data and the master device is the one working for sending data; when the 8-bit clock pulse falls, the master device releases the SDA line. After that, the S-35392A sends an acknowledgment signal back, and set the SDA line to "L" at the 9-bit clock pulse. The S-35392A does not output an acknowledgment signal is that the access is not being done regularly.

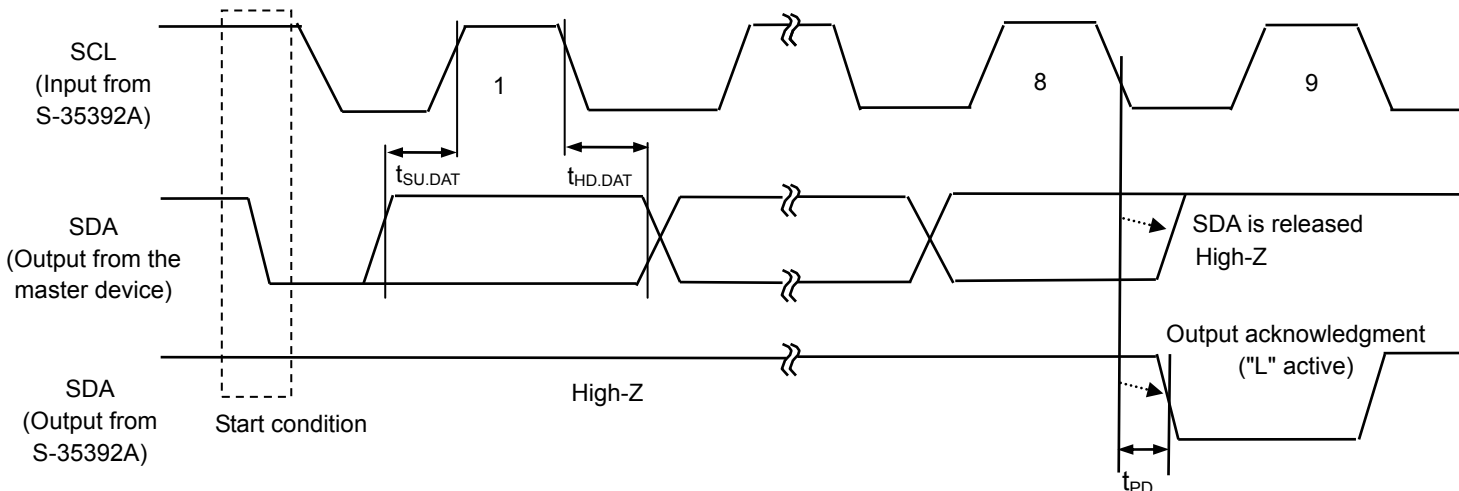

Figure 30 Output Timing of Acknowledgment Signal

The followings are data reading / writing in the S-35392A.

3.1 Data reading in S-35392A

After detecting a start condition, the S-35392A receives device code and command. The S-35392A enters the read-data mode by the read / write bit "1". The data is output from B7 in 1-byte. Input an acknowledgment signal from the master device every moment that the S-35392A outputs 1-byte data. However, do not input an acknowledgment signal (input NO_ACK) for the last data-byte output from the master device. This procedure notifies the completion of reading. Next, input a stop condition to the S-35392A to finish access.

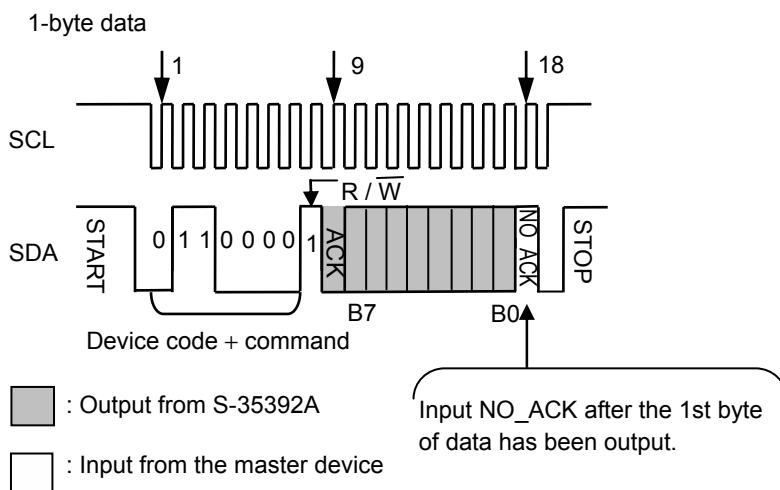

Figure 31 Example of Data Reading 1 (1-Byte Data Register)

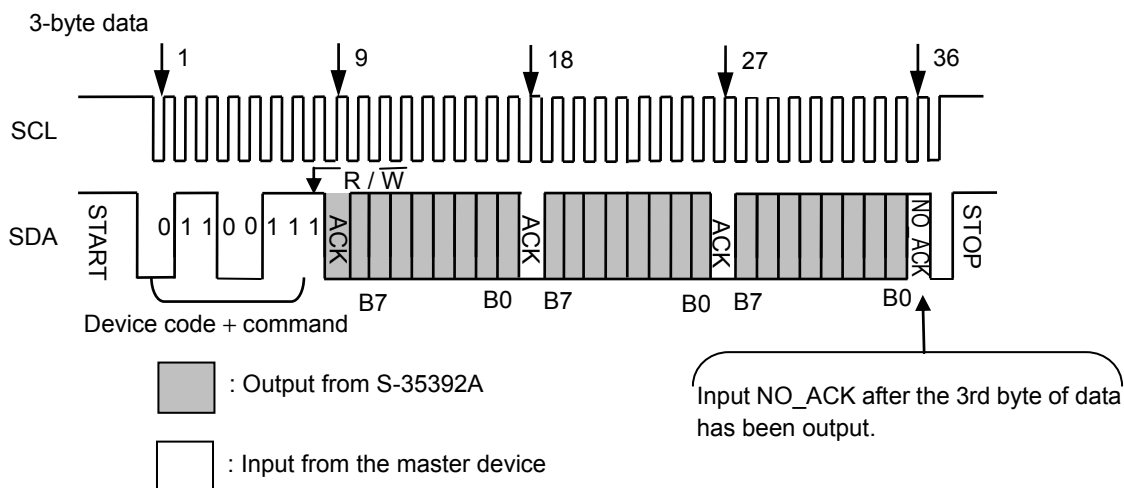

Figure 32 Example of Data Reading 2 (3-Byte Data Register)

3.2 Data writing in S-35392A

After detecting a start condition, the S-35392A receives device code and command. The S-35392A enters the write-data mode by the read / write bit "0". Input data from B7 to B0 in 1-byte. The S-35392A outputs an acknowledgment signal "L" every moment that 1-byte data is input. After receiving the acknowledgment signal which is for the last byte-data, input a stop condition to the S-35392A to finish access.

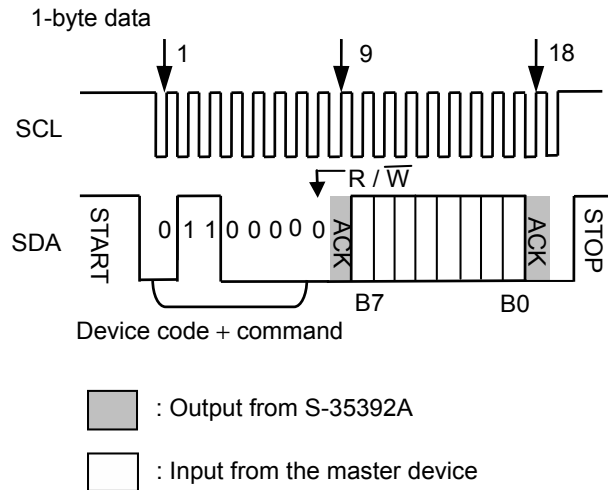

Figure 33 Example of Data Writing 1 (1-Byte Data Register)

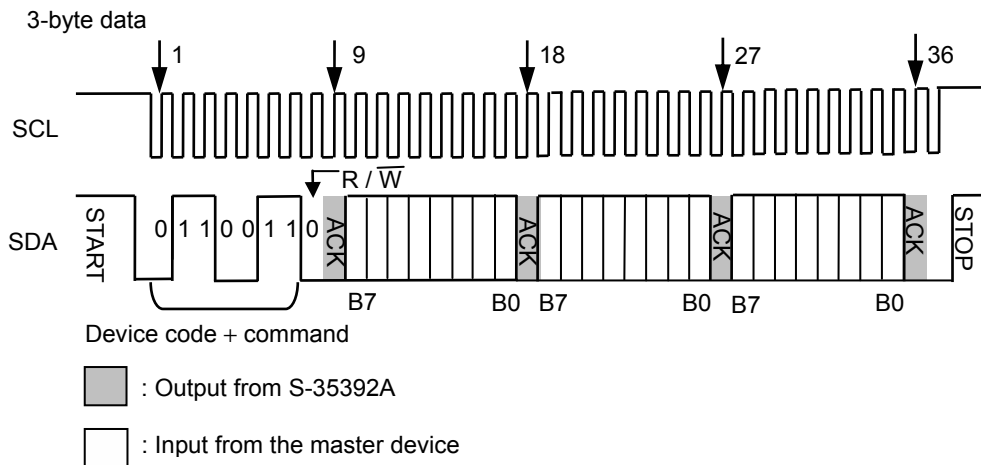
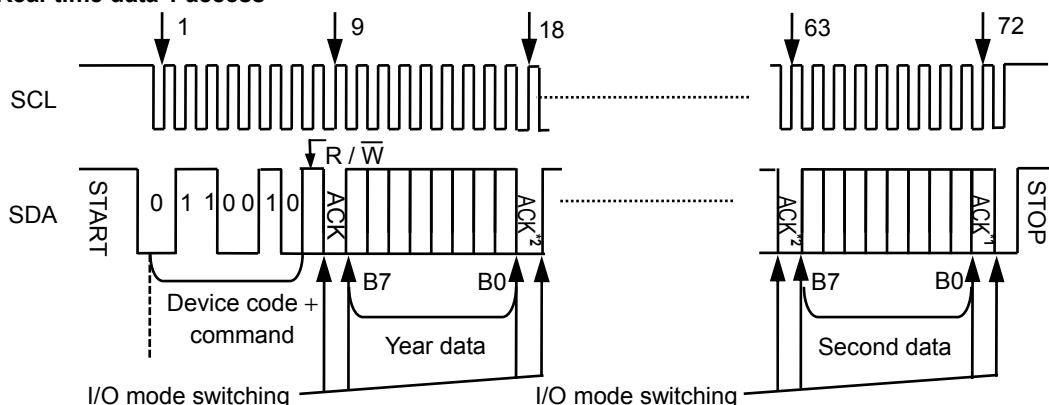

Figure 34 Example of Data Reading 2 (3-Byte Data Register)

4. Data access

4.1 Real-time data 1 access



- *1. Set NO_ACK = 1 when reading.
- *2. Transmit ACK = 0 from the master device to the S-35392A when reading.

Figure 35 Real-Time Data 1 Access

4.2 Real-time data 2 access

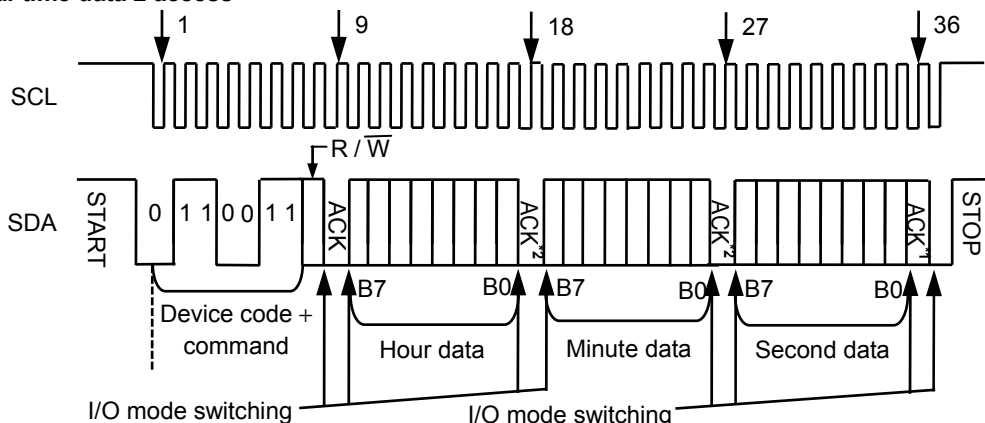

- *1. Set NO_ACK = 1 when reading.
- *2. Transmit ACK = 0 from the master device to the S-35392A when reading.

Figure 36 Real-Time Data 2 Access

4.3 Status register 1 access and status register 2 access

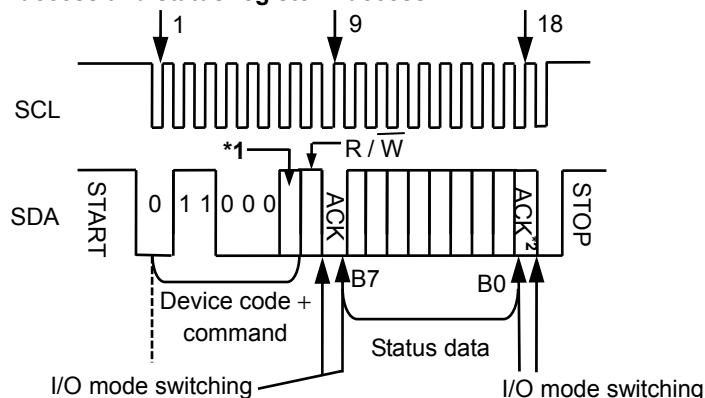

- *1. 0: Status register 1 selected, 1: Status register 2 selected
- *2. Set NO_ACK = 1 when reading.

Figure 37 Status Register 1 Access and Status Register 2 Access

4.4 INT1 register access and INT2 register access

In reading / writing the INT1 and INT2 registers, data varies depending on the setting of the status register 2. Be sure to read / write after setting the status register 2. When setting the alarm by using the status register 2, these registers work as 3-byte alarm time data registers, in other statuses, they work as 1-byte registers. When outputting the user-set frequency, they are the data registers to set up the frequency.

Regarding details of each data, refer to "4. INT1 register and INT2 register" in "■ Configuration of Registers".

Caution Users cannot use both functions of alarm interrupt output and the output of user-set frequency simultaneously.

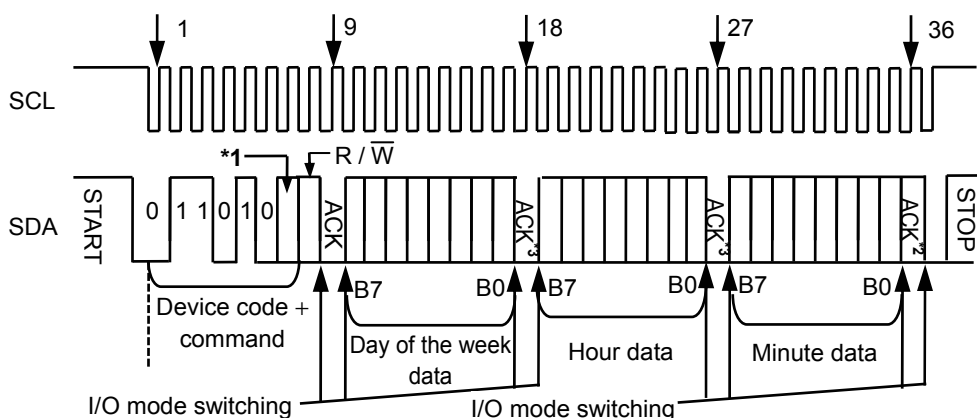

- *1. 0: INT1 register selected, 1: INT2 register selected
- *2. Set NO_ACK = 1 when reading.
- *3. Transmit ACK = 0 from the master device to the S-35392A when reading.

Figure 38 INT1 Register Access and INT2 Register Access

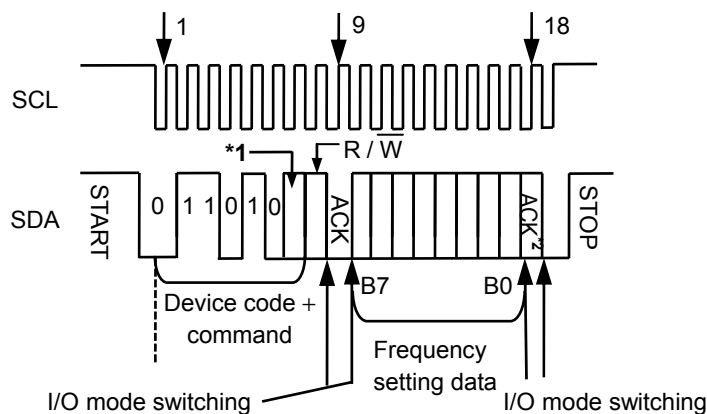

- *1. 0: INT1 register selected, 1: INT2 register selected
- *2. Set NO_ACK = 1 when reading.

Figure 39 INT1 Register and INT2 Register (Data Register for Output Frequency) Access

4.5 Clock correction register access

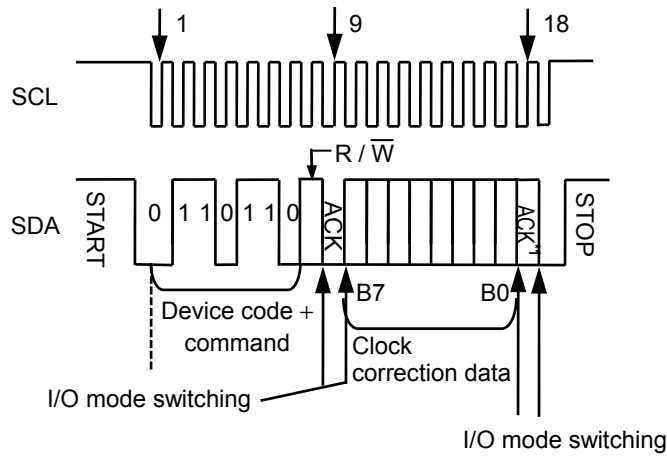

*1. Set NO_ACK = 1 when reading.

Figure 40 Clock Correction Register Access

4.6 Free register access

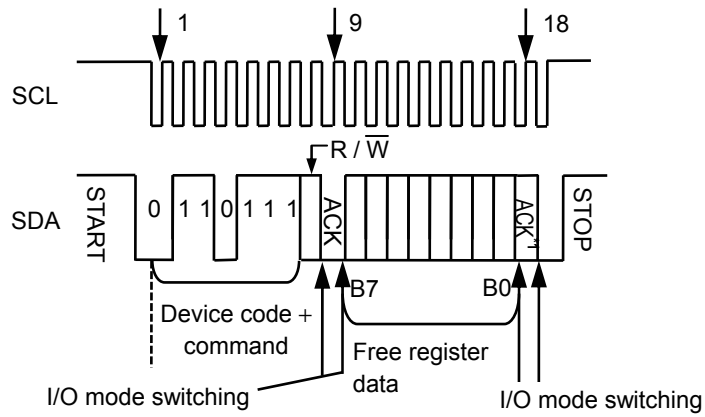

*1. Set NO_ACK = 1 when reading.

Figure 41 Free Register Access

■ Reset After Communication Interruption

In case of communication interruption in the S-35392A, for example, during communication the power supply voltage drops so that only the master device is reset; the S-35392A does not operate the next procedure because the internal circuit keeps the state prior to communication interruption. The S-35392A does not have a reset pin so that users usually reset its internal circuit by inputting a stop condition. However, if the SDA is outputting "L" (during output of acknowledgment signal or reading), the S-35392A does not accept a stop condition from the master device. In this case, users are necessary to finish acknowledgment output or reading of the SDA. **Figure 42** shows how to reset.

First, input a start condition from the master device (the S-35392A cannot detect a start condition because the SDA in the S-35392A is outputting "L"). Next, input a clock pulse equivalent to 7-byte data access (63-clock) from the SCL. During this, release the SDA line for the master device. By this procedure, SDA I/O before communication interruption is finished, so that the SDA line in the S-35392A is released. After that, inputting a stop condition resets the internal circuit so that restore the regular communication. This reset procedure is recommended to perform at initialization of the system after rising the master device's power supply voltage.

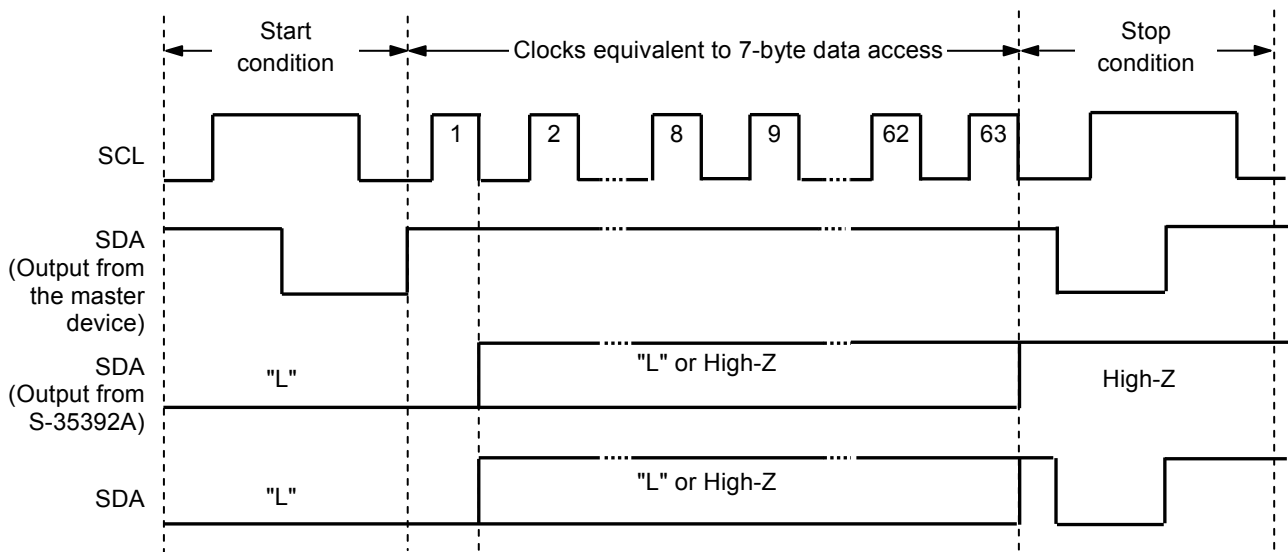
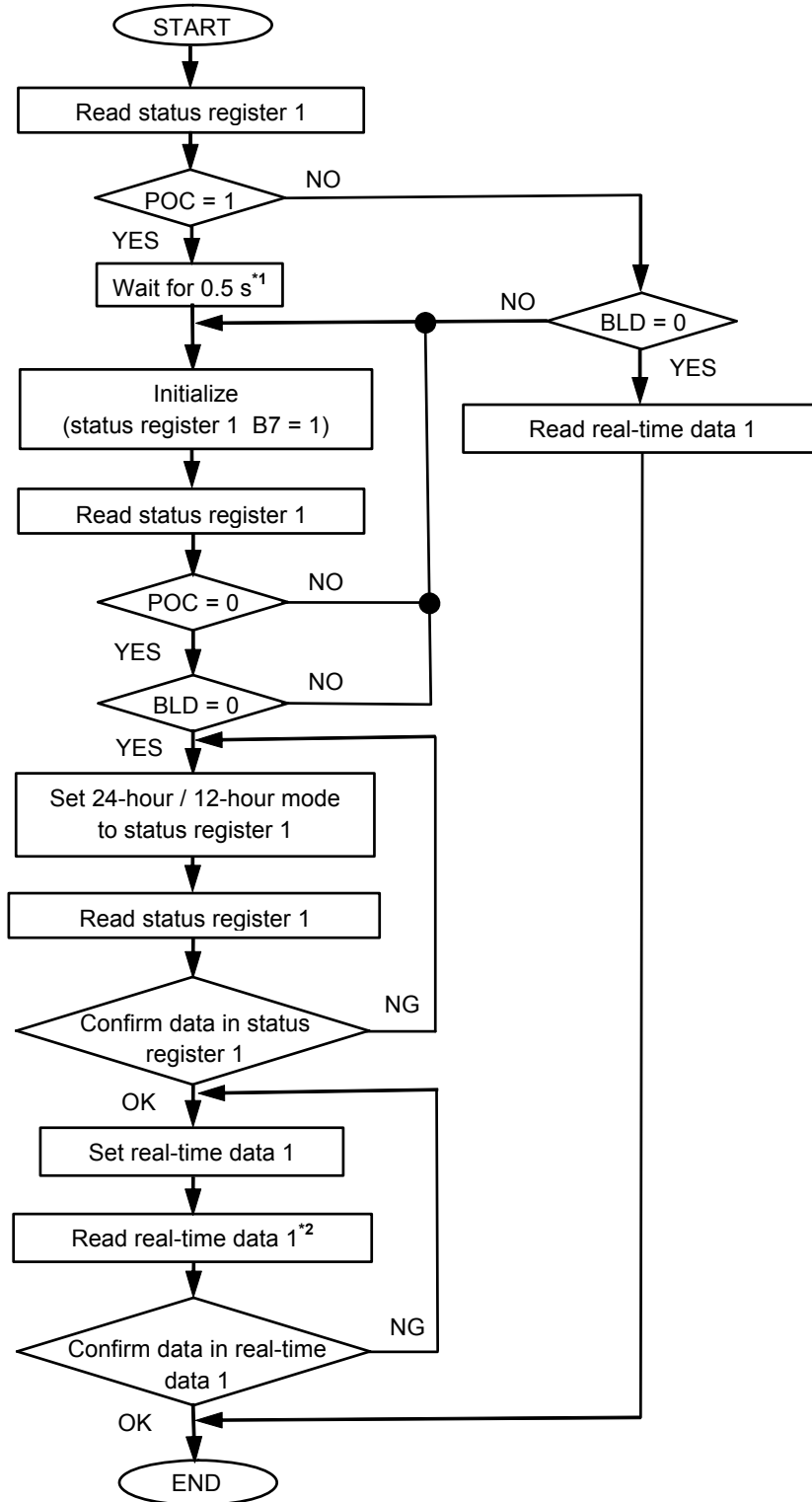

Figure 42 How to Reset

■ Flowchart of Initialization and Example of Real-time Data Set-up

Figure 43 is a recommended flowchart when the master device shifts to a normal operation status and initiates communication with the S-35392A. Regarding how to apply power, refer to "■ Power-on Detection Circuit and Register Status". It is unnecessary for users to comply with this flowchart of real-time data strictly. And if using the default data at initializing, it is also unnecessary to set up again.



*1. Do not communicate for 0.5 seconds since the power-on detection circuit is in operation.

*2. Reading the real-time data 1 should be completed within 1 second after setting the real-time data 1.

Figure 43 Example of Initialization Flowchart

■ Examples of Application Circuits

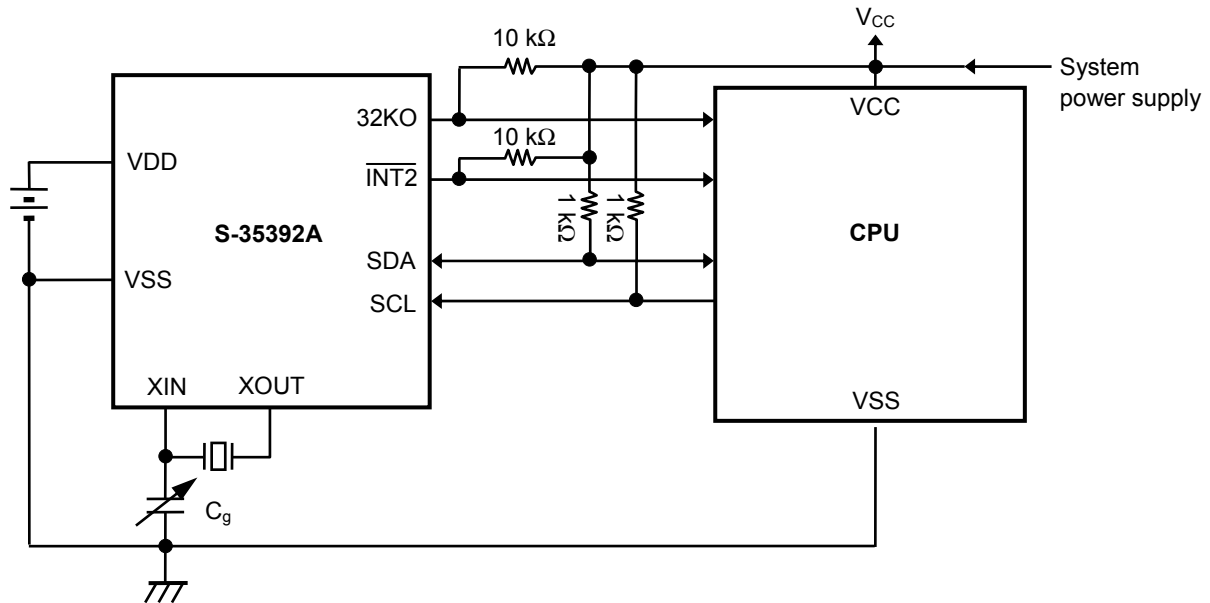

- Caution**
1. Because the I/O pin has no protective diode on the VDD side, the relation of $V_{CC} \geq V_{DD}$ is possible, but pay careful attention to the specifications.
 2. Start communication under stable condition after power-on the power supply in the system.

Figure 44 Application Circuit 1

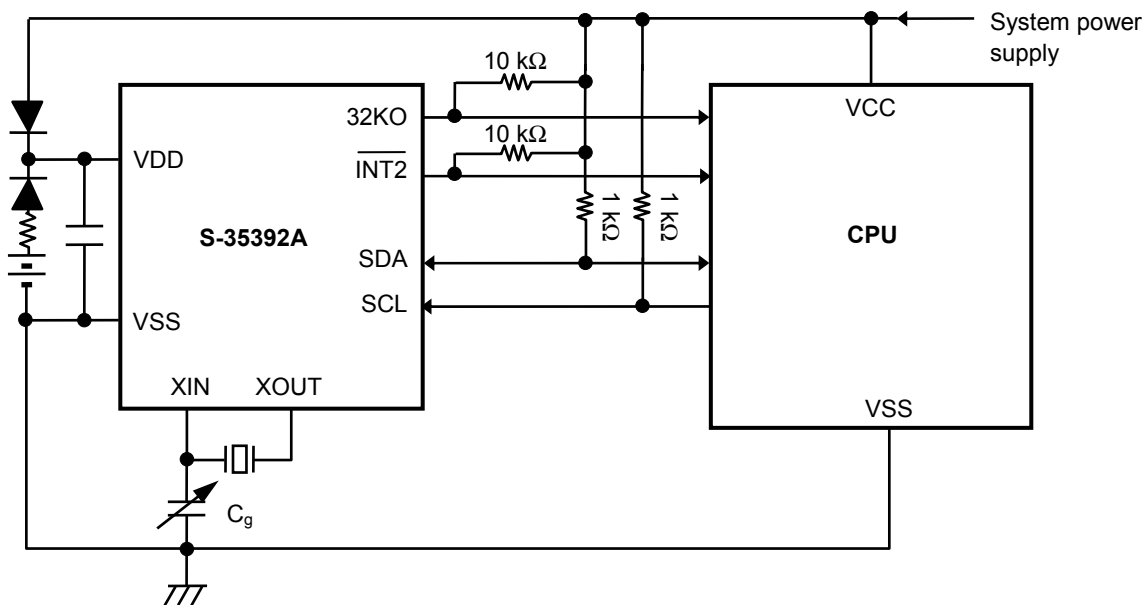

Caution Start communication under stable condition after power-on the power supply in the system.

Figure 45 Application Circuit 2

Caution The above connection diagrams do not guarantee operation. Set the constants after performing sufficient evaluation using the actual application.

■ Adjustment of Oscillation Frequency

1. Configuration of oscillator

Since crystal oscillation is sensitive to external noise (the clock accuracy is affected), the following measures are essential for optimizing the oscillation configuration.

- Place the S-35392A, crystal oscillator, and external capacitor (C_g) as close to each other as possible.
- Increase the insulation resistance between pins and the substrate wiring patterns of XIN and XOUT.
- Do not place any signal or power lines close to the oscillator.
- Locating the GND layer immediately below the oscillator is recommended.
- Locate the bypass capacitor adjacent to the power supply pin of the S-35392A.

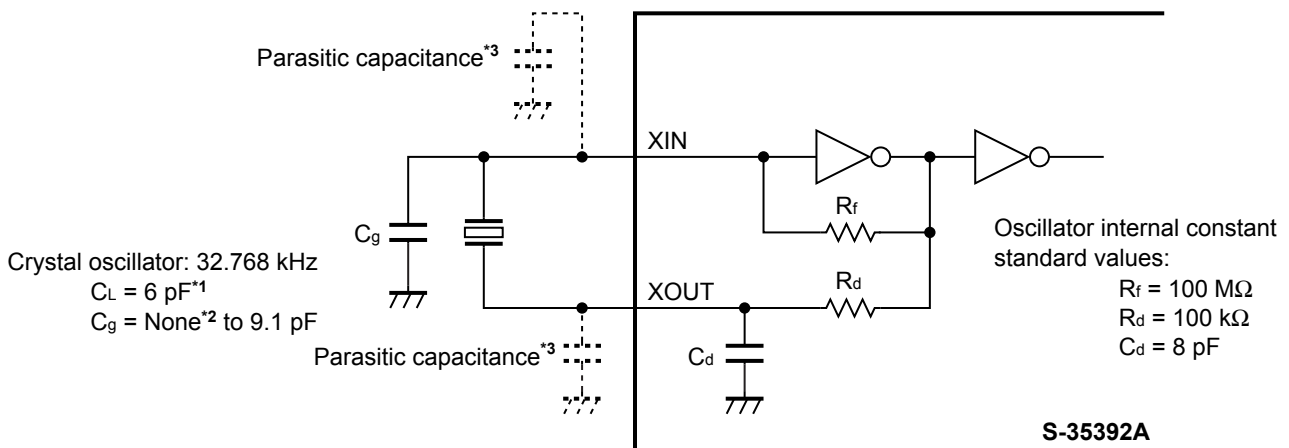

*1. When setting the value for the crystal oscillator's C_L as 7 pF, connect C_d externally if necessary.

*2. The oscillator operates even when C_g is not connected. Note that the oscillation frequency is in the direction that it advances.

*3. Design the board so that the parasitic capacitance is within 5 pF.

Figure 46 Connection Diagram 1

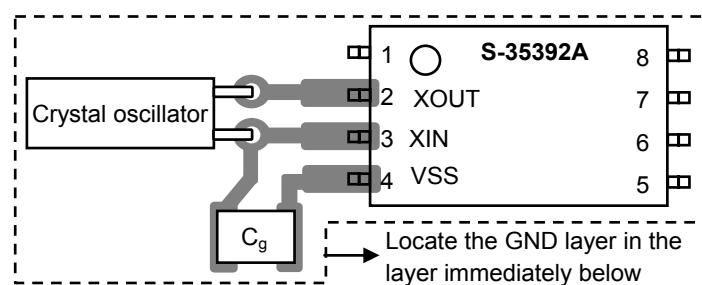

Figure 47 Connection Diagram 2

- Caution**
1. When using the crystal oscillator with a C_L exceeding the rated value (7 pF) (e.g: $C_L = 12.5 \text{ pF}$), oscillation operation may become unstable. Use a crystal oscillator with a C_L value of 6 pF or 7 pF.
 2. Oscillation characteristics is subject to the variation of each component such as substrate parasitic capacitance, parasitic resistance, crystal oscillator, and C_g . When configuring an oscillator, pay sufficient attention for them.

2. Measurement of oscillation frequency

When the S-35392A is turned on, a signal of 32.768 kHz is output from the 32KO pin. Turn the power on and measure the signal with a frequency counter following the circuit configuration shown in **Figure 48**.

Remark If the error range is ± 1 ppm in relation to 32.768 kHz, the time is shifted by approximately 2.6 seconds per month (calculated using the following mode).
 10^{-6} (1 ppm) \times 60 seconds \times 60 minutes \times 24 hours \times 30 days = 2.592 seconds

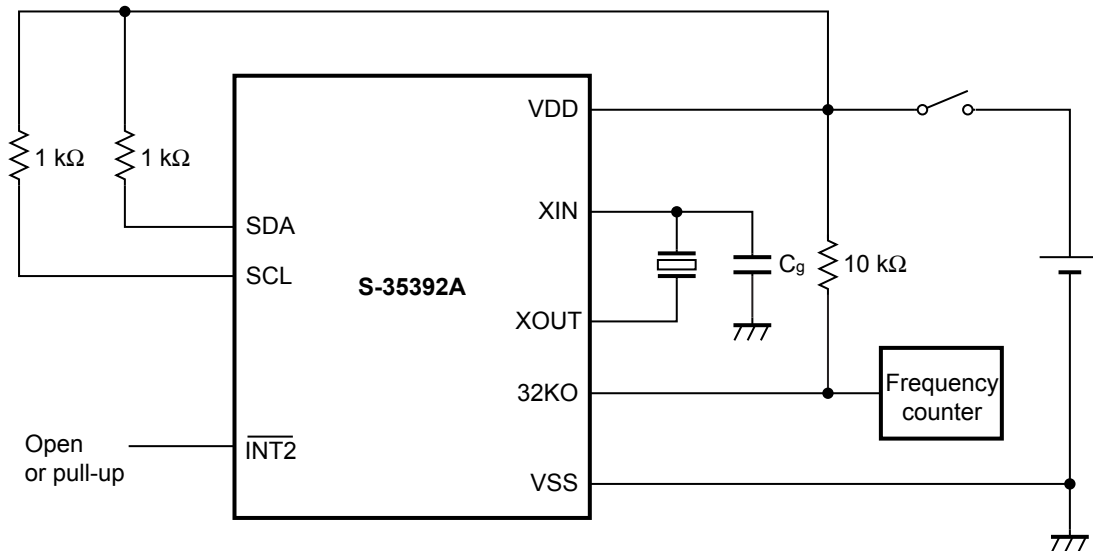

Figure 48 Configuration of Oscillation Frequency Measurement Circuit

- Caution**
1. Use a high-accuracy frequency counter of 7 digits or more.
 2. Measure the oscillation frequency under the usage conditions.

3. Adjustment of oscillation frequency

3.1 Adjustment by setting C_g

Matching of the crystal oscillator with the nominal frequency must be performed with the stray capacitance on the board included. Select a crystal oscillator and optimize the C_g value in accordance with the flowchart below.

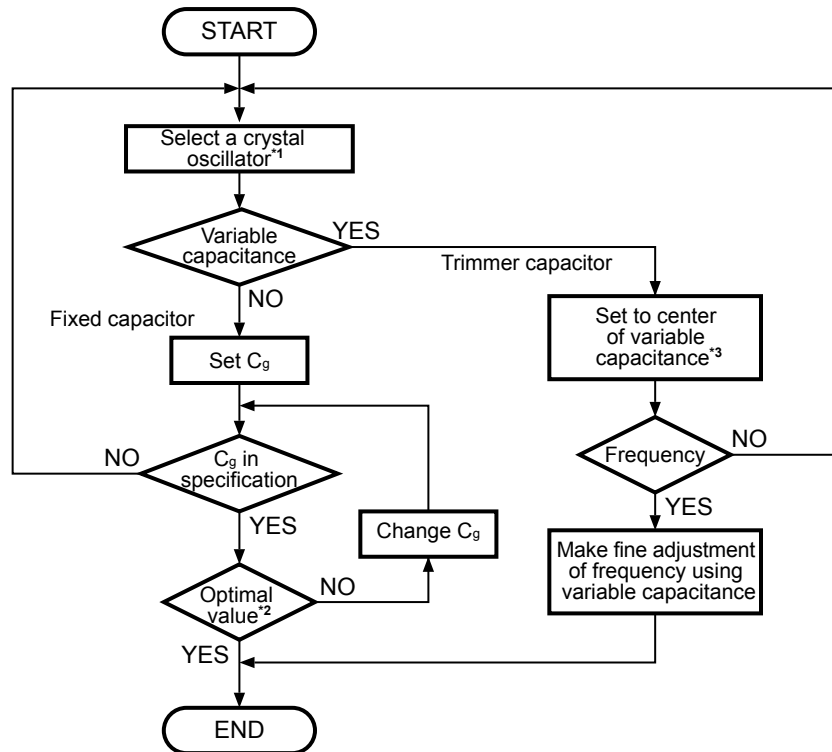

*1. Request a crystal manufacturer for matching evaluation between the IC and a crystal. The recommended crystal characteristic values are, C_L value (load capacitance) = 6 pF, R_1 value (equivalent serial resistance) = 50 k Ω max.

*2. The C_g value must be selected on the actual PCB since it is affected by parasitic capacitance. Select the external C_g value in a range of 0 pF to 9.1 pF.

*3. Adjust the rotation angle of the variable capacitance so that the capacitance value is slightly smaller than the center, and confirm the oscillation frequency and the center value of the variable capacitance. This is done in order to make the capacitance of the center value smaller than one half of the actual capacitance value because a smaller capacitance value increases the frequency variation.

Figure 49 Crystal Oscillator Setting Flow

- Caution**
1. The oscillation frequency varies depending on the ambient temperature and power supply voltage. Refer to "■ Characteristics (Typical Data)".
 2. The 32.768 kHz crystal oscillator operates more slowly at an operating temperature higher or lower than +20°C to +25°C. Therefore, it is recommended to set the oscillator to operate slightly faster at normal temperature.

■ Precautions

- Although the IC contains a static electricity protection circuit, static electricity or voltage that exceeds the limit of the protection circuit should not be applied.
- Seiko Instruments Inc. assumes no responsibility for the way in which this IC is used in products created using this IC or for the specifications of that product, nor does Seiko Instruments Inc. assume any responsibility for any infringement of patents or copyrights by products that include this IC either in Japan or in other countries.

■ Characteristics (Typical Data)

1. Standby current vs. V_{DD} characteristics

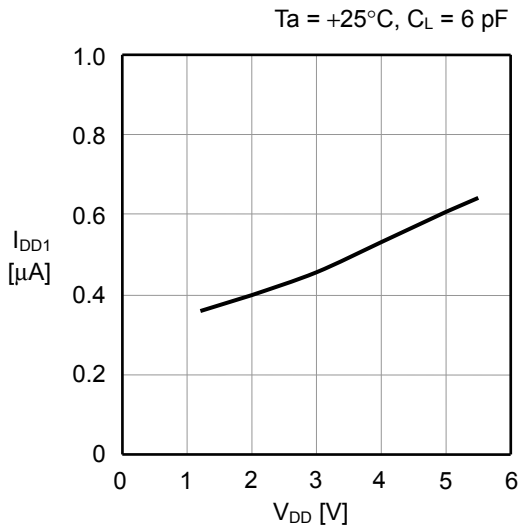

2. Current consumption vs. Input clock characteristics

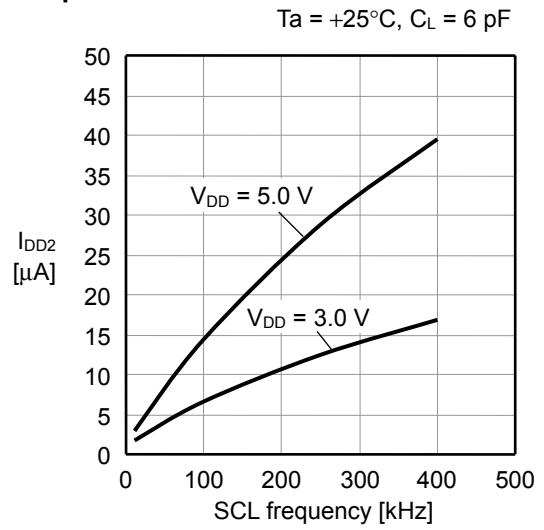

3. Standby current vs. Temperature characteristics

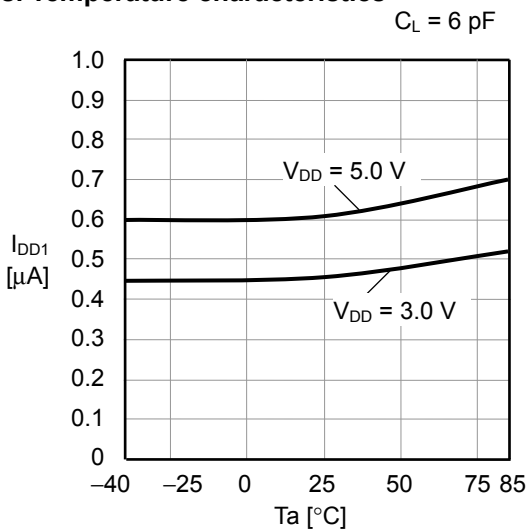

4. Standby current vs. C_g characteristics

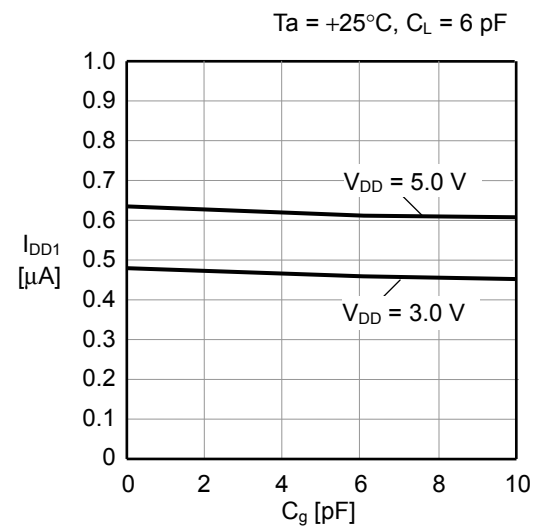

5. Oscillation frequency vs. C_g characteristics

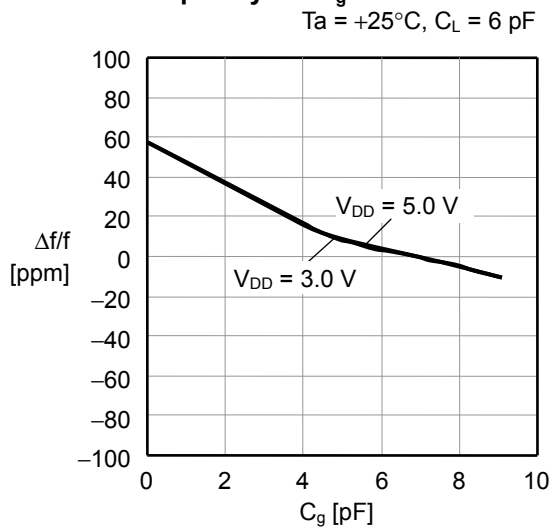

6. Oscillation frequency vs. V_{DD} characteristics

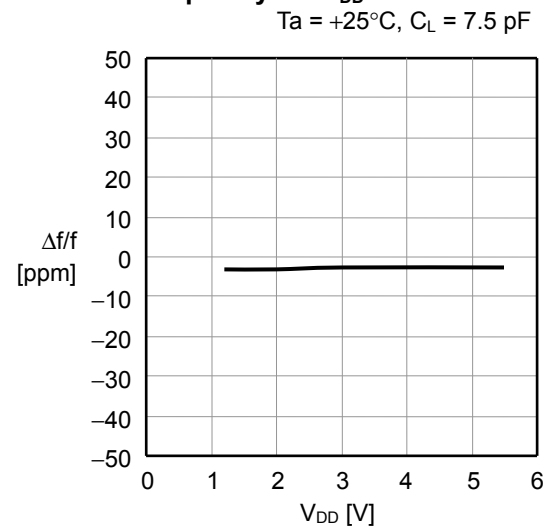

7. Oscillation frequency vs. Temperature characteristics

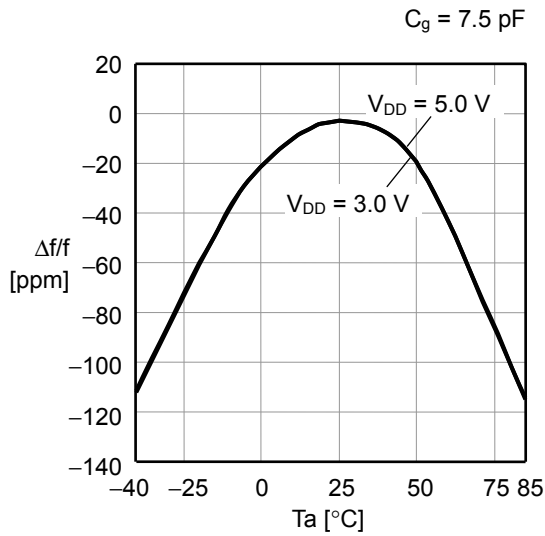

8. Oscillation start time vs. C_g characteristics

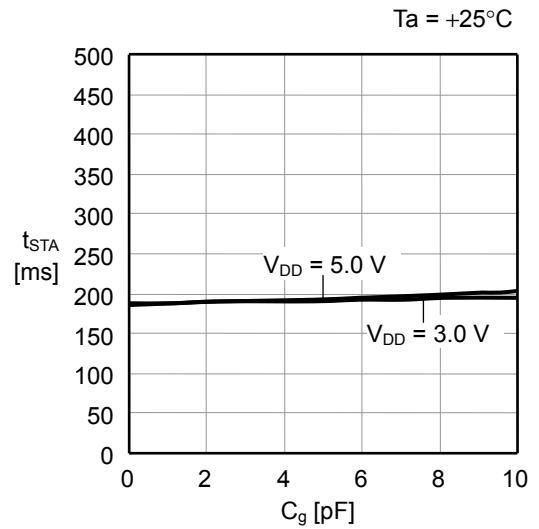

9. Output current characteristics 1 (V_{OUT} vs. I_{OL1})

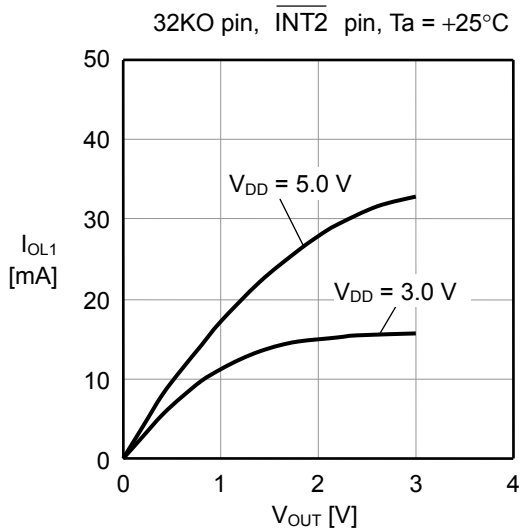

10. Output current characteristics 2 (V_{OUT} vs. I_{OL2})

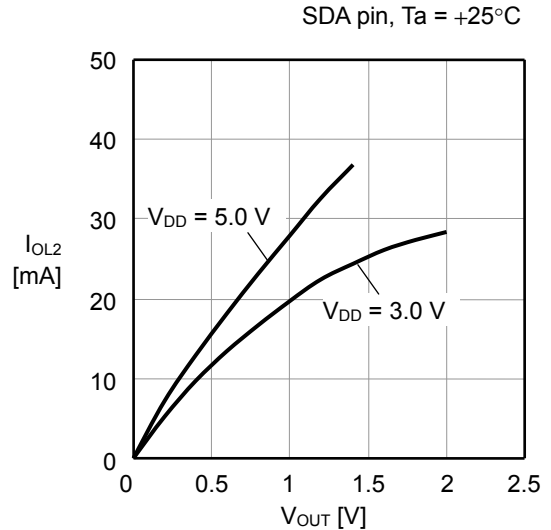

11. BLD detection, release voltage, V_{DDT} (min.) vs. Temperature characteristics

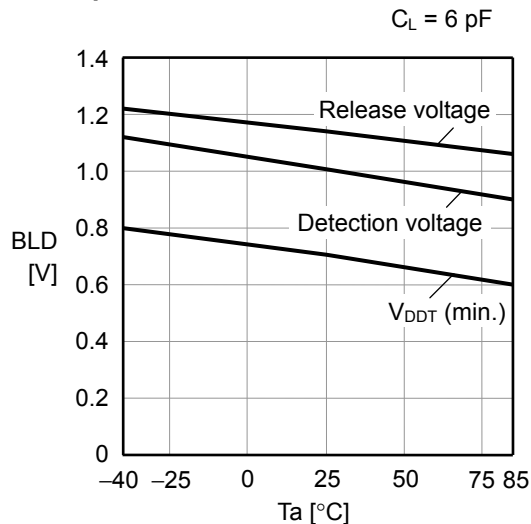

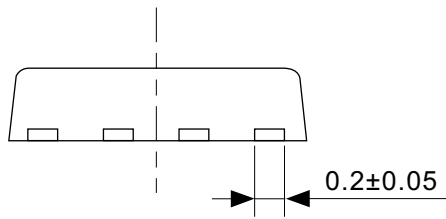
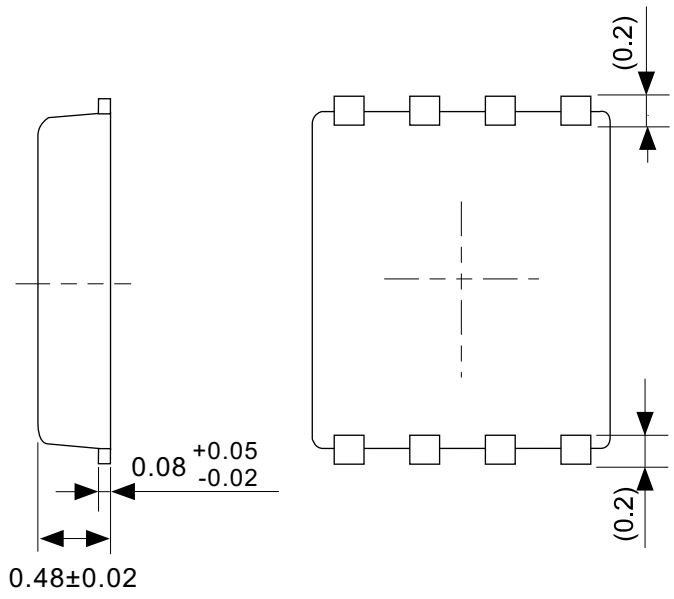
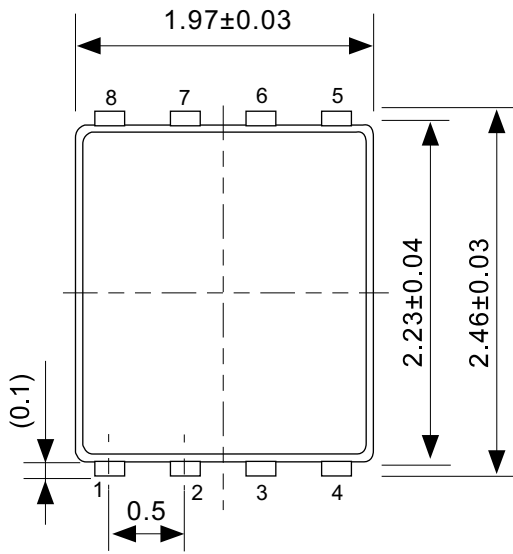

No. PH008-A-P-SD-2.0

TITLE	SNT-8A-A-PKG Dimensions
No.	PH008-A-P-SD-2.0
SCALE	
UNIT	mm
Seiko Instruments Inc.	

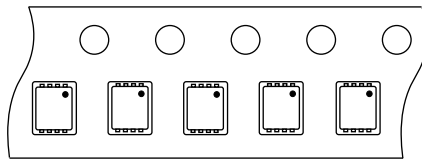
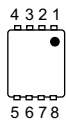
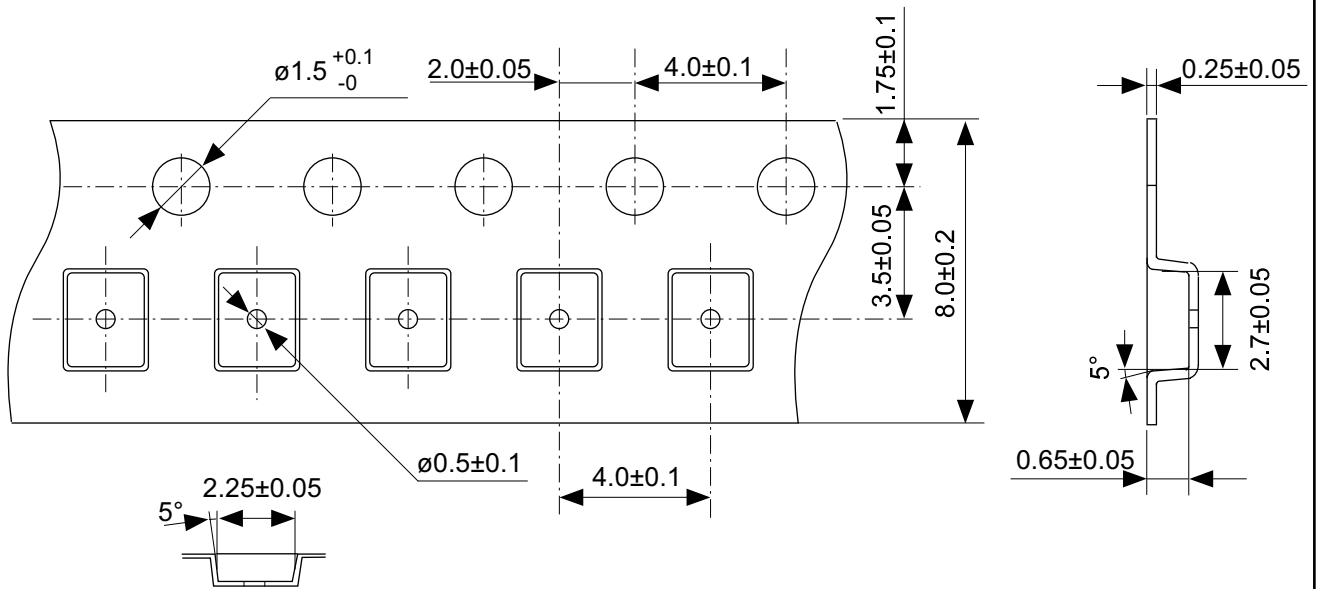

Feed direction

No. PH008-A-C-SD-1.0

TITLE	SNT-8A-A-Carrier Tape
No.	PH008-A-C-SD-1.0
SCALE	
UNIT	mm
Seiko Instruments Inc.	

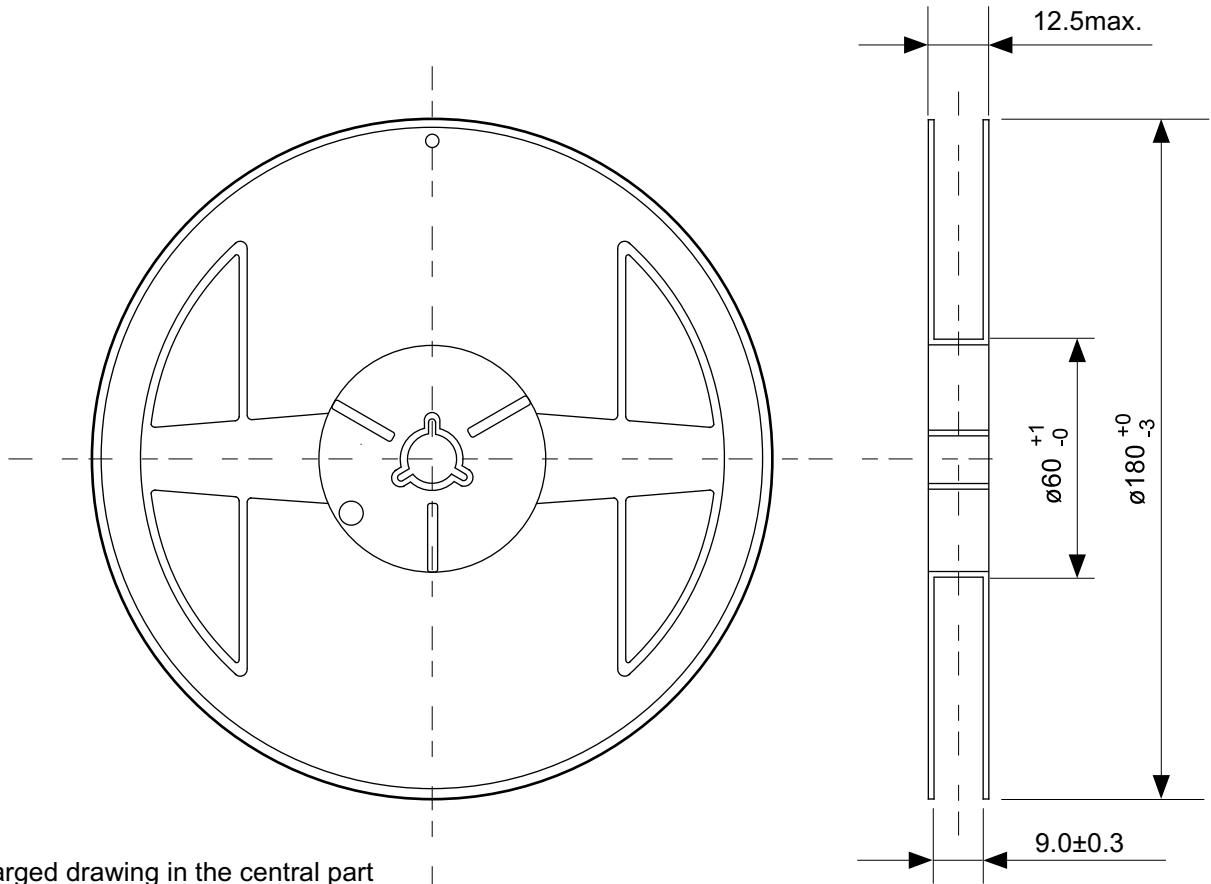

Enlarged drawing in the central part

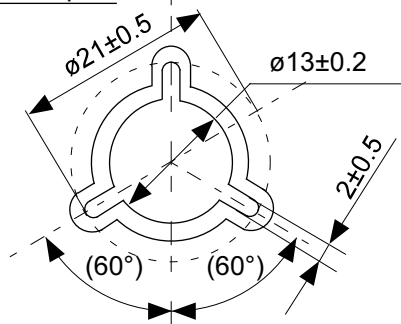

No. PH008-A-R-SD-1.0

TITLE	SNT-8A-A-Reel		
No.	PH008-A-R-SD-1.0		
SCALE		QTY.	5,000
UNIT	mm		
Seiko Instruments Inc.			

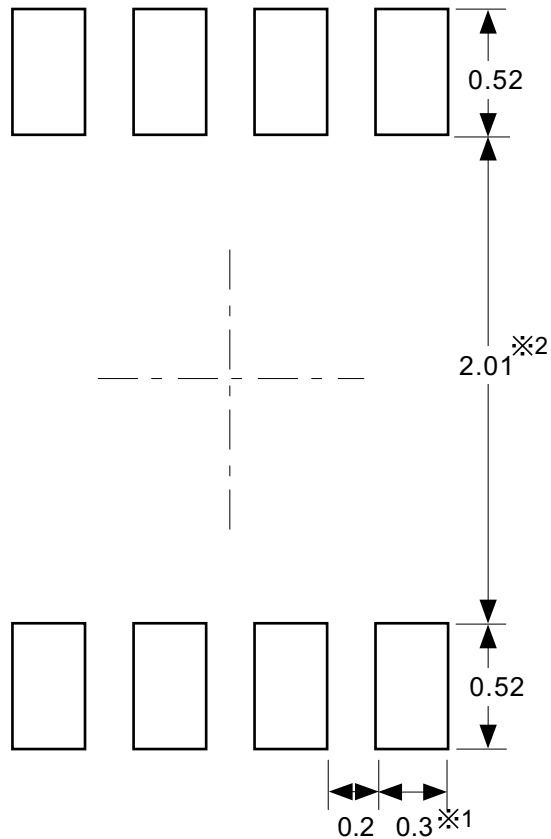

※1. ランドパターンの幅に注意してください (0.25 mm min. / 0.30 mm typ.).
 ※2. パッケージ中央にランドパターンを広げないでください (1.96 mm ~ 2.06 mm)。

- 注意
1. パッケージのモールド樹脂下にシルク印刷やハンダ印刷などしないでください。
 2. パッケージ下の配線上のソルダーレジストなどの厚みをランドパターン表面から0.03 mm以下にしてください。
 3. マスク開口サイズと開口位置はランドパターンと合わせてください。
 4. 詳細は "SNTパッケージ活用の手引き" を参照してください。

※1. Pay attention to the land pattern width (0.25 mm min. / 0.30 mm typ.).
 ※2. Do not widen the land pattern to the center of the package (1.96 mm to 2.06mm).

- Caution**
1. Do not do silkscreen printing and solder printing under the mold resin of the package.
 2. The thickness of the solder resist on the wire pattern under the package should be 0.03 mm or less from the land pattern surface.
 3. Match the mask aperture size and aperture position with the land pattern.
 4. Refer to "SNT Package User's Guide" for details.

※1. 请注意焊盘模式的宽度 (0.25 mm min. / 0.30 mm typ.).
 ※2. 请勿向封装中间扩展焊盘模式 (1.96 mm ~ 2.06 mm)。

- 注意
1. 请勿在树脂型封装的下面印刷丝网、焊锡。
 2. 在封装下、布线上的阻焊膜厚度 (从焊盘模式表面起) 请控制在0.03 mm以下。
 3. 掩膜的开口尺寸和开口位置请与焊盘模式对齐。
 4. 详细内容请参阅 "SNT封装的应用指南"。

No. PH008-A-L-SD-4.0

TITLE	SNT-8A-A-Land Recommendation
No.	PH008-A-L-SD-4.0
SCALE	
UNIT	mm
Seiko Instruments Inc.	



Seiko Instruments Inc.
www.sii-ic.com

- The information described herein is subject to change without notice.
- Seiko Instruments Inc. is not responsible for any problems caused by circuits or diagrams described herein whose related industrial properties, patents, or other rights belong to third parties. The application circuit examples explain typical applications of the products, and do not guarantee the success of any specific mass-production design.
- When the products described herein are regulated products subject to the Wassenaar Arrangement or other agreements, they may not be exported without authorization from the appropriate governmental authority.
- Use of the information described herein for other purposes and/or reproduction or copying without the express permission of Seiko Instruments Inc. is strictly prohibited.
- The products described herein cannot be used as part of any device or equipment affecting the human body, such as exercise equipment, medical equipment, security systems, gas equipment, vehicle equipment, in-vehicle equipment, aviation equipment, aerospace equipment, and nuclear-related equipment, without prior written permission of Seiko Instruments Inc.
- The products described herein are not designed to be radiation-proof.
- Although Seiko Instruments Inc. exerts the greatest possible effort to ensure high quality and reliability, the failure or malfunction of semiconductor products may occur. The user of these products should therefore give thorough consideration to safety design, including redundancy, fire-prevention measures, and malfunction prevention, to prevent any accidents, fires, or community damage that may ensue.