



CRYSTAL OSCILLATOR

SPXO

SG-645 / SG-636 series

- Frequency range : 2.21675 MHz to 135 MHz
- Supply voltage : 2.5 V / 3.3 V / 5.0 V
- Function : Output enable(OE) or Standby(\overline{ST})
- External dimensions : 7.1 × 5.1 × 1.5 mm (t: Max.)...SG-645
10.5 × 5.8 × 2.7 mm (t: Max.)...SG-636



Product Number (please contact us)

SG-645 : Q33645xx2xxxx00

SG-636 : Q33636xx2xxxx00



Actual size

SG-645 series



SG-636 series



Specifications (characteristics)

Item	Symbol	Specifications			Conditions / Remarks
		SG-636 PTF	SG-636 PCE SG-636 SCE	SG-636 PDE	
Output frequency range	f_0	2.21675 MHz to 41.000 MHz	2.21675 MHz to 40.000 MHz	2.21675 MHz to 40.000 MHz	
Supply voltage	V_{CC}	5.0 V \pm 0.5 V	3.3 V \pm 0.3 V	2.5 V \pm 0.25 V	
Storage temperature	T_{stg}	-55 °C to +100 °C			Store as bare product.
Operating temperature	T_{use}	-20 °C to +70 °C			
Frequency tolerance	f_{tol}	C: $\pm 100 \times 10^{-6}$			-20 °C to +70 °C
Current consumption	I_{CC}	17 mA Max.	9 mA Max.	5 mA Max.	No load condition
Disable current	I_{dis}	10 mA Max.	5 mA Max.	3 mA Max.	OE=GND
Stand-by current	I_{std}	—	2 μ A Max.	—	\overline{ST} =GND(SCE)
Symmetry	SYM	40 % to 60 %	45 % to 55 %		CMOS load:50 % V_{CC} level
		45 % to 55 %	—		TTL load: 1.4 V level
Output voltage	V_{OH}	V_{CC} -0.4 V Min.			I_{OH} =-8 mA(PTF) / -4 mA(SCE,PCE) / -3.2 mA(PDE)
	V_{OL}	0.4 V Max.			I_{OL} =16 mA(PTF) / 4 mA(SCE,PCE) / 3.2 mA(PDE)
Output load condition (TTL)	L_{TTL}	10 TTL Max.	—		$L_{CMOS} \leq 15$ pF
Output load condition (CMOS)	L_{CMOS}	50 pF Max.	30 pF Max.	15 pF Max.	
Input voltage	V_{IH}	2.0 V Min.	80 % V_{CC} Min.		OE Terminal or \overline{ST} Terminal (SCE)
	V_{IL}	0.8 V Max.	20 % V_{CC} Max.		
Rise time / Fall time	t_r / t_f	7 ns Max.	5 ns Max.		CMOS load:20 % V_{CC} to 80 % V_{CC} level
		5 ns Max.	—		TTL load:0.4 V to 2.4 V level
Start-up time	t_{str}	4 ms Max.	4 ms Max.		Time at minimum supply voltage to be 0 s
Frequency aging	f_{aging}	$\pm 5 \times 10^{-6}$ / year Max.			+25 °C, V_{CC} =5.0 V/3.3 V/2.5 V, First year

Specifications (characteristics)

Item	Symbol	Specifications			Conditions / Remarks
		SG-636 PTG	SG-636 PHG	SG-636 PCG SG-636 SCG	
Output frequency range	f_0	2.21675 MHz to 33.000 MHz *1			
Supply voltage	V_{CC}	4.5 V to 5.5 V	2.7 V to 3.6 V		
Storage temperature	T_{stg}	-55 °C to +100 °C			Store as bare product.
Operating temperature	T_{use}	-20 °C to +70 °C			
Frequency tolerance	f_{tol}	B: $\pm 50 \times 10^{-6}$ C: $\pm 100 \times 10^{-6}$			-20 °C to +70 °C
Current consumption	I_{CC}	25 mA Max.	12 mA Max.		No load condition
Disable current	I_{dis}	20 mA Max.	10 mA Max.		OE=GND (PTG,PHG,PCG)
Stand-by current	I_{std}	—	50 μ A Max.		\overline{ST} =GND (SCG)
Symmetry	SYM	—	45 % to 55 %		50 % V_{CC} level, L_{CMOS} =25 pF
		40 % to 60 %	—		1.4 V level, L_{CMOS} =25 pF
Output voltage	V_{OH}	2.4 V Min.	—	V_{CC} -0.4 V Min.	I_{OH} =-8 mA
	V_{OL}	—	V_{CC} -0.4 V Min.	—	I_{OH} =-16 mA
Output load condition	L_{CMOS}	—	0.4 V Max.		I_{OL} =8 mA
		25 pF Max.	—		I_{OL} =16 mA
Input voltage	V_{IH}	2.0 V Min.	70 % V_{CC} Min.		OE Terminal or \overline{ST} Terminal
	V_{IL}	0.8 V Max.	20 % V_{CC} Max.		
Rise time / Fall time	t_r / t_f	—	3.4 ns Max.	4 ns Max.	20 % V_{CC} to 80 % V_{CC} level, $L_{CMOS} \leq 25$ pF
		2.4 ns Max.	—		TTL load:0.4 V to 2.4 V level, $L_{CMOS} \leq 25$ pF
Start-up time	t_{str}	12 ms Max.			$t=0$ at 90 % V_{CC}
Frequency aging	f_{aging}	$\pm 5 \times 10^{-6}$ / year Max.			+25 °C, V_{CC} =5.0 V/ 3.3 V, First year

*1 4.1250 MHz < f_0 < 4.4336 MHz, 8.2500 MHz < f_0 < 8.8672 MHz, 16.500 MHz < f_0 < 17.7344 MHz : Unavailable

Specifications (characteristics)

Item	Symbol	Specifications			Conditions / Remarks
		SG-636 PTW / STW SG-645 PTW / STW	SG-636 PHW / SHW SG-645 PHW / SHW	SG-636 PCW / SCW SG-645 PCW / SCW	
Output frequency range	f_0	32.001 MHz to 135.000 MHz			
Supply voltage	V_{CC}	5.0 V \pm 0.5 V		3.3 V \pm 0.3 V	
Storage temperature	T_{stg}	SG-636***: -55 °C to +100 °C / SG-645***: -55 °C to +125 °C			Store as bare product.
Operating temperature	T_{use}	-20 °C to +70 °C			
Frequency tolerance	f_{tol}	—		M: $\pm 100 \times 10^{-6}$	SG-645PCW / SCW Only
		B: $\pm 50 \times 10^{-6}$ C: $\pm 100 \times 10^{-6}$		—	-20 °C to +70 °C *1
		—		—	-40 °C to +85 °C : SG-645PCW / SCW Only
Current consumption	I_{CC}	45 mA Max.		28 mA Max.	No load condition(Max. frequency range)
Disable current	I_{dis}	30 mA Max.		16 mA Max.	OE=GND (PTW,PHW,PCW)
Stand-by current	I_{std}	50 μ A Max.		—	\overline{ST} =GND (STW,SHW,SCW)
Symmetry	SYM	—		40 % to 60 %	50 % V_{CC} level, L_CMOS=Max.
		40 % to 60 %		—	1.4 V level, L_CMOS=Max.
Output voltage	V_{OH}	V _{CC} -0.4 V Min.			I_{OH} =-16 mA (PTW , STW , PHW , SHW)
	V_{OL}	0.4 V Max.			-8 mA (PCW , SCW)
Output load condition (TTL)	L_{TTL}	5 TTL Max.	—	—	$f_0 \leq 90$ MHz, Max. Supply voltage.
Output load condition (CMOS)	L_{CMOS}	15 pF Max.			Max.frequency, Max.Supply voltage.
Input voltage	V_{IH}	2.0 V Min.		70 % V_{CC} Min.	OE Terminal or \overline{ST} Terminal
	V_{IL}	0.8 V Max.		20 % V_{CC} Max.	
Rise time / Fall time	t_r / t_f	—		4 ns Max.	20 % V_{CC} to 80 % V_{CC} level, L_CMOS \leq Max.
		4 ns Max.	—	—	0.4 V to 2.4 V level
Start-up time	t_{str}	10 ms Max.			Time at minimum supply voltage to be 0 s
Frequency aging	f_{aging}	$\pm 5 \times 10^{-6}$ / year Max.			+25 °C, V_{CC} =5.0 V / 3.3 V, First year

*1 SG-636 series "C" tolerance : 40 MHz < f_0 \leq 135 MHz

External dimensions

(Unit:mm)

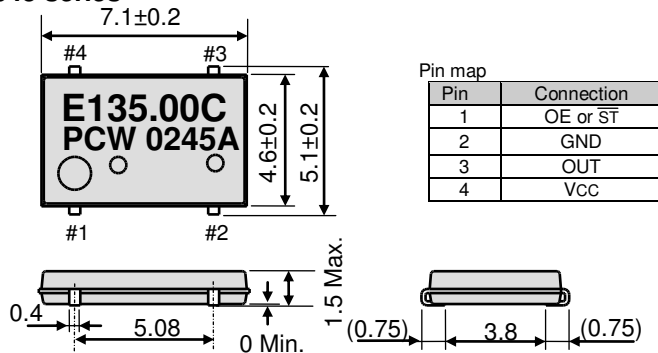
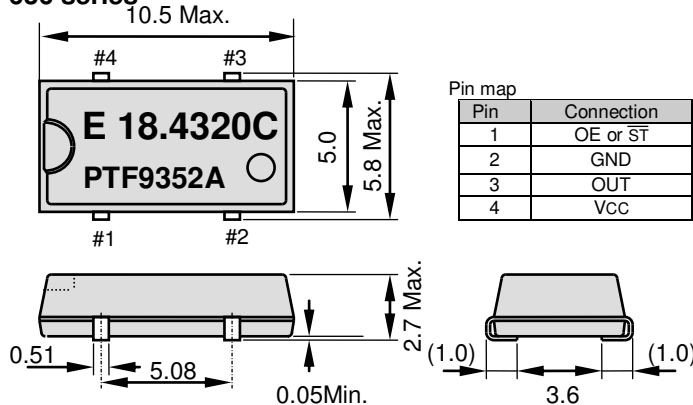
SG-645 series

SG-636 series

Metal may be exposed on the top or bottom of this product. This will not affect any quality, reliability or electrical spec.

Note.

OE pin (PTF,PCE,PDE,PTW,PHW,PCW,PTG,PHG,PCG)

OE pin = "H" or "open" : Specified frequency output.

OE pin = "L" : Output is high impedance.

\overline{ST} pin (STW, SHW, SCW,SCG)

\overline{ST} pin = "H" or "open" : Specified frequency output.

\overline{ST} pin = "L" : Output is low level (weak pull - down), oscillation stops.

\overline{ST} pin (SCE)

\overline{ST} pin = "H" or "open" : Specified frequency output.

\overline{ST} pin = "L" : Output is low level , oscillation stops.

Footprint (Recommended)

(Unit:mm)

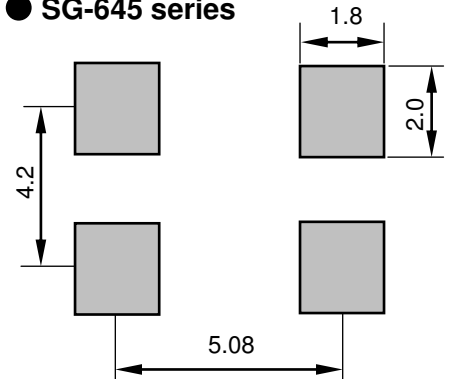
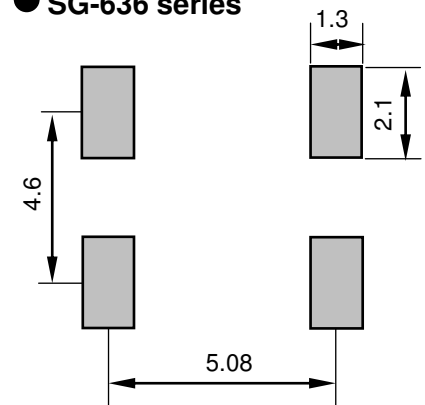
SG-645 series

SG-636 series

To maintain stable operation, provide a 0.01 μ F to 0.1 μ F by-pass capacitor at a location as near as possible to the power source terminal of the crystal product (between V_{CC} - GND).