

For Automotive
SERIAL INTERFACE REAL TIME CLOCK MODULE



Product Number (Please contact us)
RA-4565SA : Q41A46552xxxx00

RA - 4565 SA

- Built in frequency adjusted 32.768 kHz crystal unit.
- Interface Type : 4-wire serial interface
- Wide operating voltage range : 1.6 V to 5.5 V
- Wide Timekeeper voltage range : 1.5 V to 5.5 V
T_a = -40 °C to +125 °C
- Extended operating temperature range: -40 °C to +125 °C
- 32.768 kHz frequency output function : Open drain output with Control Pin
- 32.768 kHz Clock/calendar function, auto leap year correction function, alarm interrupt function, etc.
- Conforms to AEC-Q200



Actual size



Block diagram

Overview

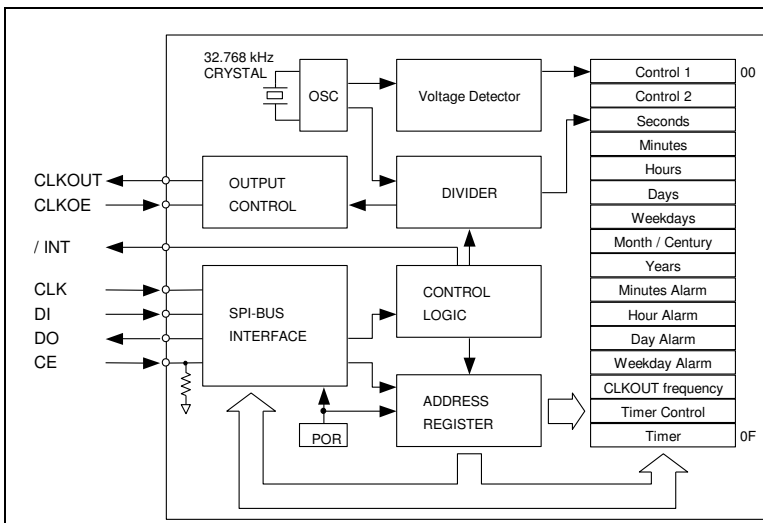

- **Wide operating temperature range**
 - -40 °C to +125 °C
- **Clacking-status detection function**
 - It can judge the validity of data after backup operation return by a status of VL-bit.
- **32.768 kHz frequency output function**
 - CLKOUT pin output (Open Drain output)
 - Output frequency can be selected as 32.768 kHz, 1024 Hz, 32 Hz, or 1 Hz.
- **The various interrupt function**
 - Timer function can be set up between 1/4096 second and 255 minutes.
 - Alarm function can be set to day of week, day, hour, or minute.

Pin Function

Terminal connection / External dimensions

(Unit:mm)

Terminal	Directions	Functions
CE	Input	Chip enabled input.
CLK	Input	Serial clock input.
DI	Input	Data input.
DO	Output	Data output.
CLKOUT	Output	The CLKOUT pin is a clock output (open drain output) pin with control output. (Output frequency can be selected as 32.768 kHz, 1024 Hz, 32 Hz, or 1 Hz.)
CLKOE	Input	The CLKOE pin is an input pin used to control the output mode of the CLKOUT output pin. During the initial power-on (when power is applied from 0 V), if the CLKOE input pin is at high level (= H), the power-on reset function selects 32.768 kHz as the frequency.
/INT	Output	Interrupts output by Alarm and Timer events. (Open drain output)
VDD	-	VDD
GND	-	GND

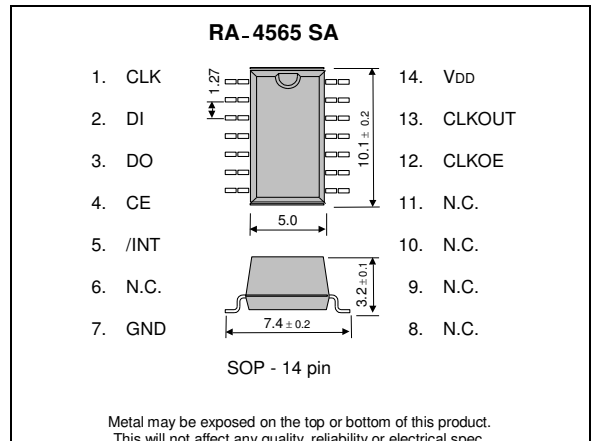

Specifications (characteristics)

* Refer to application manual for details.

Recommended Operating Conditions

Item	Symbol	Conditions	Min.	Typ.	Max.	unit
Operating voltage	VDD	-	1.6	3.0	5.5	V
Timekeeper voltage	VCLK	-	1.5	3.0	5.5	V
Operating temperature	TOPR	-	-40	+25	+125	°C

Frequency characteristics

Item	Symbol	Conditions	Rating	unit
Frequency stability	$\Delta f / f$	T _a = +25 °C VDD = 3.0 V	5 ± 23 ^{*1}	× 10 ⁻⁶
Oscillation start up time	tSTA	T _a = +25 °C VDD = 1.6 V	1.5 Max.	s
		T _a = -40 °C to +125 °C VDD = 3.0 V	3.0 Max.	s

*1) Equivalent to 1 minutes of monthly deviation.

Current consumption under backup mode.

Item	Symbol	Conditions	Min.	Typ.	Max.	unit
Standby current.	IBK	fsCL = 0 Hz CLKOE = "L"	+125 °C	1.0	2.0	μA
		VDD = 5 V				
		fsCL = 0 Hz CLKOE = "L"	+125 °C	0.8	1.6	
		VDD = 3 V				