

Simple Function  
SERIAL-INTERFACE REAL TIME CLOCK MODULE

RTC - 4543 SA / SB

- Built in frequency adjusted 32.768 kHz crystal unit.
- Interface type : 3-wire serial interface
- Operating voltage range : 2.5 V to 5.5 V
- Wide Timekeeper voltage range: 1.4 V to 5.5 V
- 32.768 kHz frequency output function: C-MOS output With Control Pin
- The various functions include full calendar, timer, and low voltage detection.



Product Number (Please contact us)  
RTC-4543SA : Q41454352000200  
RTC-4543SB : Q41454361000200



Actual size

RTC-4543SA



RTC-4543SB



Block diagram

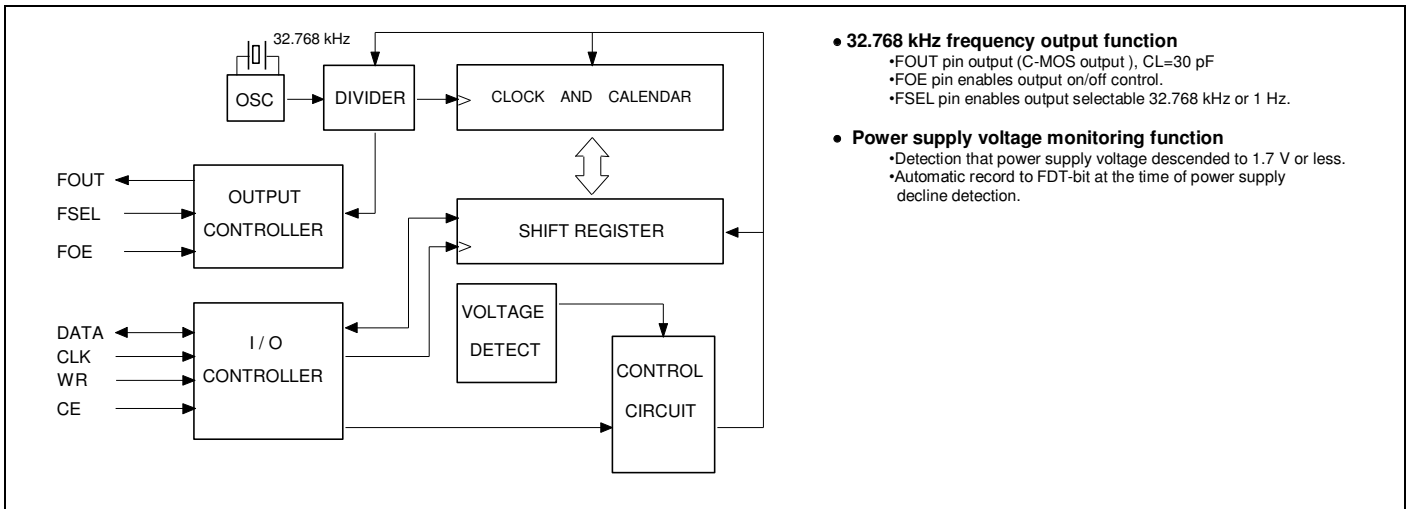

- **32.768 kHz frequency output function**
  - FOUT pin output (C-MOS output), CL=30 pF
  - FOE pin enables output on/off control.
  - FSEL pin enables output selectable 32.768 kHz or 1 Hz.
- **Power supply voltage monitoring function**
  - Detection that power supply voltage descended to 1.7 V or less.
  - Automatic record to FDT-bit at the time of power supply decline detection.

Pin Function

Signal Name	Input / Output	Function
CE	Input	The chip enabled input pin. At the HIGH level, access becomes possible.
CLK	Input	The shift clock input pin for serial data transfer.
WR	Input	DATA pin input / output switching pin.
DATA	Bi-directional	The data input / output pin for serial data transfer.
FOUT	Output	32.768 kHz or 1Hz clock output pin (C-MOS output). High impedance at output off.
FOE	Input	The input pin for the FOUT output control.
FSEL	Input	Select the frequency that is output from the FOUT pin.
VDD	—	Connected to a positive power supply.
GND	—	Connected to a ground.

Terminal connection / External dimensions

(Unit:mm)

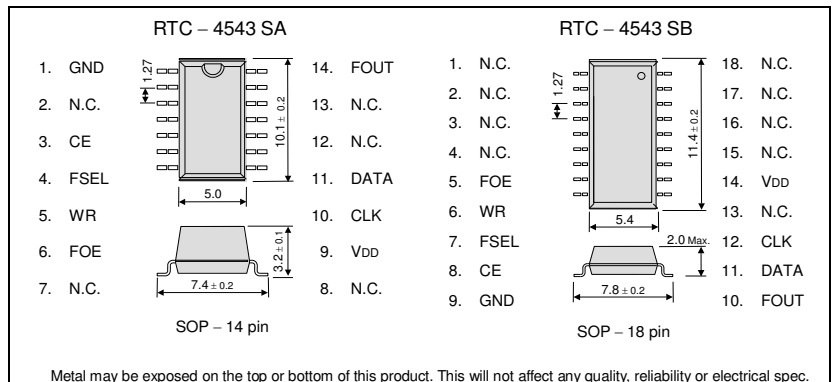

Specifications (characteristics)

\* Refer to application Manual for details.

Recommended Operating Conditions

Item	Symbol	Condition	Min.	Typ.	Max.	Unit
Power voltage	VDD	—	2.5	5.0	5.5	V
Clock voltage	VCLK	—	1.4	5.0	5.5	V
Operating temperature	TOPR	—	-40	+25	+85	°C

Frequency characteristics

Item	Symbol	Condition	Rating	Unit
Frequency tolerance	$\Delta f / f$	T <sub>a</sub> = +25 °C VDD = 5.0 V	5 ± 23 *	× 10 <sup>-6</sup>
Oscillation start-up time	t <sub>STA</sub>	T <sub>a</sub> = +25 °C VDD = 2.5 V	3 Max.	s

\* Please ask for tighter tolerance.(Equivalent to 1 minute of monthly deviation )

Current consumption characteristics

T<sub>a</sub> = -40 °C to +85 °C

Item	Symbol	Condition	Min.	Typ.	Max.	Unit
Current Consumption	I <sub>BK</sub>	CE = GND FOE = GND FOUT ;output OFF (Hi-z)	VDD = 5 V	1.5	3.0	μA
			VDD = 3 V	1.0	2.0	
			VDD = 2 V	0.5	1.0	

Supply Voltage Detection Characteristic

T<sub>a</sub> = -40 °C to +85 °C

Item	Symbol	Condition	Min.	Typ.	Max.	Unit
Power supply detection voltage	VDT	VDD pin	1.4	1.7	2.0	V