

SERIAL-INTERFACE REAL TIME CLOCK MODULE

RTC - 4574 SA / JE / NB

- Built in frequency adjusted 32.768 kHz crystal unit.
- Interface Type : 3-wire serial interface
- Operating voltage range : 1.6 V to 5.5 V
- Wide Timekeeper voltage range : 1.6 V to 5.5 V
- Low backup current : 0.5 μ A / 3 V (Typ.)
- 32.768 kHz frequency output function : C-MOS output With Control Pin
- The various functions include full calendar, alarm, timer.



Product Number (Please contact us)
 RTC-4574SA : Q41457452000200
 RTC-4574JE : Q41457471000100
 RTC-4574NB : Q41457492000100



Actual size

RTC-4574SA

RTC-4574JE

RTC-4574NB



Block diagram

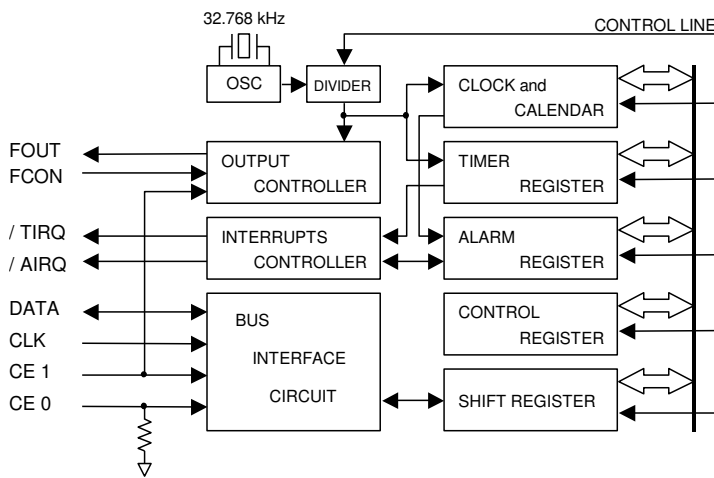

Overview

- **32.768 kHz frequency output function**
 - FOUT pin output (C-MOS output), CL=30 pF
 - Output frequency selectable from 1/30 Hz to 32.768 kHz (32 Values)
- **Timer function**
 - Timer function can be set up between 1/4096 second and 255 minutes.
 - It is recorded automatically to TF-bit at the time of event occurrence, and it's possible to output with /TIRQ pin output (open-drain output).
 - Selectable one time mode or repeat mode.
- **Alarm function**
 - Alarm function can be set to any combination of day of week, hour, or minute.
 - It is recorded automatically to AF-bit at the time of event occurrence, and it's possible to output with /AIRQ pin output (open-drain output).

* Functions are compatible with RX - 4574 LC.

Terminal connection / External dimensions

(Unit:mm)

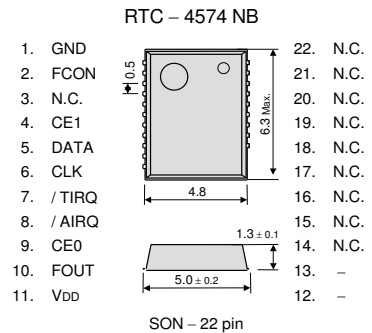
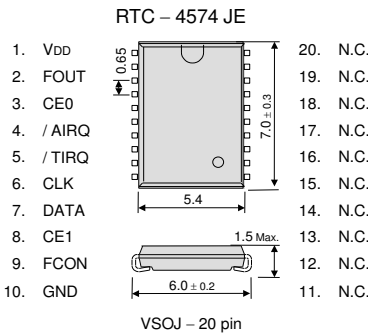
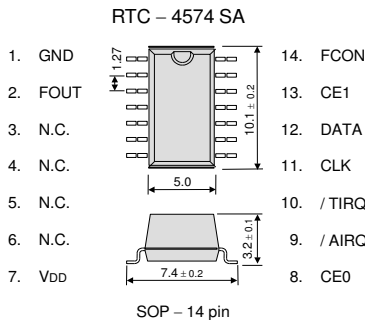

Metal may be exposed on the top or bottom of this product. This will not affect any quality, reliability or electrical spec.

Specifications (characteristics)

* Refer to application manual for details.

Recommended Operating Conditions

Item	Symbol	Condition	Min.	Typ.	Max.	Unit
Power voltage	V _{DD}	—	1.6	3.0	5.5	V
Clock voltage	V _{CLK}	—	1.6	3.0	5.5	V
Operating temperature	T _{OPR}	—	-40	+25	+85	°C

Frequency characteristics

Item	Symbol	Condition	Rating	Unit
Frequency tolerance	$\Delta f / f$	T _a = +25 °C V _{DD} = 3.0 V	5 ± 23 *	× 10 ⁻⁶
Oscillation start-up time	t _{STA}	T _a = +25 °C V _{DD} = 1.6 V	3 Max.	s

* Please ask for tighter tolerance. (Equivalent to 1 minute of monthly deviation)

Current consumption characteristics

T_a = -40 °C to +85 °C

Item	Symbol	Condition	Min.	Typ.	Max.	Unit
Current Consumption	I _{BK}	CE ₀ , CE ₁ = GND	V _{DD} = 5 V	1.0	2.0	μ A
		FOUT ; output OFF (Hi - z)	V _{DD} = 3 V	0.5	1.0	
	I _{32k}	CE ₀ = GND CE ₁ = V _{DD}	V _{DD} = 5 V	8.0	20.0	μ A
		FOUT ; 32.768 kHz output ON CL = 30 pF	V _{DD} = 3 V	5.0	12.0	