

High-Stability Frequency SERIAL-INTERFACE REAL TIME CLOCK MODULE

RX-4045 SA / NB

- Built-in 32.768 kHz crystal unit : Frequency adjusted for high accuracy. ($\pm 5 \times 10^{-6} / T_a = +25^\circ\text{C}$)
- Interface Type : 4-wire serial interface
- Operating voltage range : 1.7 V to 5.5 V
- Wide Timekeeper voltage range : 1.15 V to 5.5 V
- Various detection Functions : Oscillation stop detection function etc.
- Low backup current : 0.48 μA / 3 V (Typ.)
- 32.768 kHz clock frequency output : N-ch open drain output
- Function of time and calendar, the various detection function, and interrupt function etc.



Product Number (Please contact us)
 RX-4045SA : Q41404552xxxx00
 RX-4045NB : Q41404592xxxx00

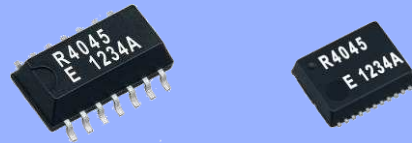

Actual size

RX-4045SA

RX-4045NB



Block diagram

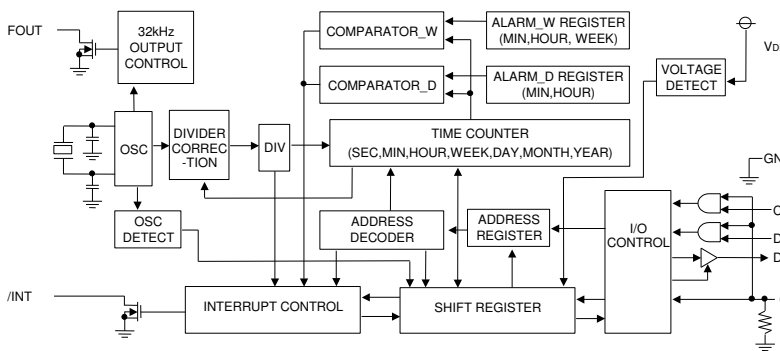

Overview

- **Features built-in 32.768 kHz crystal unit**
 - Frequency adjusted for high accuracy ($\pm 5 \times 10^{-6} / T_a = +25^\circ\text{C}$) (Equivalent to 13 seconds of monthly deviation)
- **The various detection Function**
 - Power supply voltage monitoring function (with selectable detection threshold)
 - Stop detection function
 - Power-on reset detection function
- **Equipped with alarm and timer**
 - Timer function produces a periodic interruption signal. As for the Alarm function an optional combination is produced. (Date of the week, time, minute)

Pin function

Signal Name	Input / Output	Function
CE	Input	The chip enabled input pin. (built-in pull-down resistance) At the "H" level, access becomes possible.
CLK	Input	The shift clock input pin for serial data transfer.
DI	Input	The data input pin for serial data transfer.
DO	Output	The data output pin for serial data transfer.
FOUT	Output	32.768 kHz clock output pin with the output control function (N-ch open drain) High impedance at the time of output off.
/INT	Output	Interrupt output (N-ch open drain)
TEST	—	* Used by the manufacturer for testing. (Do not connect externally.)
VDD	—	Connected to a positive power supply.
GND	—	Connected to a ground.

Terminal connection / External dimensions

(Unit:mm)

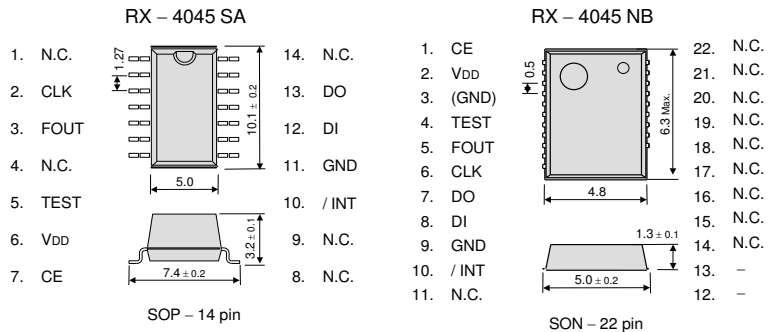

Metal may be exposed on the top or bottom of this product. This will not affect any quality, reliability or electrical spec.

Specifications (characteristics)

* Refer to application manual for details.

Recommended Operating Conditions

Item	Symbol	Condition	Min.	Typ.	Max.	Unit
Power voltage	VDD	—	1.7	3.0	5.5	V
Clock voltage	VCLK	—	1.15	3.0	5.5	V
Operating temperature	TOPR	—	-40	+25	+85	°C

Frequency characteristics

Item	Symbol	Condition	Rating	Unit
Frequency tolerance	$\Delta f / f$	$T_a = +25^\circ\text{C}$ $V_{DD} = 3.0\text{ V}$	AA: 5 ± 5 ^{*1)} AC: 0 ± 5 ^{*2)}	$\times 10^{-6}$
Oscillation start-up time	tSTA	$T_a = +25^\circ\text{C}$ $V_{DD} = 2.0\text{ V}$	1 Max.	s
Frequency / voltage characteristics	f / V	$T_a = +25^\circ\text{C}$ $V_{DD} = 2.0\text{ V to } 5.5\text{ V}$	± 1 Max.	$\times 10^{-6}$

*1) *2) Equivalent to 13 seconds of monthly deviation (excluding offset.)

Current consumption characteristics

$T_a = -40^\circ\text{C to } +85^\circ\text{C}$

Item	Symbol	Condition	Min.	Typ.	Max.	Unit
Current Consumption	I _{bk}	CE = GND FOUT ; output OFF (Hi-z)	V _{DD} = 5 V	0.60	1.80	μA
			V _{DD} = 3 V	0.48	1.20	
	I _{32k}	CE = GND FOUT ; 32.768 kHz output ON	V _{DD} = 3 V	0.65	2.00	μA

Power supply detection voltage

$T_a = -30^\circ\text{C to } +70^\circ\text{C}$

Item	Symbol	Condition	Min.	Typ.	Max.	Unit
High-voltage mode	V _{DETH}	VDD pin	1.90	2.10	2.30	V
Low-voltage mode	V _{DETL}	VDD pin	1.15	1.30	1.45	V